

PF91025



1/5 HP Submersible Thermoplastic Utility Pump

Product Features

- Tough thermoplastic construction
- 1-1/4" NPT discharge
- Clog resistant impeller
- Sleek design allows pump to fit in 6" opening
- 3/4" garden hose adapter included
- 10' power supply cord
- Built-in thermal overload protection for safety
- Permanent split capacitor continuous duty motor



PF91025

Motor Performance

- 1/5 HP 120 Volt AC (3.6 amps)

Performance Chart						
Lift	0'	5'	10'	15'	20'	25'
GPM	26	21	14	10	7	1
GPH	1560	1260	840	600	420	60

Product Specifications

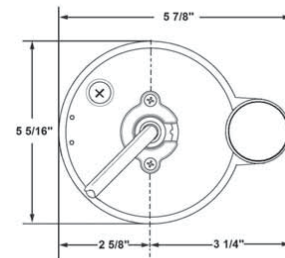
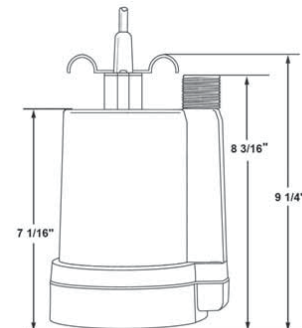

* All measurements are nominal. Please verify before actual installation.

Warranty and Codes

This product comes complete with installation, operating, care and maintenance instructions. This PROFLO sump pump carries a 3 year warranty when installed in residential applications. See owners manual for warranty details.

This PROFLO sump pump carries a 5 year limited warranty. In an effort to continually improve our products, we will make design changes from time to time. We reserve the right to ship newly designed product to fill any order unless it is agreed in writing to do otherwise.

Distributed Exclusively by Ferguson and Wolseley Canada
© 2018 Ferguson Enterprises, Inc.



342876 03/18