

Assembly Instructions

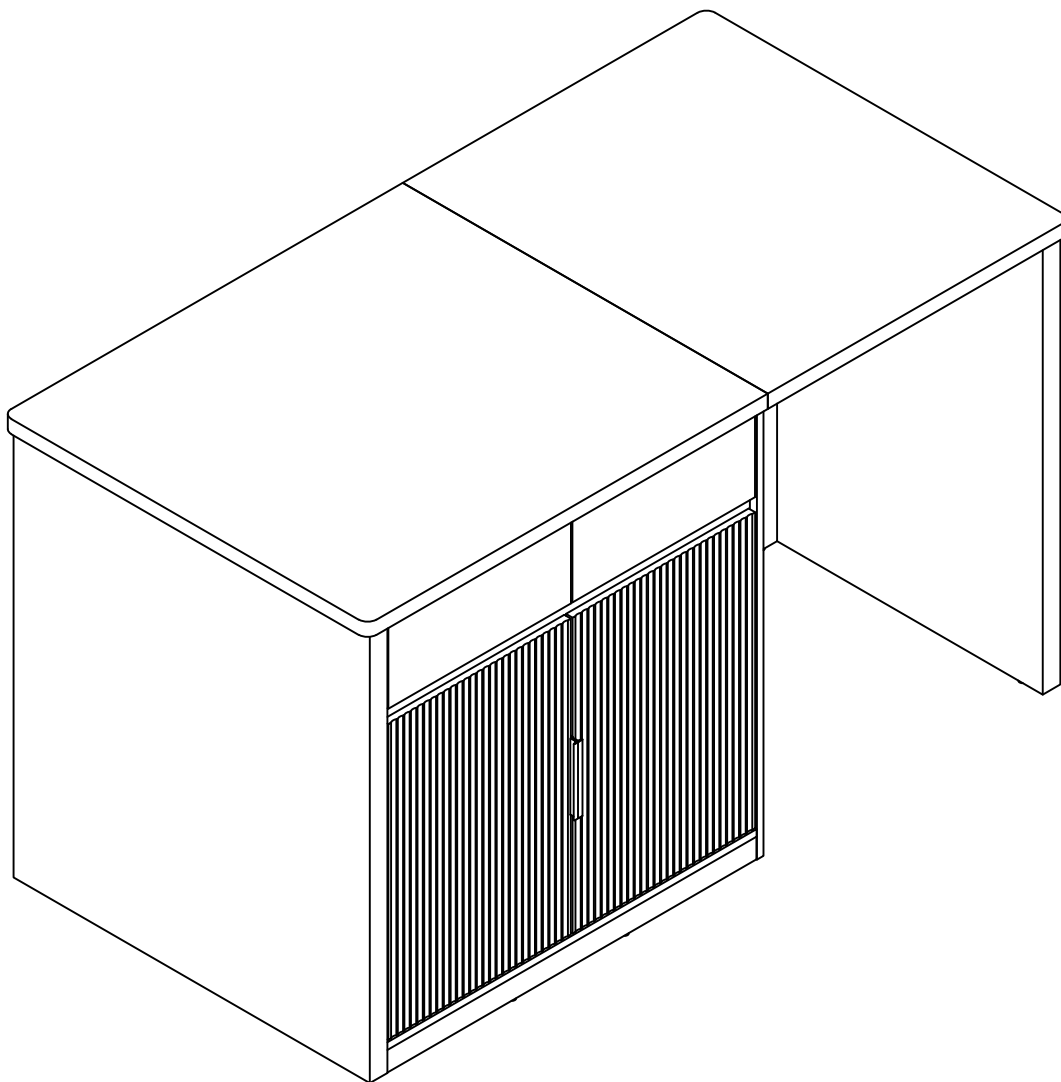

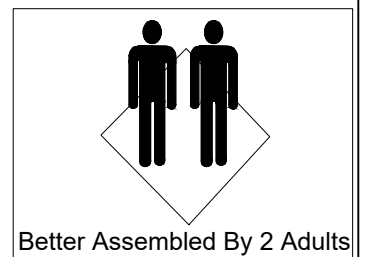





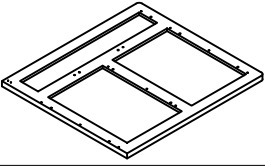
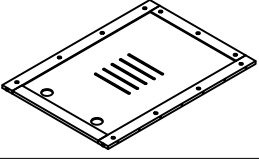
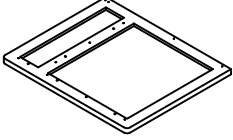
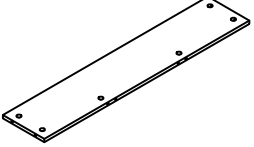
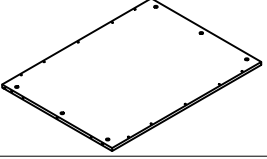
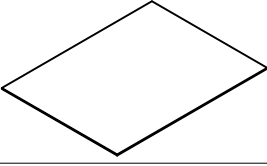
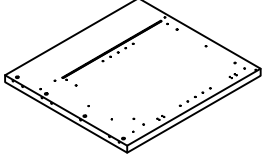
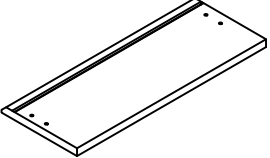
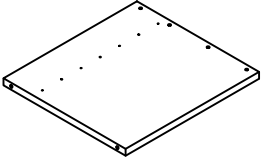
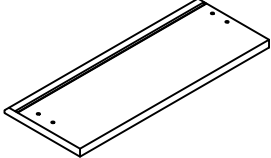
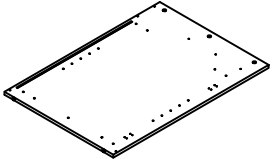
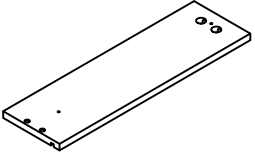
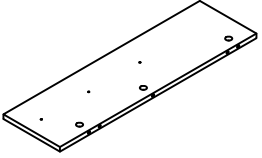
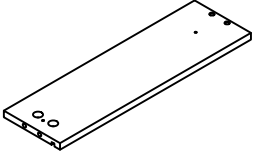
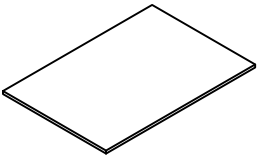
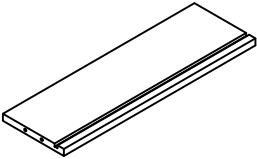
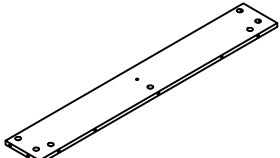
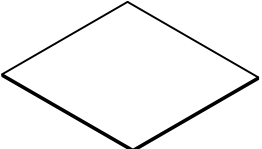
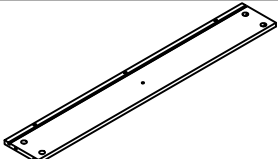
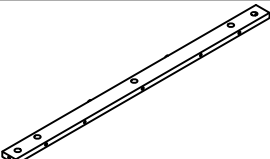
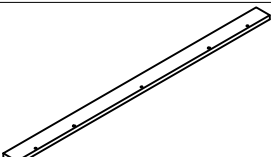
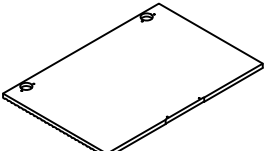



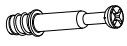



We come with the necessary tools for assembly but for faster assembly, a power drill is recommended.

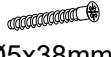
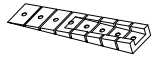
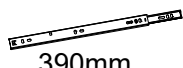

Parts List

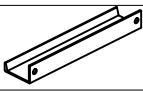
ITEM	PART	QTY	ITEM	PART	QTY
①		1PC	⑫		1PC
②		1PC	⑬		1PC
③		1PC	⑭		1PC
④		1PC	⑮		1PC
⑤		1PC	⑯		1PC
⑥		1PC	⑰		2PCS
⑦		1PC	⑱		2PCS
⑧		1PC	⑲		2PCS
⑨		1PC	⑳		2PCS
⑩		1PC	㉑		2PCS
⑪		1PC	㉒		2PCS

Hardware List

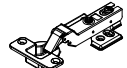
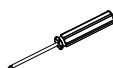
ITEM	PART	QTY	ITEM	PART	QTY
A	 Ø6x35mm	66+5 PCS	J		2 PCS
B	 Ø15x10mm	66+5 PCS	K		4+1 PCS
C	 Ø6x30mm	34+3 PCS	L	 Ø8xØ4x14mm	6+1 PCS
D	 Ø5x38mm	13+1 PCS	M		6 PCS
E	 390mm	4 PCS	N		12+1 PCS
F	 Ø6xØ3x12mm	32+3 PCS	N	 Ø6xØ3x16mm	12+1 PCS
G		2 PCS	O		1 PC
H	 Ø7xØ3.5x14mm	24+2 PCS	P	 Ø20mm	36+4 PCS
I		4 PCS			1 PC

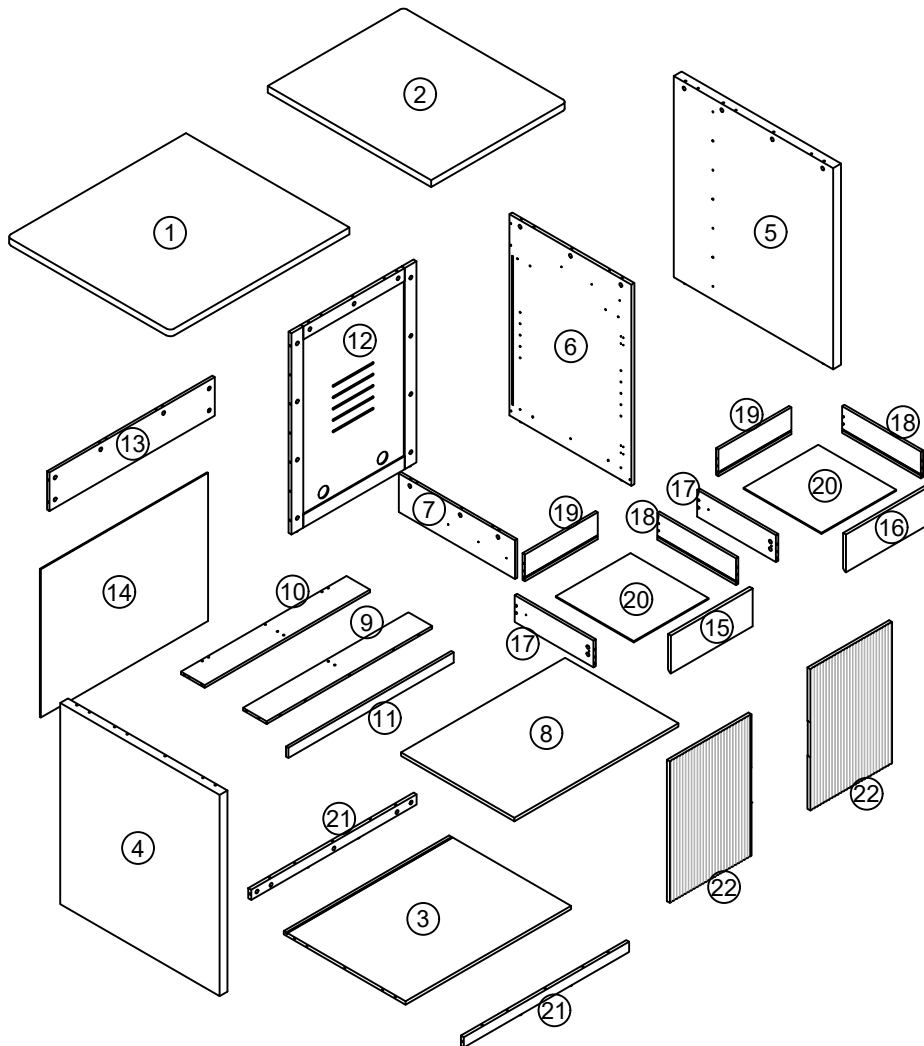

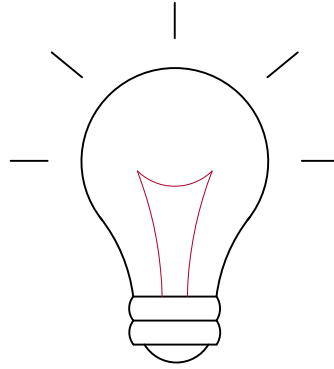

friendly reminder

To avoid errors and confusion during the installation of accessories, use the type and quantity of hardware accessories according to the installation procedure described in the instructions. First, unroll the accessories bag and lay out the hardware accessories, cut holes in the side, and take out the hardware accessories

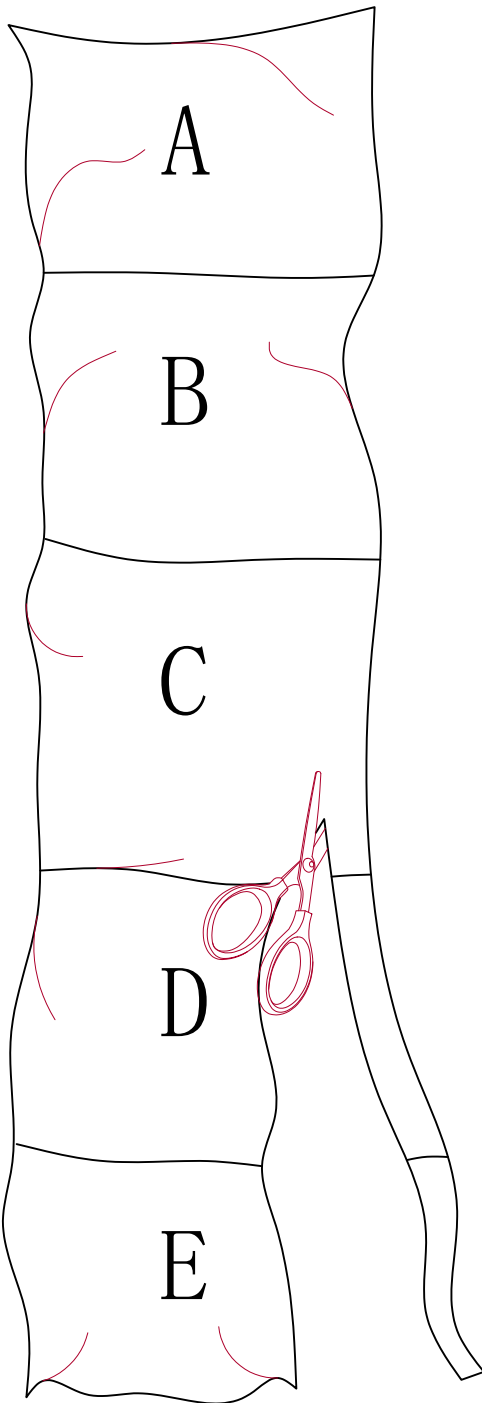

01

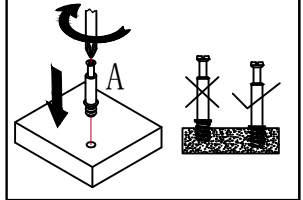
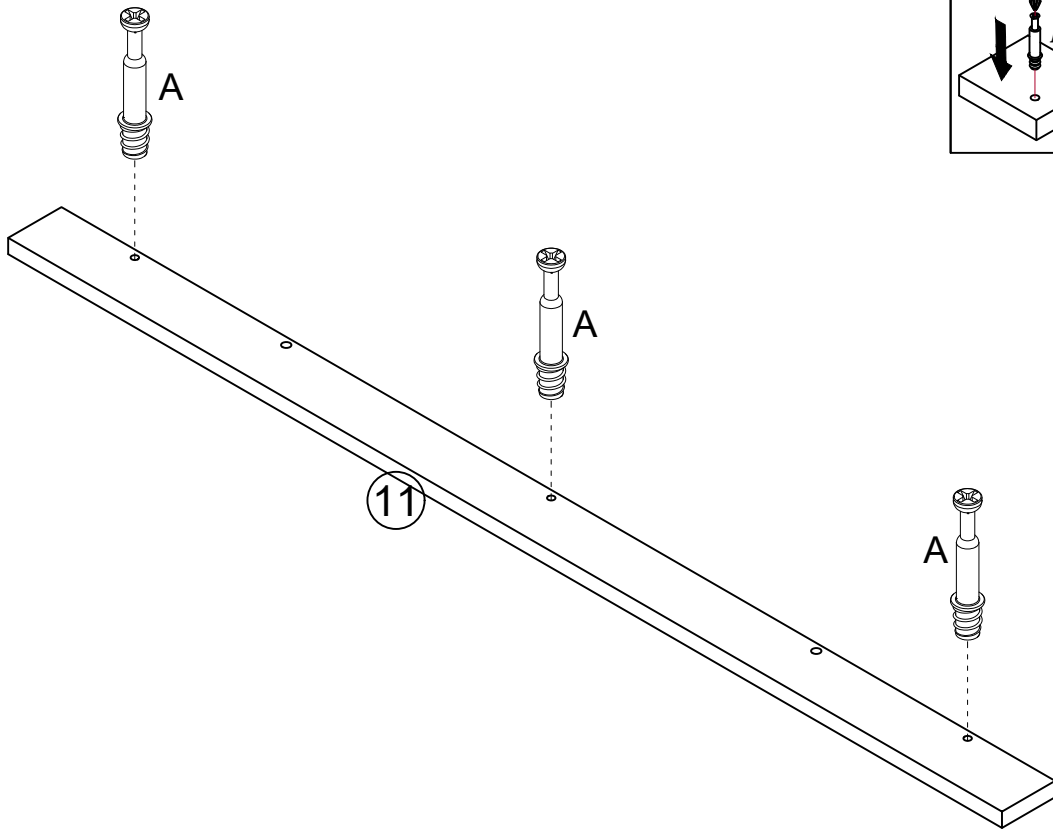

Install Cam Bolt A*3 on Part #11 as shown.

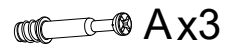

02

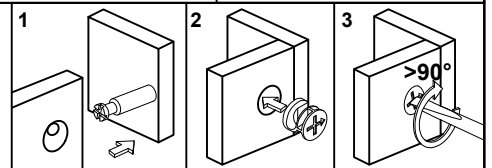
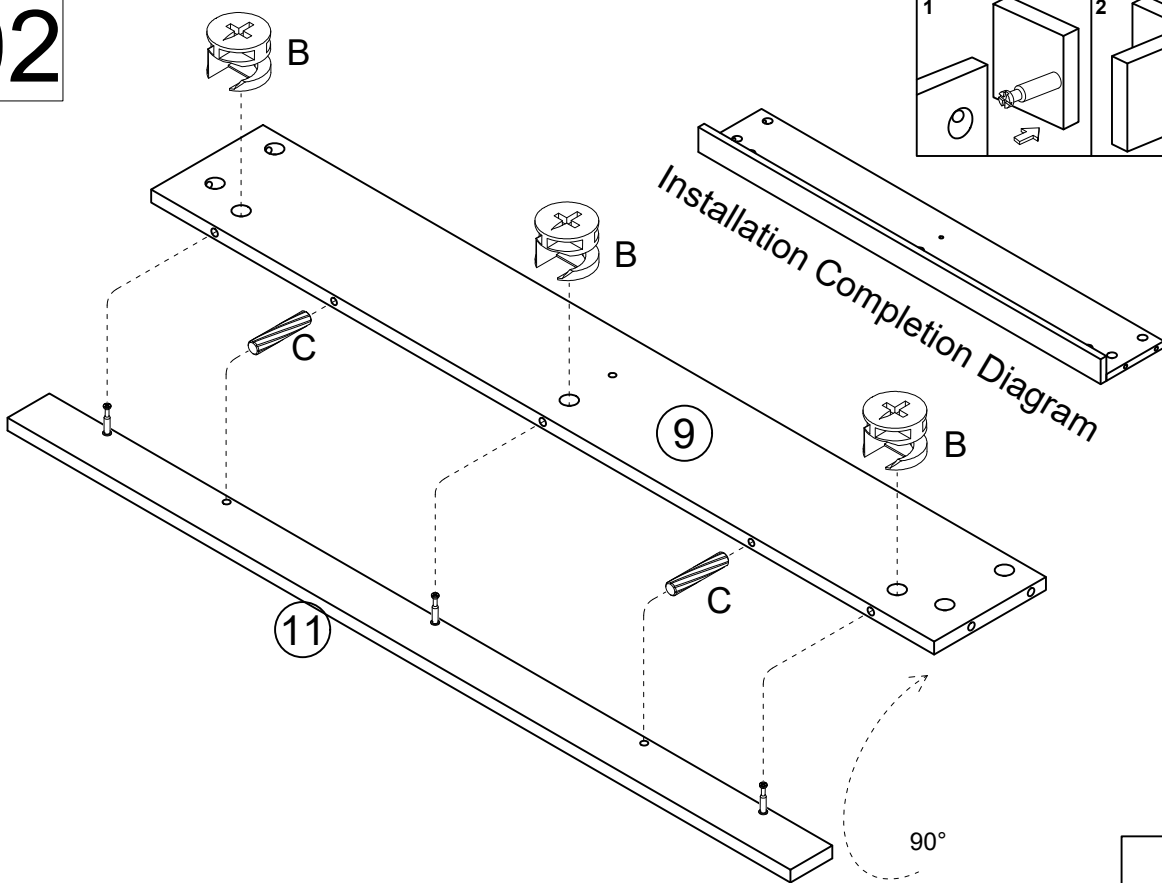

Attach Part #11 to Part #9 with Dowels C*2 and Nuts B*3 as shown. Then turn Nuts B*3 to secure position.



Bx3

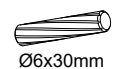

Ø6x30mm

Cx2

03

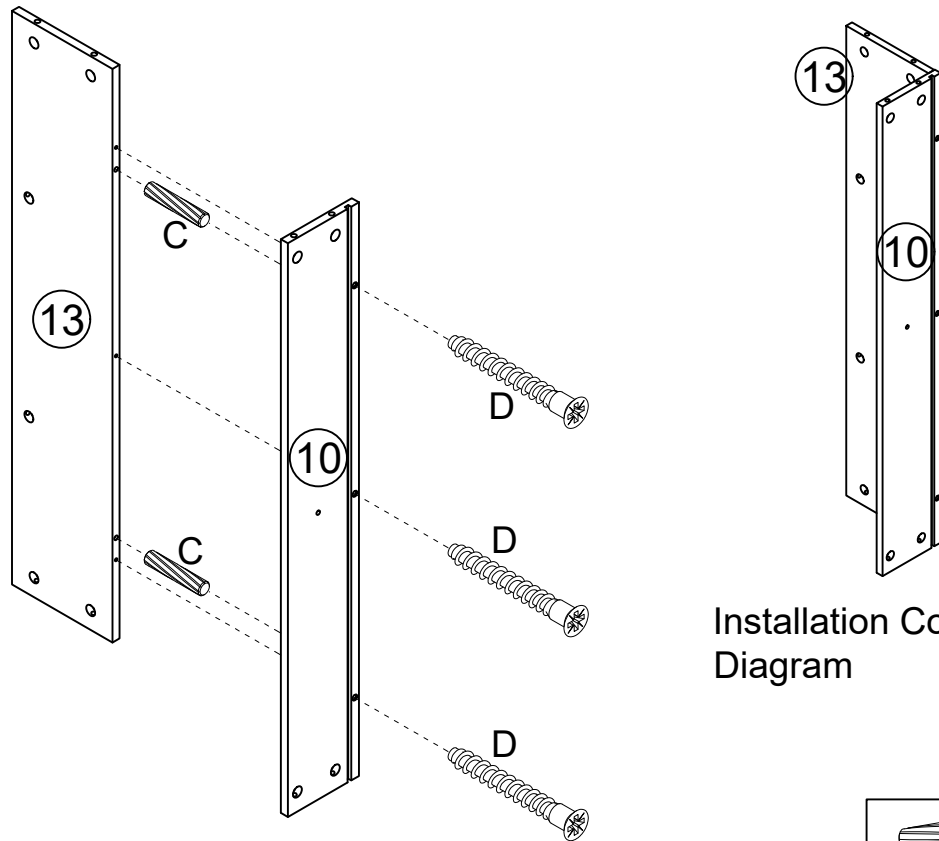

Installation Completion Diagram

Attach Part #10 to Part #13 with Dowels C*2 and Screws D*3 as shown.

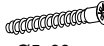
 Ø6x30mm	Cx2
 Ø5x38mm	Dx3

04

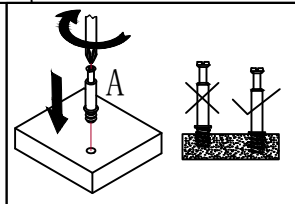
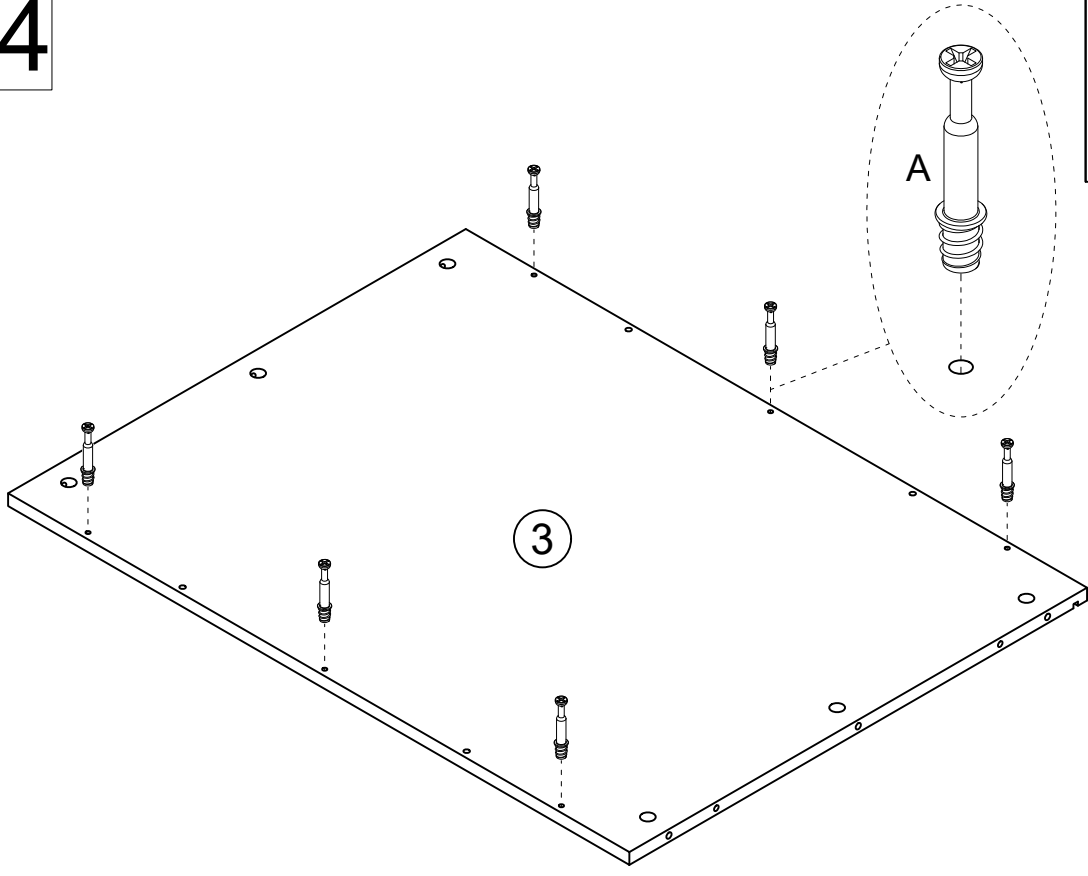

Install Cam Bolt A*6 on Part #3 as shown.

	Ax6
---	-----

05

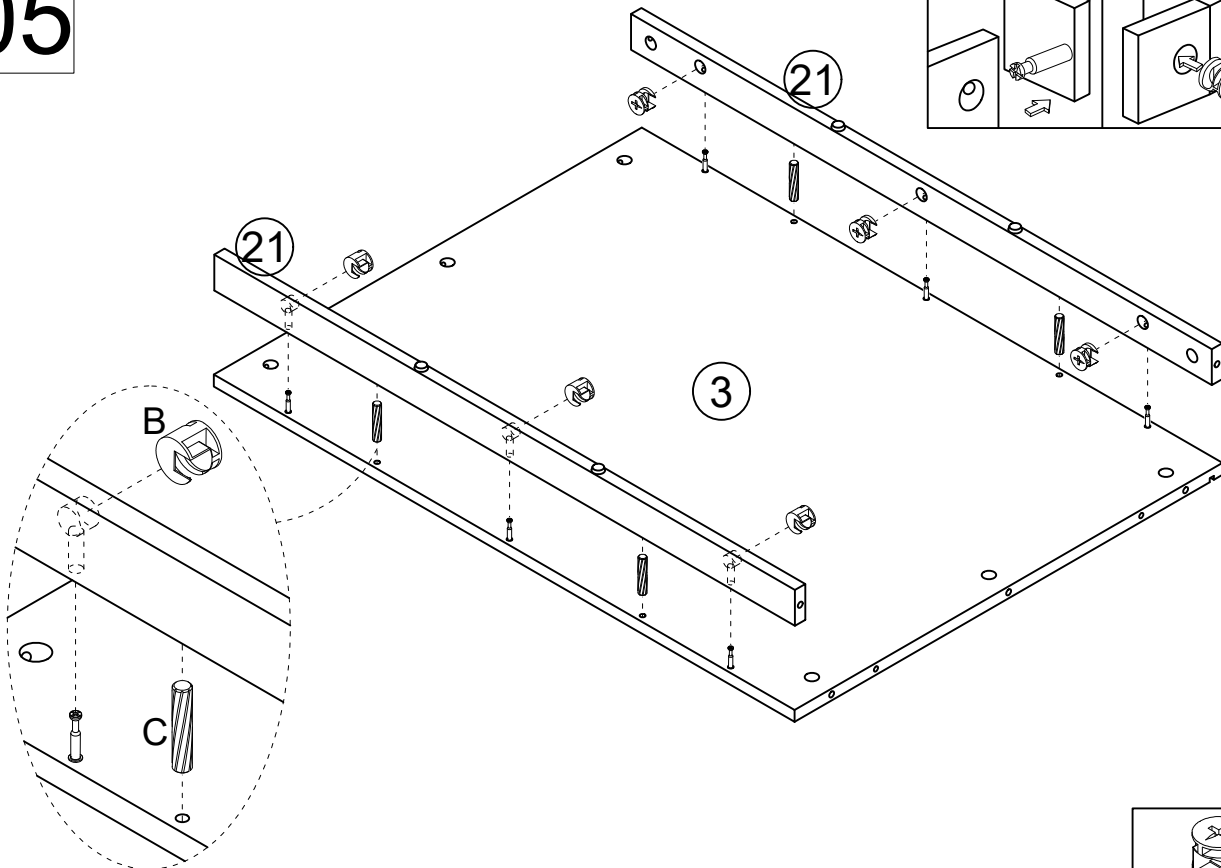
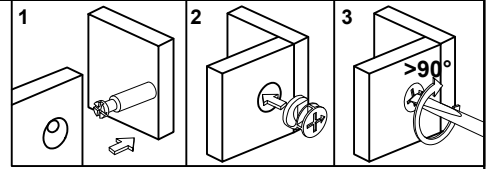

Attach Part #21*2 to Part #3 with Dowels C*4 and Nuts B*6 as shown. Then turn Nuts B*6 to secure position.

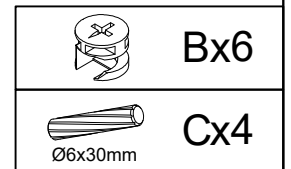

06

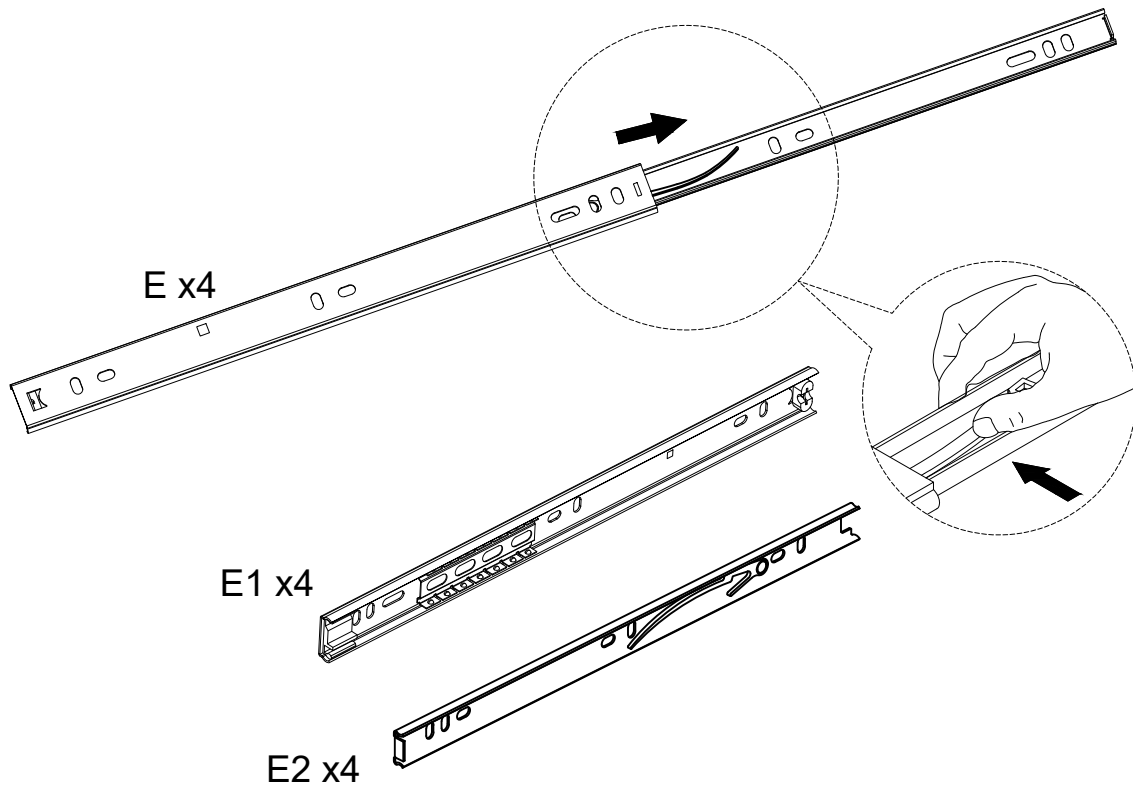

Extend slides E*4, then push the release lever upward to detach the outer rails E1*4 and the inner rails E2*4 as shown.

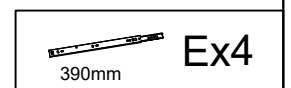

07

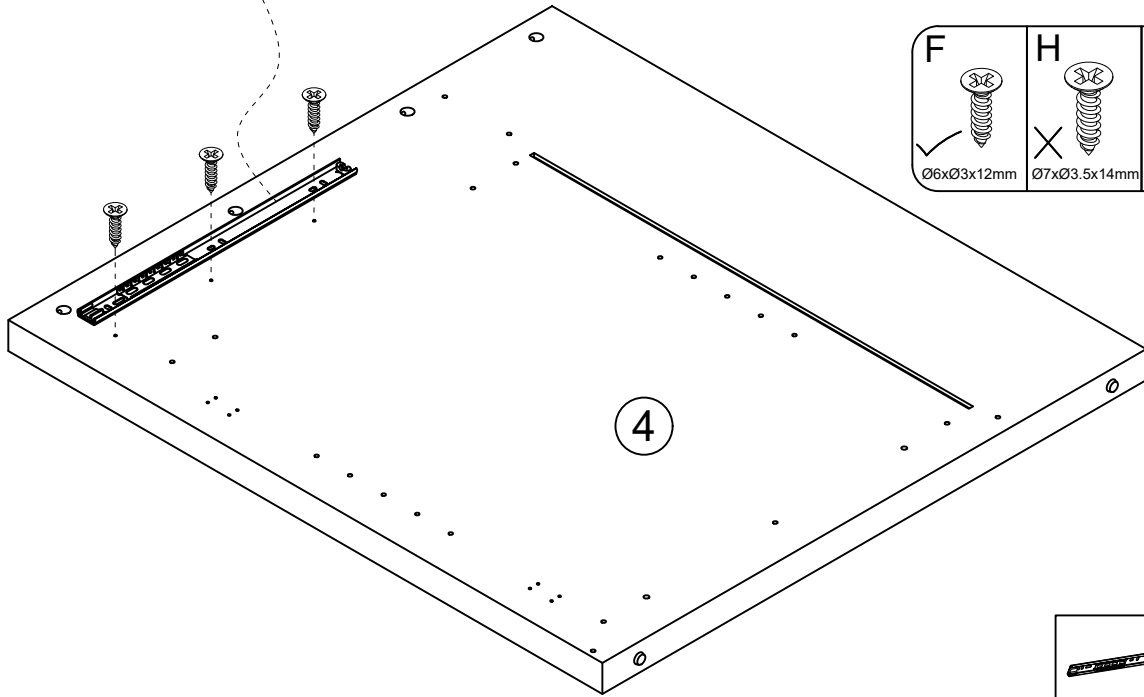
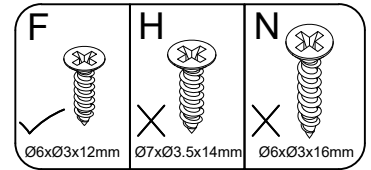
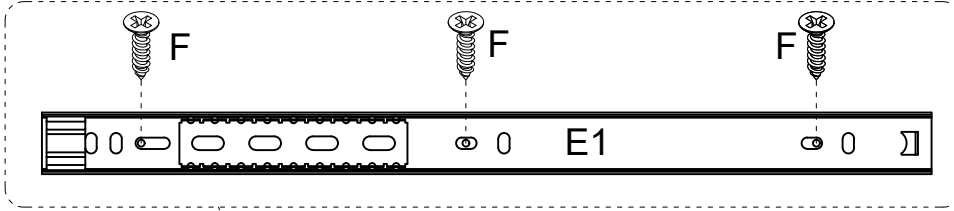

Install the outer rail E1 on Part #4 with Screws F*3 as shown.

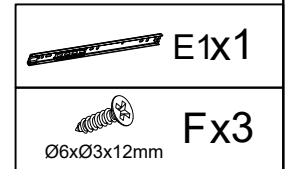

08

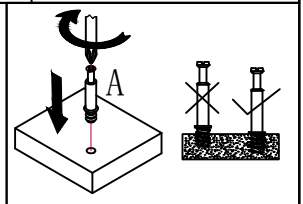
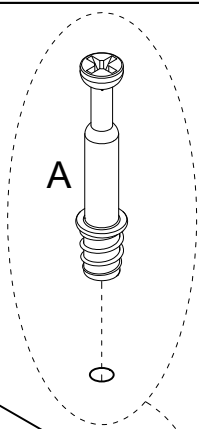
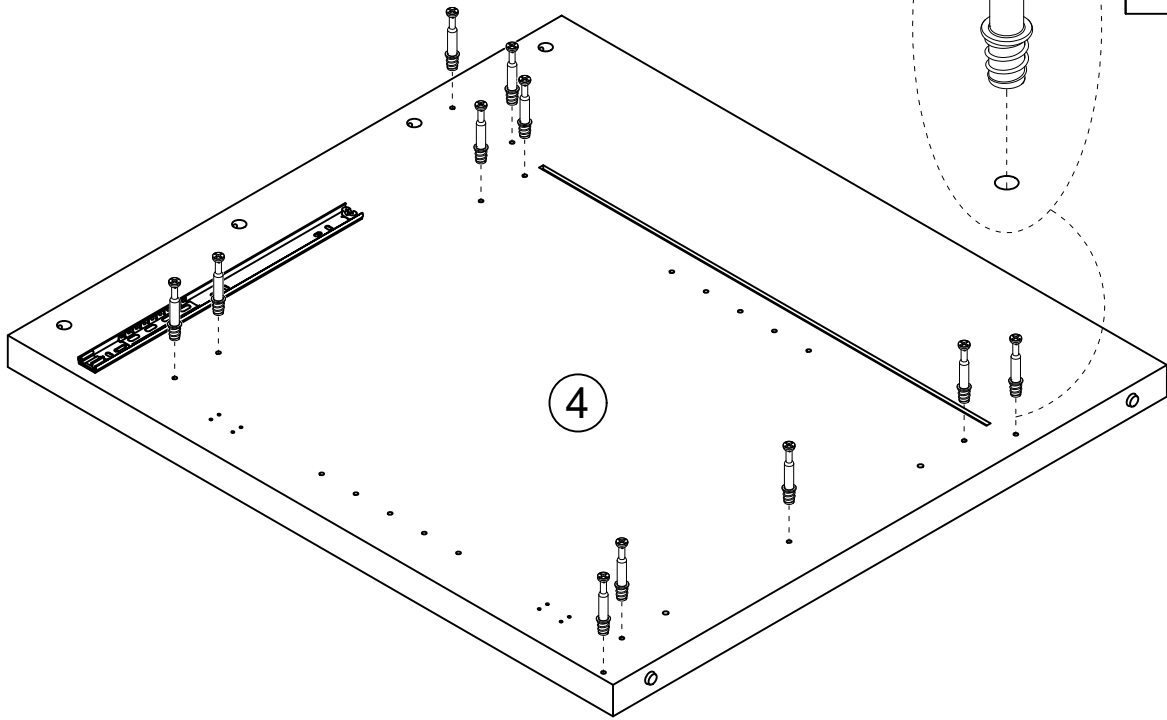

Install Cam Bolt A*11 on Part #4 as shown.

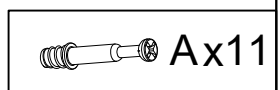

09

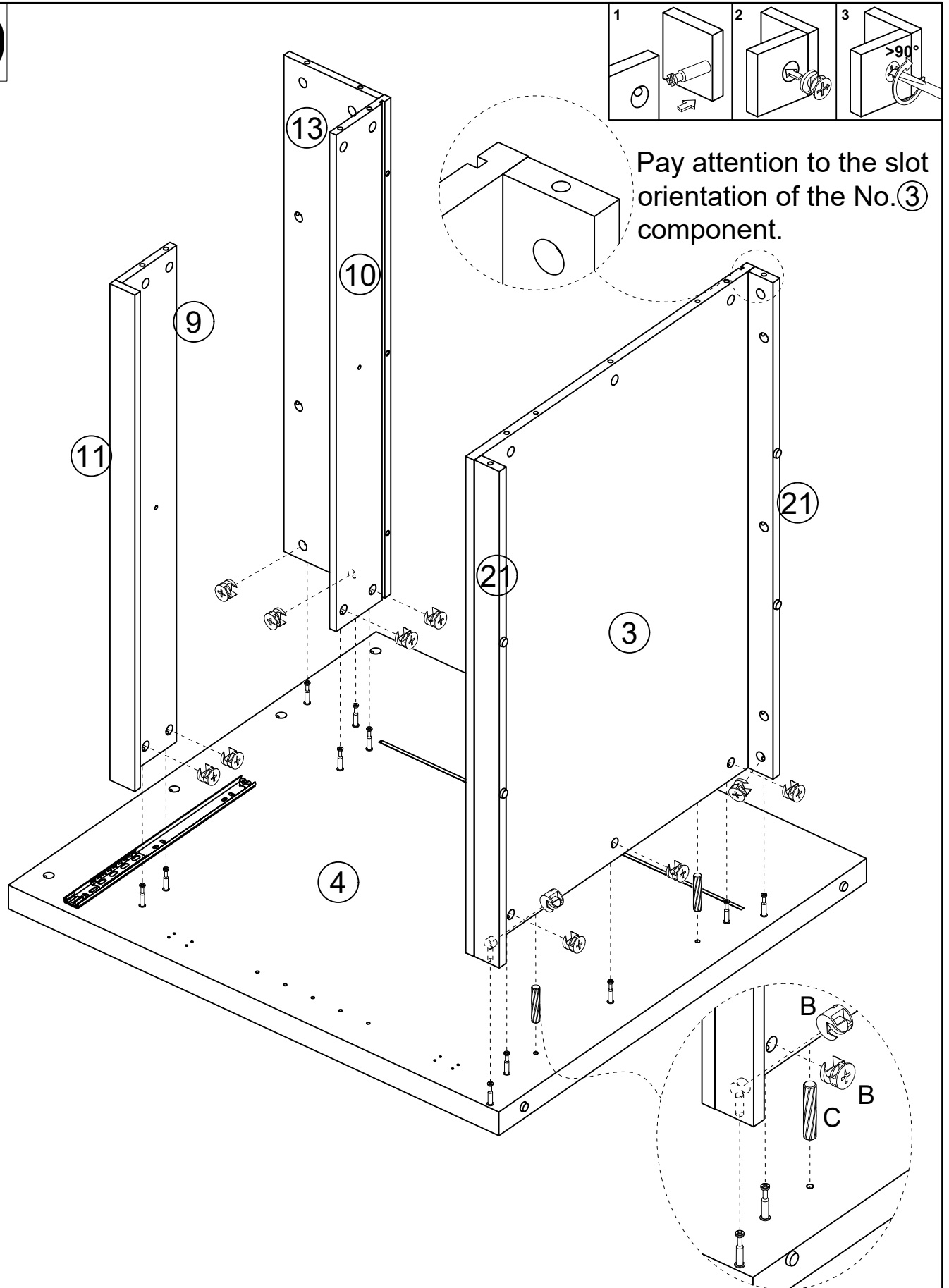

Attach the assembled unit from Step 2, Step 3 and Step 5 to Part #4 with Dowels C*2 and Nuts B*11 as shown. Then turn Nuts B*11 to secure position.



Bx11

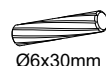

Ø6x30mm

Cx2

10

The thin plate needs to be fully inserted into the groove. If the insertion is not smooth, you can try pressing from the front or the back to make adjustments until the thin plate is fully inserted into the groove.

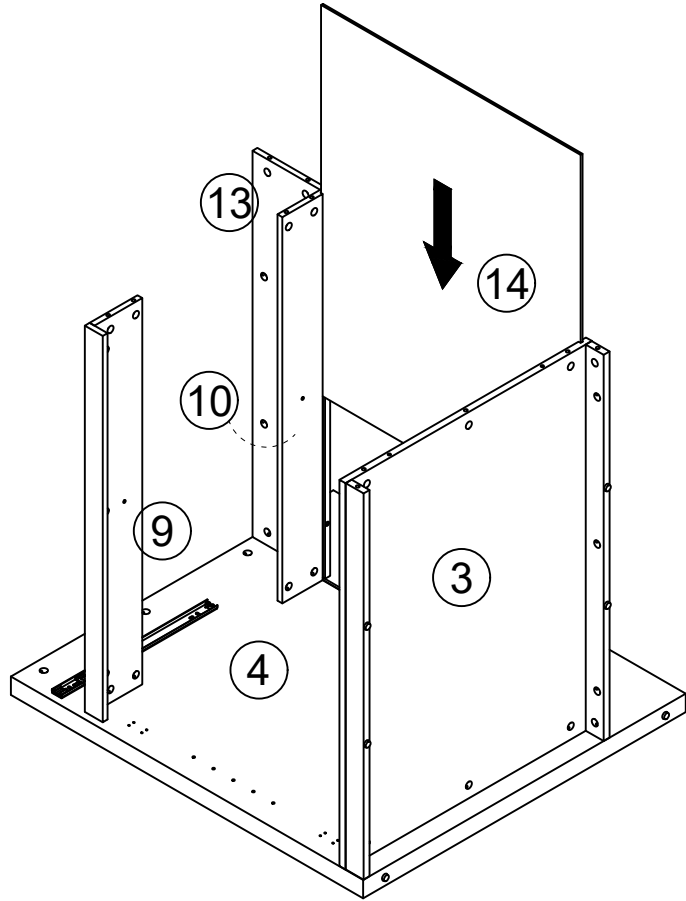

Insert Part #14 into the grooves of the assembled unit as shown.

11

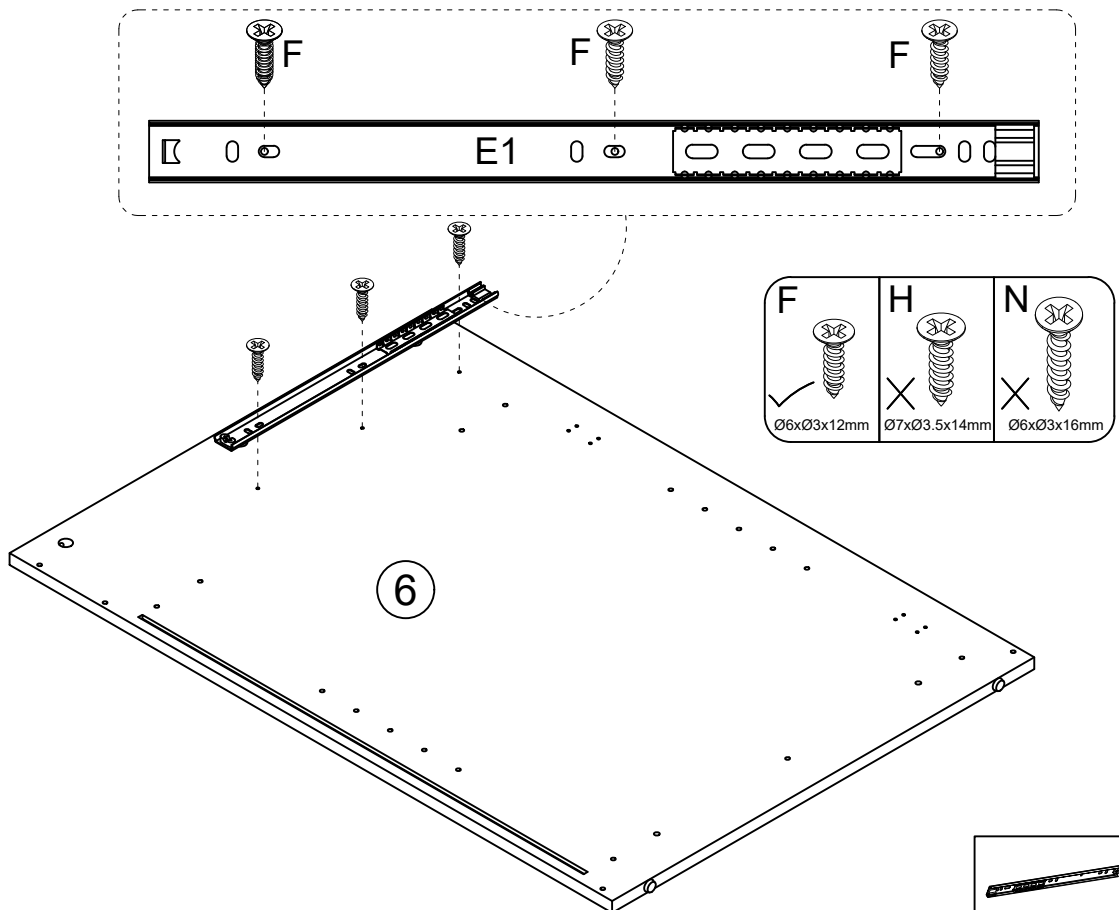

Install the outer rail E1 on Part #6 with Screws F*3 as shown.

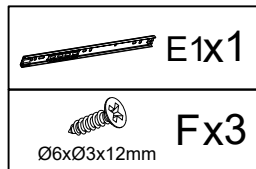

12

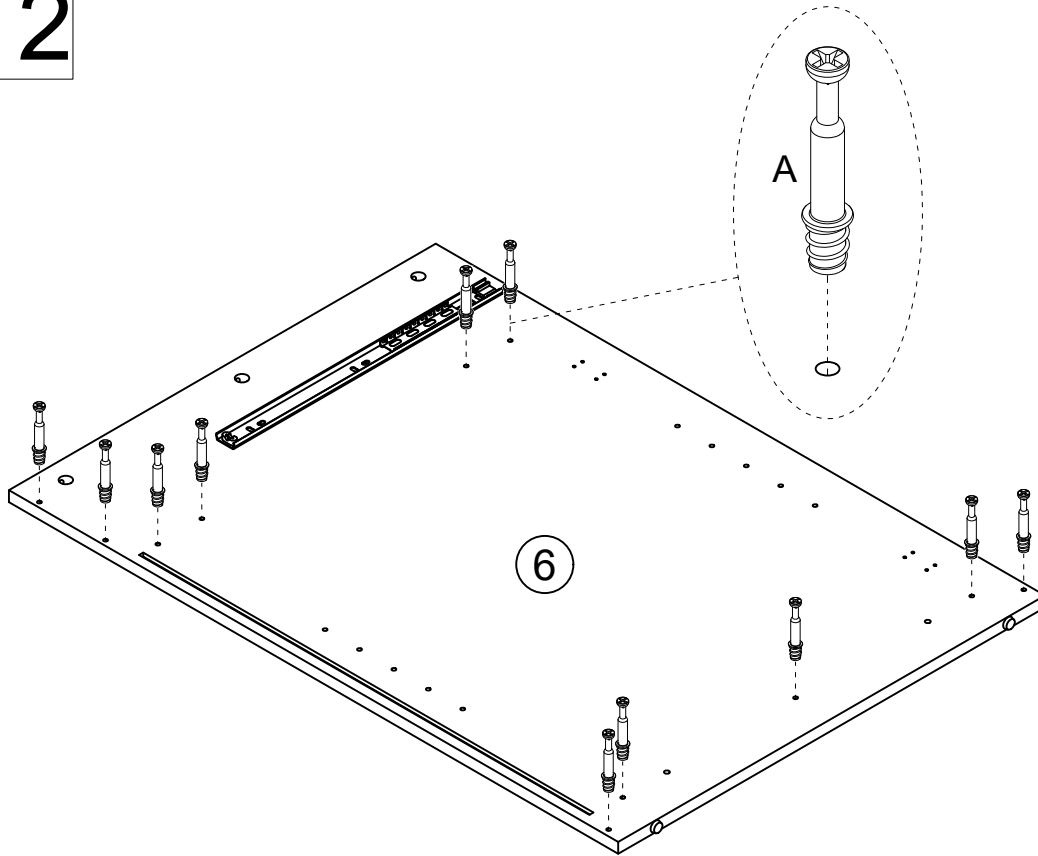
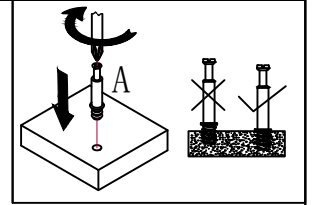

Install Cam Bolt A*11 on Part #6 as shown.



13

Pay attention to the direction of the slide rail and the slot.

The thin plate needs to be fully inserted into the groove. If the insertion is not smooth, you can try pressing from the front or the back to make adjustments until the thin plate is fully inserted into the groove.

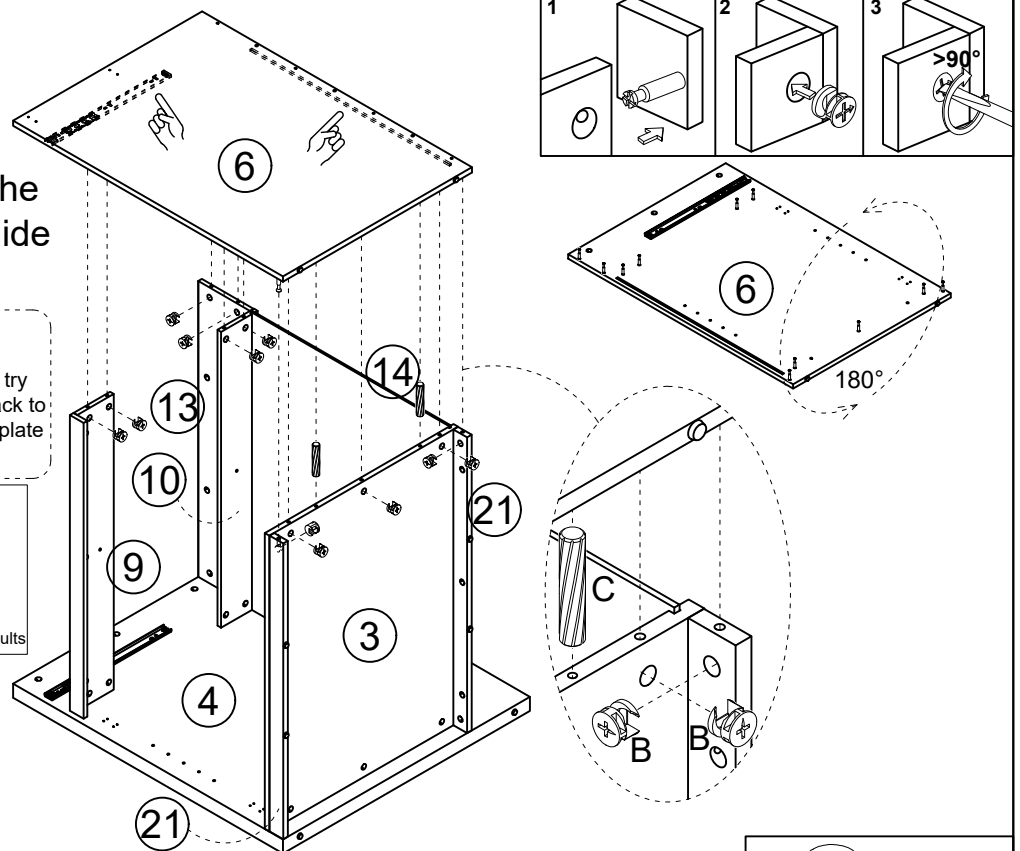
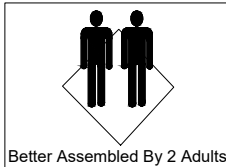

Turn Part #6 180°.

Then attach Part #6 to the assembled unit with Dowels C*2 and Nuts B*11 as shown. Turn Nuts B*11 to secure position. This step should be carried out by two adults.

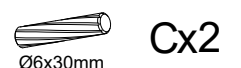

14

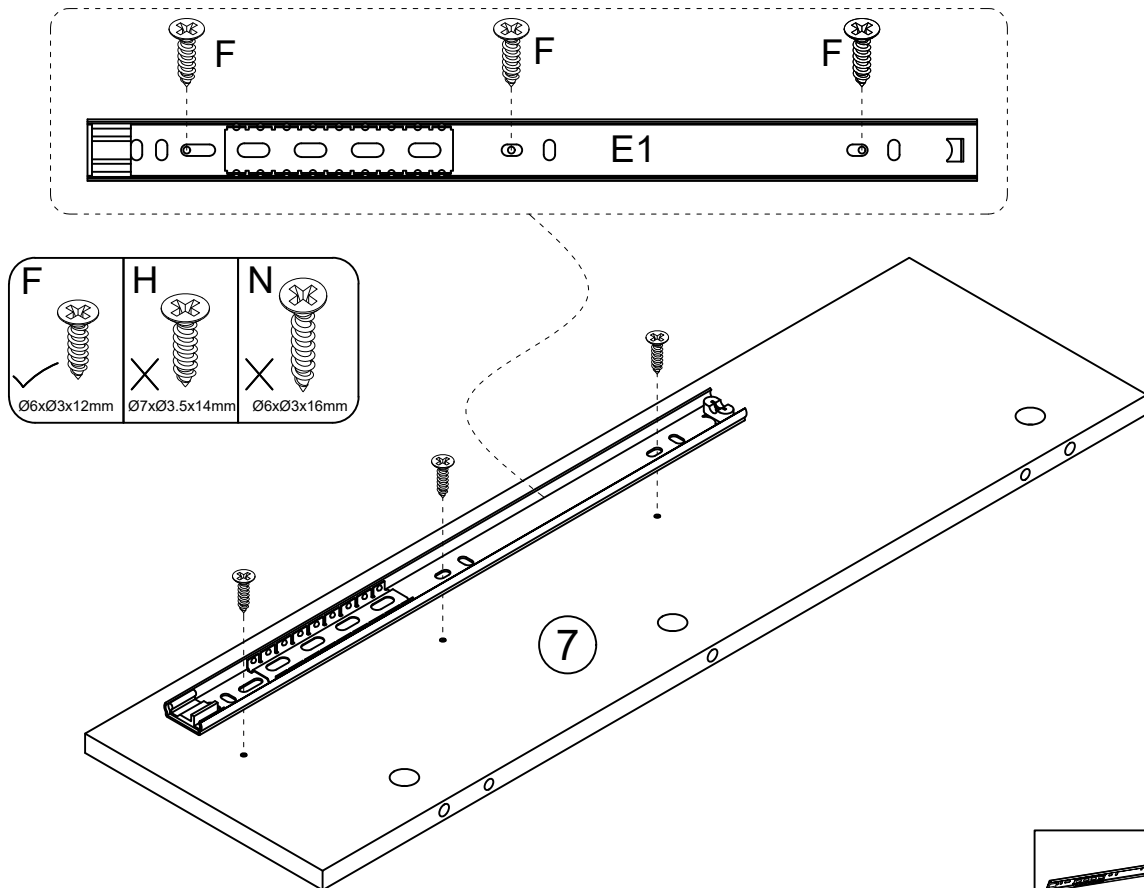

Install the outer rail E1 on Part #7 with Screws F*3 as shown.

15

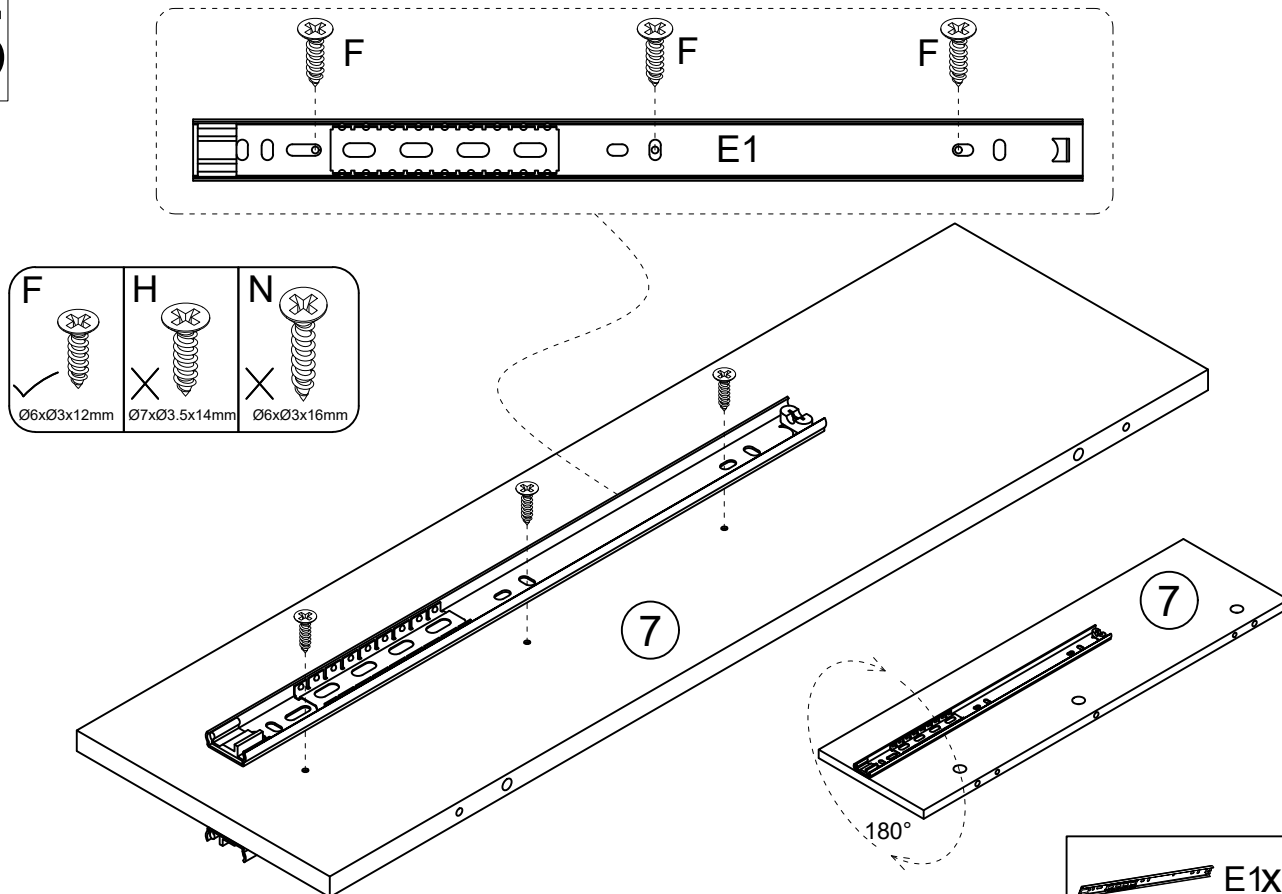

Turn Part #7 180°.

Then install the outer rail E1 on Part #7 with Screws F*3 as shown.

16

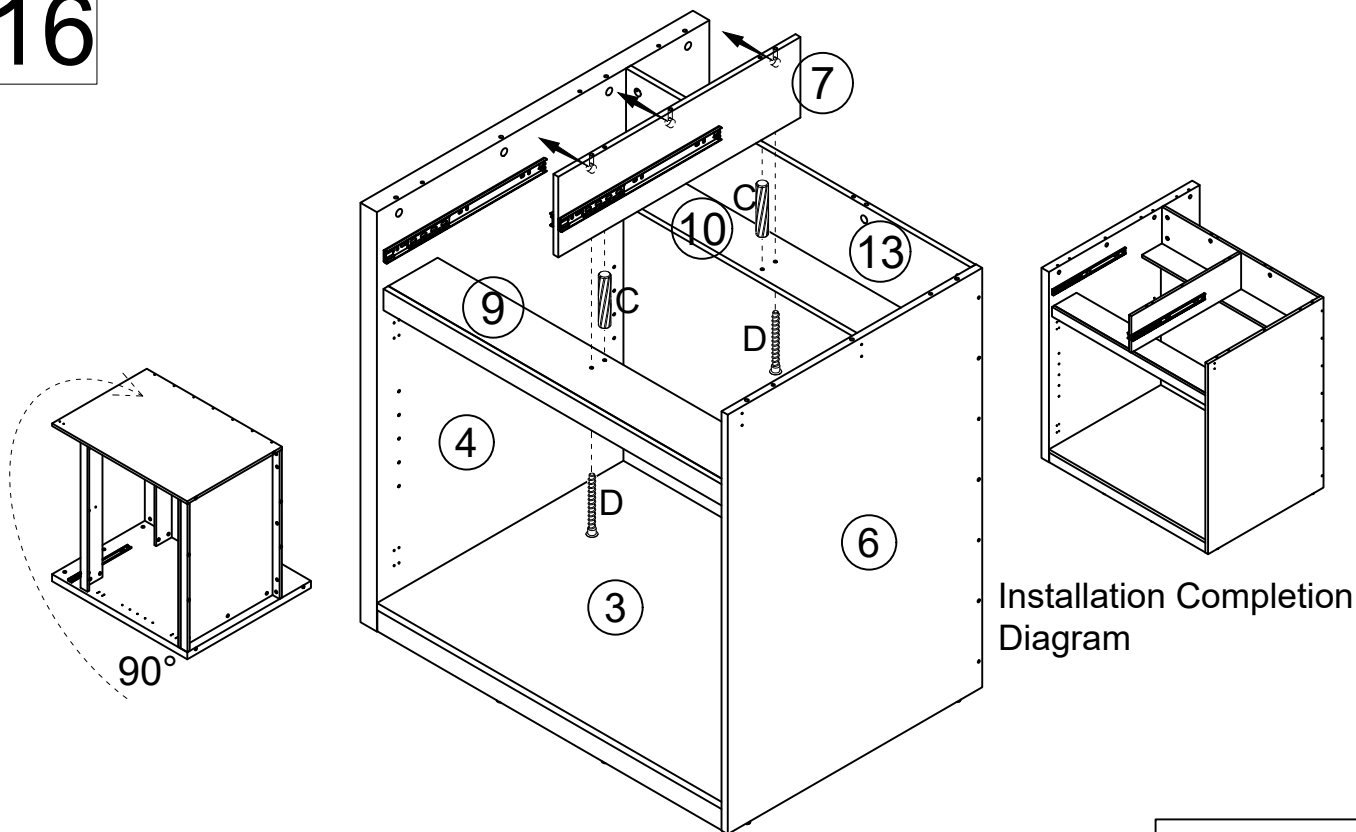

Turn the assembled unit from Step 13 90°. Attach Part #7 to Part #9&10 with Dowels C*2 and Screws D*2 as shown.

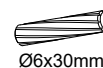

Cx2

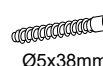

Dx2

17

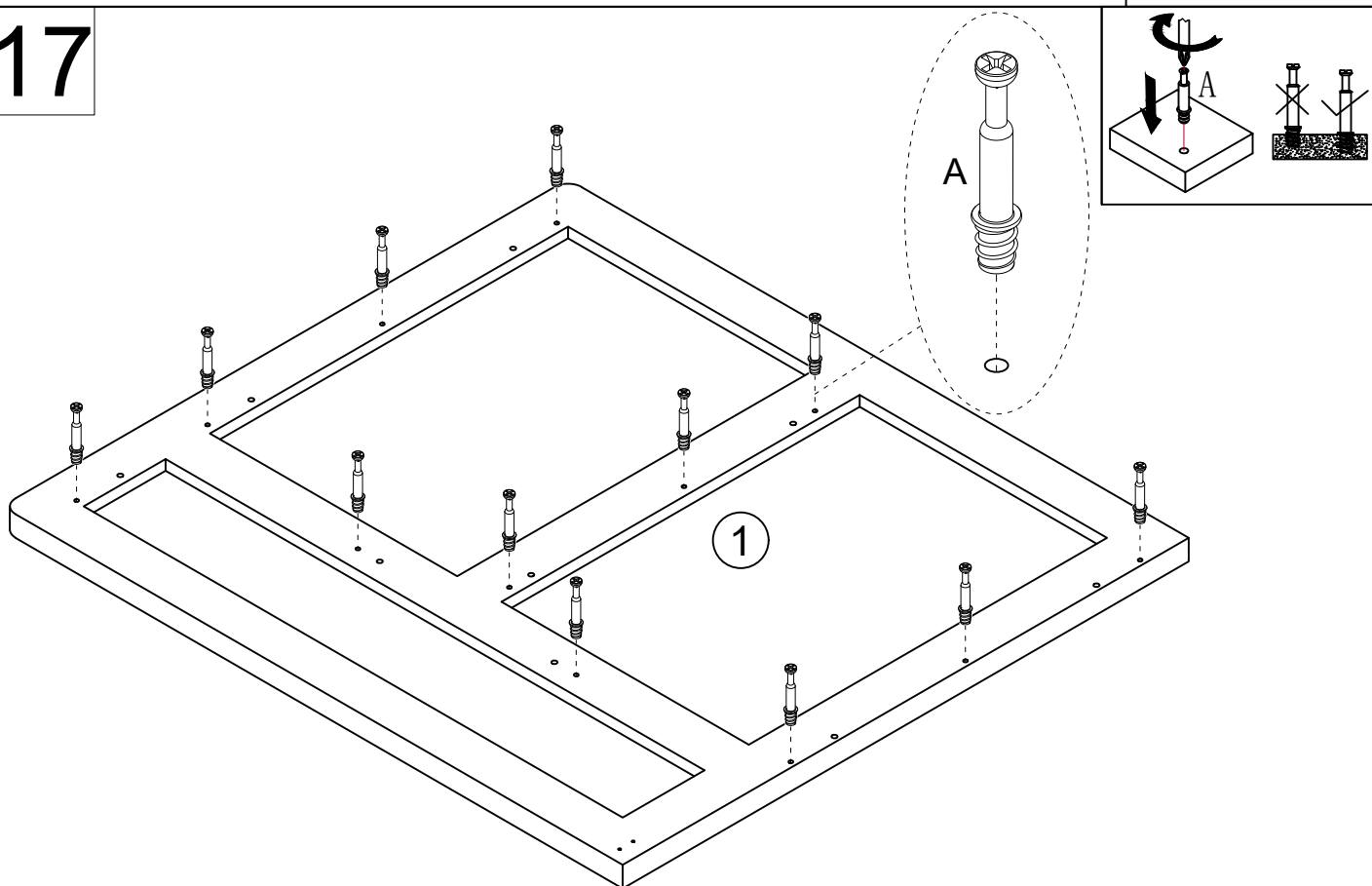

Install Cam Bolt A*12 on Part #1 as shown.

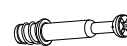

Ax12

18

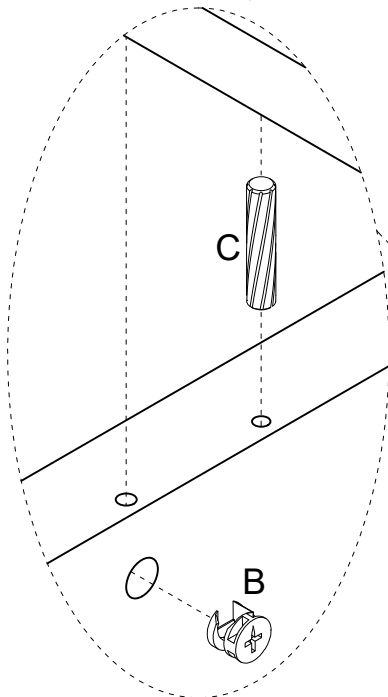
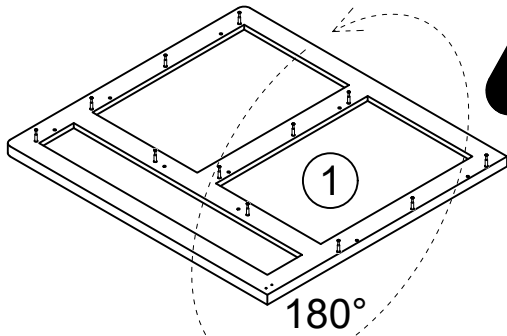
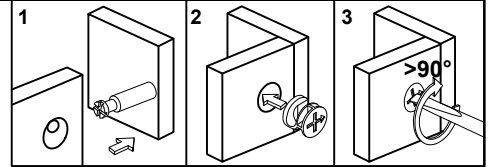

The thin plate needs to be fully inserted into the groove. If the insertion is not smooth, you can try pressing from the front or the back to make adjustments until the thin plate is fully inserted into the groove.

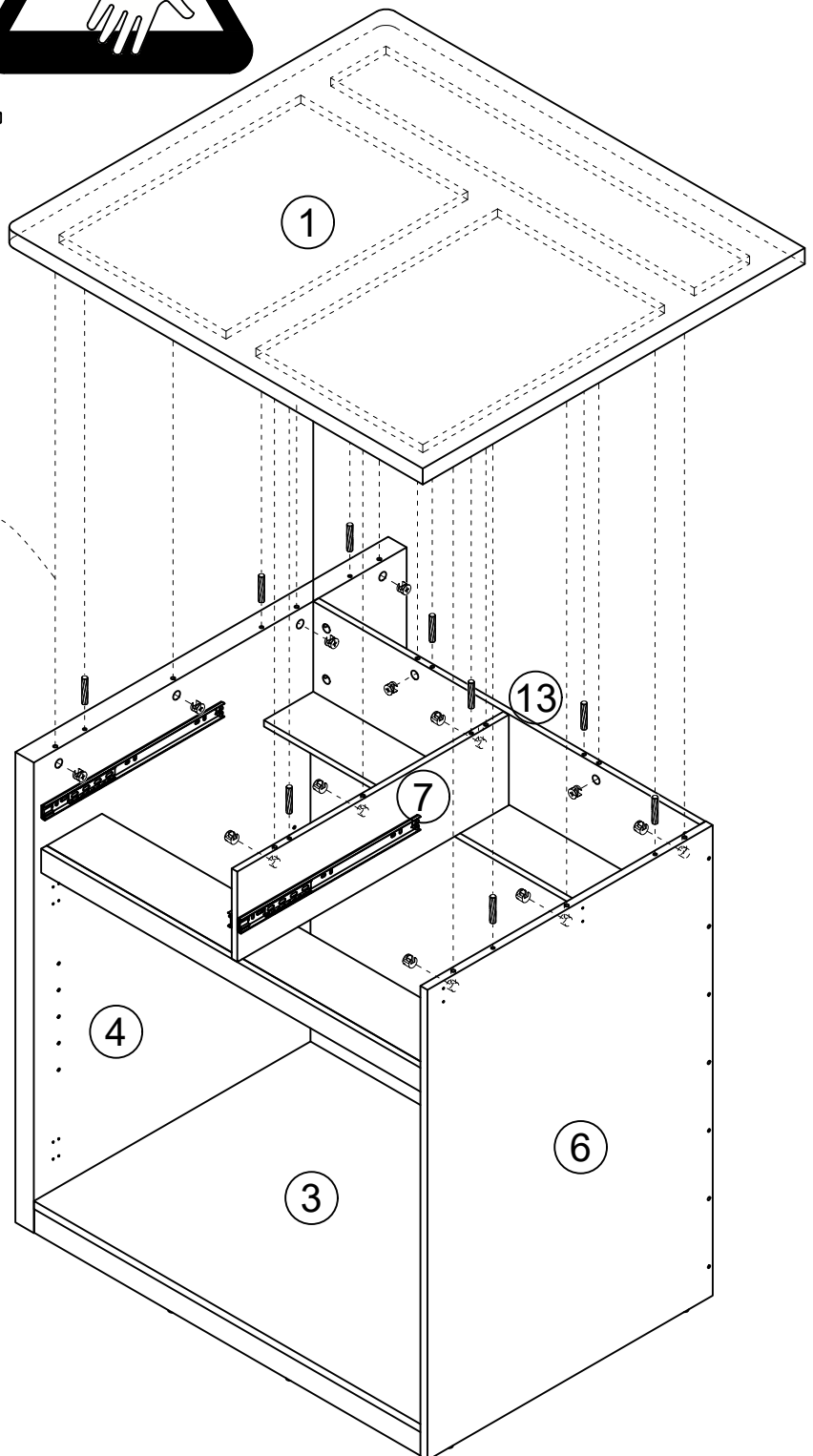
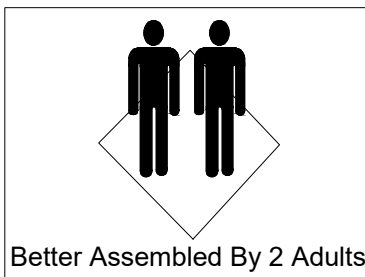

Turn Part #1 180°.

Attach Part #1 to the assembled unit with Dowels C*9 and Nuts B*12 as shown. Turn Nuts B*12 to secure position.

This step should be carried out by two adults.

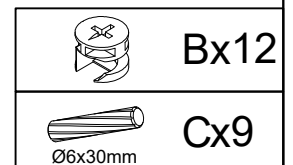

19

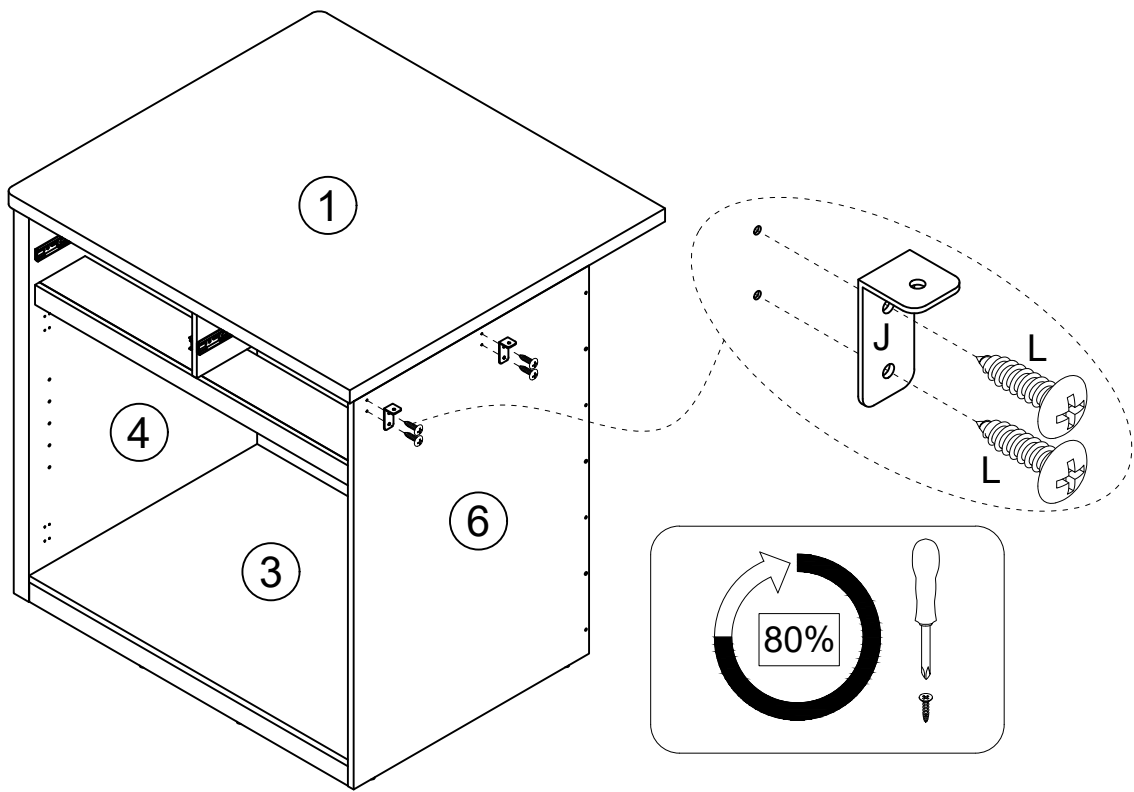

Install J*2 on Part #6 with Screws L*4 as shown.

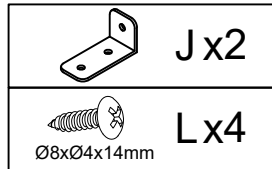

20

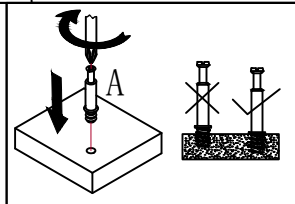
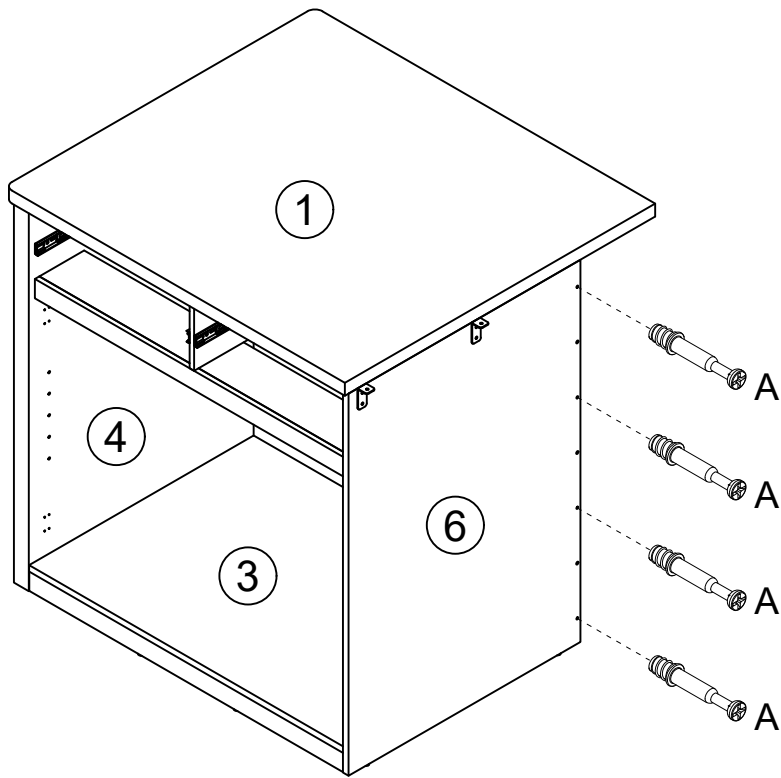

Install Cam Bolt A*4 on Part #6 as shown.

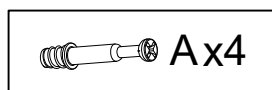

21

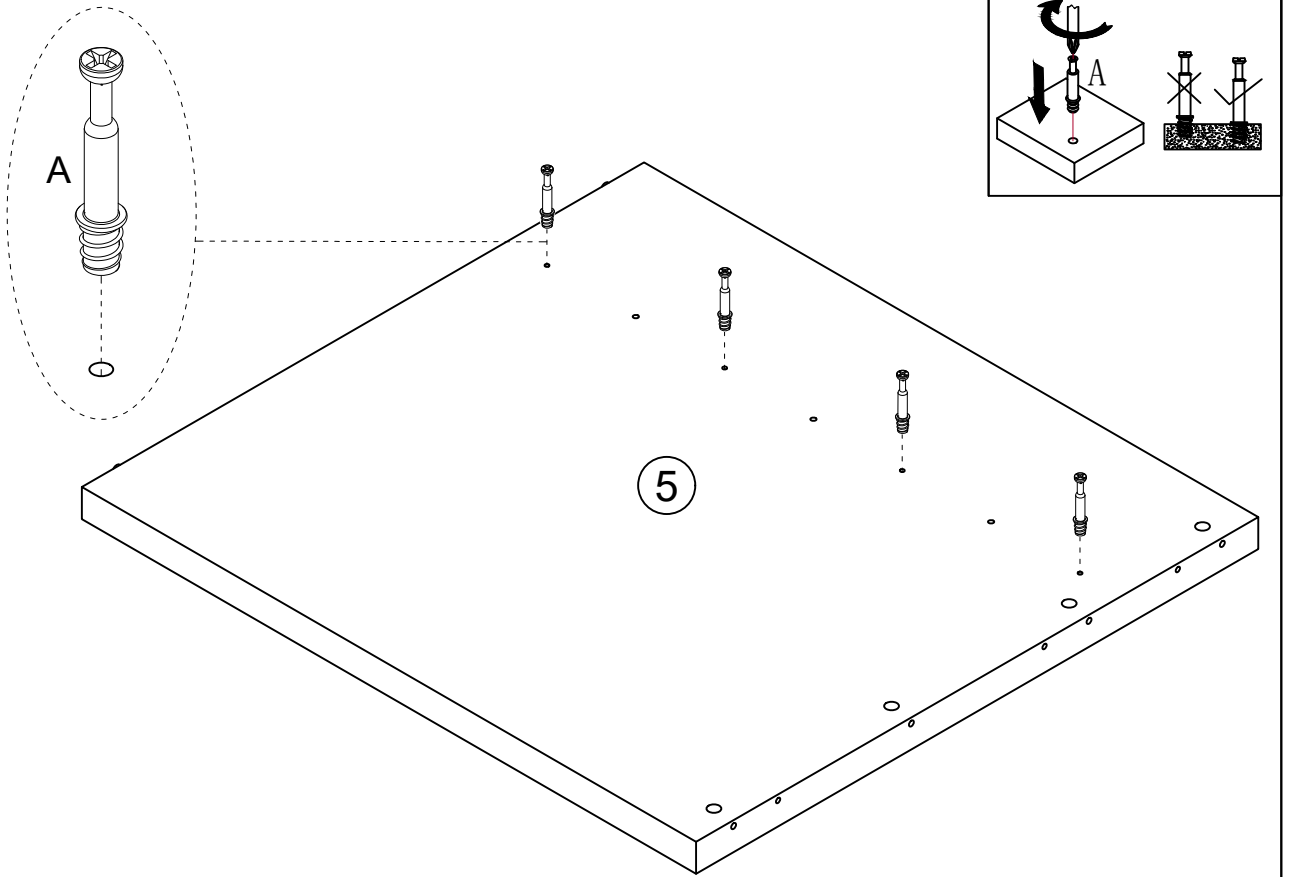

Install Cam Bolt A*4 on Part #5 as shown.

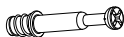
 A x 4

22

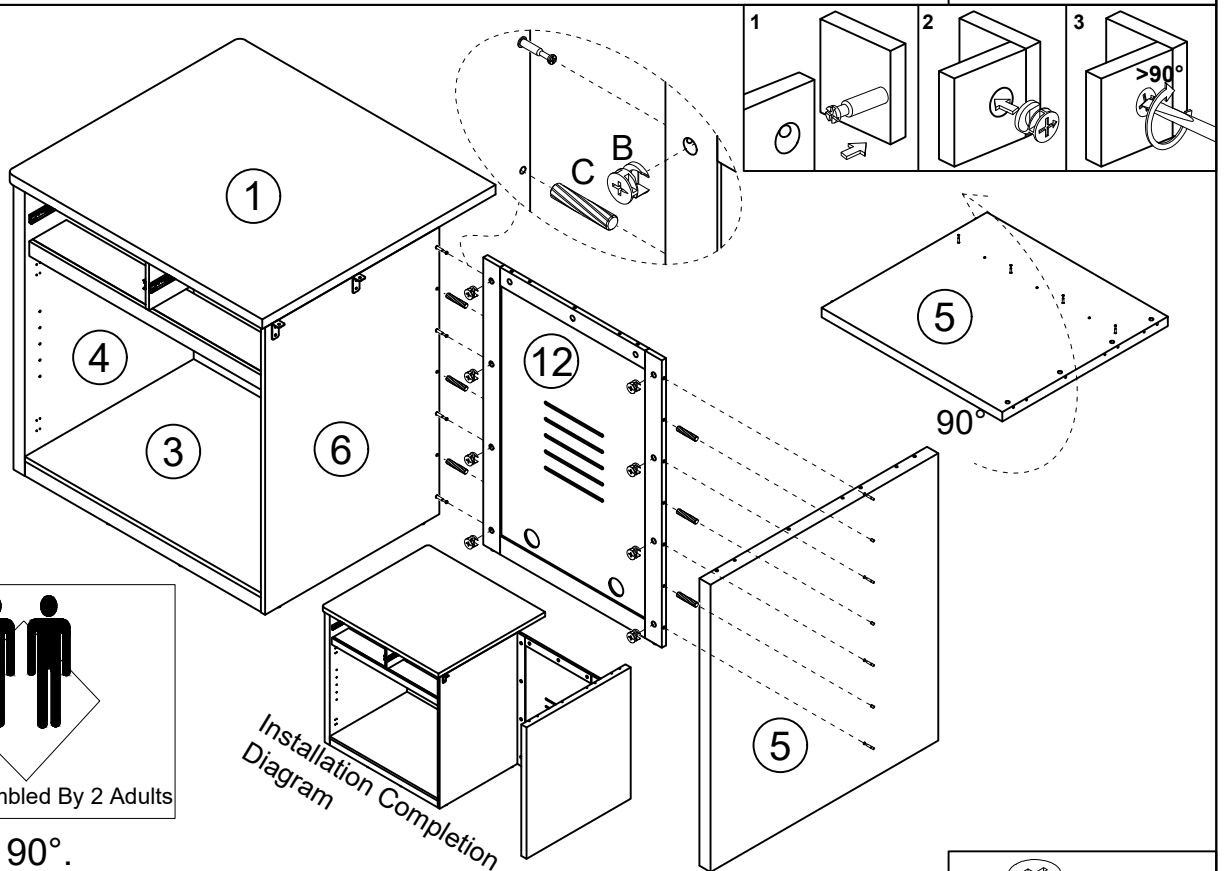

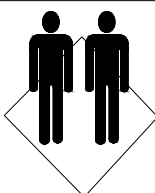
 Better Assembled By 2 Adults

Turn Part #5 90°.

Attach Part #5 and Part #6 to Part #12 with Dowels C*6 and Nuts B*8 as shown. Then turn Nuts B*8 to secure position.

This step should be carried out by two adults.

 B x 8

 C x 6
Ø6x30mm

23

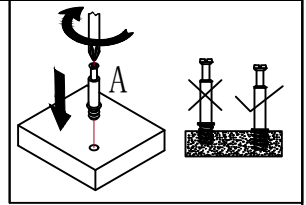
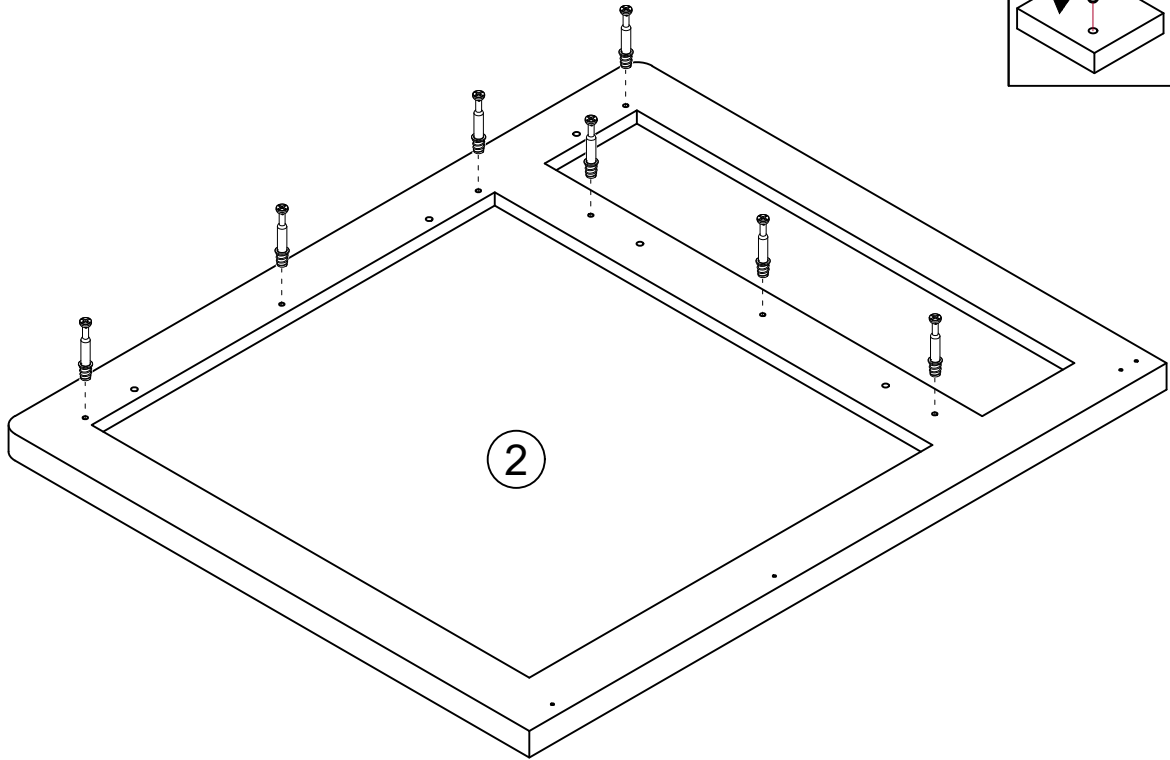

Install Cam Bolt A*7 on Part #2 as shown.

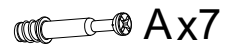

24

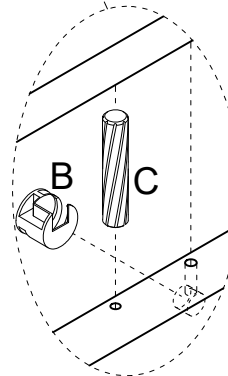
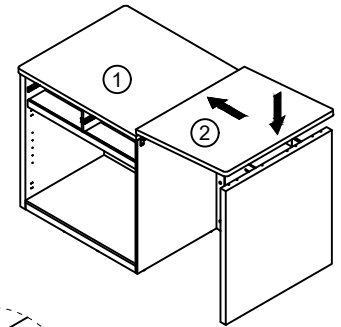
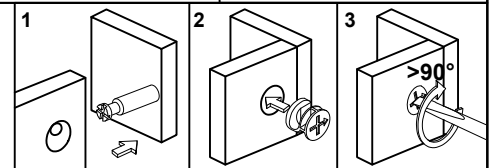
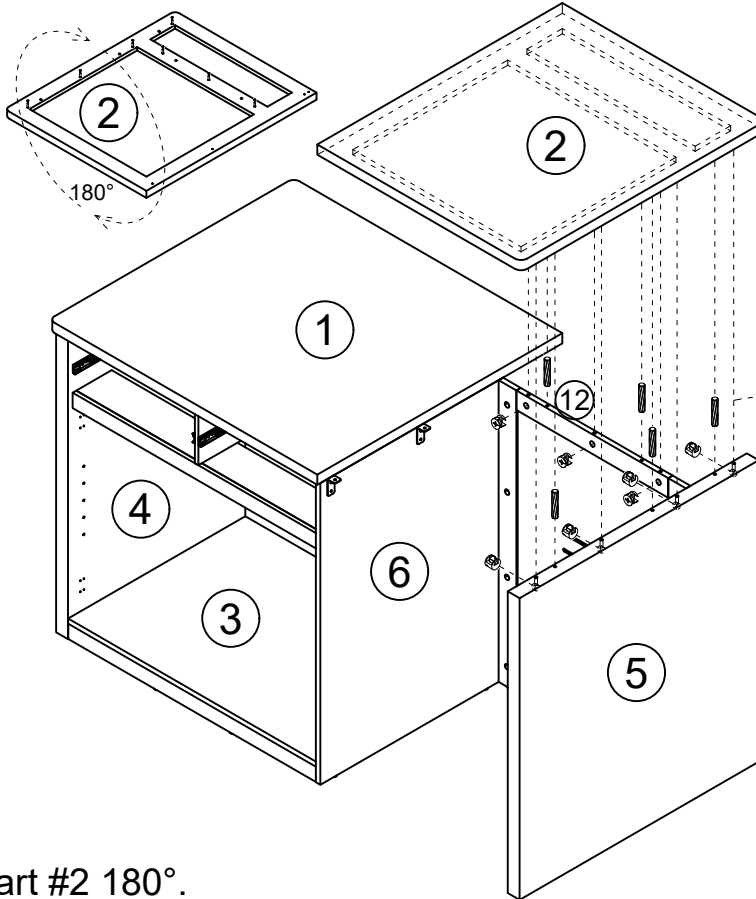

During installation, as shown in the picture: slightly tilt component (2) to align it with component (1), and then press down.

Turn Part #2 180°.

Attach Part #2 to the assembled unit with Dowels C*5 and Nuts B*7 as shown. Then turn Nuts B*7 to secure position.

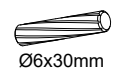



Cx5

25

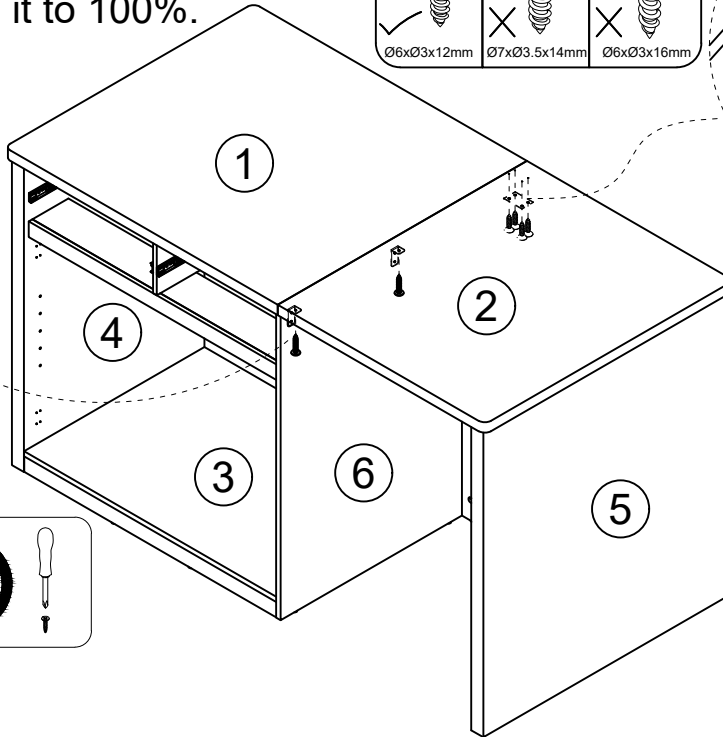
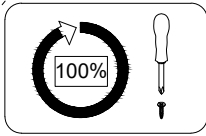
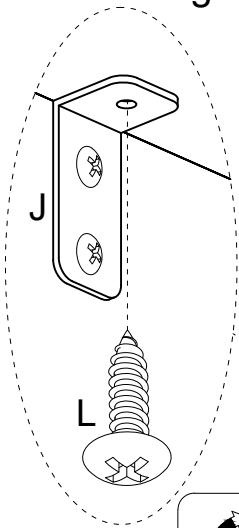
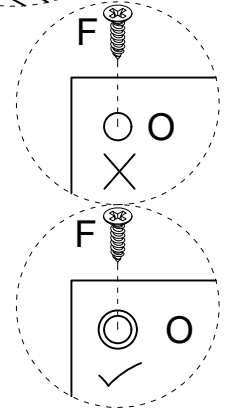
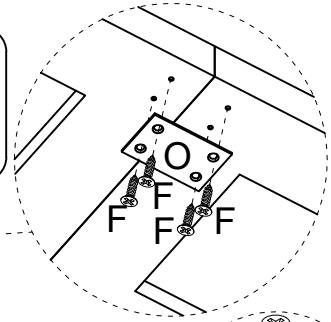
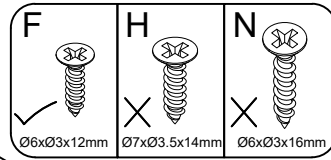
After aligning the panel, check the screw **L** on component **J** and tighten it to 100%.



Install O on Part #1&2 with Screws F*4 as shown.
Secure J*2 to Part #2 with Screws L*2 as shown.

	Fx4 Ø6xØ3x12mm
	Lx2 Ø8xØ4x14mm
	Ox1

26

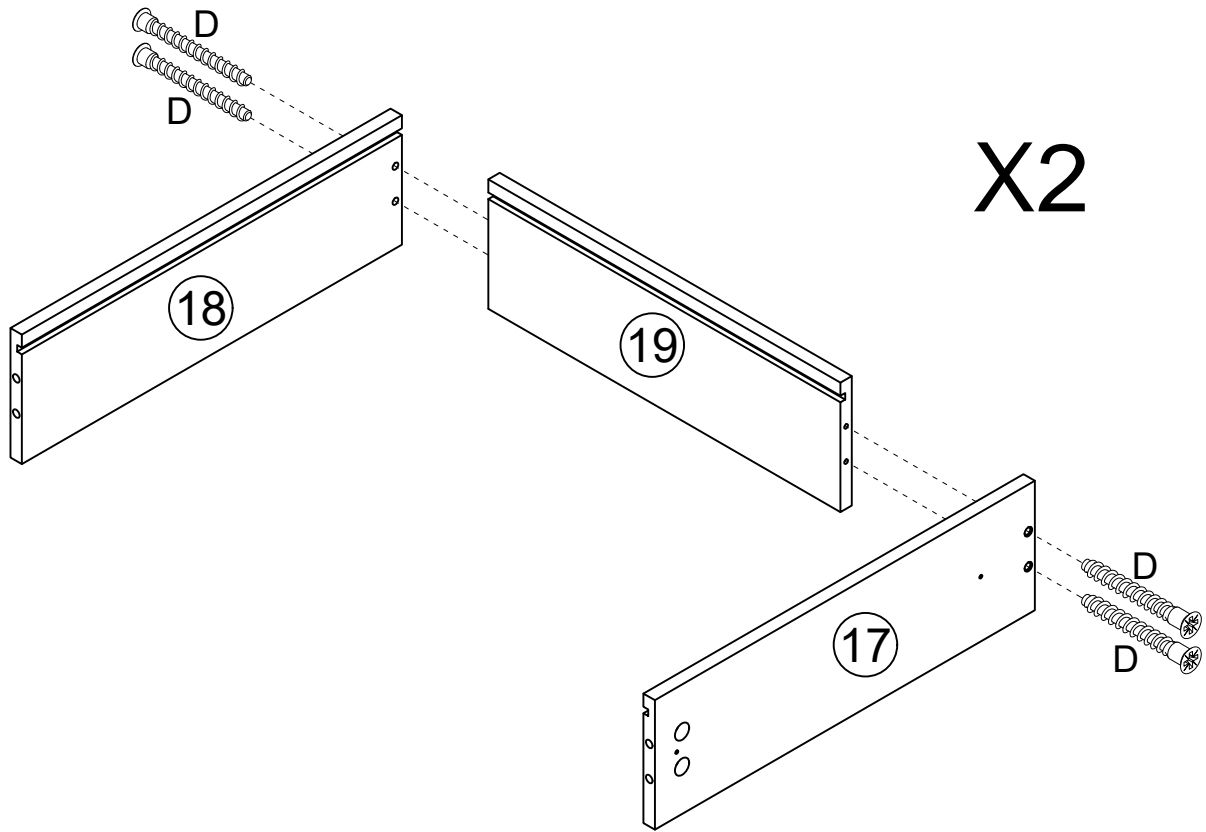

X2

Attach Part #17*2 and Part #18*2 to Part #19*2 with Screws D*8 as shown.

	Dx8 Ø5x38mm
---	-----------------------

27

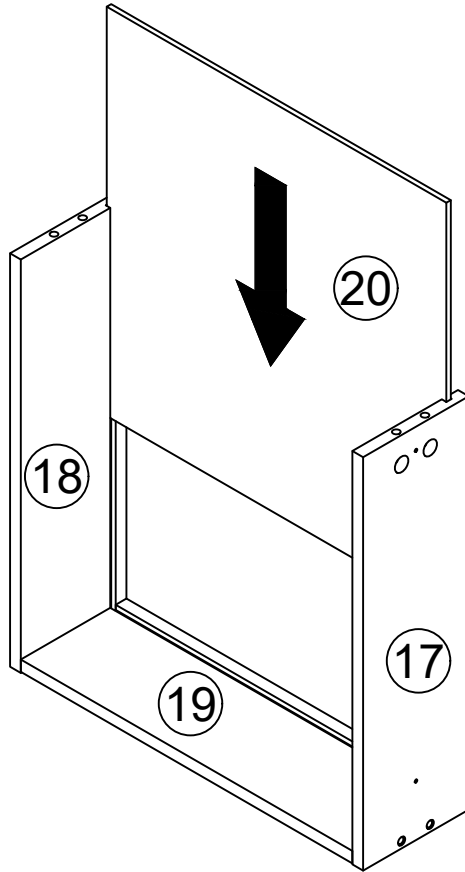

X2

The thin plate needs to be fully inserted into the groove. If the insertion is not smooth, you can try pressing from the front or the back to make adjustments until the thin plate is fully inserted into the groove.

Insert Part #20*2 into the grooves of the assembled unit*2 as shown.

28

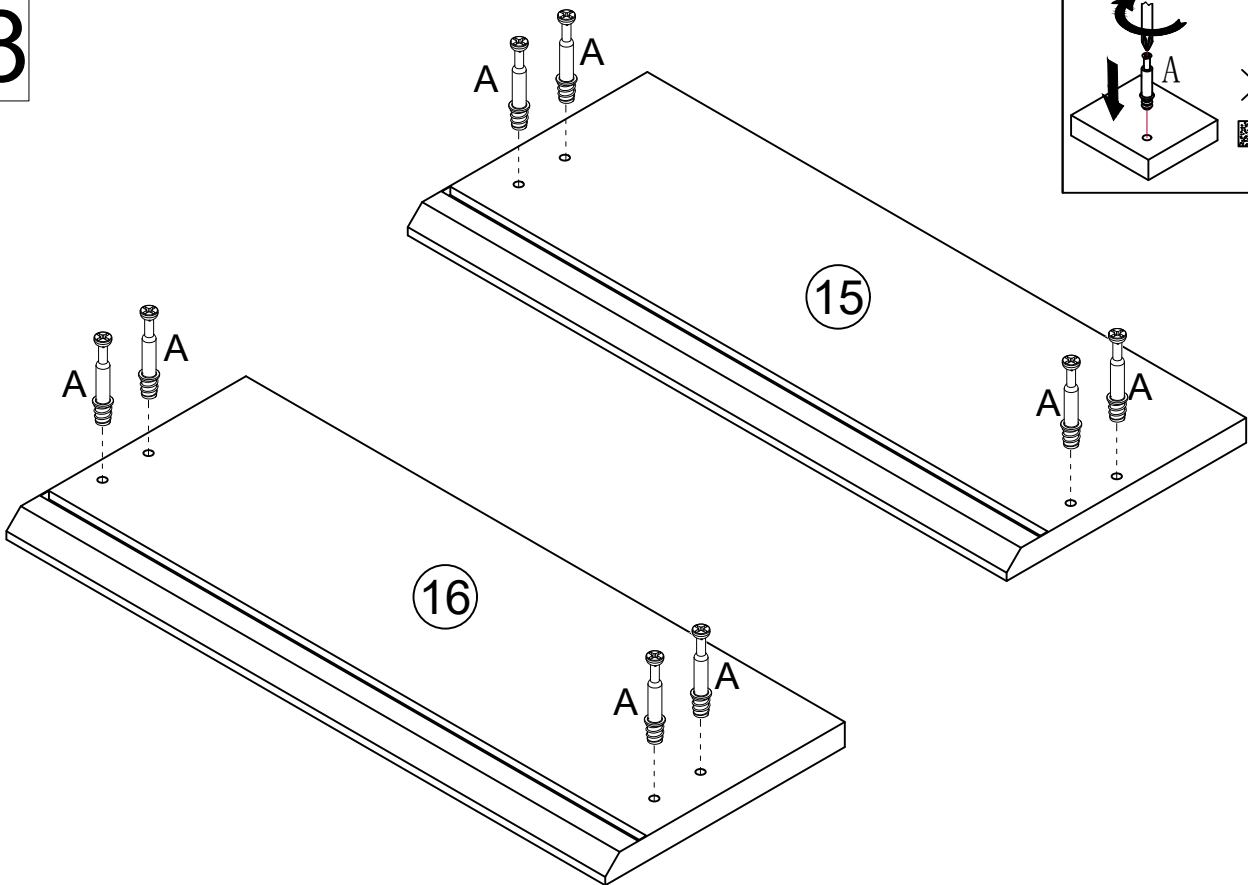

Install Cam Bolt A*8 on Part #15 and Part #16 as shown.

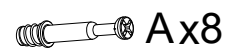

29

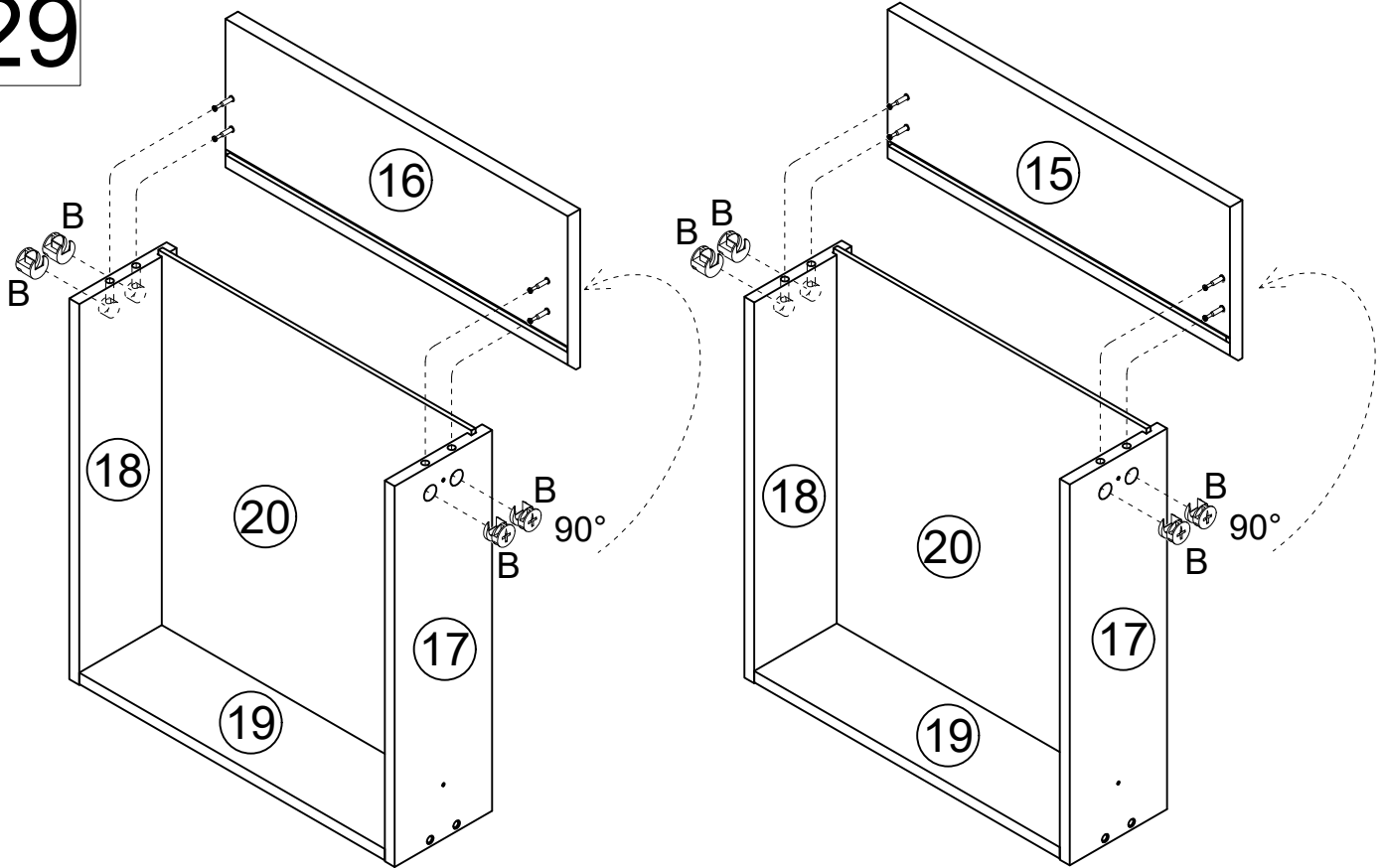

Attach Part #16 and Part #15 to the assembled unit*2 from Step 27 with Nuts B*8 as shown. Then turn Nuts B*8 to secure position.



Bx8

30

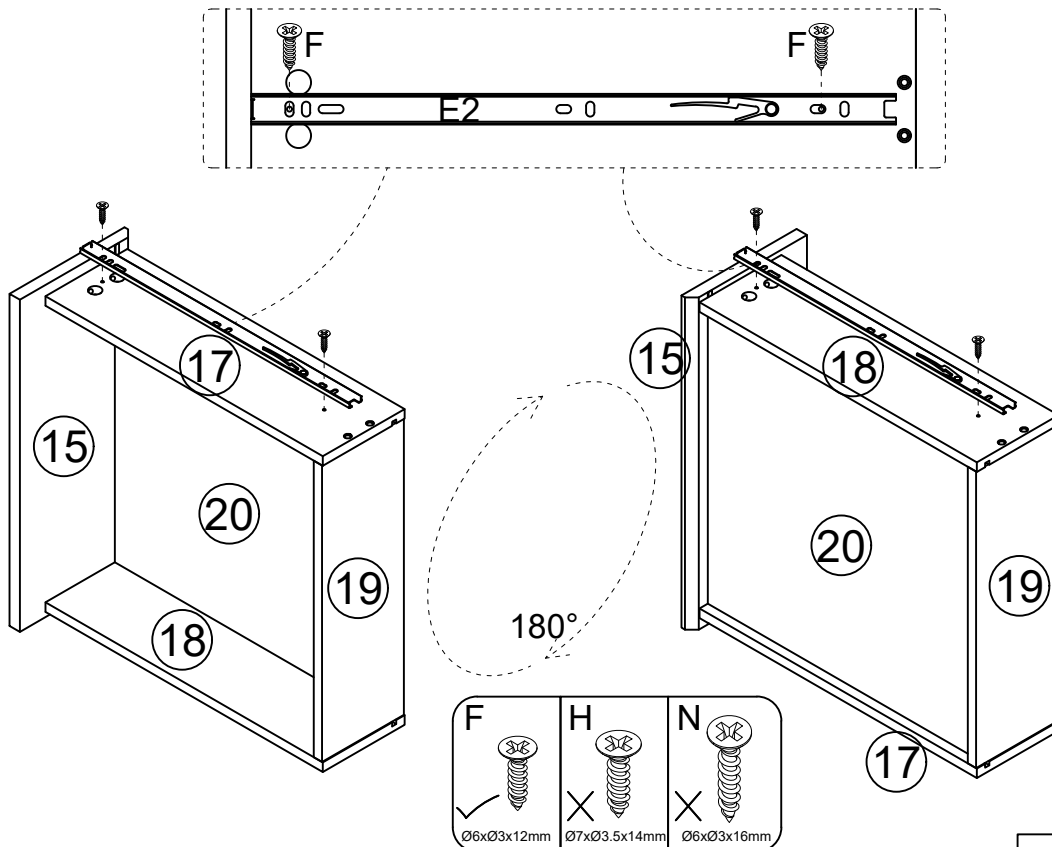

Install the inner rail E2 on Part #17 with Screws F*2 as shown. Turn the drawer 180°. Install the inner rail E2 on Part #18 with Screws F*2 as shown.



Fx4

Ø6xØ3x12mm



E2x2

31

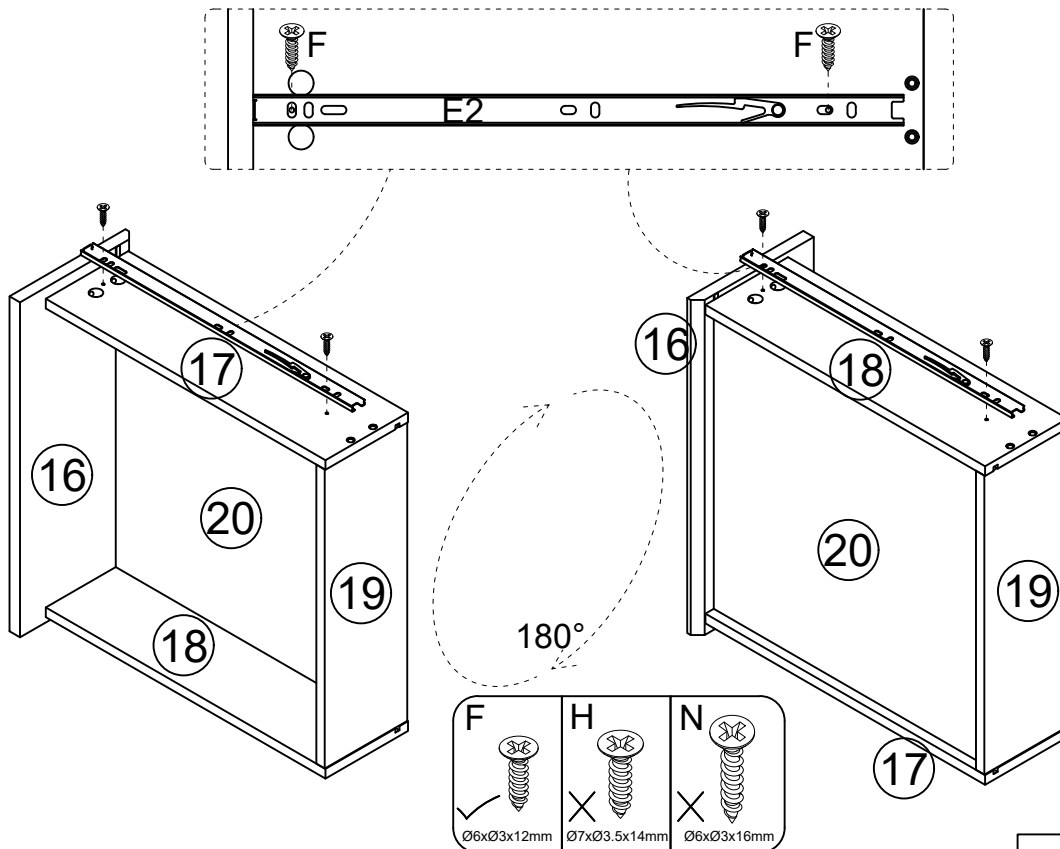

Install the inner rail E2 on Part #17 with Screws F*2 as shown.
 Turn the drawer 180°.
 Install the inner rail E2 on Part #18 with Screws F*2 as shown.

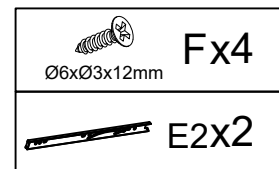

32

Be sure to check the serial number of the drawer panel.

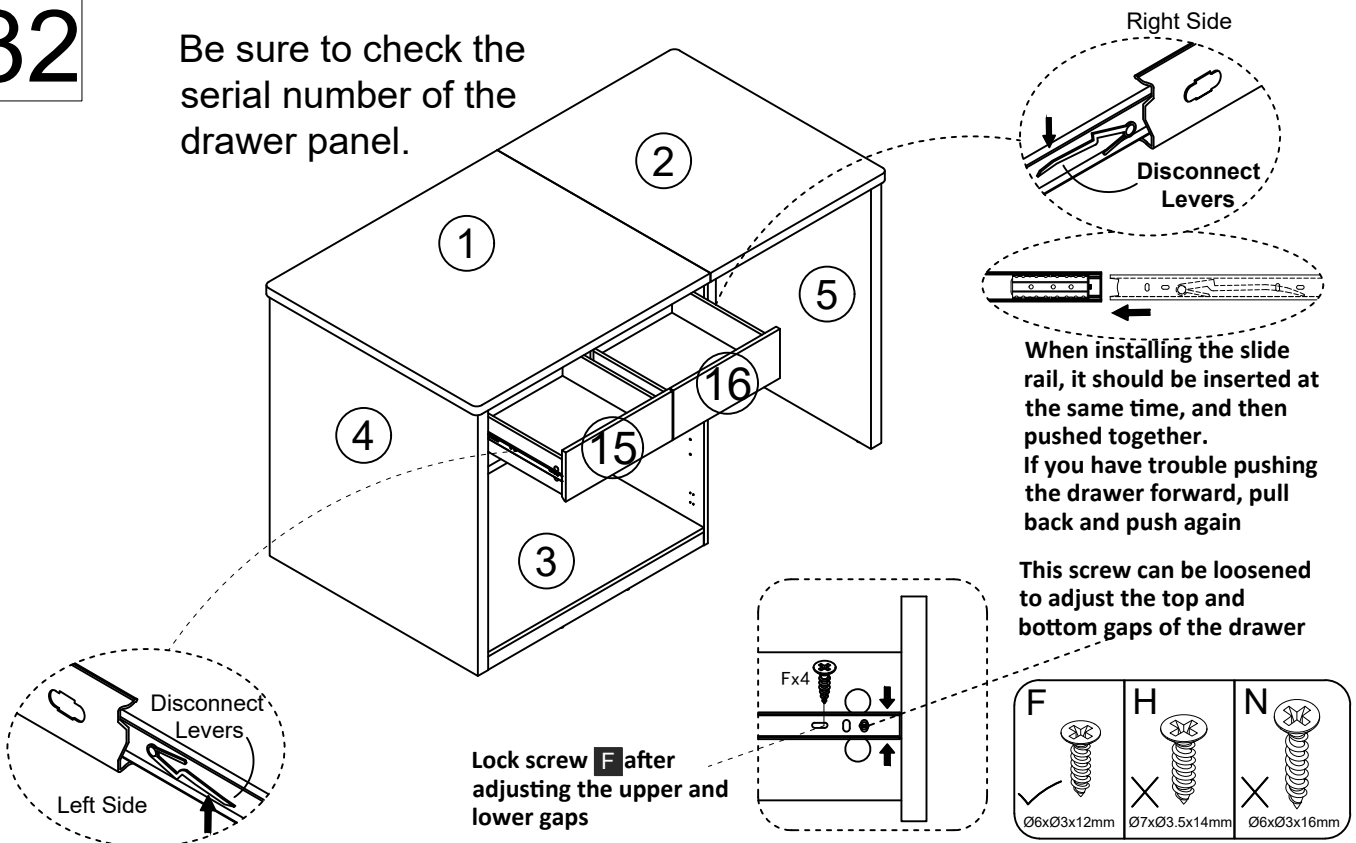

Insert the inner rail E2*4 into the outer rail E1*4 as shown.
 After adjusting the upper and lower gaps, lock Screws F*4 onto the inner slides E2*4 as shown.

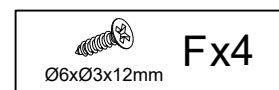

33

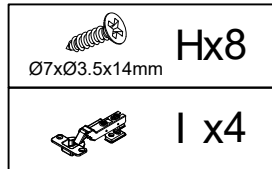
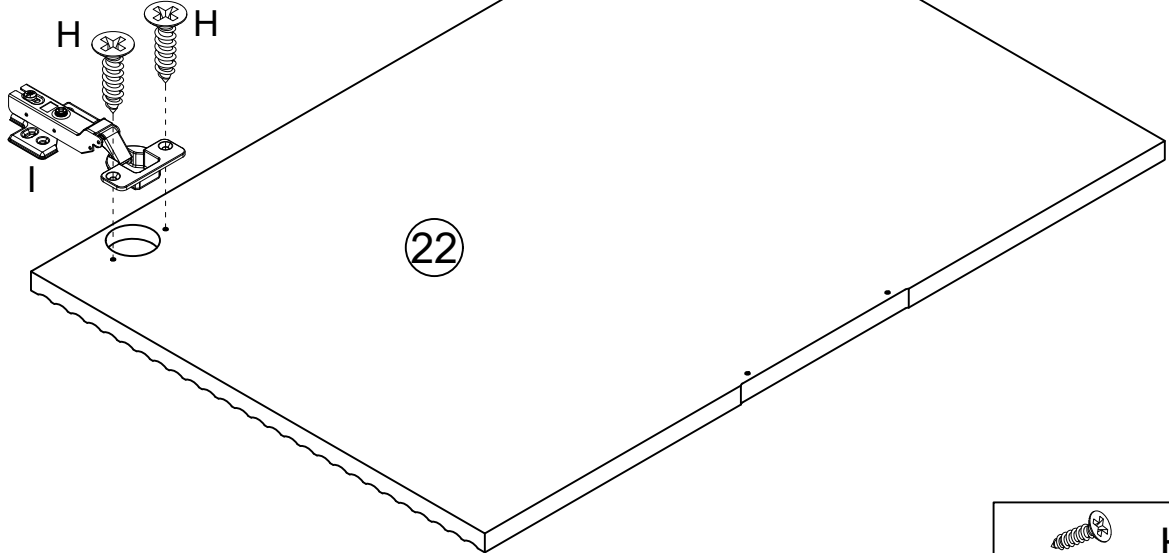
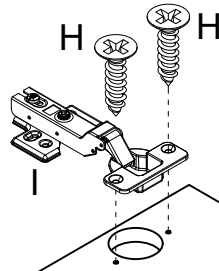
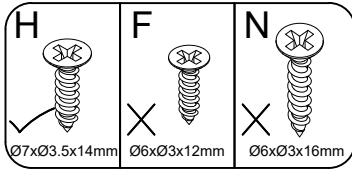

Install hinge I*4 on Part #22*2 with Screws H*8 as shown.

34

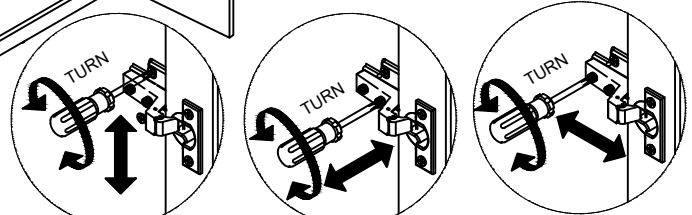
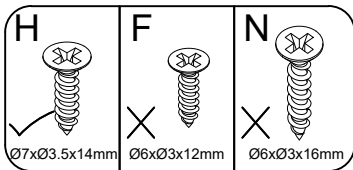
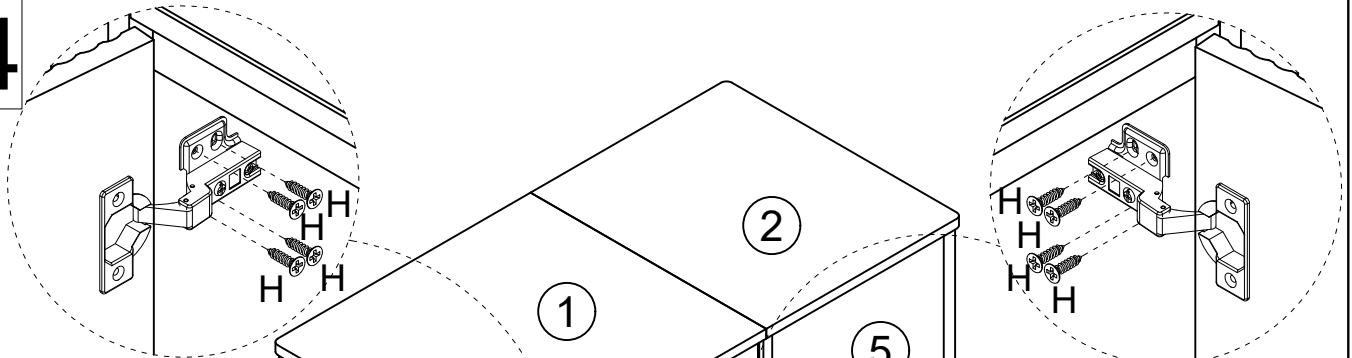

Loosen this screw and push up/down for a slight up-down adjustment of the door.

Loosen this screw for a slight left-right adjustment of the door.

Loosen this screw and push forward/backward for a slight front-back adjustment of the door.

Attach Part #22*2 to the assembled unit with Screws H*16 as shown.



35

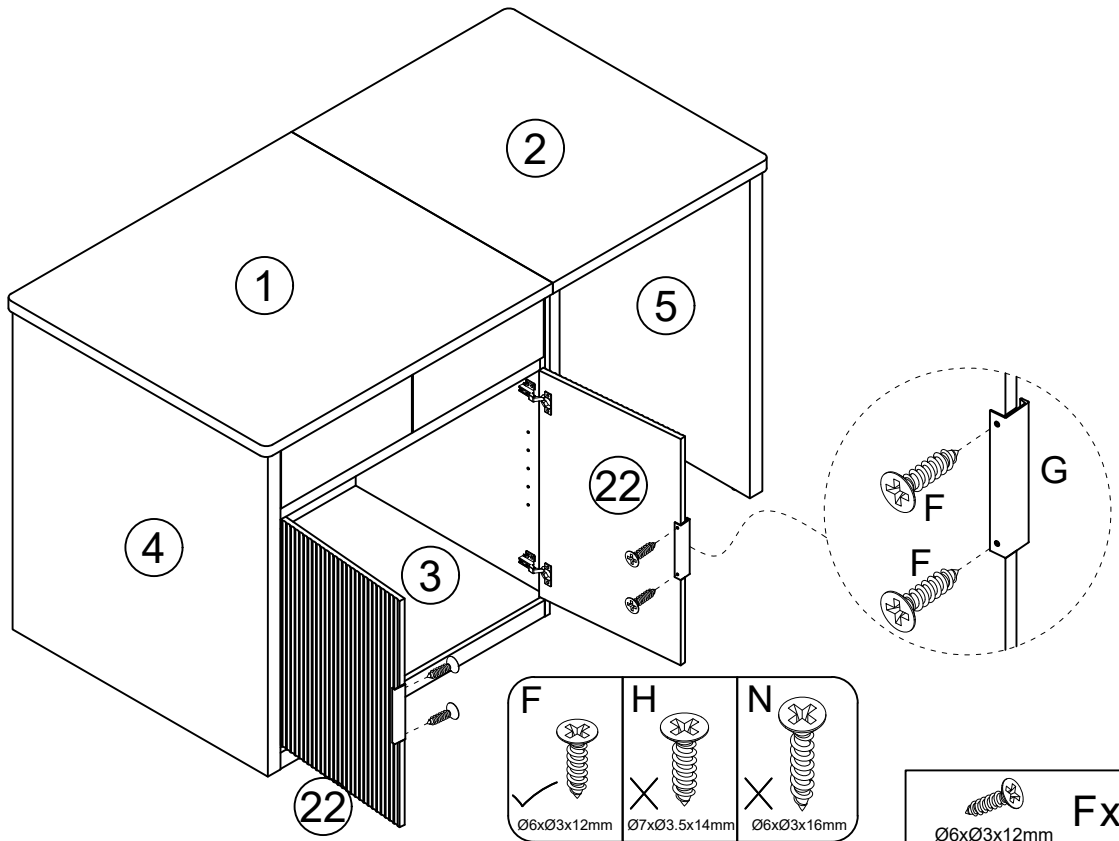

Install handle G*2 on Part #22*2 with Screws F*4 as shown.

36

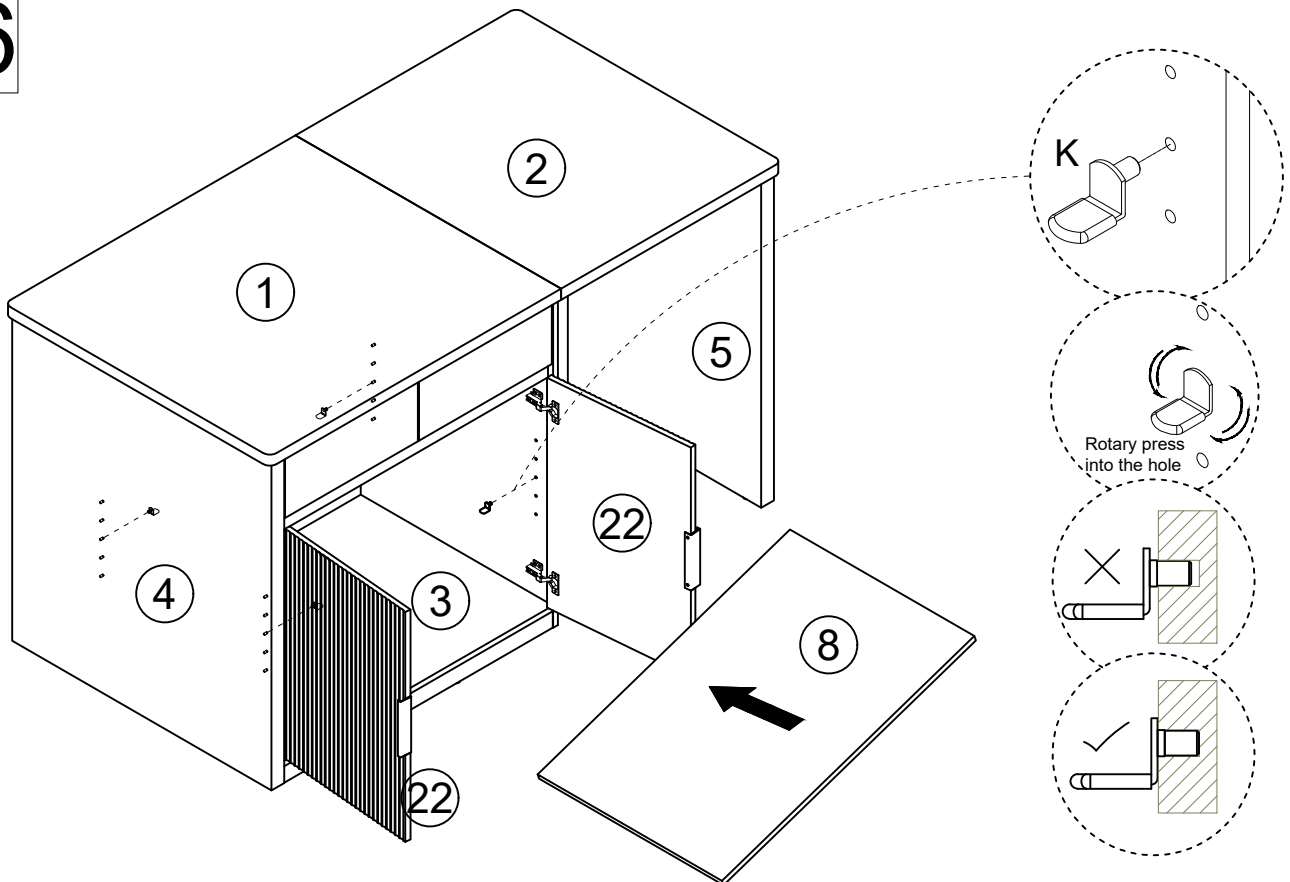

Install K*4 on the assembled unit as shown.
Then put Part #8 on K*4.

37

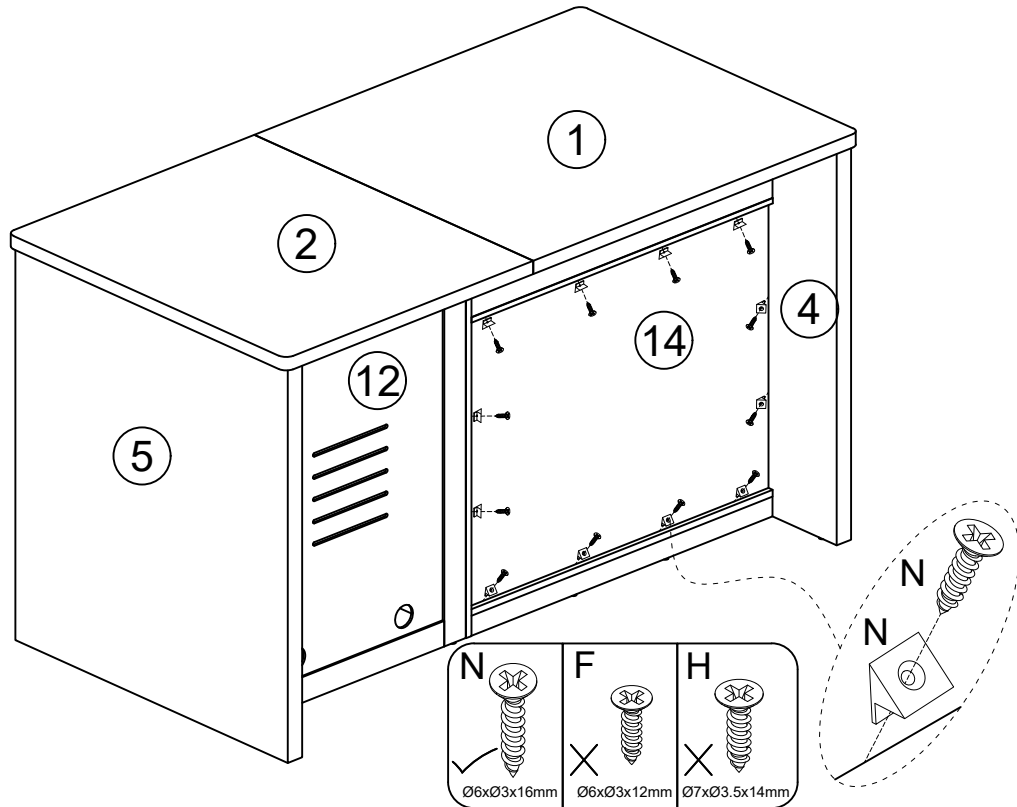

Install N*12 on the assembled unit as shown.



38

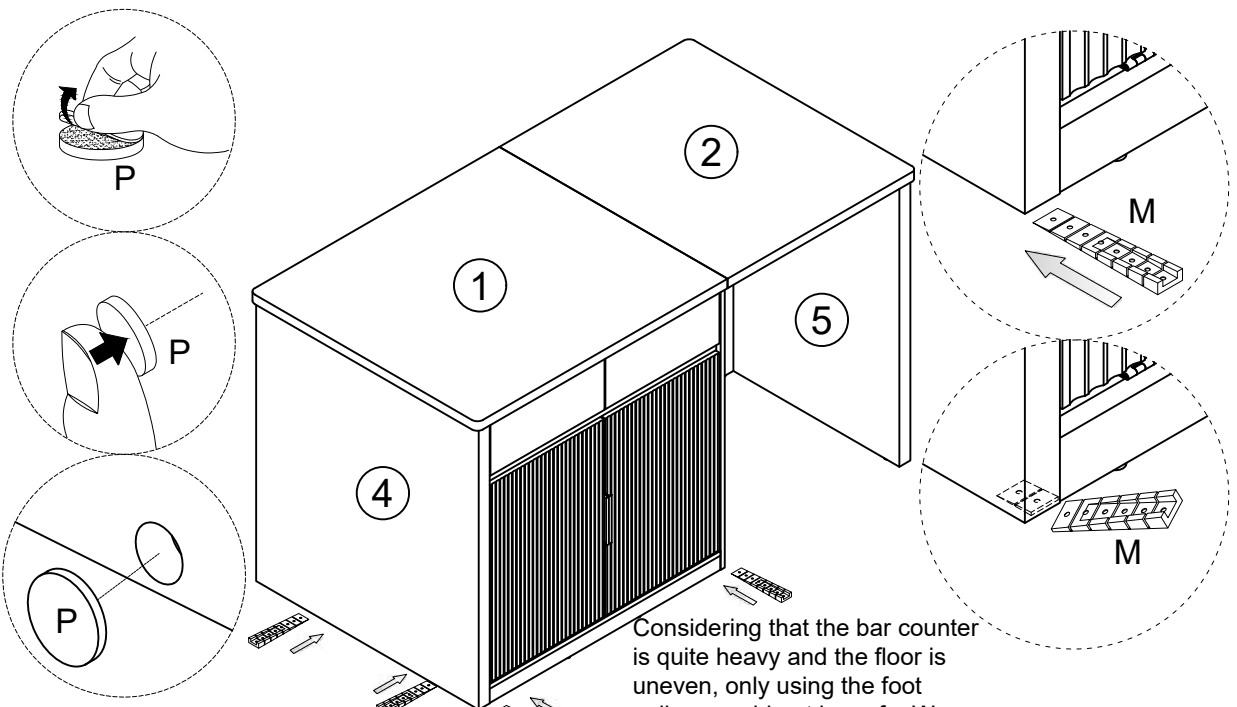

Exposed holes can be attached with ickers **P**

Considering that the bar counter is quite heavy and the floor is uneven, only using the foot spikes would not be safe. We have another option of using spacer **M**, which can be used following the method shown.

(Optional)

Install Spacer **M*6** to the assembled unit as shown if needed. We provide round Stickers **P*36**. You can stick it to cover the exposed nuts or holes so as to look nicer.

