

Assembly Instructions

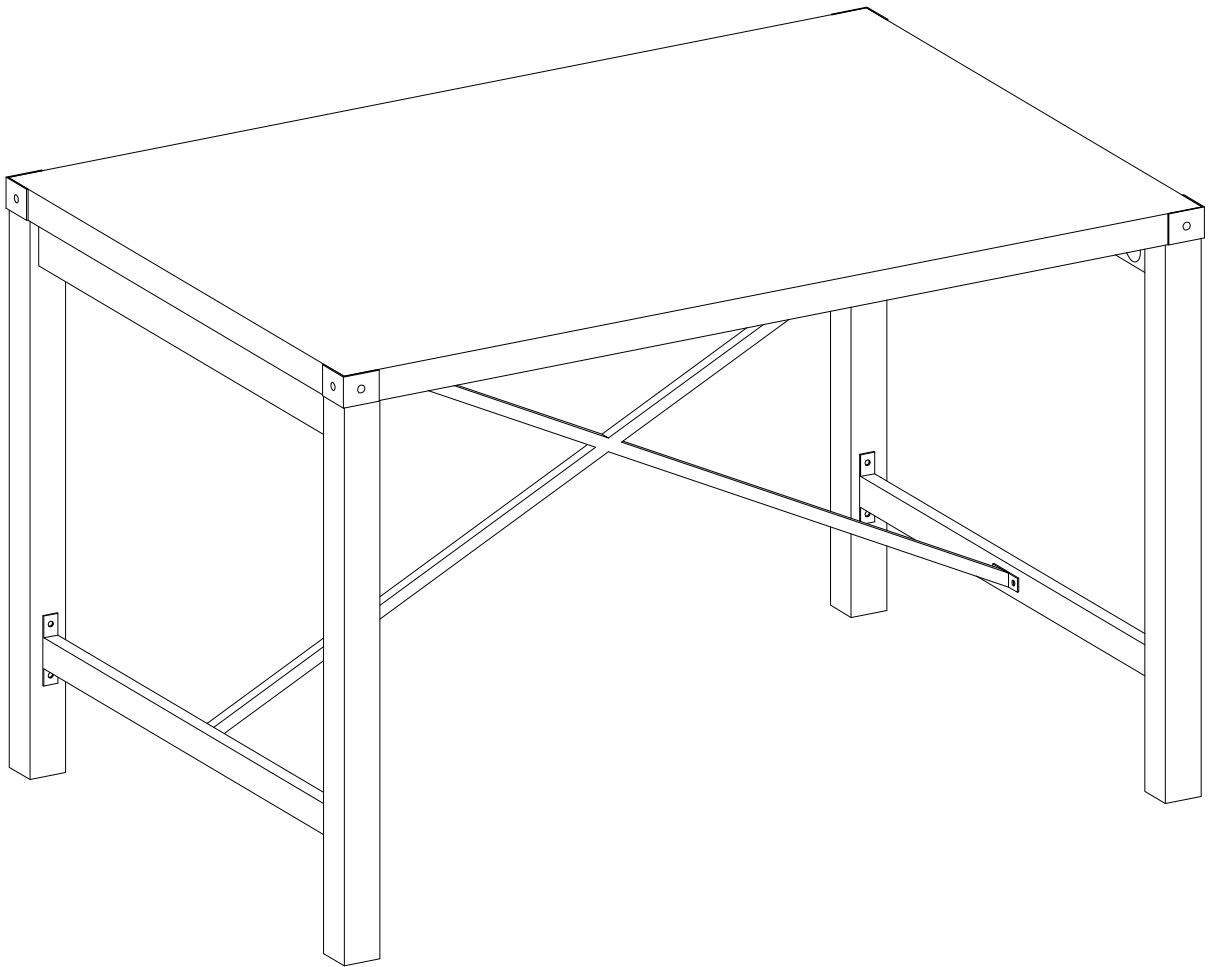

Revised 09/11/2018

General Assembly Guidelines

- I. Ensure that all parts and hardware are available before beginning assembly.
- II. Follow each step carefully to ensure the proper assembly of this product.
- III. Two people are recommended for ease in the assembly of this product.
- IV. The three main types of hardware used to assemble this product are : wood dowels , screws and bolts.
- V. The provided glue is to secure wood dowels in place . When first inserting dowels , locate the appropriate hole for the dowel , place a small amount of glue in the hole and insert the dowel . Wipe away excess glue immediately.

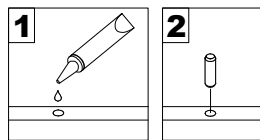

In future assembly steps when dowels are necessary to attach assembly parts together , place a small amount of glue on the end of the dowel before attaching parts together . Wipe away excess glue immediately.

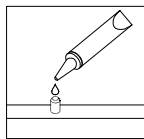

- VI. A Phillips head screwdriver is required for the assembly of this product .

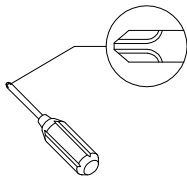



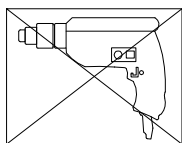



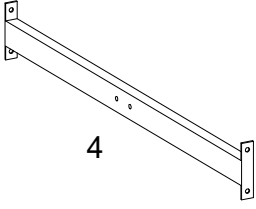
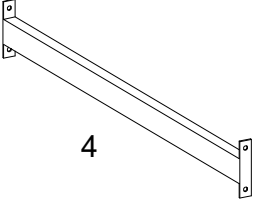
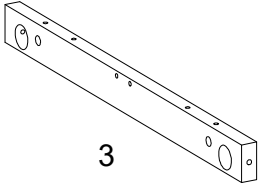
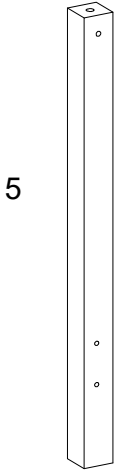
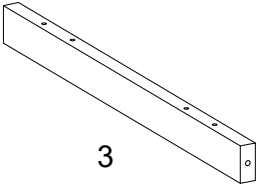
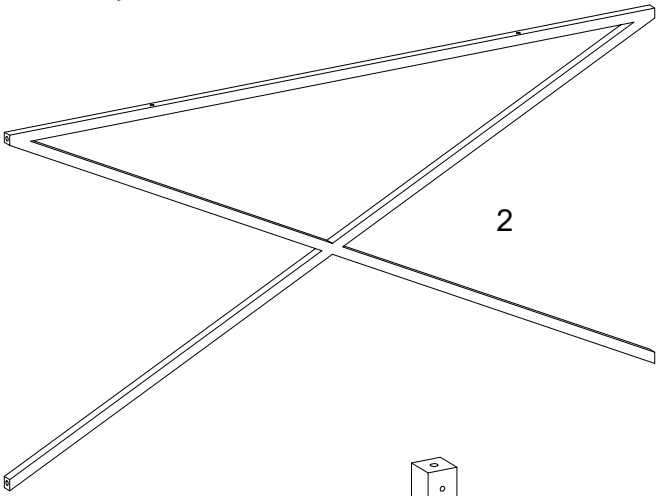
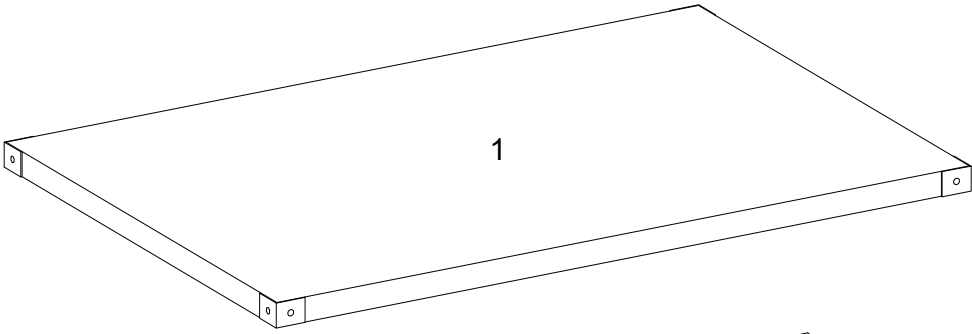





- VII. Power tools should not be used to assemble this product .

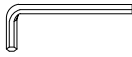

Parts List

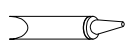

Hardware List

A		Ø8x30mm	Wooden dowel	8 pcs
B		Ø8x35mm	Cam bolt	4 pcs
C		Ø15x11mm	Cam lock	4 pcs
D		Ø30mm	Sticker	4 pcs
E		M6x25mm	Bolt	10 pcs
F		M 4	Hex Key	1 pc
G		M8	Half moon washer	4 pcs
H		M8	Bolt	4 pcs
J		M8	Nut	4 pcs
K		Ø38mm	Plastic cover	4 pcs
L		M8	Wrench	1 pcs
M		M6x12mm	Bolt	12 pcs
N			Plate	4 pcs
P			Bolt tube	1 pc

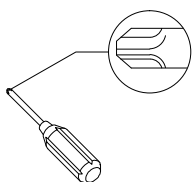

Philips head screwdriver required for assembly
(not included)

*The hardware quantities listed above are required for proper assembly.
Some extra hardware may also have been included.*

Step 1

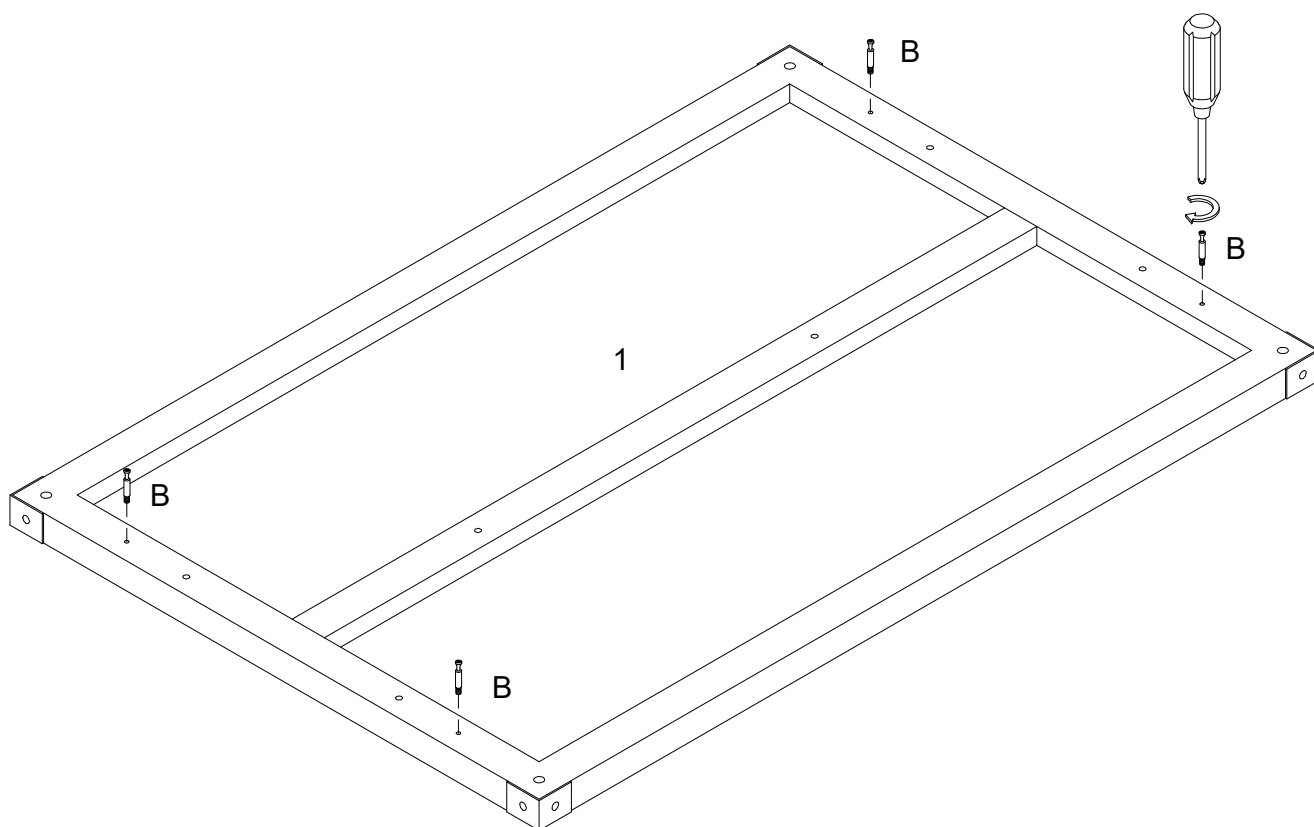

Use screwdriver secure cam bolt (B) into part(1).

Step 2

x 2

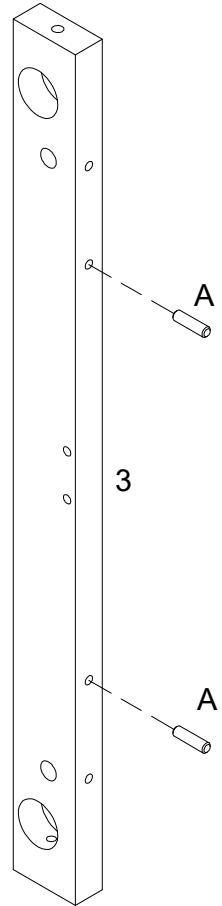
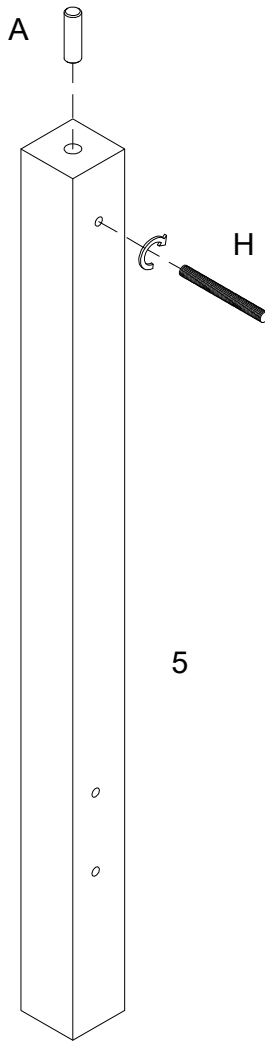
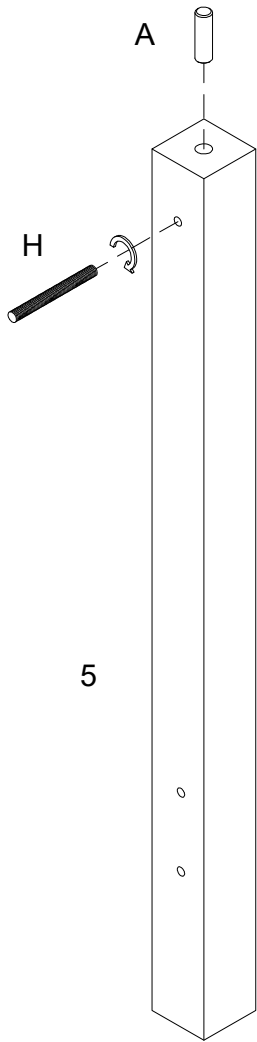

Insert wooden dowel (A) ,bolt (H) into part(3,5).

Step 3

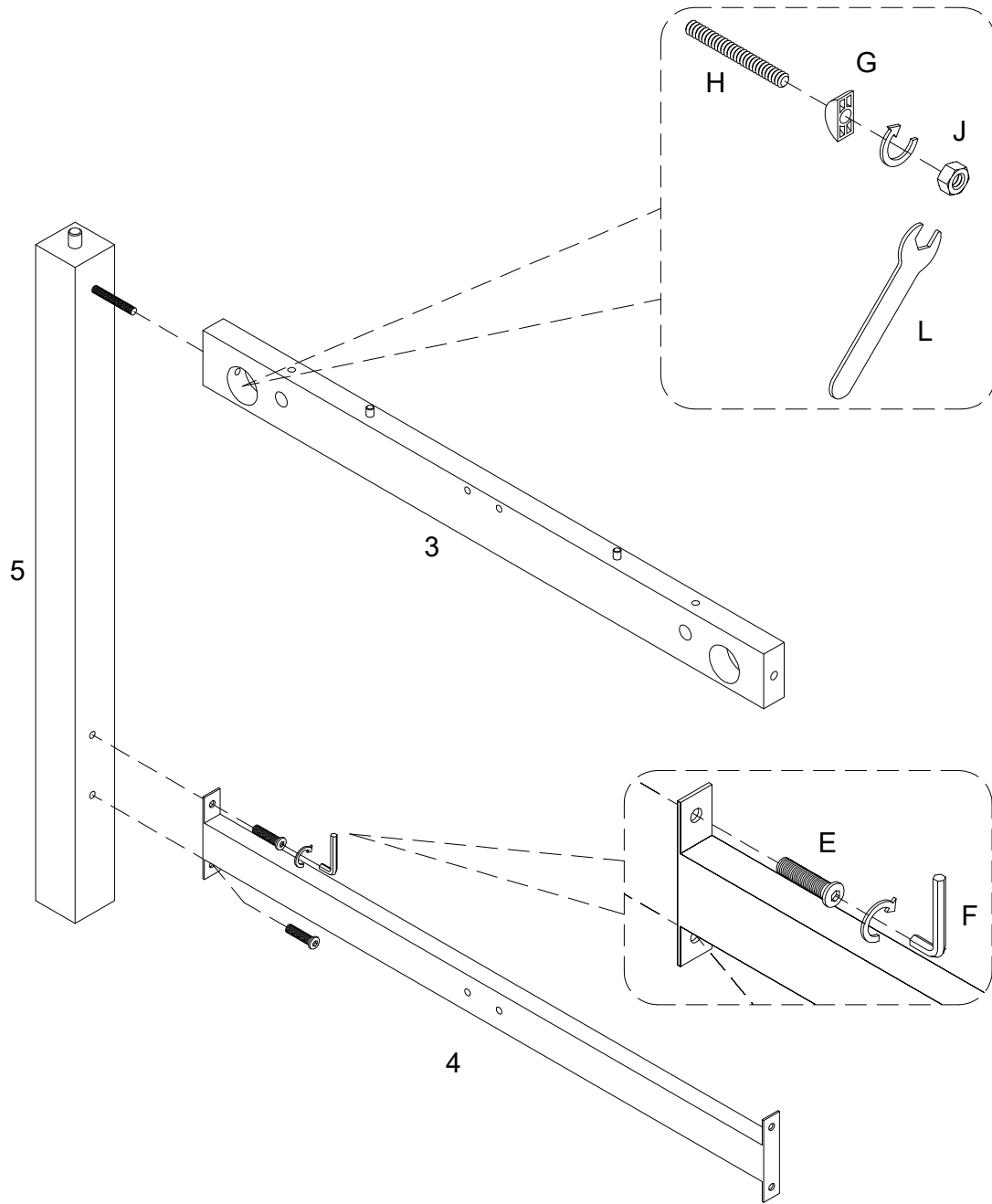

Use hex key (F) ,bolt (E) part (3,4) and attach to part (5)

Step 4

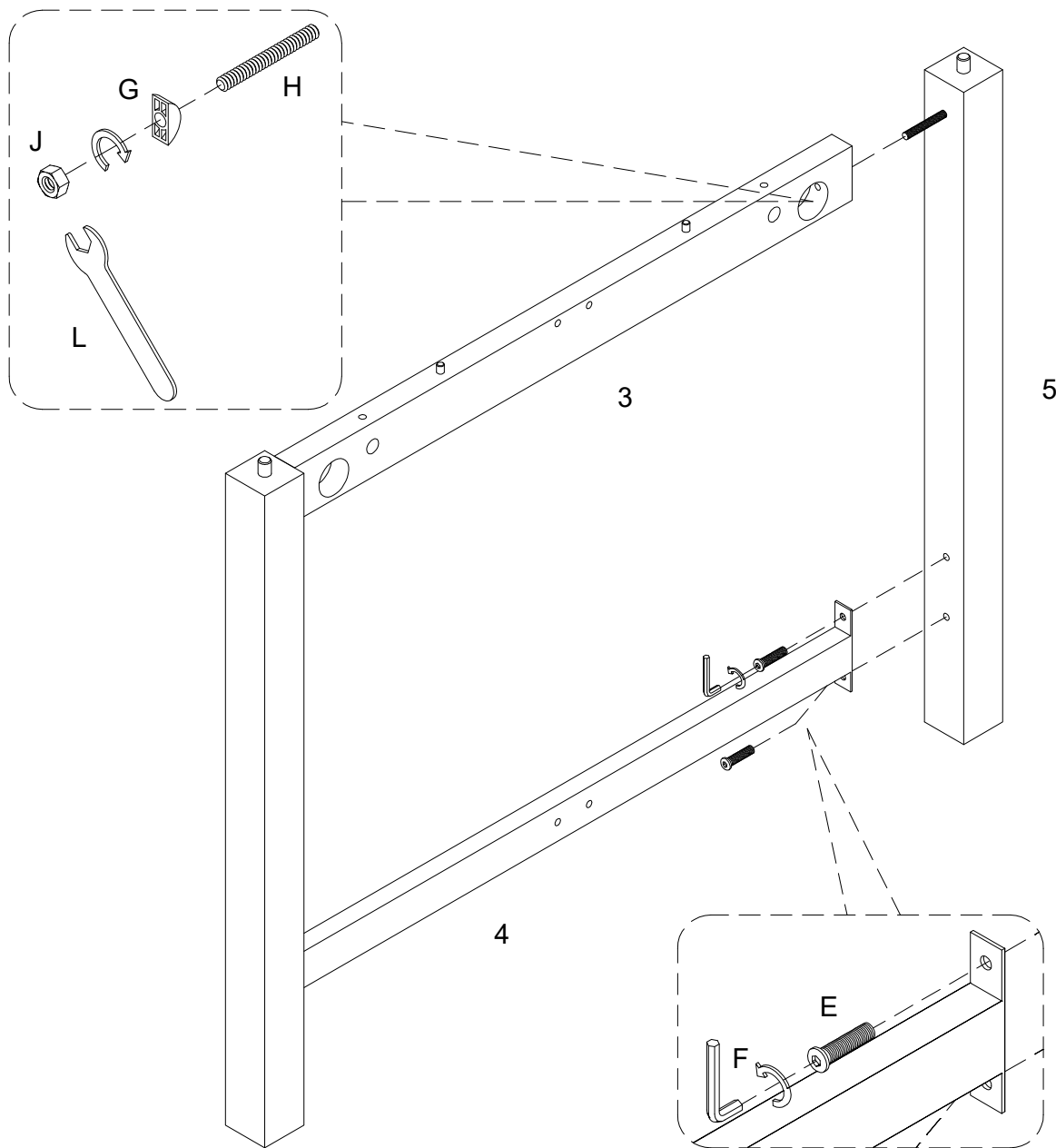

Use Half moon washer(G), wrench(L) , bolt (H), Nut(J) to attach part(3,4) to part(5).

Step 5

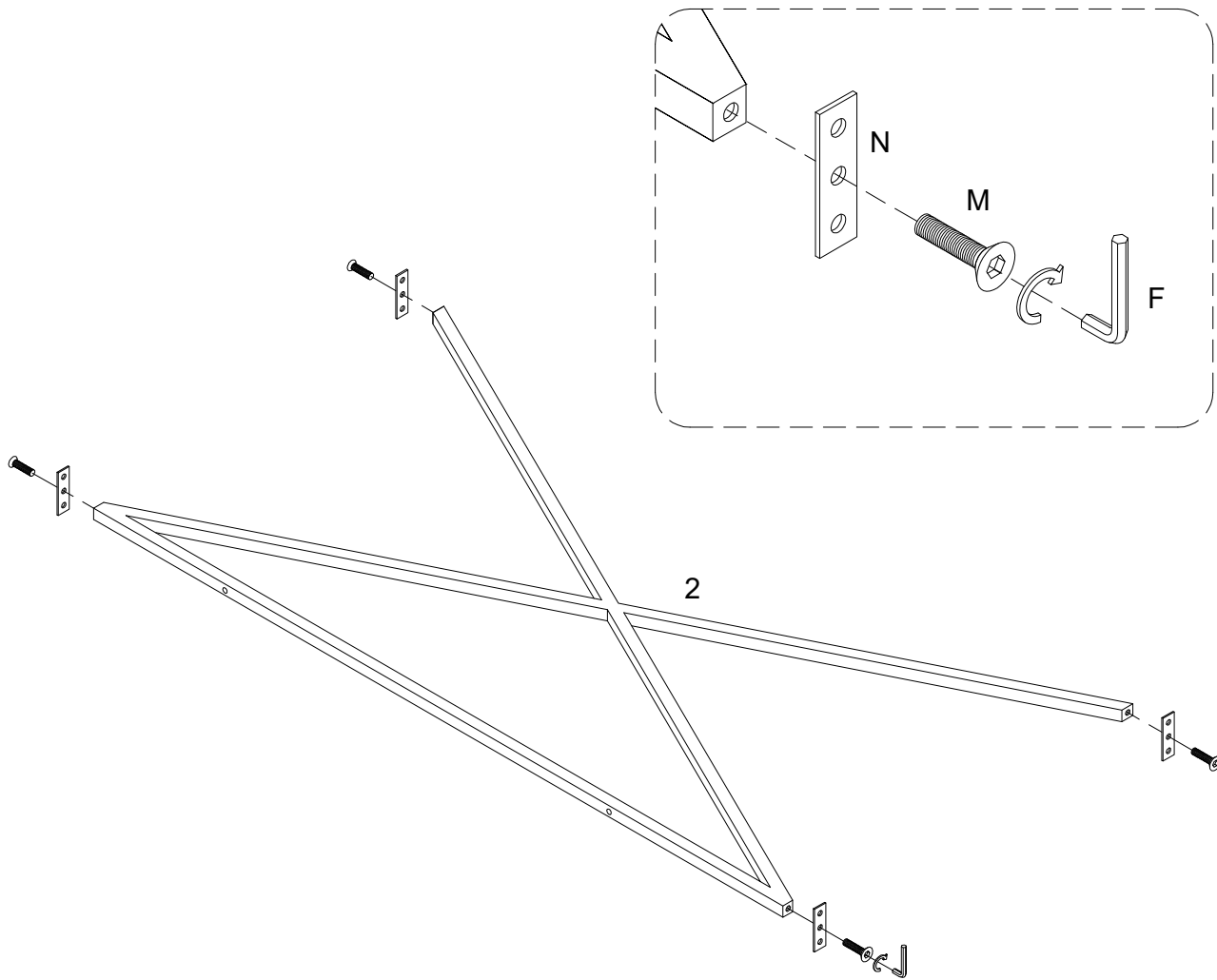

Use hex key (F) insert bolt (M),plate (N) into four sides of part(2)

Step 6

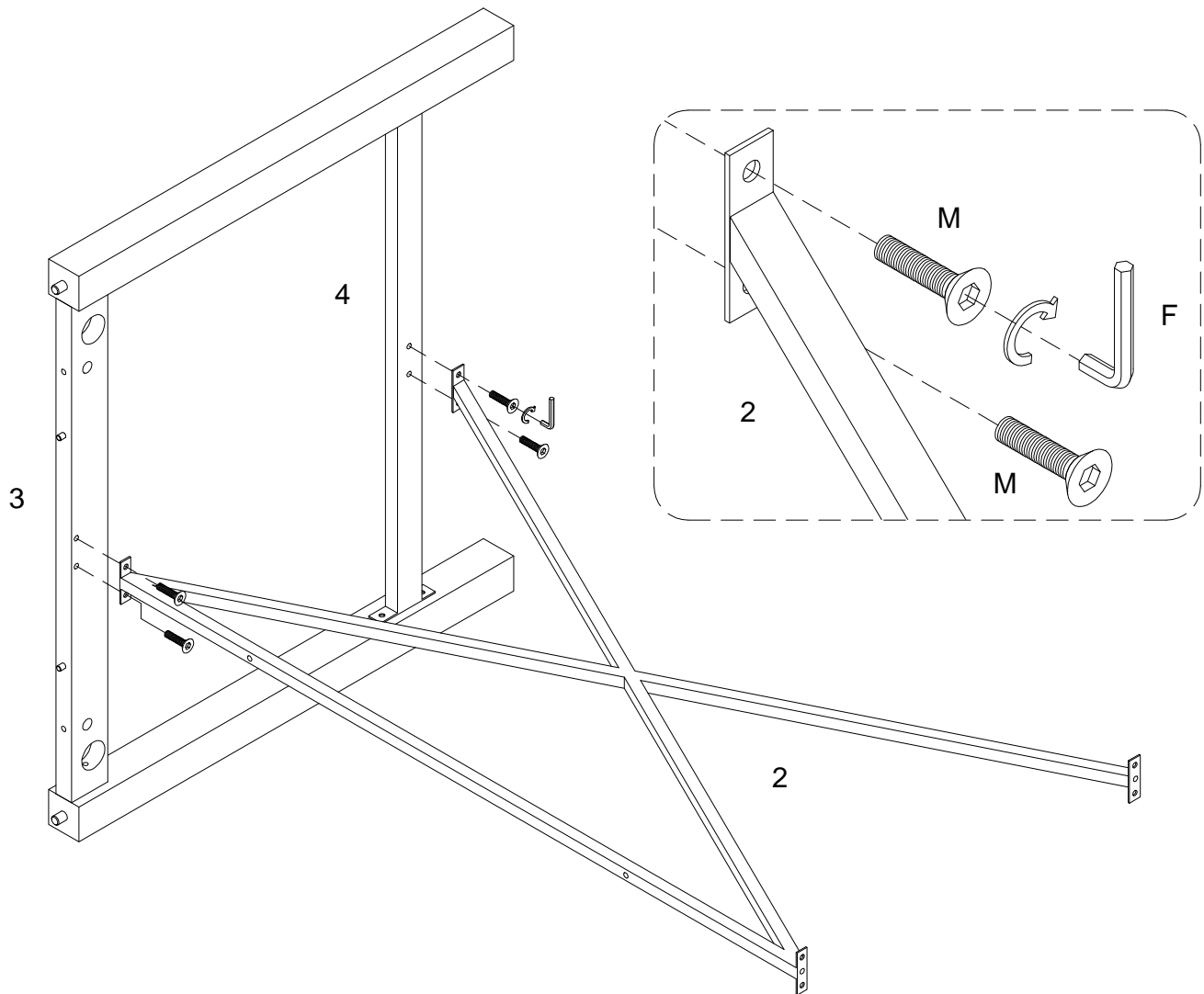

Use hex key (F) secure bolt (M) attach to part (2,3,4).

Step 7

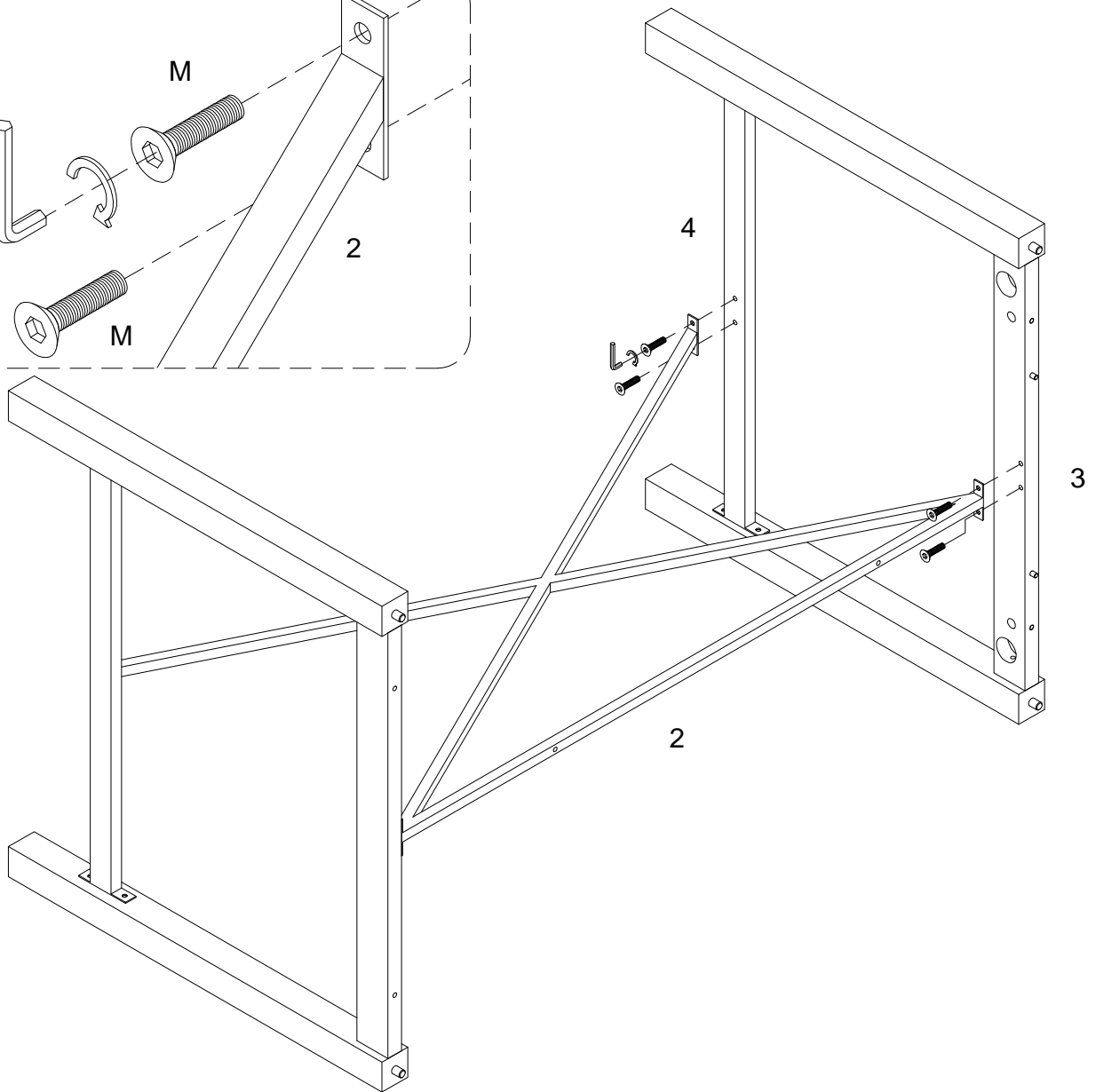
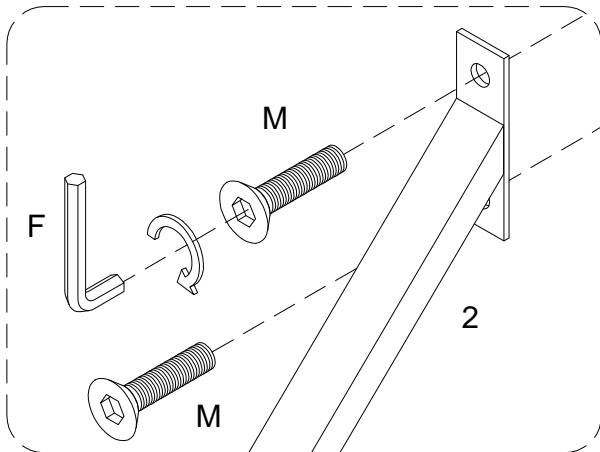

Use hex key (F) secure bolt (M) attach to part (2,3,4).

Step 8

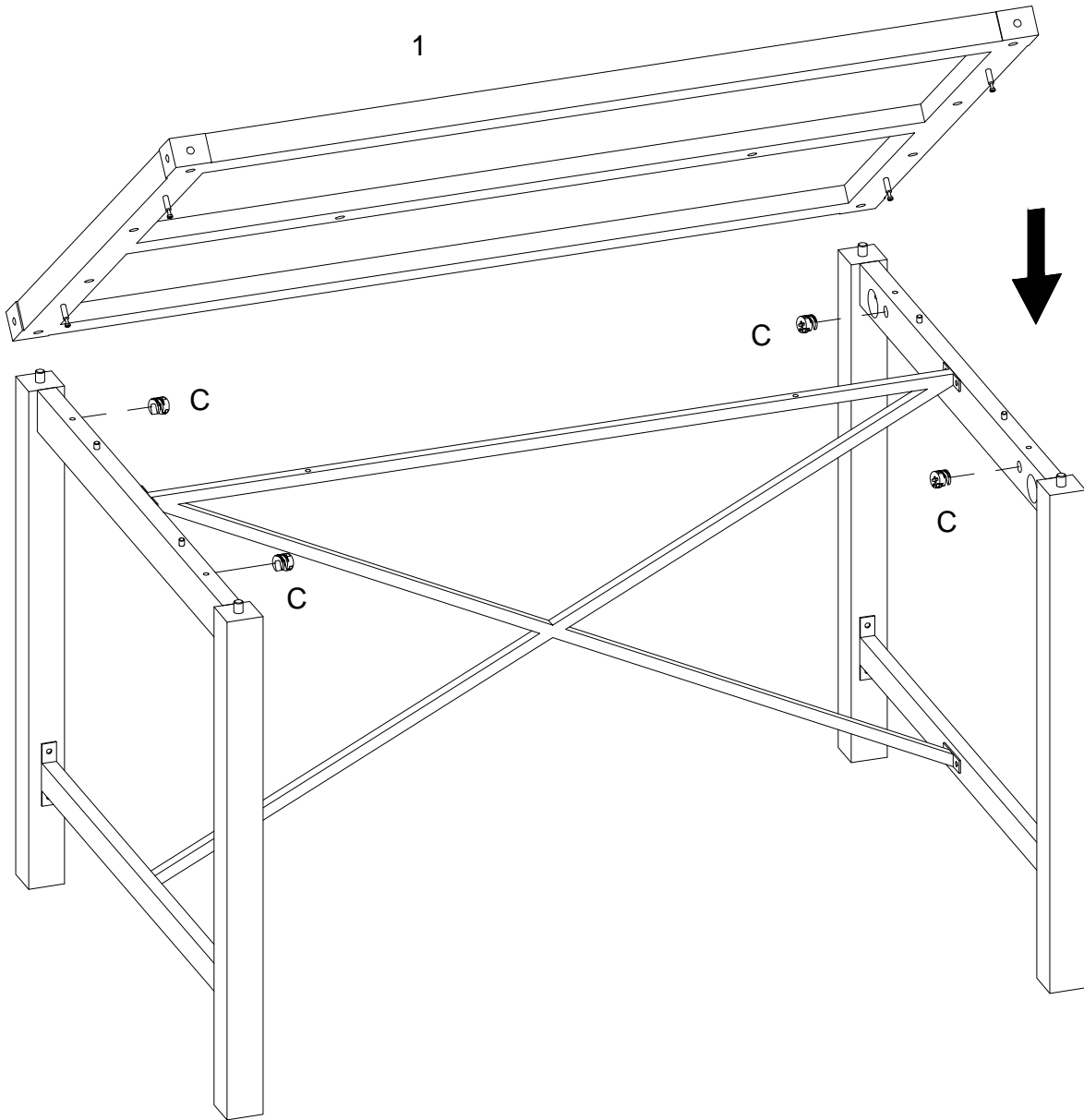
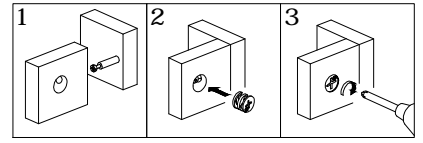

Insert part(1) to part (3, 4) and then insert cam lock (C) as per diagram,

Step 9

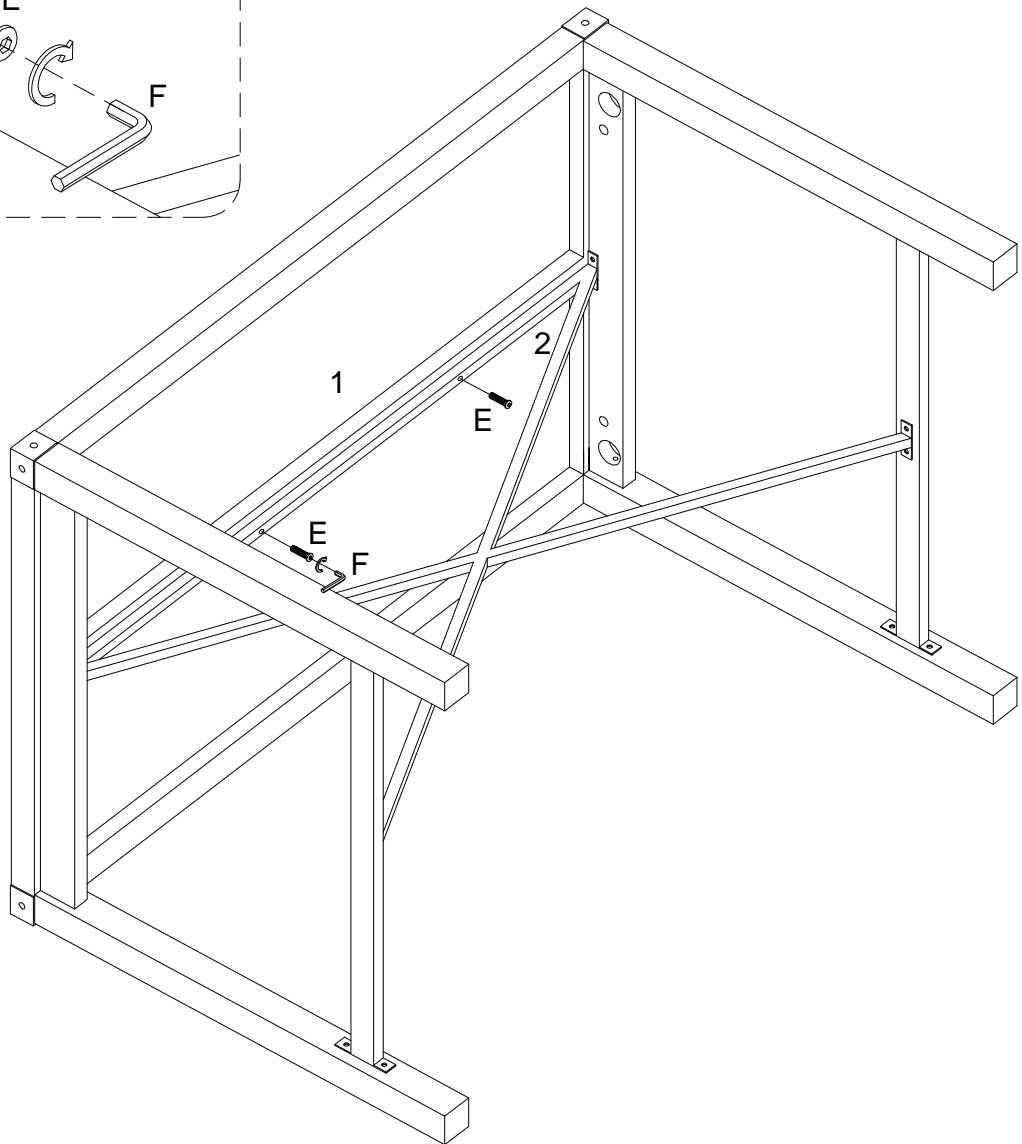
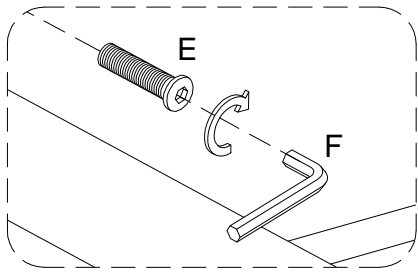

Use hex key (F) to secure bolt (E) into part (1).

Step 10

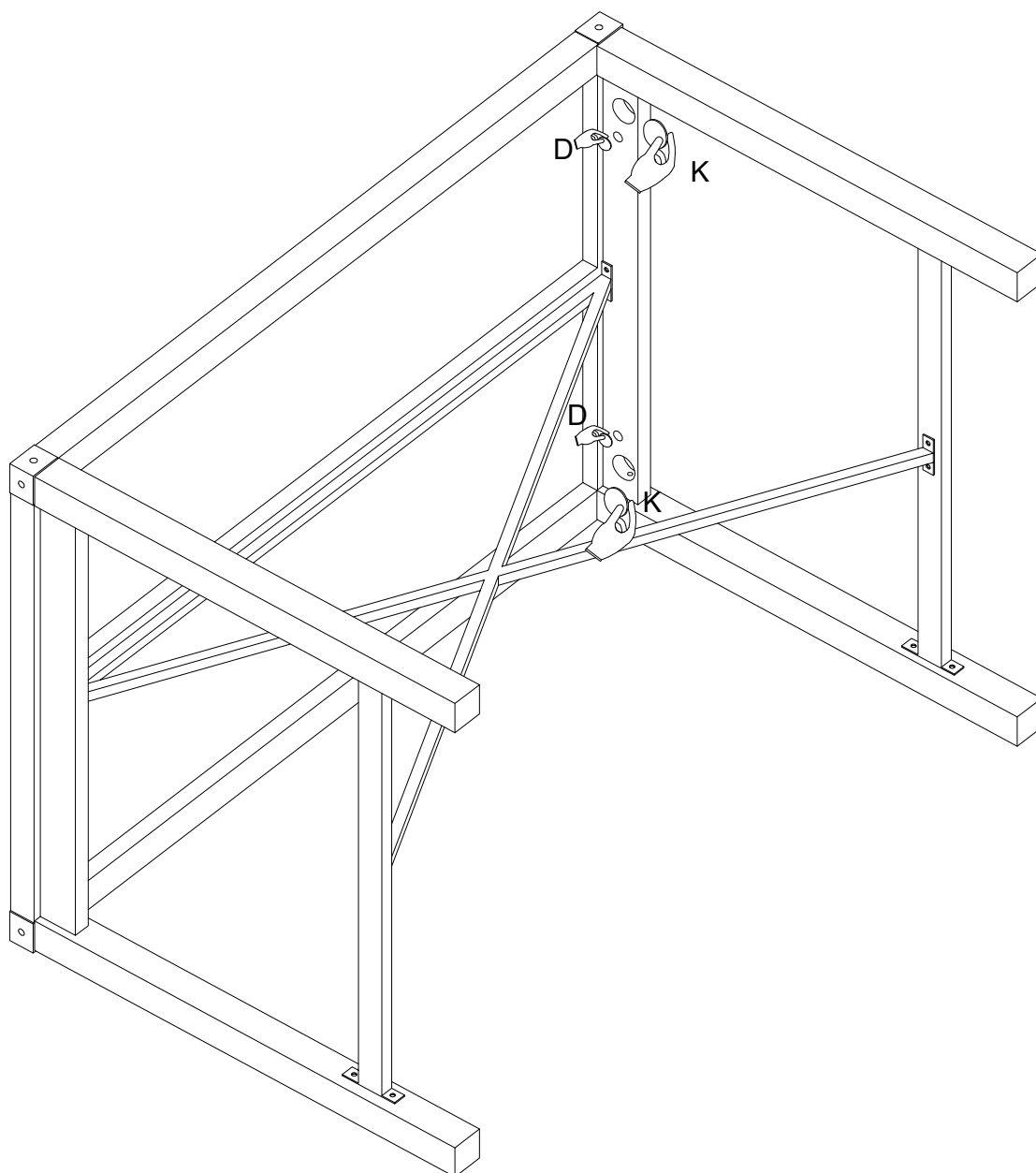

Place sticker (D,K) as per diagram.

Step 11

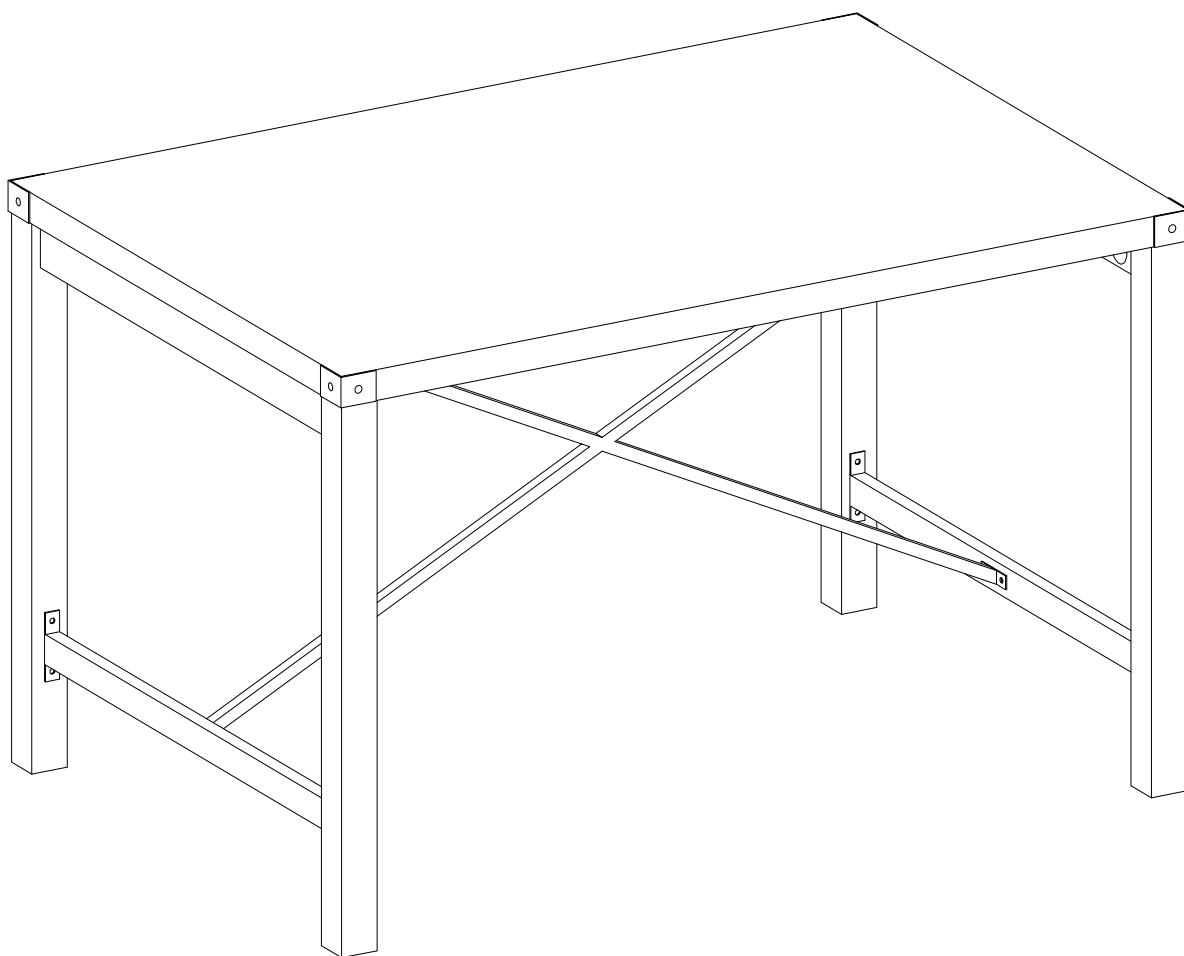

Final Assembly