

# Commercial Cart

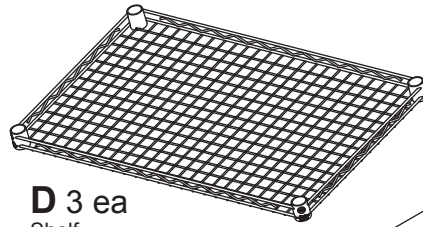
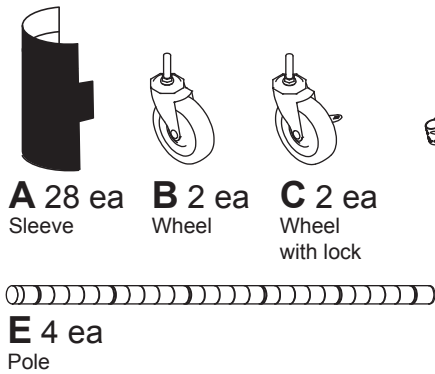

**Assembly Time:**  
Less than 30 minutes.

This product's intended use is for dry storage and heated environments in a home or commercial setting. The shelf capacity is 200 lbs. when weight is evenly distributed.

**Tools Needed:**  
No additional tools required.

**STEP 1.** Starting at the bottom of each pole (E), snap two sleeves (A) onto poles at desired intervals. The sleeves are marked with a directional arrow to show proper placement. Use grooves on poles to ensure even shelf placement among the four poles.

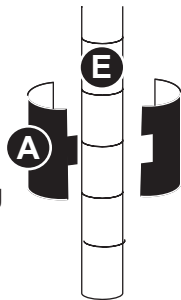

**NOTE:** The bottom of the pole (E) is the end with the small threaded hole for the wheel.

**NOTE:** Place only enough sleeves to assemble bottom shelf. This step will be repeated for each additional shelf and handle.

**STEP 3.** Repeating step 1, put two more sets of sleeves (A) where you want the handle (F). Slide handle (F) over poles to rest on the sleeves. Repeat steps 1 and 2 for the top shelf. Insert the wheels (B&C) and tighten with provided wrench (G). Enjoy your Commercial Cart.

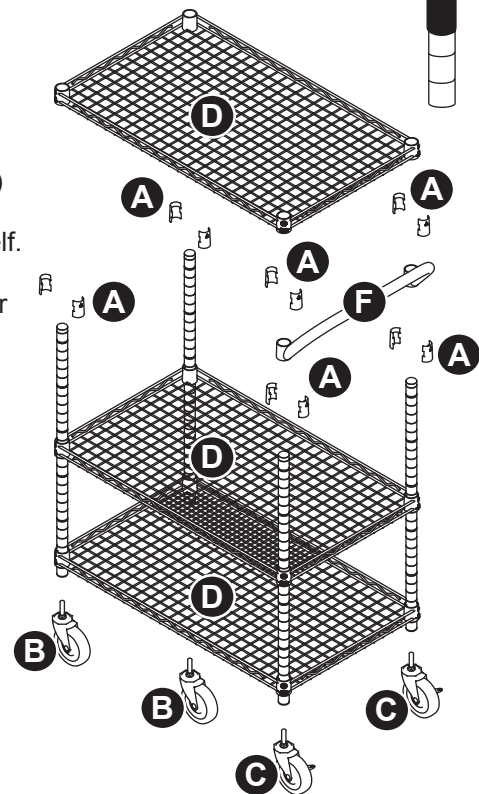
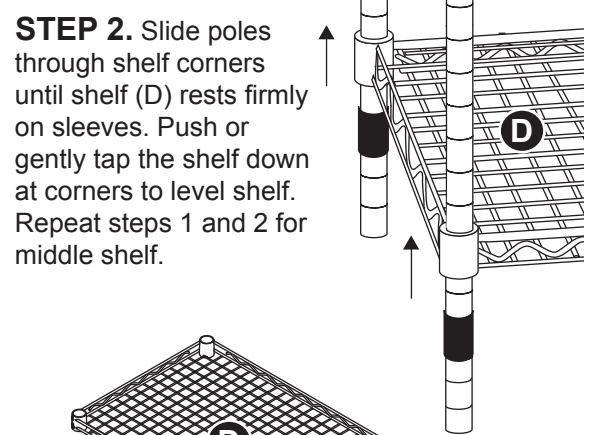

MADE IN CHINA

**NEED HELP?** For help with assembly, or if you are missing a part, please call our Customer Service Department

Printed in China

## TEN YEAR LIMITED WARRANTY

All our wire products distributed by the Company are warranted to the original purchaser at the time of purchase and for ten (10) years after the purchase date ("warranty term"). The Company warrants to you, the original purchaser, that our wire products and all metal or plastic parts and components are free of defects in material or workmanship during the warranty term. The word "defects" as used in this limited warranty is defined as any imperfections which impair the use of the wire product. This limited warranty is expressly limited to the replacement or repair of metal or plastic parts and components (in the Company's discretion) and the Company will have a reasonable amount of time to remedy said defect. This limited warranty only applies under conditions of normal use. This limited warranty does not cover defects caused by improper assembly or disassembly, defects occurring after purchase due to intentional damage, product modifications, exposure to the elements (including, but not limited to, wet environments), accidents, misuse, abuse or negligence and labor or assembly costs.

THE COMPANY DISCLAIMS ALL OTHER WARRANTIES EXPRESS OR IMPLIED INCLUDING, WITHOUT LIMITATION, ANY IMPLIED WARRANTIES OF MERCHANTABILITY OR FITNESS FOR A PARTICULAR PURPOSE, EXCEPT TO THE EXTENT THAT ANY WARRANTIES IMPLIED BY LAW CANNOT BE VALIDLY WAIVED. NO ORAL OR WRITTEN INFORMATION OR ADVICE GIVEN BY THE COMPANY, ITS DISTRIBUTORS, DEALERS, AGENTS OR EMPLOYEES, SHALL CREATE ANOTHER WARRANTY OR MODIFY THIS LIMITED WARRANTY. THIS LIMITED WARRANTY STATES THE COMPANY'S ENTIRE LIABILITY AND YOUR EXCLUSIVE REMEDY AGAINST THE COMPANY FOR ANY FAILURE OF THE WIRE PRODUCT TO OPERATE PROPERLY. NEITHER THE COMPANY NOR ANYONE ELSE INVOLVED IN THE DEVELOPMENT, PRODUCTION, OR DELIVERY OF THIS WIRE PRODUCT SHALL BE LIABLE FOR ANY INDIRECT, INCIDENTAL, SPECIAL, CONSEQUENTIAL, EXEMPLARY, OR PUNITIVE DAMAGES, INCLUDING LOST PROFITS, ARISING FROM THE USE OF OR INABILITY TO USE THE PRODUCT, EVEN IF ADVISED OF THE POSSIBILITY OF SUCH DAMAGES. SOME STATES DO NOT ALLOW THE EXCLUSION OR LIMITATION OF INCIDENTAL OR CONSEQUENTIAL DAMAGES, SO THE ABOVE LIMITATION OR EXCLUSION MAY NOT APPLY TO YOU. This Warranty gives you specific legal rights and you may also have other rights, which vary from State to State.

The Limited Warranty set forth above is provided on products purchased in and used in the United States, and is only in effect with valid proof of purchase (bill of sale) presented or shipped (shipping cost prepaid) to the Company within the United States.