

ASSEMBLY INSTRUCTIONS & PARTS IDENTIFICATION

Hardware Kit			
Ltr	Qty	Description	Size
A	1 pc	Allen wrench	4mm
B	8 pcs	Bolt	1/4"Dia*2"
C	8 pcs	Lock washer	1/4"Dia
D	8 pcs	Flat washer	1/4"Dia*3/4"
E	4 pcs	Screw	#8*1-1/2"

Part List			
No.	Parts	Description	Qty
①	1032-3P02	Leg	4 pcs
②	1032-3P08	Shelf	1 pc
③	1032-3P51	Storage Box	1 pc
④	1032-3P05	Drawer	1 pc
⑤	1032P01F	Floor Glide	4 pcs
⑥	1032P04	Knob/Screw	1 set
⑦	1032P05A	Drawer Stopper	1 pc
⑧	1032-3P06	Drawer Glide	1 pc
⑨	1032P05D	Drawer Support	1 pc



STEP 1: ▼

First pull out the drawer, remove the drawer by pushing down on the plastic drawer stop and gently pulling out the drawer.

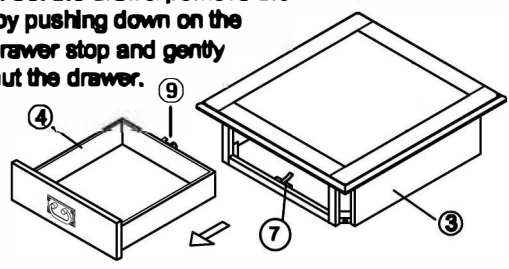

STEP 2: ▼

Carefully place the table top upside-down on a smooth, flat surface to prevent scratches during assembly. Attach three legs to the table top with Allen bolt (B), Lock washer (C) and Flat washer (D), loosely tightening with the provided Allen wrench (A). Do not completely tighten bolts at this point.

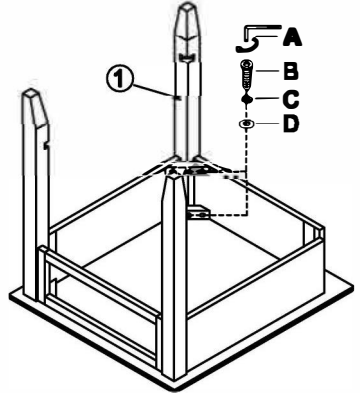

STEP 3: ▼

Insert the shelf between the three legs. Add the fourth leg and secure with a bolt, lock washer and a flat washer. Secure the shelf to the legs using screws (E). Once the shelf is in place, fully tighten all bolts and screws.

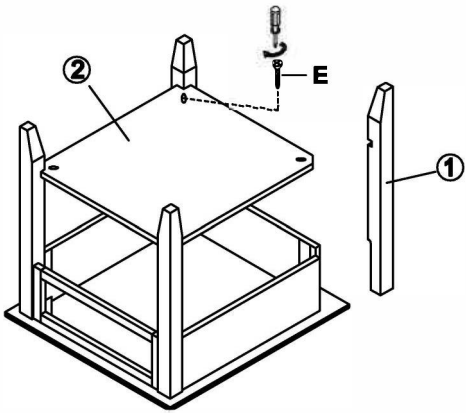

STEP 4: ▼

Carefully turn the assembled table to the upright position. Put back the drawer. Assembly is now complete.

