

# *ASSEMBLY INSTRUCTIONS*



**TV CONSOLE**

# ASSEMBLY INSTRUCTIONS

## ASSEMBLY TIPS:

1. Remove hardware from box and sort by size.
2. Please check to see that all hardware and parts are present prior to start of assembly.
3. Please follow attached instructions in the same sequence as numbered to assure fast & easy assembly.



### WARNING!

1. Don't attempt to repair or modify parts that are broken or defective. Please contact the store immediately.
2. This product is for home use only and not intended for commercial establishments.



ASSEMBLY TIME

50 MINUTES

MAX TV SIZE : 85"

## PARTS IDENTIFICATION

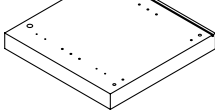
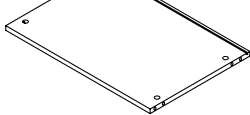
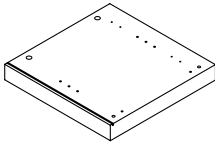
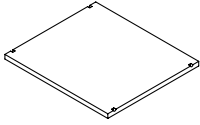
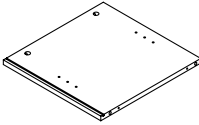
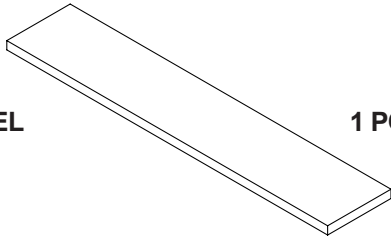
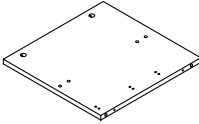
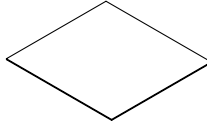
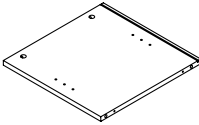
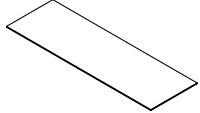
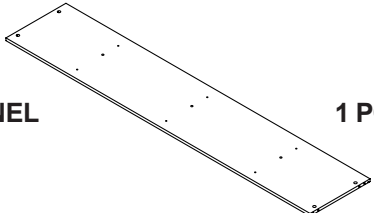
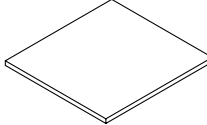
A	LEFT SIDE PANEL		1 PC	G	CROSS PANEL		2 PCS
B	RIGHT SIDE PANEL		1 PC	H	ADJUSTABLE SHELF		2 PCS
C	LEFT DIVIDER PANEL		1 PC	I	TOP PANEL		1 PC
D	MIDDLE DIVIDER PANEL		1 PC	J	BACK PANEL		2 PCS
E	RIGHT DIVIDER PANEL		1 PC	K	MIDDLE BACK PANEL		2 PCS
F	BOTTOM PANEL		1 PC	L	DOOR		2 PCS

### NOTE:

Phillips head screw driver is required in the assembly process; however, manufacturer does not provide this item.

M

LEFT DRAWER  
FRONT PANEL

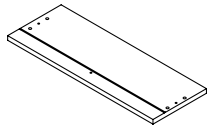

1 PC

N

RIGHT DRAWER  
FRONT PANEL

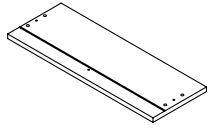

1 PC

O

DRAWER  
BACK PANEL

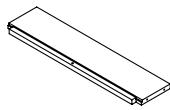

2 PCS

P

DRAWER LEFT  
SIDE PANEL

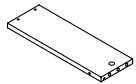

2 PCS

Q

DRAWER RIGHT  
SIDE PANEL

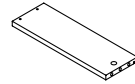

2 PCS

R

DRAWER  
BOTTOM PANEL

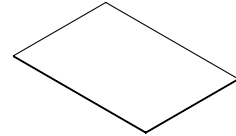

2 PCS

S

DRAWER  
BOTTOM  
SUPPORT

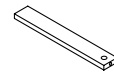











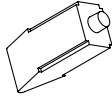
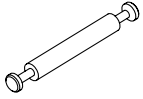
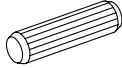
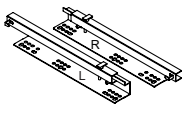
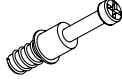

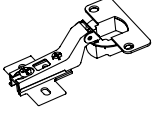
2 PCS

**NOTE:**

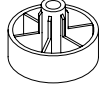
Phillips head screw driver is required in the assembly process; however, manufacturer does not provide this item.

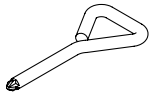
## HARDWARE IDENTIFICATION

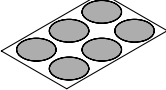
Z

NO	DESCRIPTION	FIGURE	Q'TY	NO	DESCRIPTION	FIGURE	Q'TY
1	GLUE 40g		1 PC	10	CAM BOLT Ø7x63mm SR		2 PCS
2	WOODEN DOWEL Ø8x30mm		32 PCS	11	GLIDES L=350mm SR		2 SET
3	CAM BOLT Ø7x35.5mm SR		24 PCS	12	GLIDES BOLT Ø6x13mm SR		24 PCS
4	CAM LOCK Ø15x12mm SR		28 PCS	13	HINGE Ø35mm SR		4 PCS
5	SCREW Ø4.5x42mm SR		6 PCS	14	HINGE SCREW Ø4x15mm SR		16 PCS
6	SCREW Ø4.5x42mm SR		10 PCS	15	FOOT Ø35xH19mm		3 PCS
7	PLASTIC FEET Ø15mm		4 PCS	16	SCREW DRIVER		1 PC
8	PIN FOR ADJUSTABLE SHELF Ø4.9x15mm SR		8 PCS	17	STICKER Ø20mm		5 PCS
9	WOODEN DOWEL Ø8x50mm		2 PCS				

Z11,Z13,Z15 not included in blister packaging.

**NOTE:**

Phillips head screw driver is required in the assembly process; however, manufacturer does not provide this item.

# STEP 1

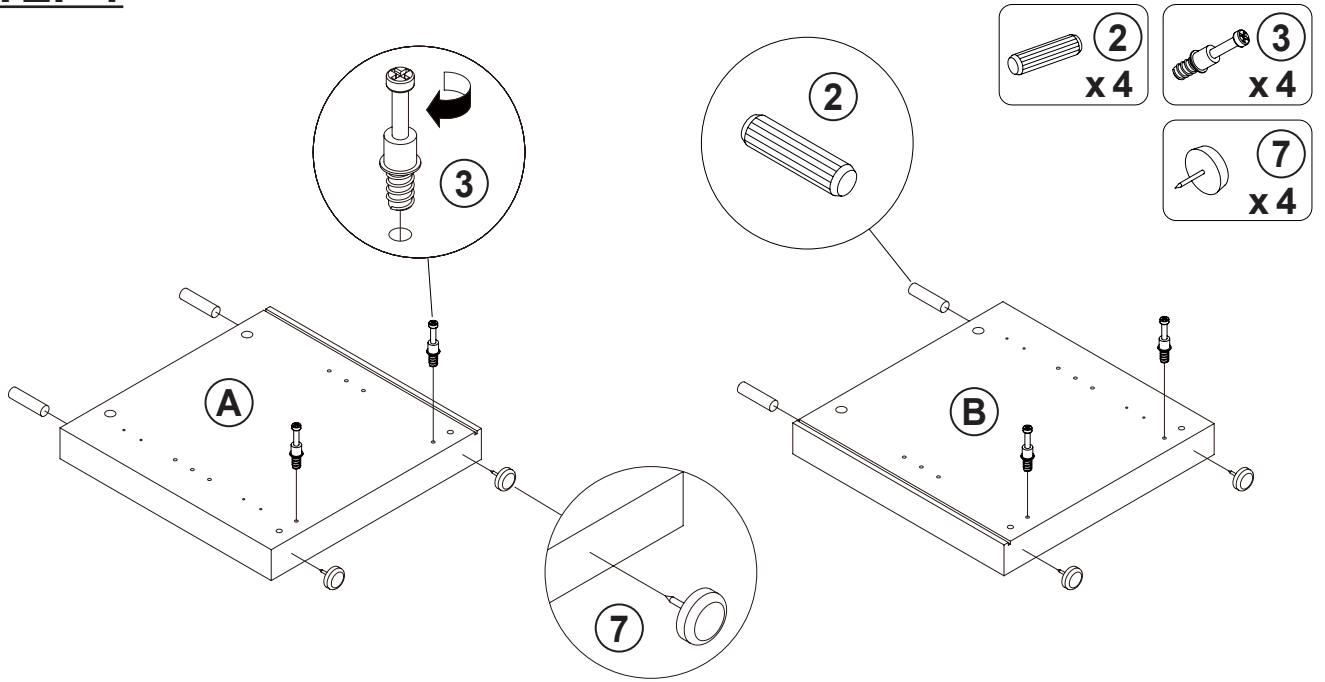

# STEP 2

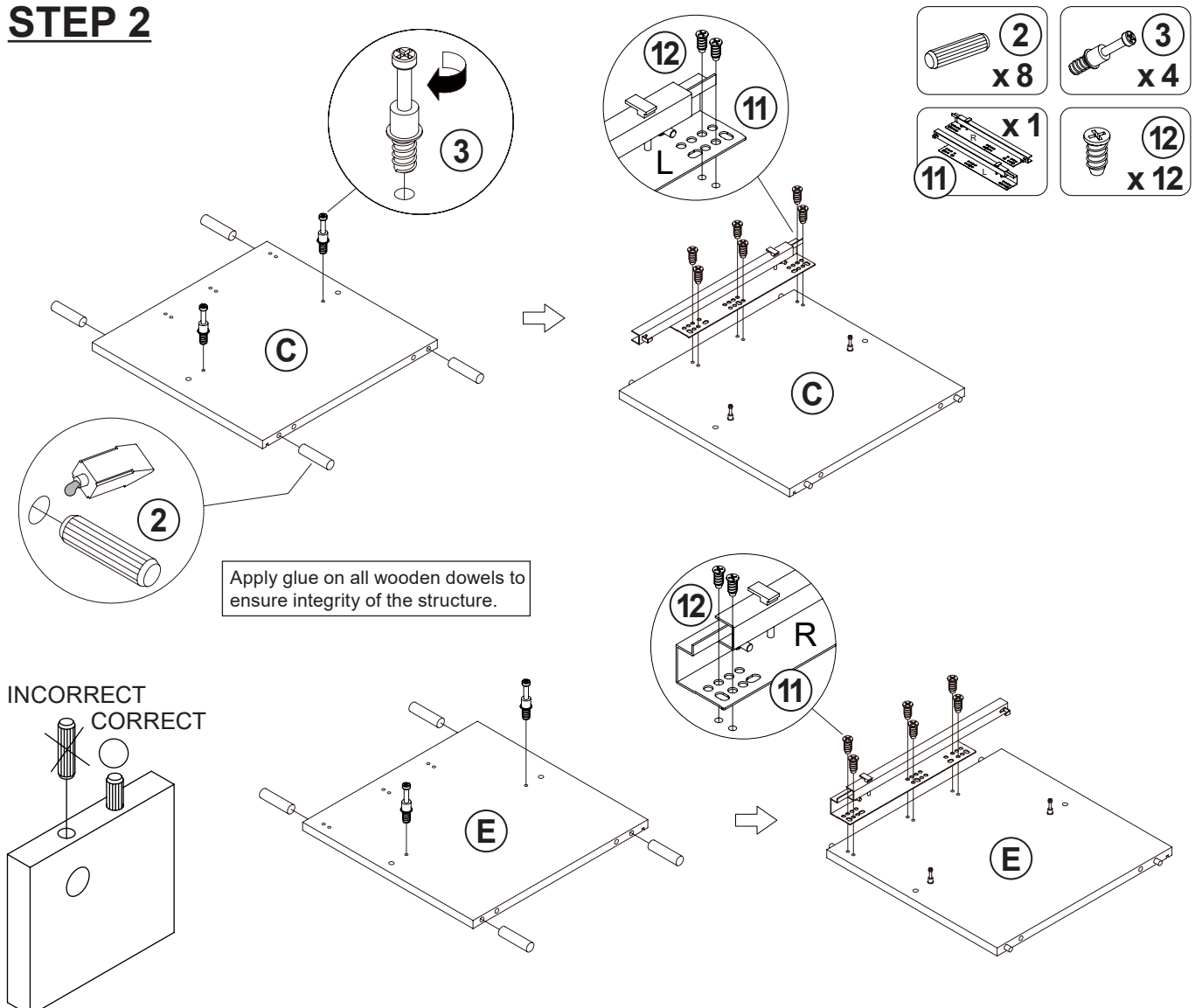

## STEP 3

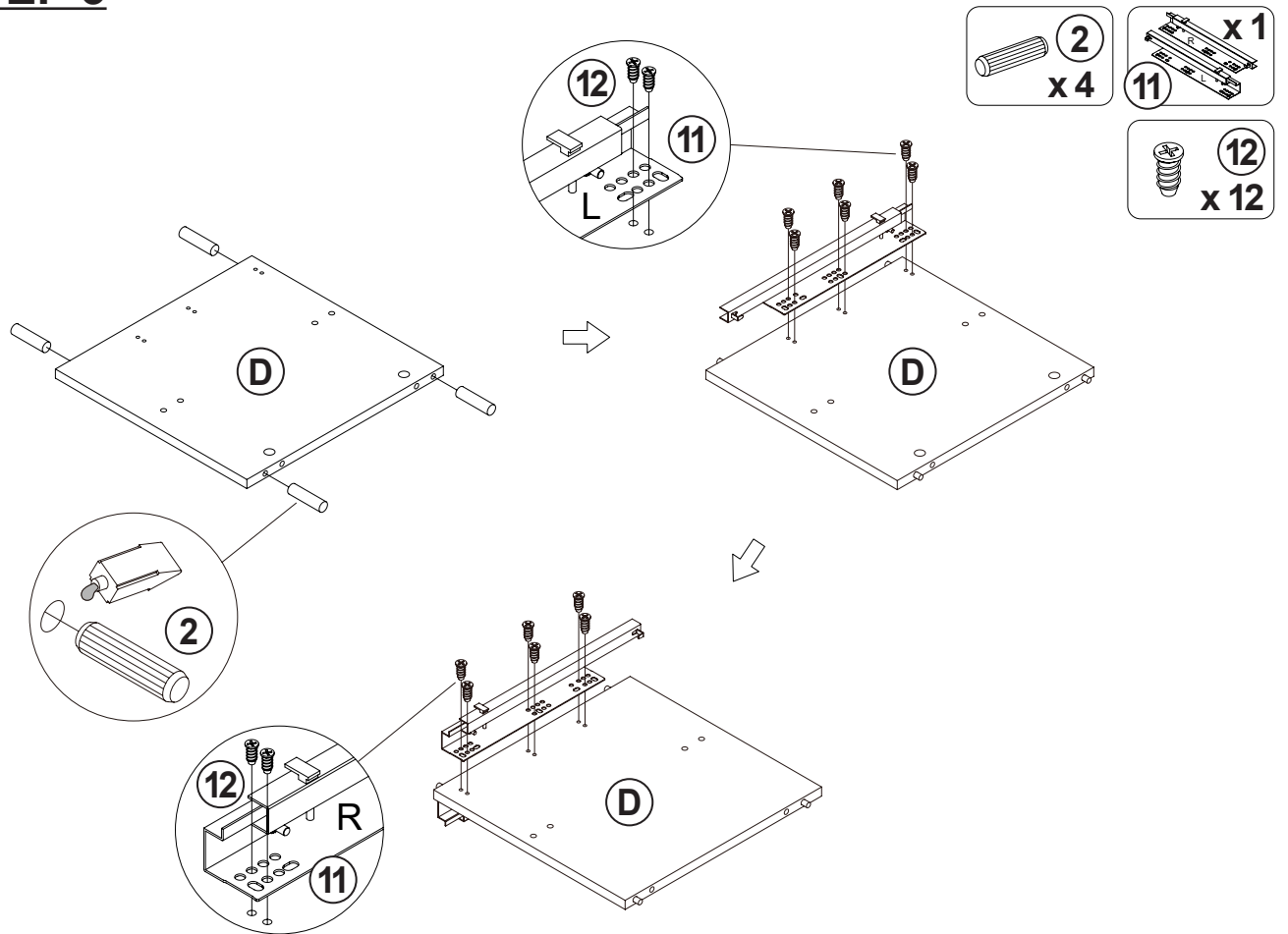

## STEP 4

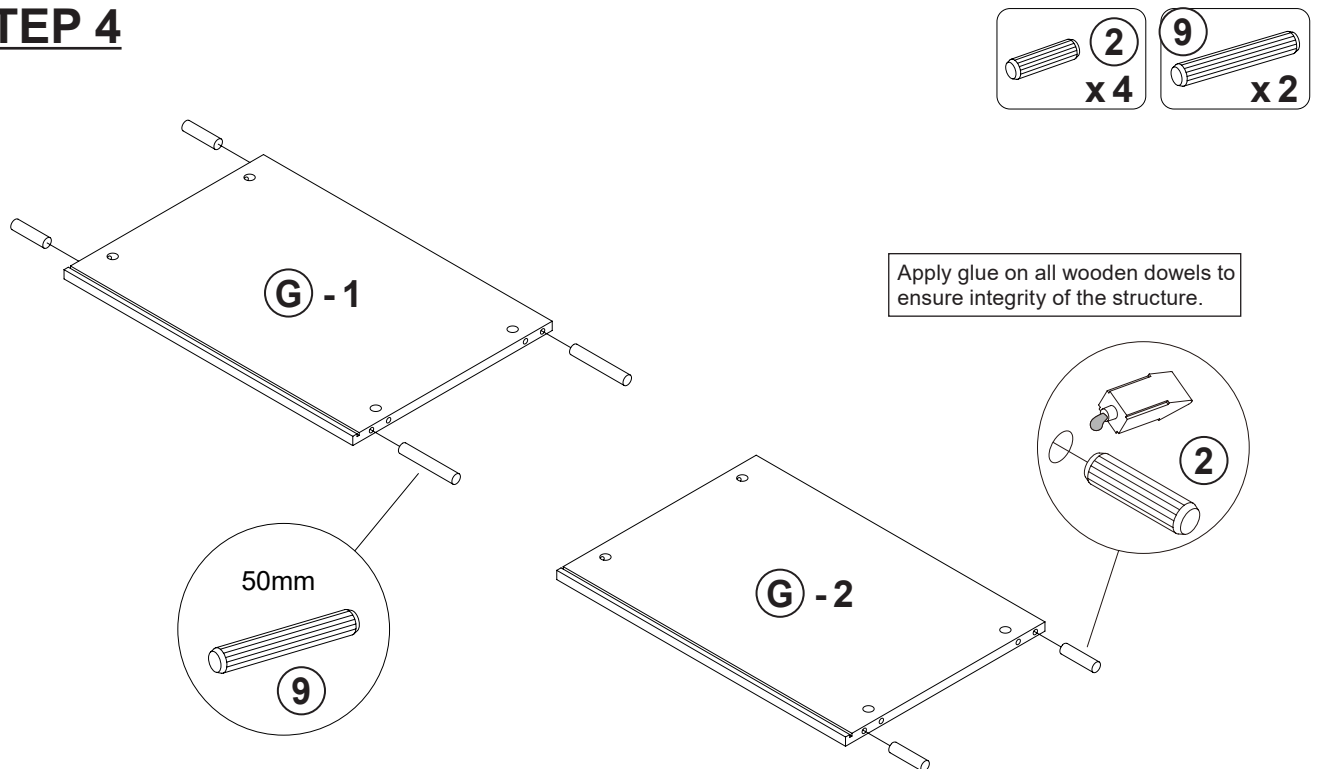

# STEP 5

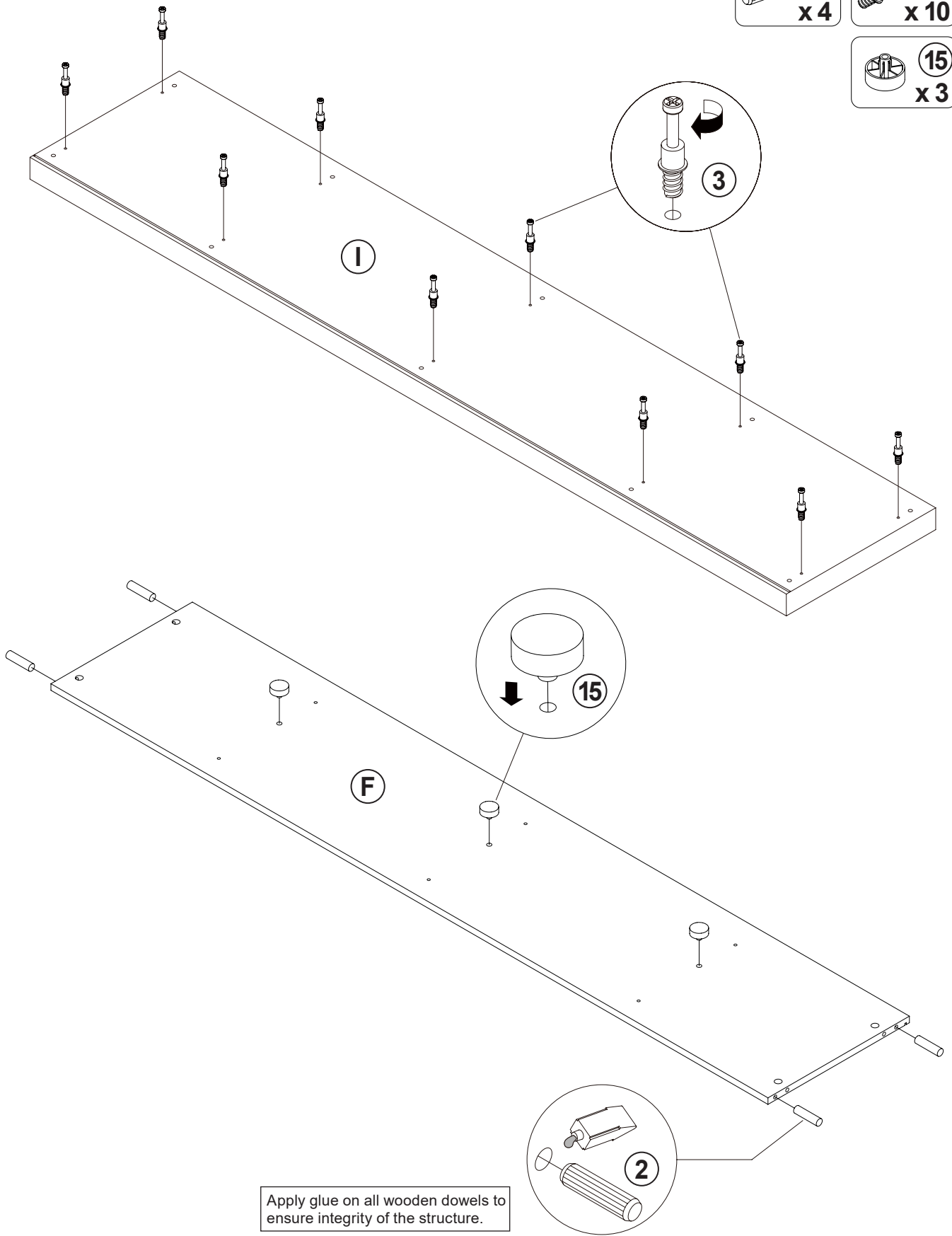
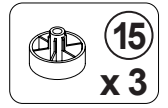
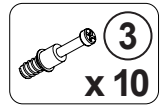
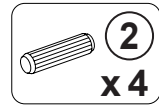

## STEP 6

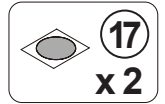
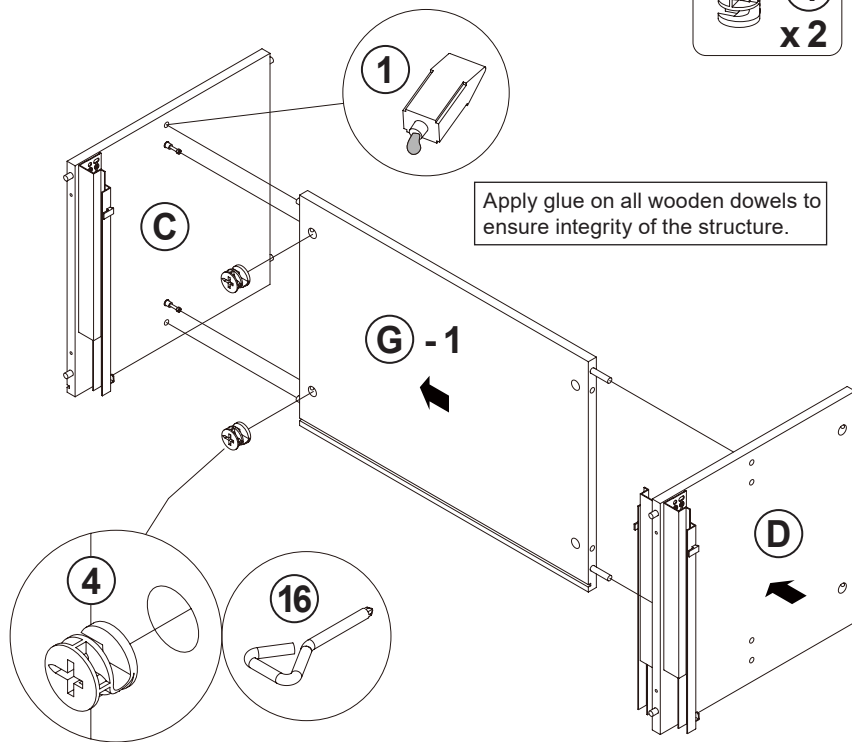
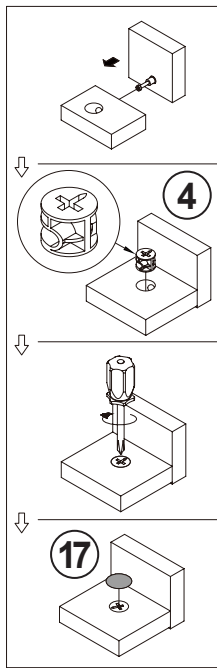

## STEP 7

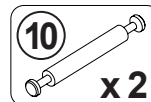
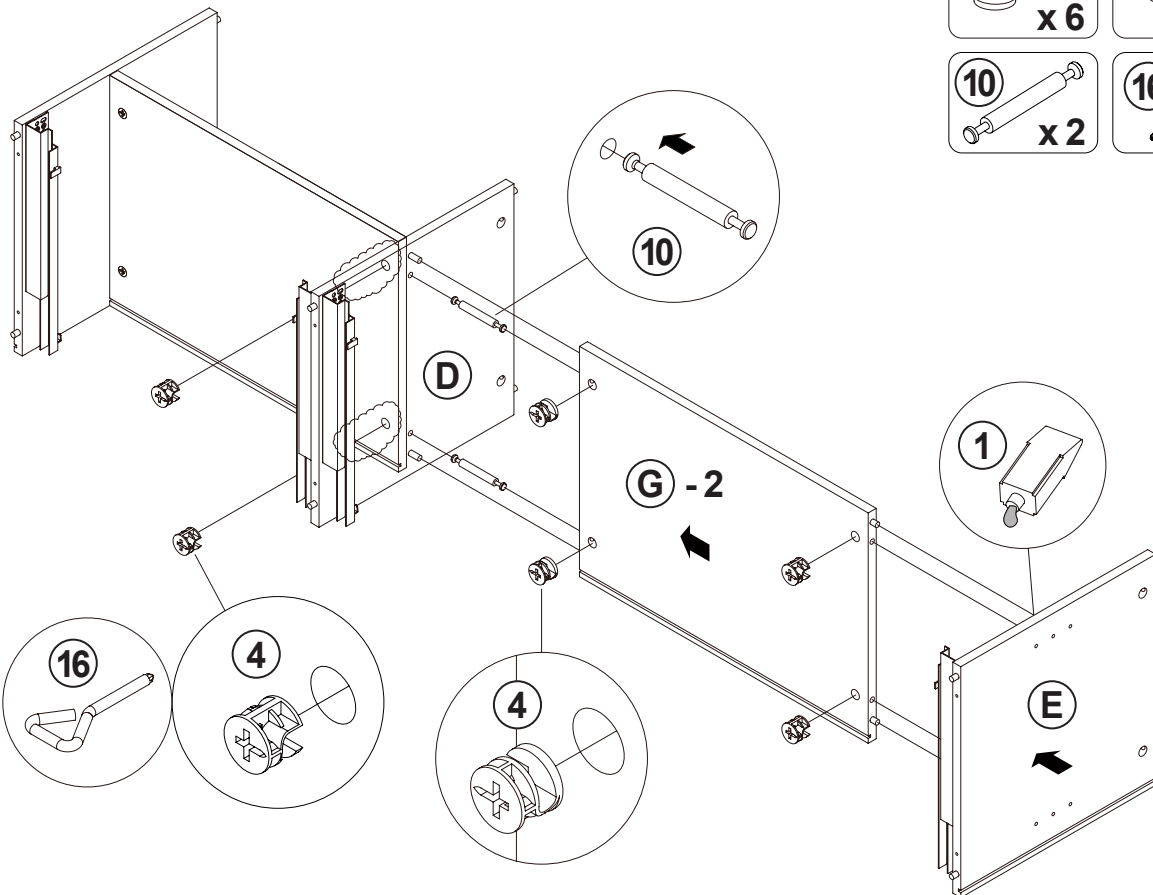

## STEP 8

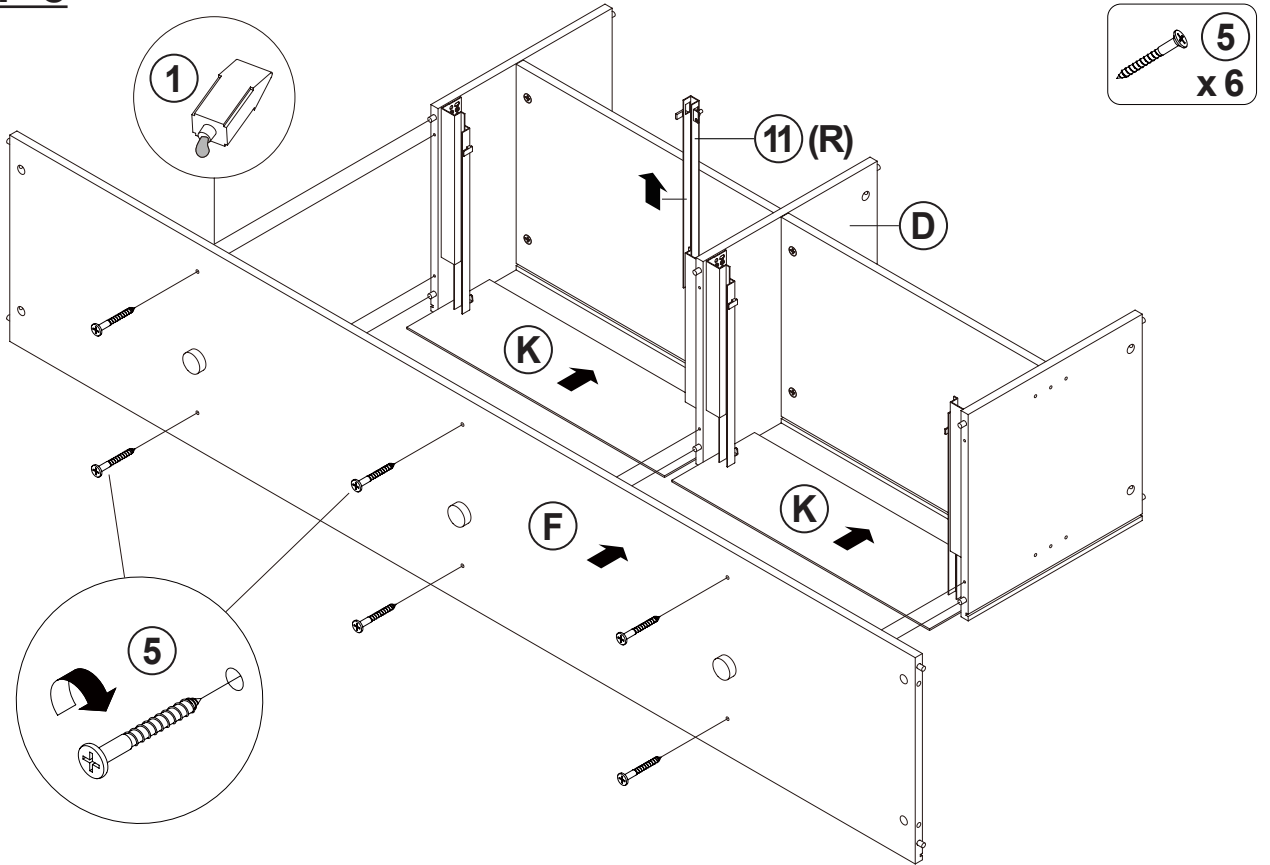

## STEP 9

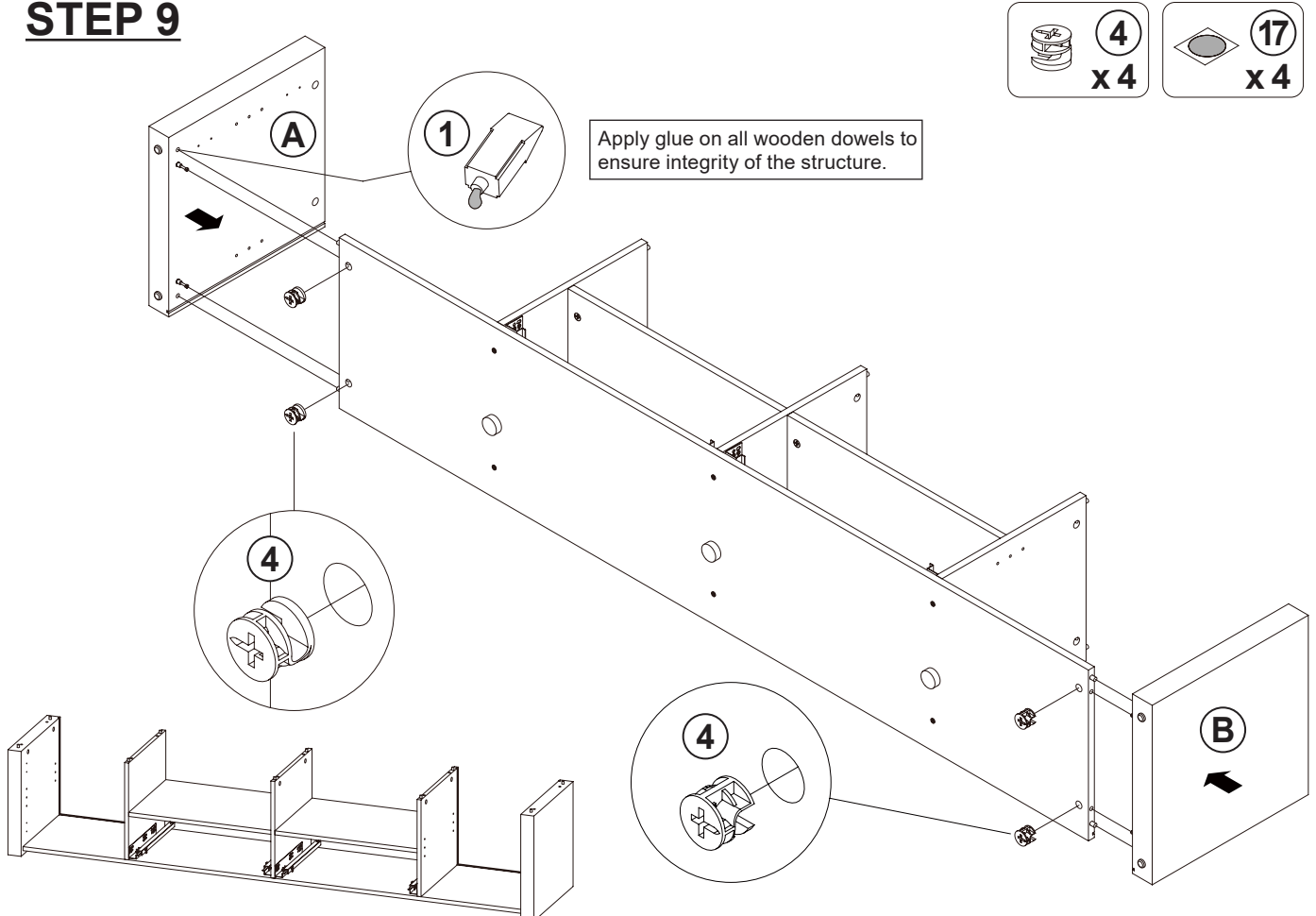

## STEP 10

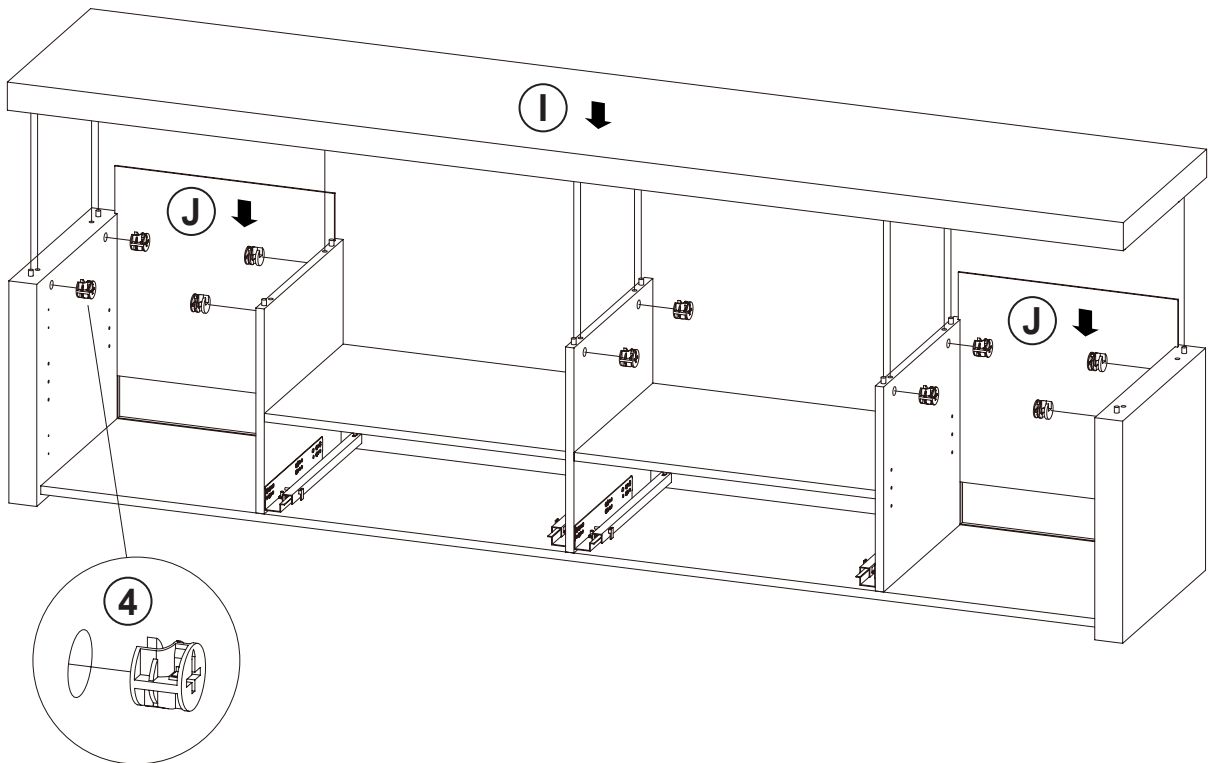
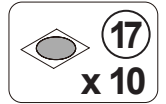
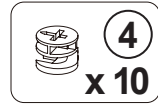

## STEP 11

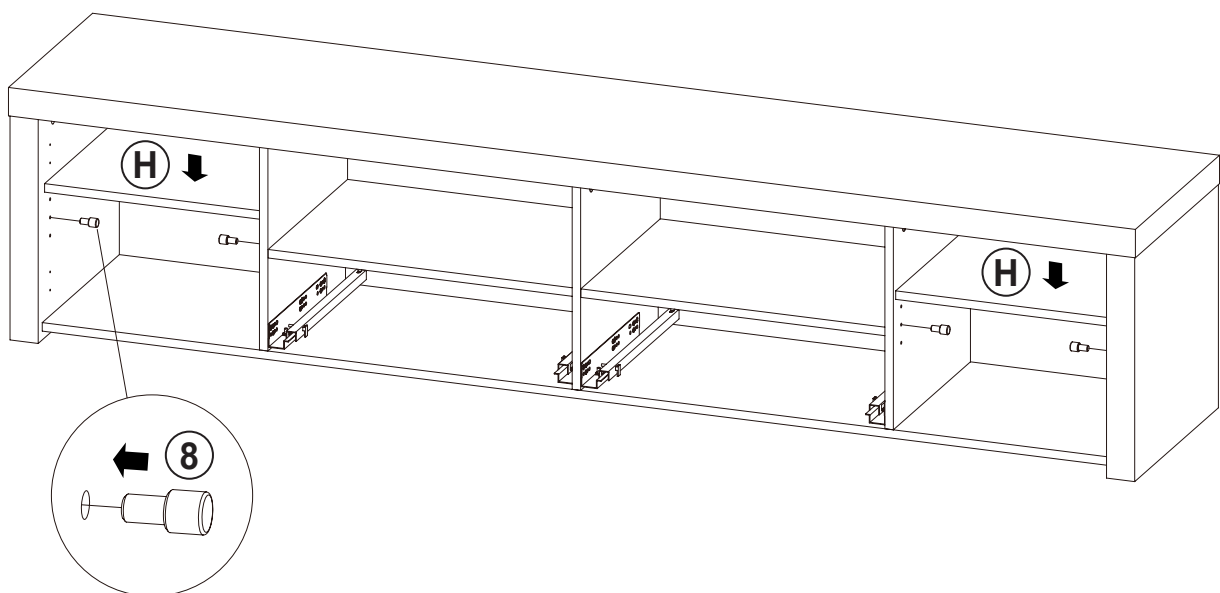
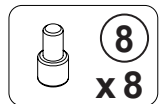

## STEP 12

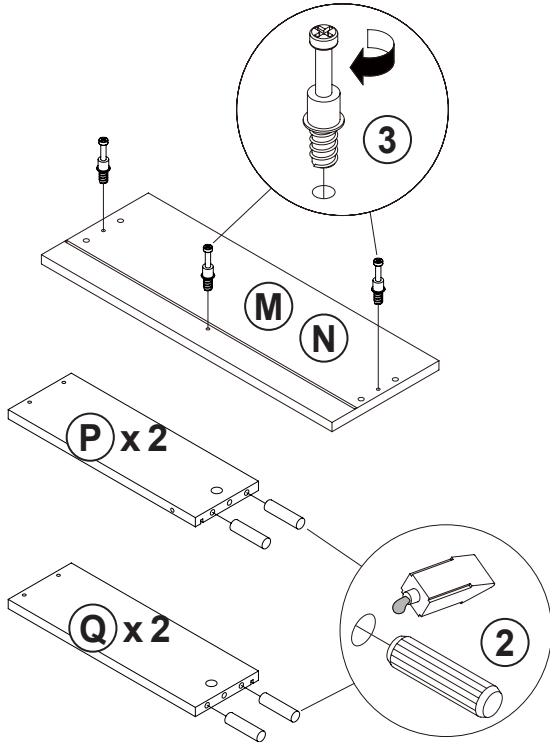
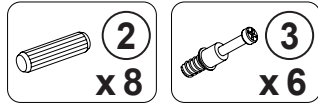

## STEP 13

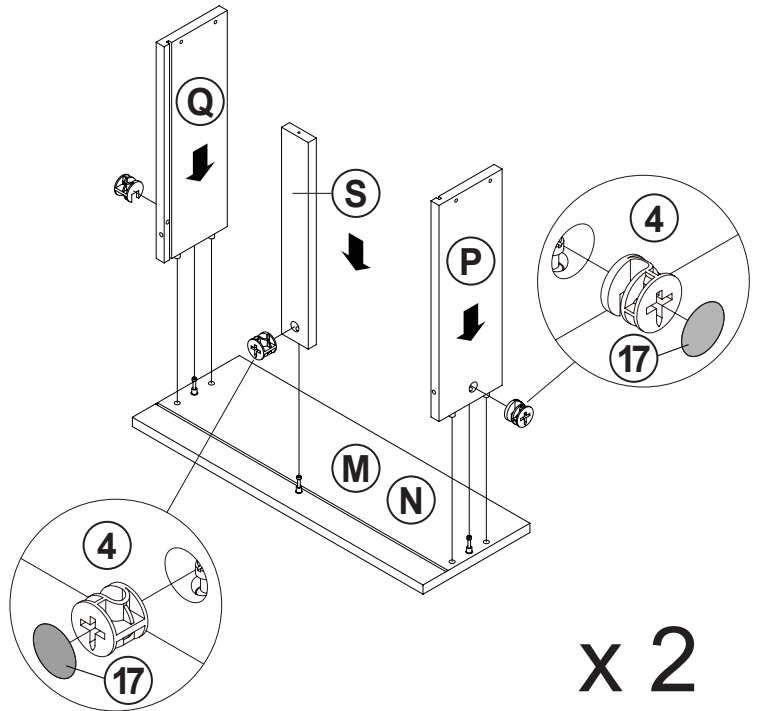
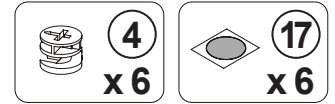

## STEP 14

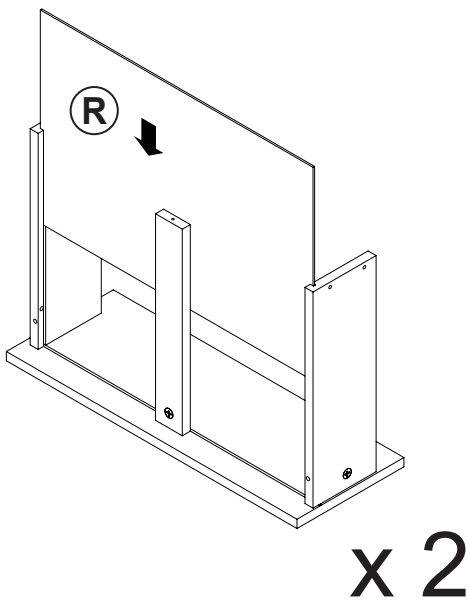

## STEP 15

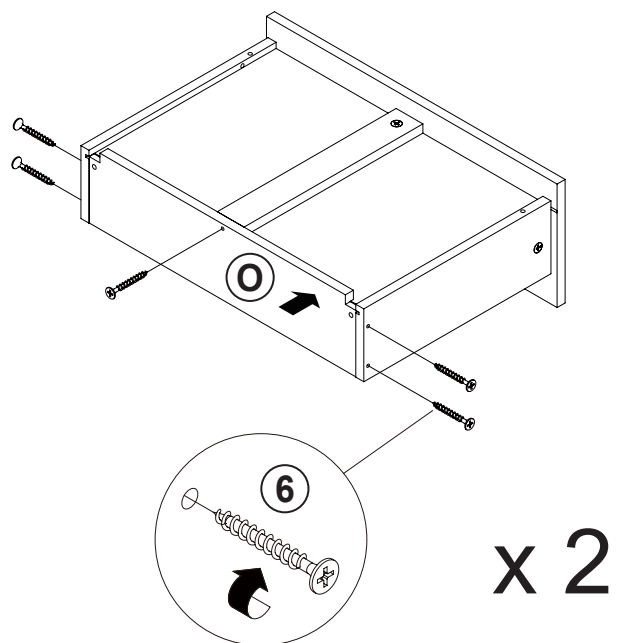
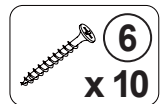

## STEP 16

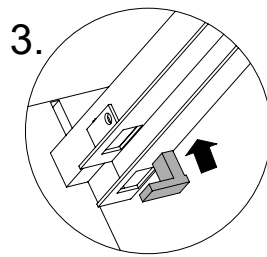
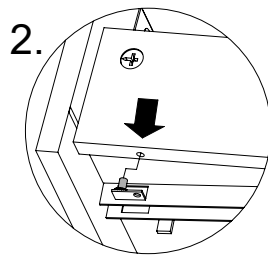
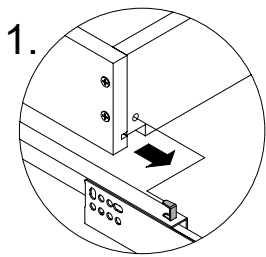
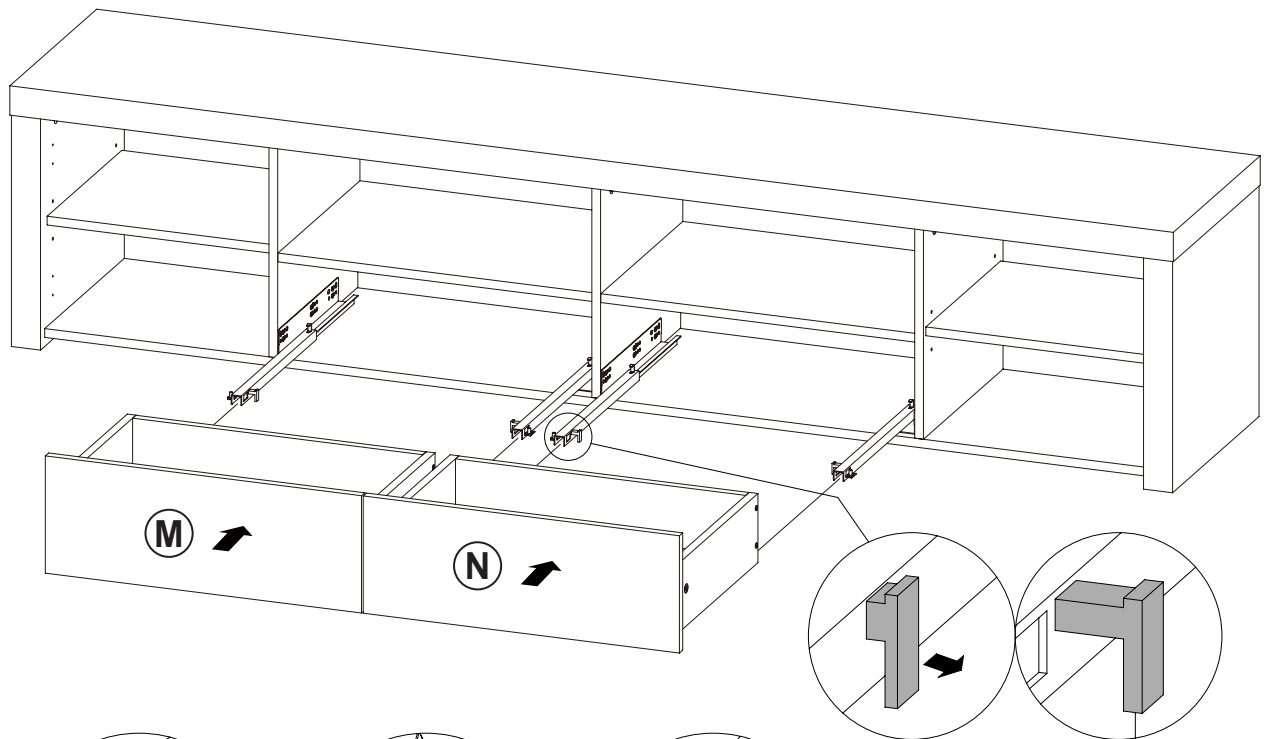

## STEP 17

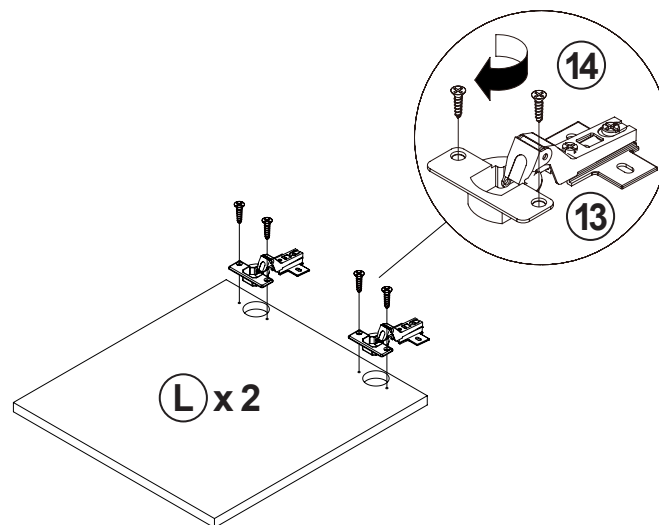

# STEP 18

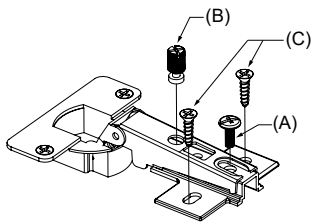
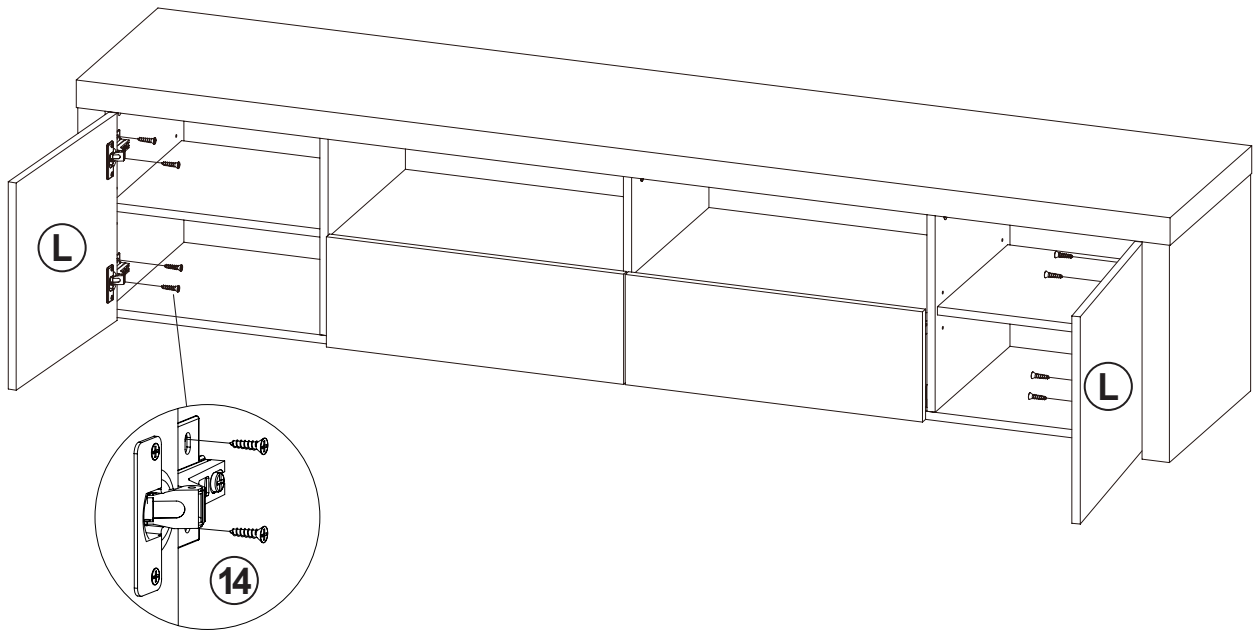
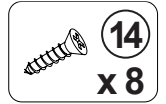

HORIZONTAL BY  
SCREW A ADJUSTMENT

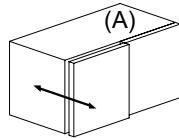

LATERAL BY  
SCREW B ADJUSTMENT

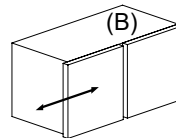

VERTICAL BY  
SCREW C ADJUSTMENT

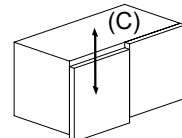

# STEP 19

COMPLETE

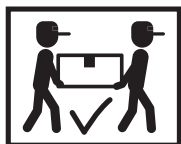
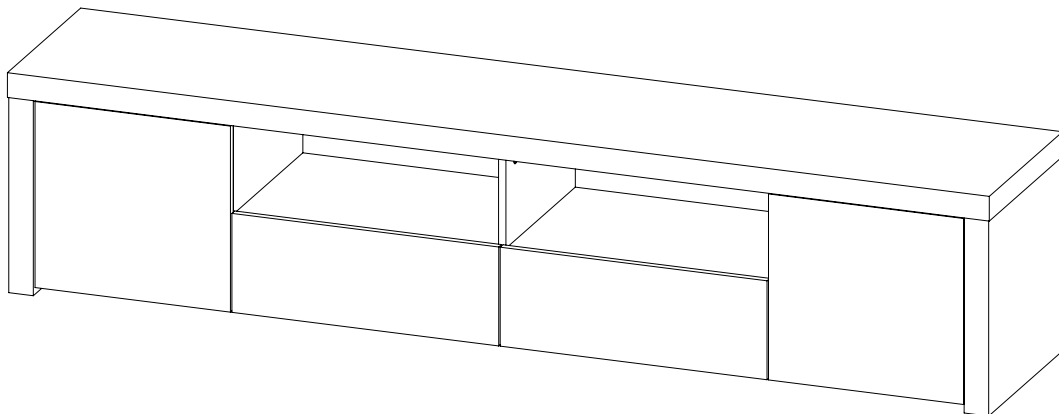

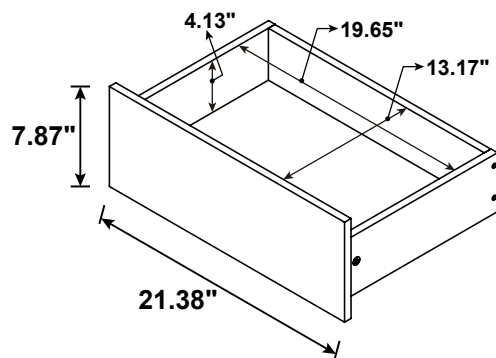
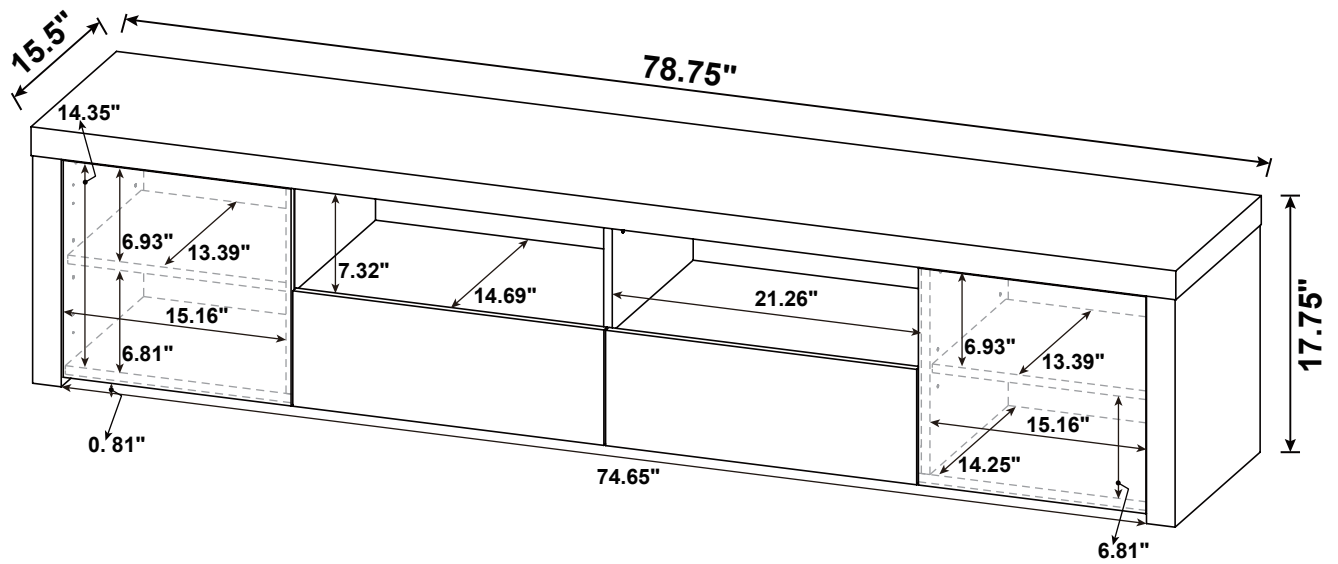

**Note :** Dimension tolerance  $\pm 5\%$