

Wardrobe Installation Manual

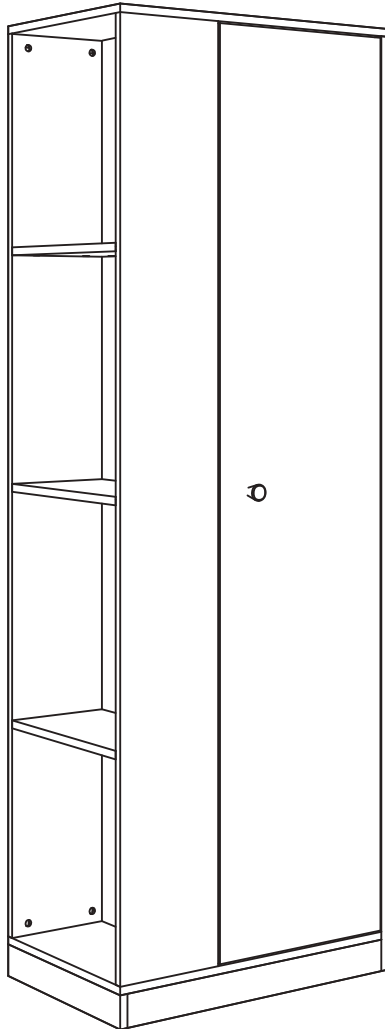

Please read this manual carefully before any operation and keep it properly for future use.

WARNING

Keep all parts out of the children's reach.

NOTE

You need to have a crosshead screwdriver and hammer beforehand.



crosshead screwdriver

Place all the panels on a clean and smooth surface, such as a rug or carpet, to prevent them from being scratched.

Make sure that all parts in your product package, including panels and accessories, match up with those listed in the Panels & Accessories list. Don't tighten screws or bolts until all the pieces are fitted.

It is recommended to have 2 persons to complete the assembly.

Furniture Assembly Manual

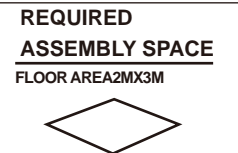
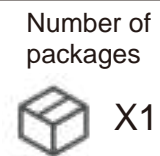
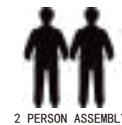

Maintenance skills

1. Use a clean and soft cloth to remove dust regularly; do not use solvents;
2. If you are in a humid environment for a long time, you must ventilate and exhaust moisture to avoid the furniture from being immersed in water;
3. Keep away from high temperature sources such as stoves, radiators, etc. to prevent the furniture from deforming.





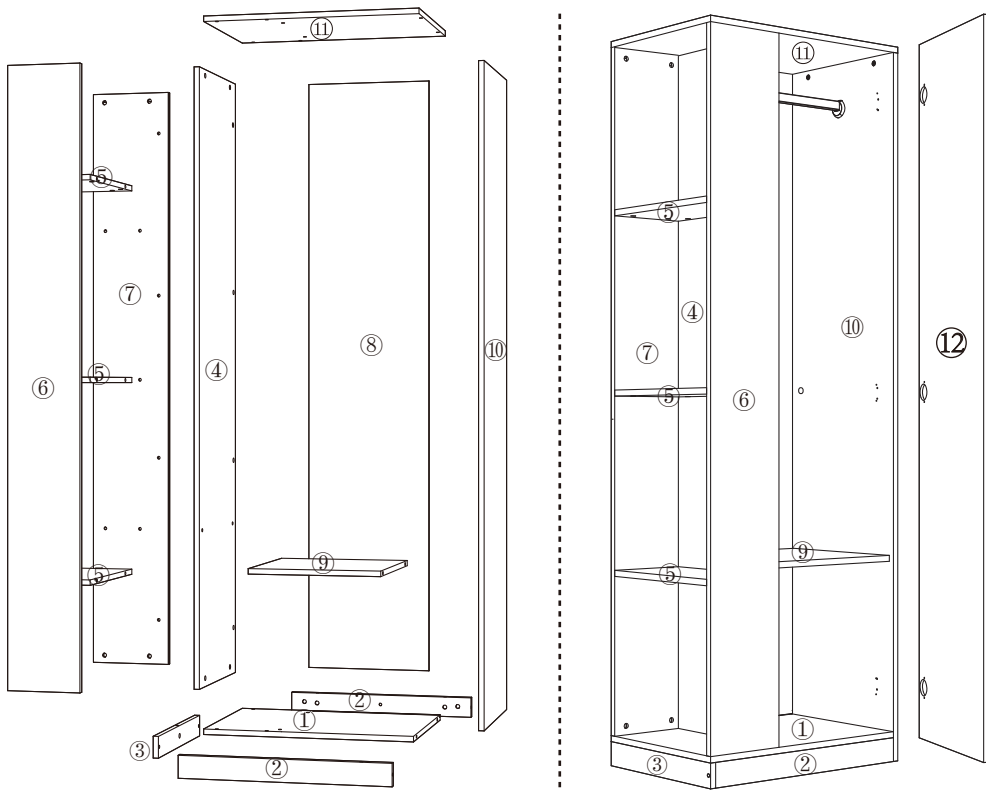

Panel& PanelNumber

Please place the panel on the carpet to prevent scratching







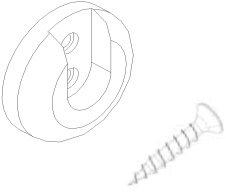
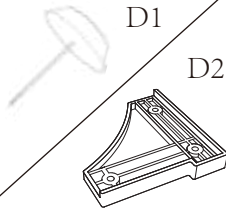
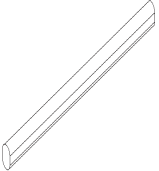

Accessories List

Installation Guide

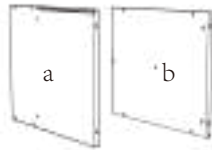
NO.	Reference image	QTY	NO.	Reference image	QTY
(A)		*52	(E)		*4
(B)		*52	(F)		*3
(C)		*28	(G)		*1
(D)		D1*6 D2*4	(H)		G1*2 G2*4

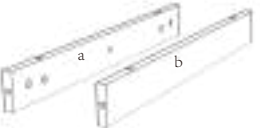
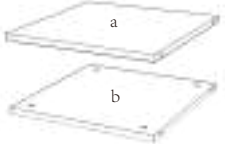
Parts List

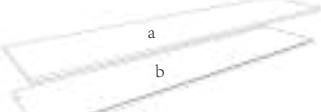
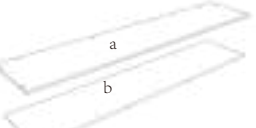
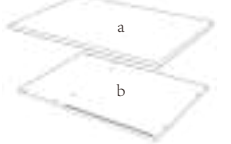
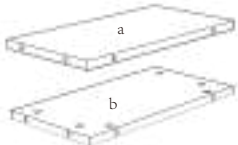
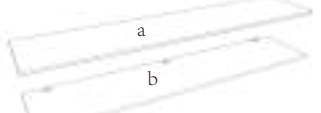
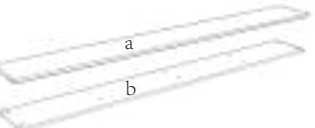
Installation Guide

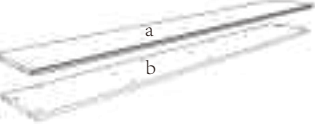
NO.	Reference image	QTY	NO.	Reference image	QTY
①		*1	⑧		*1
②		*2	⑨		*1
③		*1	⑩		*1
④		*1	⑪		*1
⑤		*3	⑫		*1
⑥		*1	⑬		*1
⑦		*1			

Installation of Cams and Pins

Screw the pin into the hole. To set the cams correctly, ensure that the arrow on the cam is opening to the hole of the pin it is locking. Lock the cam by turning the cam head with a screwdriver until it is tightened.

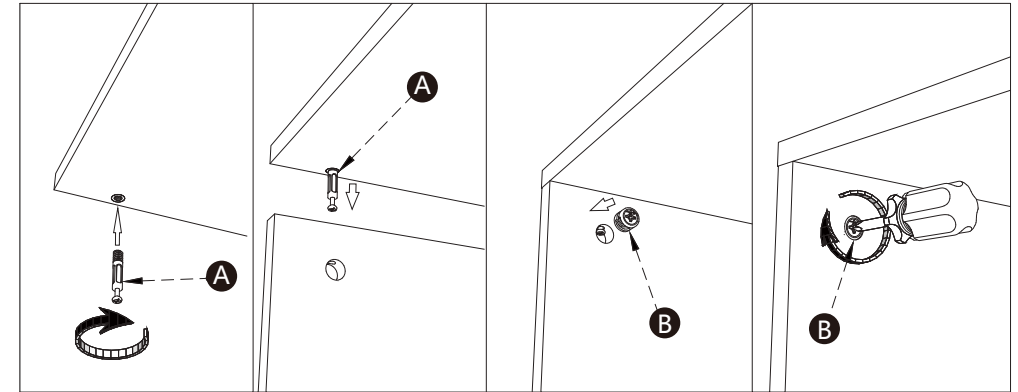

Read each step carefully before starting. It is very important that each step of instruction is performed in the correct order. If these steps are not followed in sequence, assembly difficulties will occur.

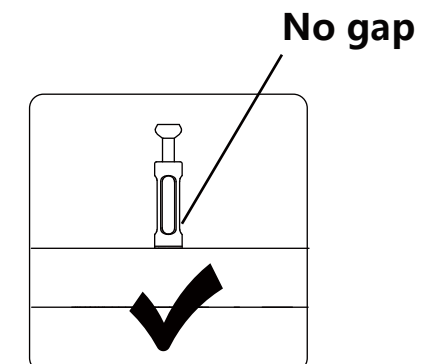
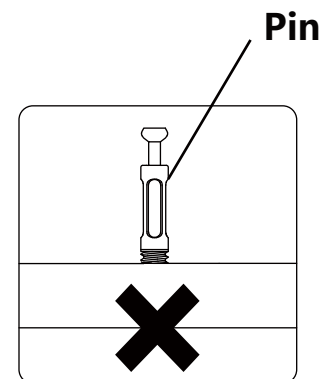

STEP 1

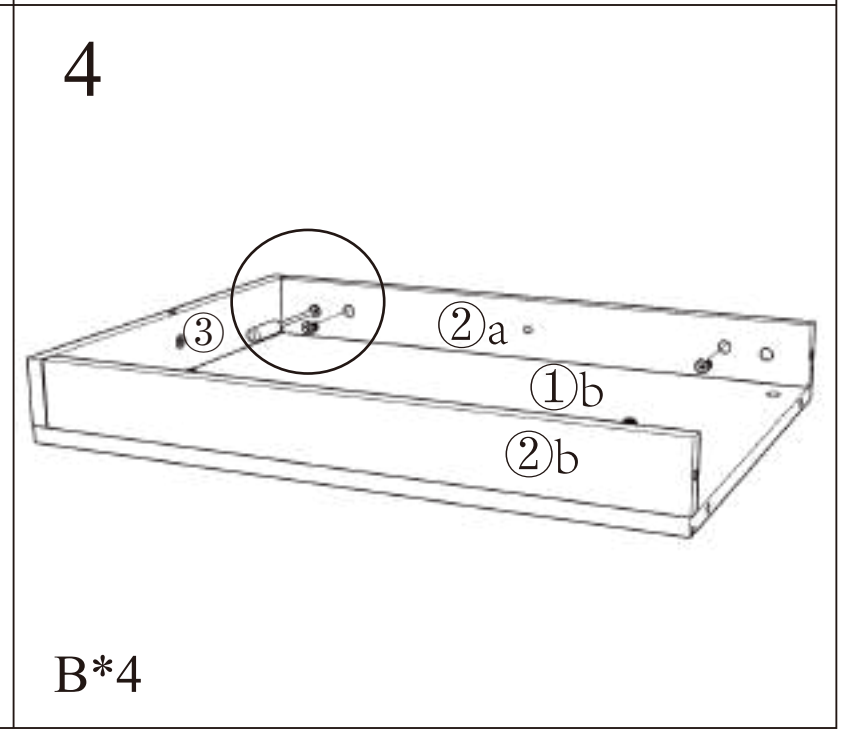
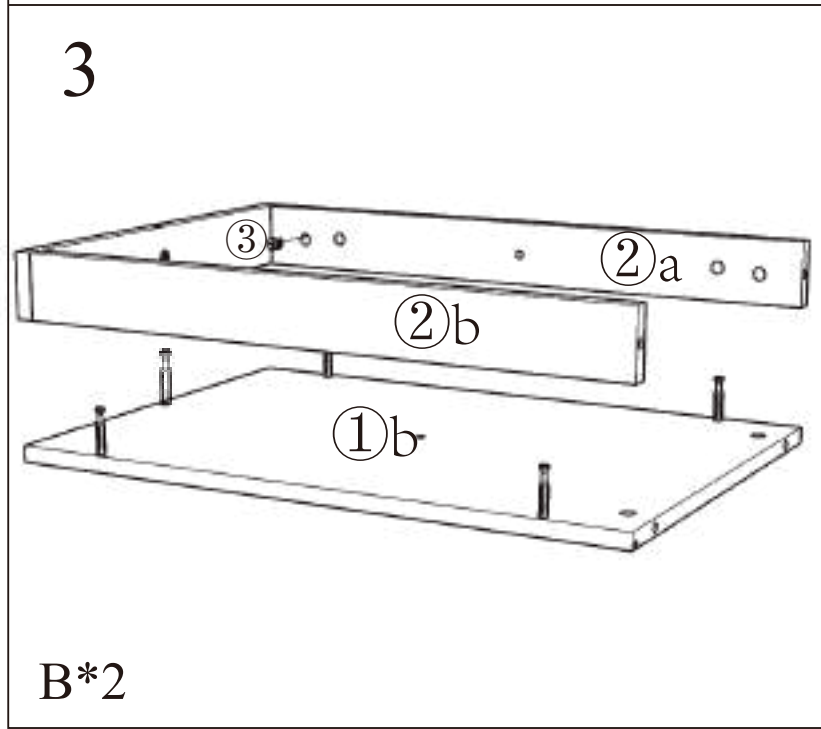
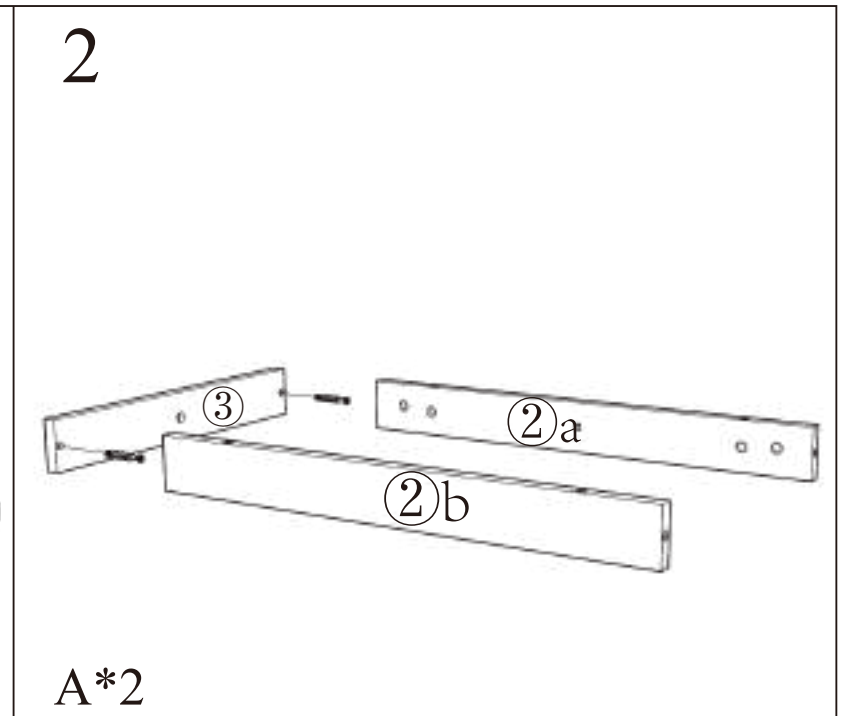
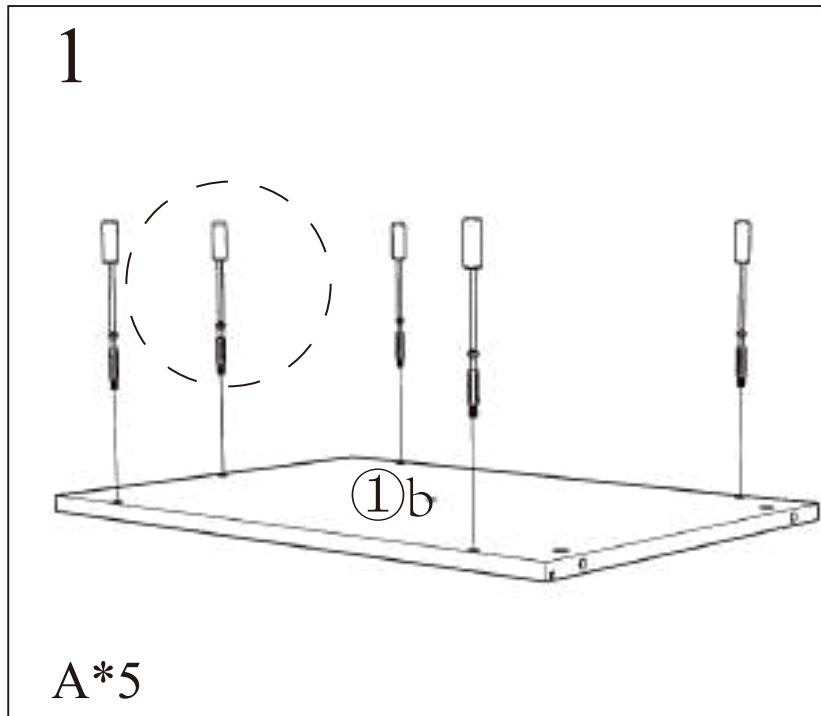
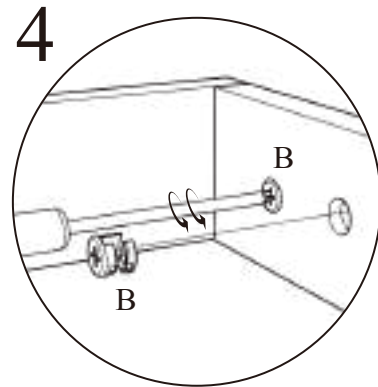
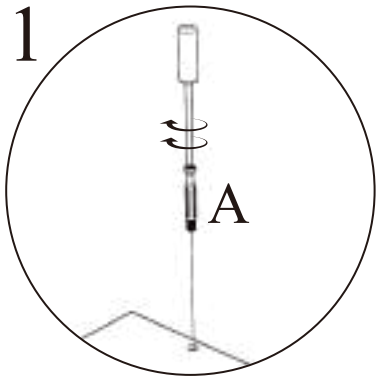

STEP 2

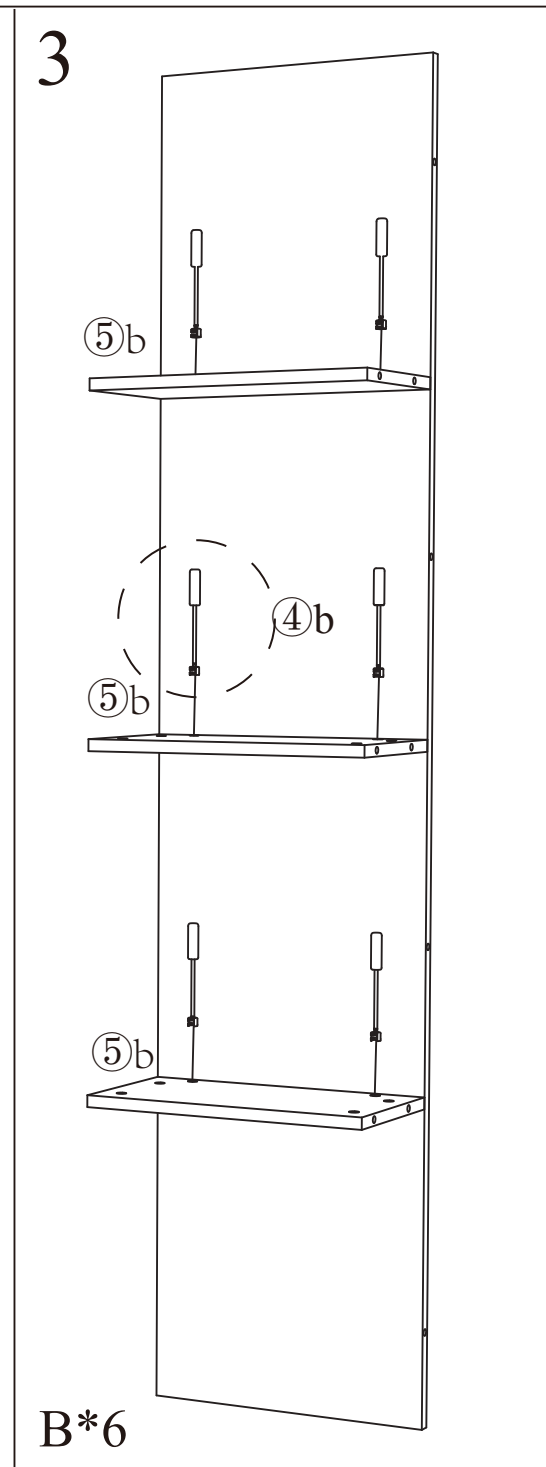
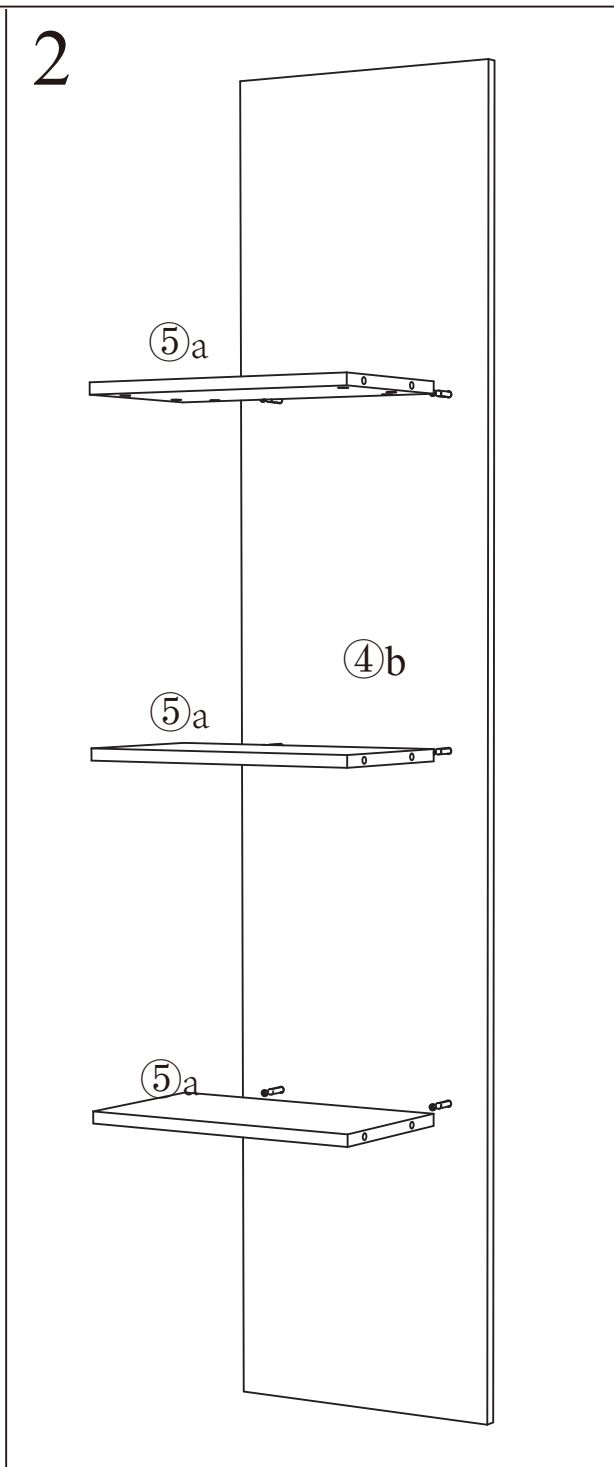
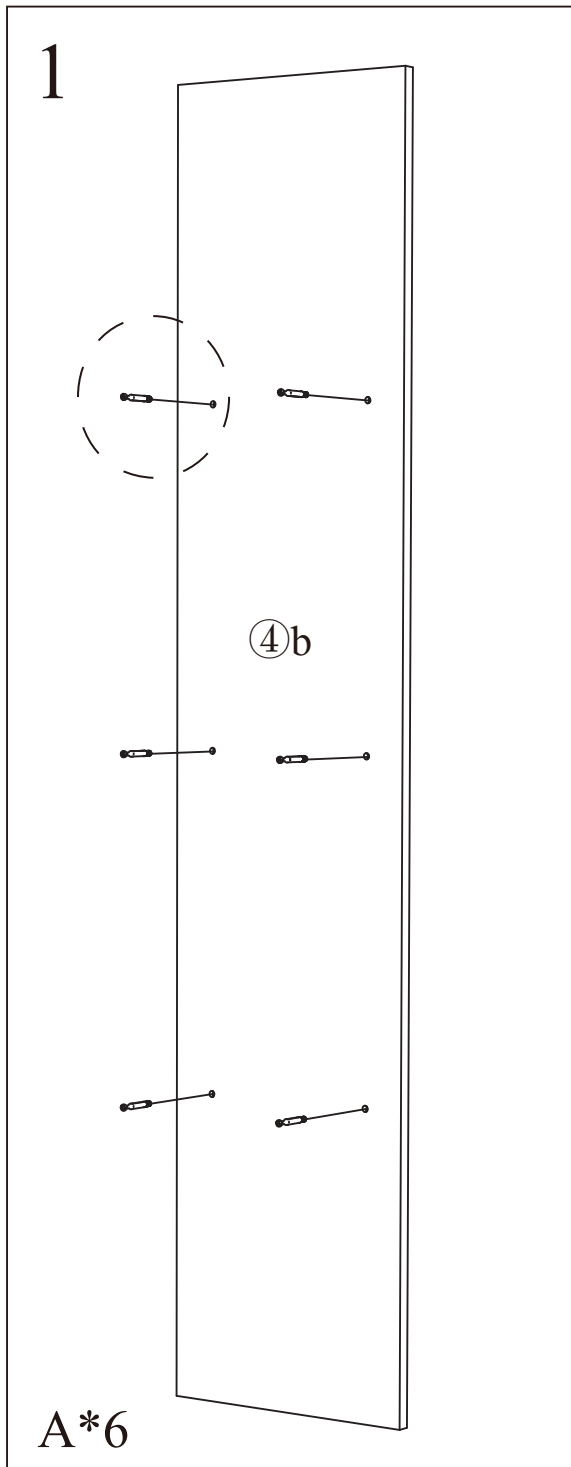
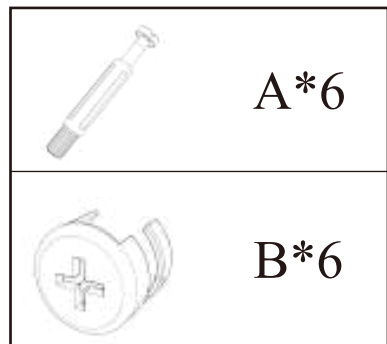
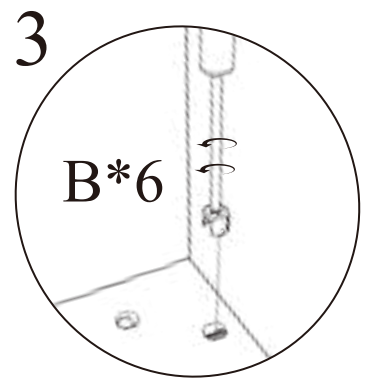
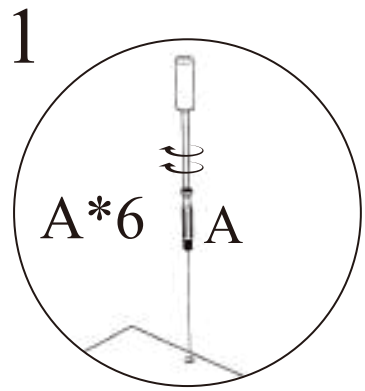

STEP 3

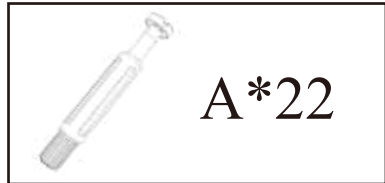
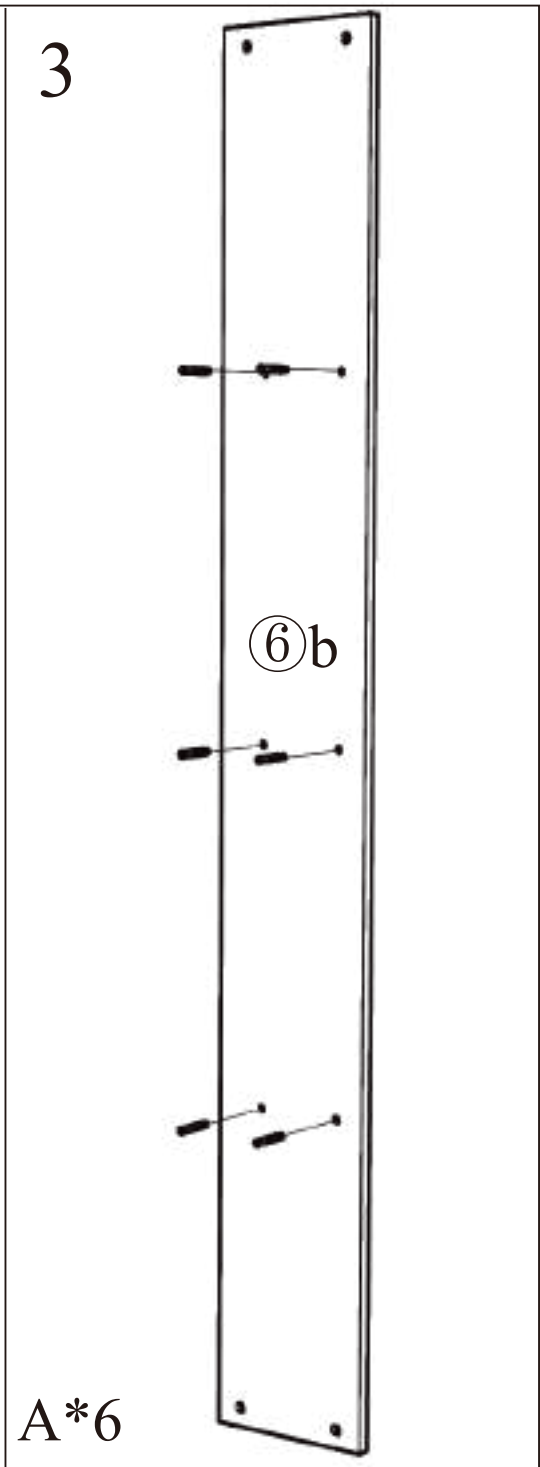
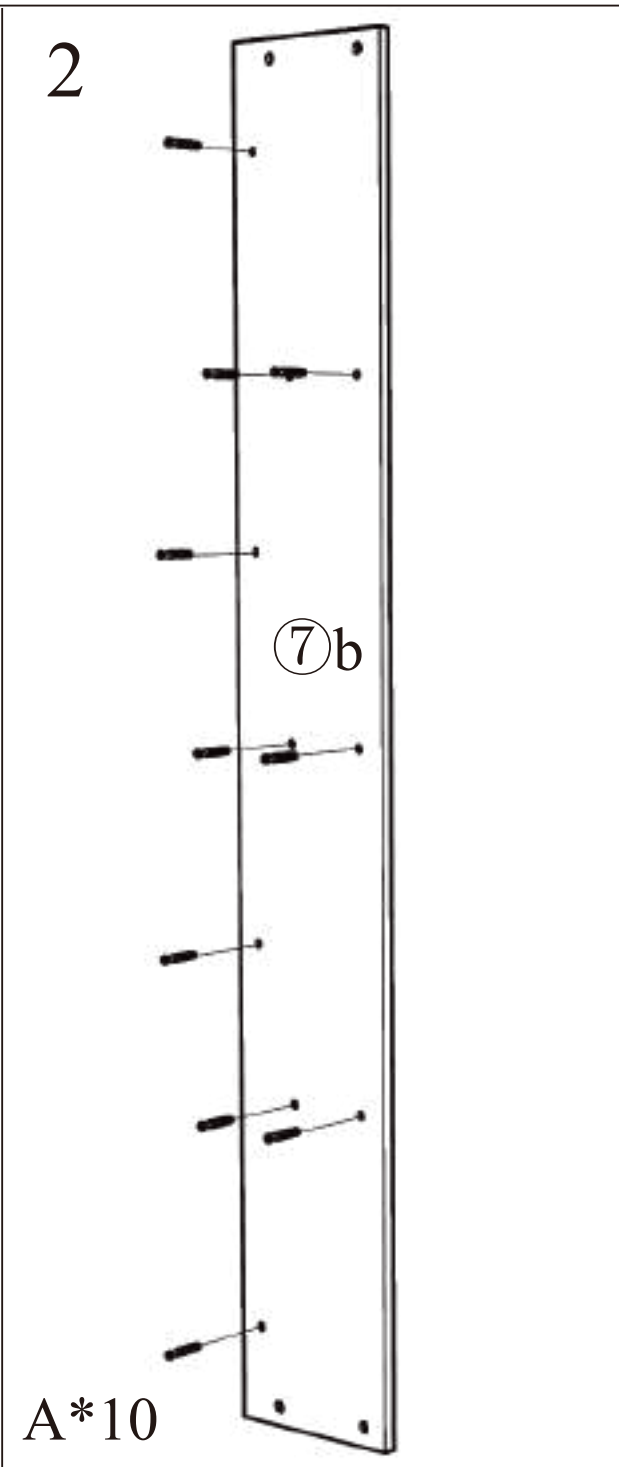
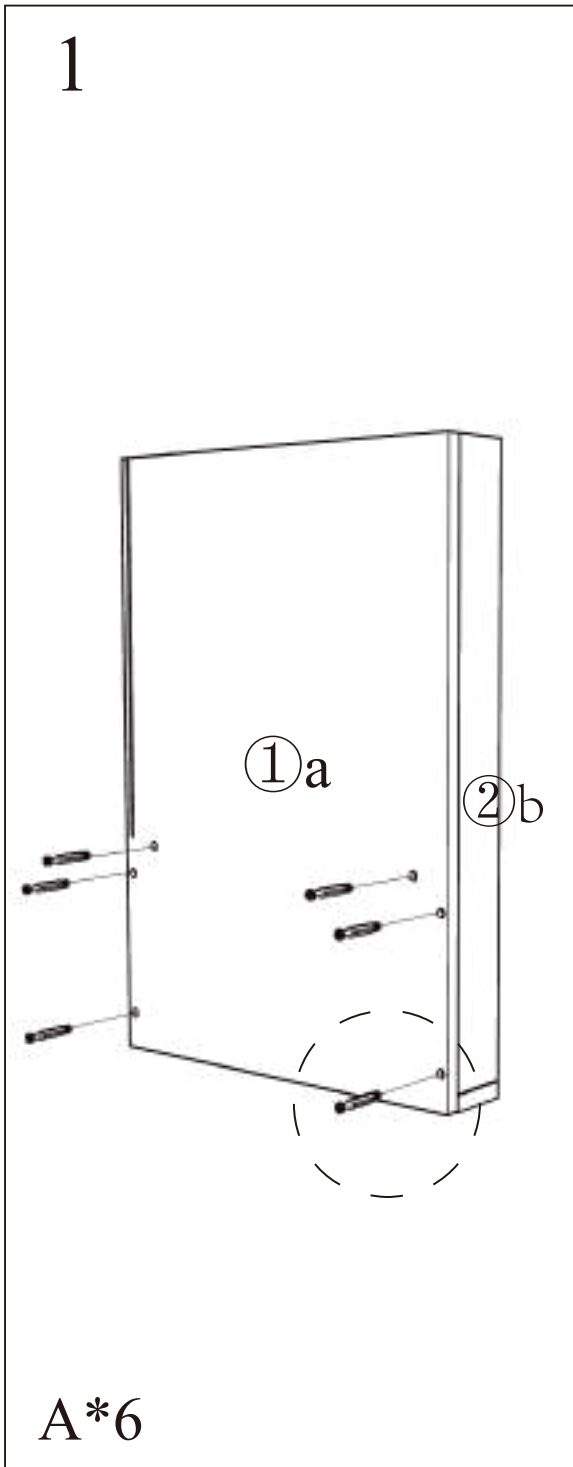
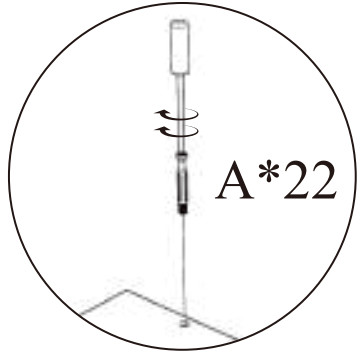

STEP 4

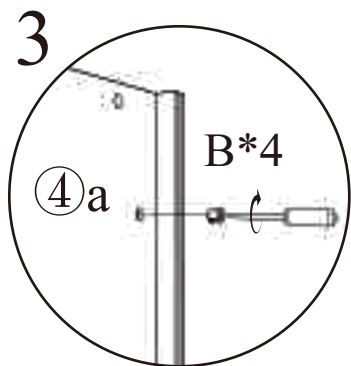
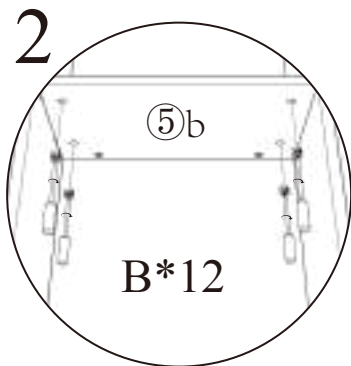
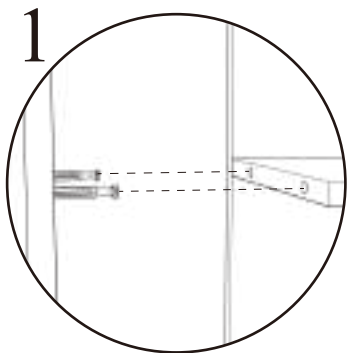

B*16

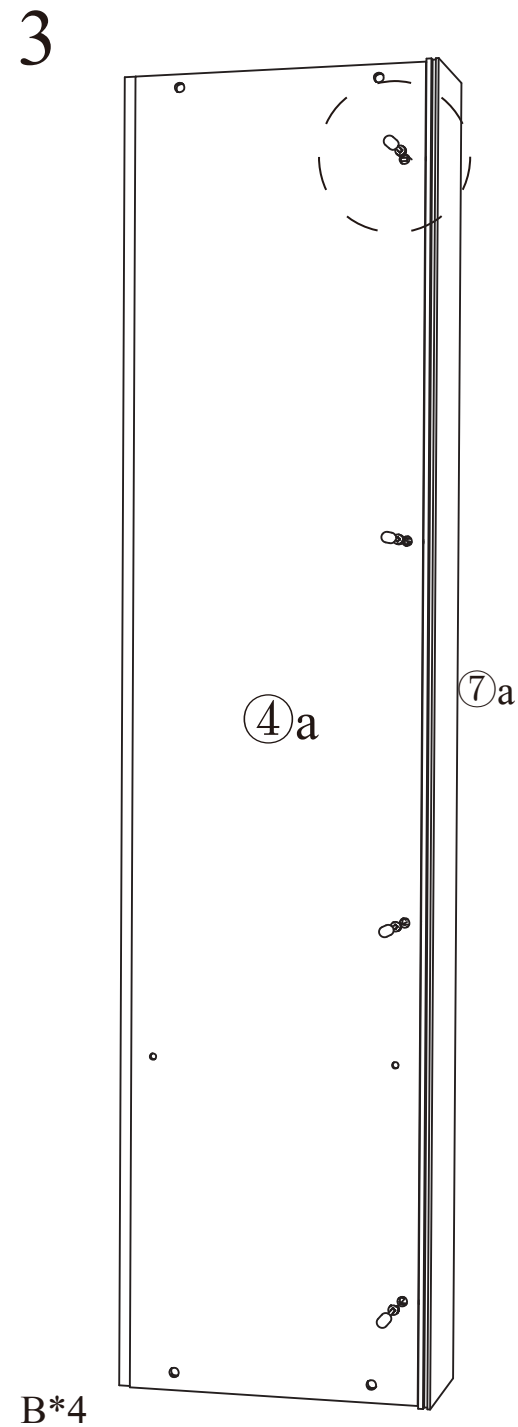
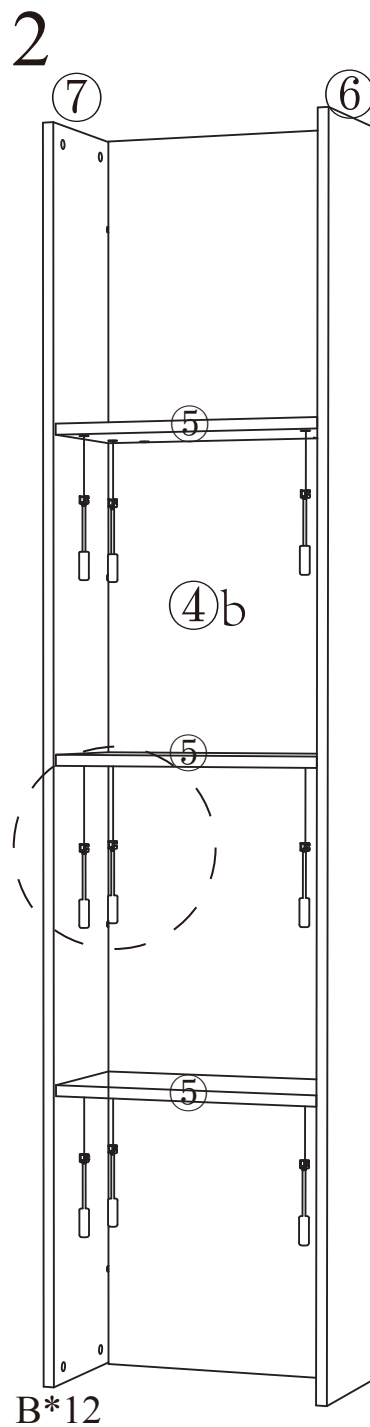
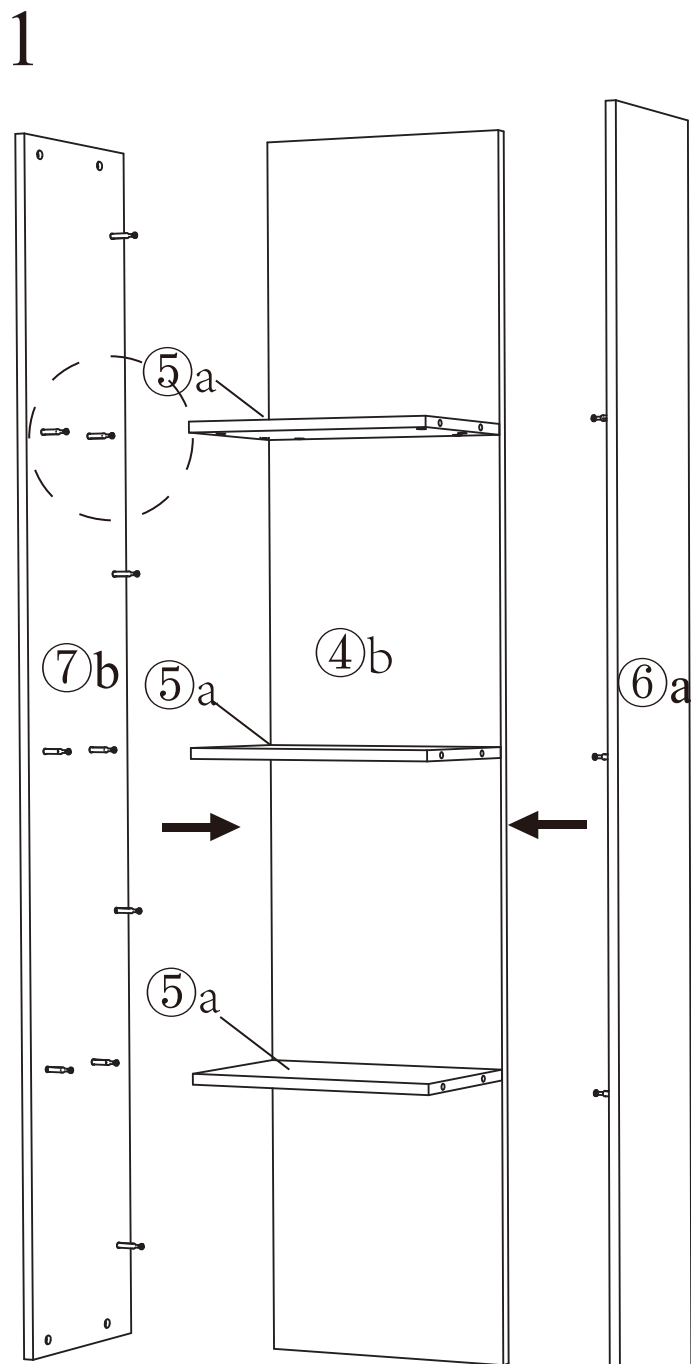

STEP 5

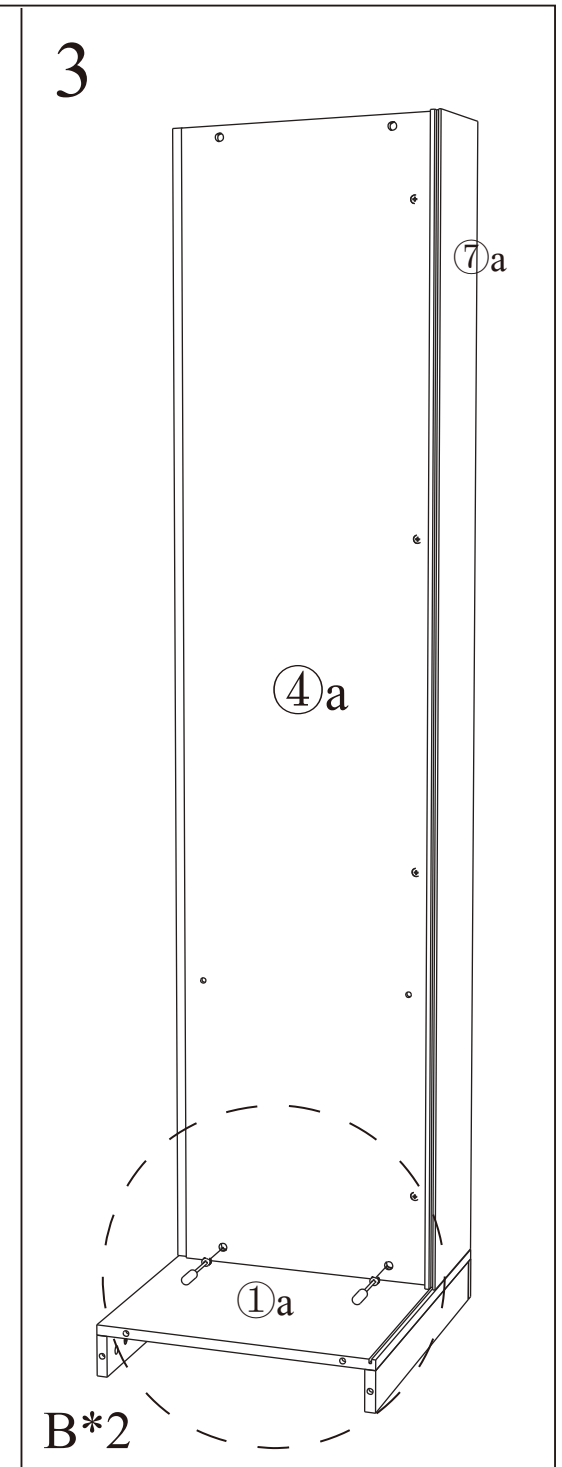
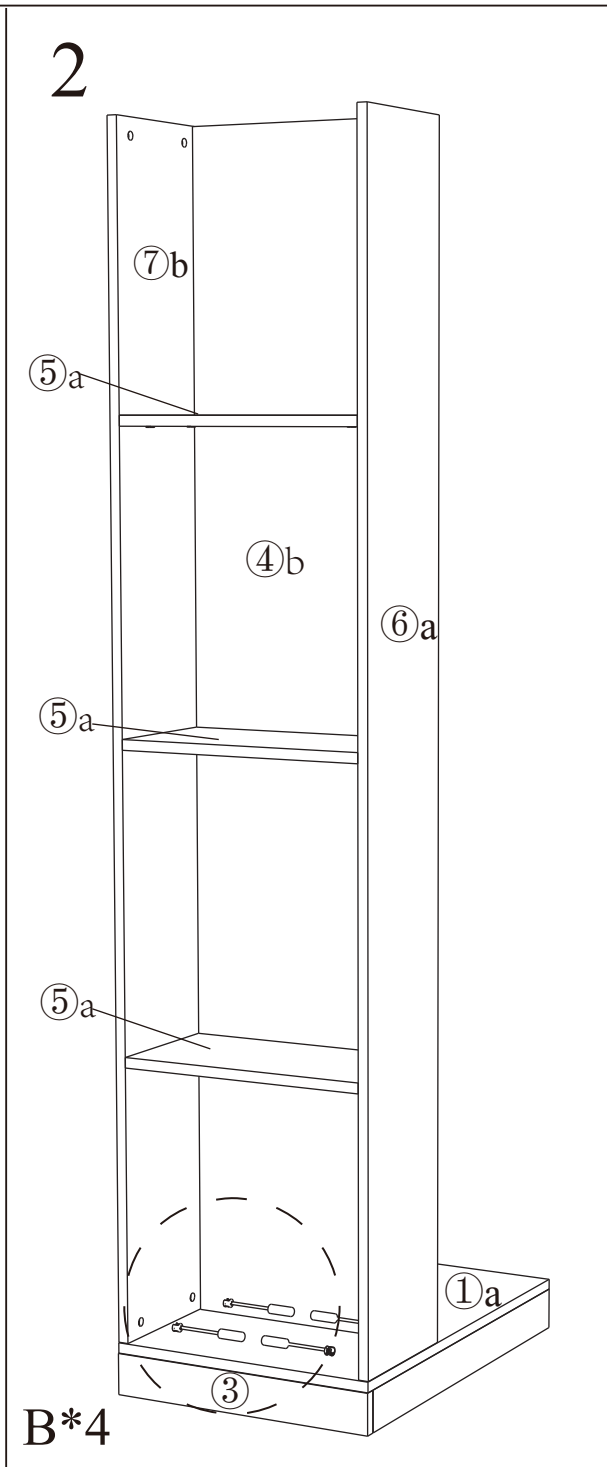
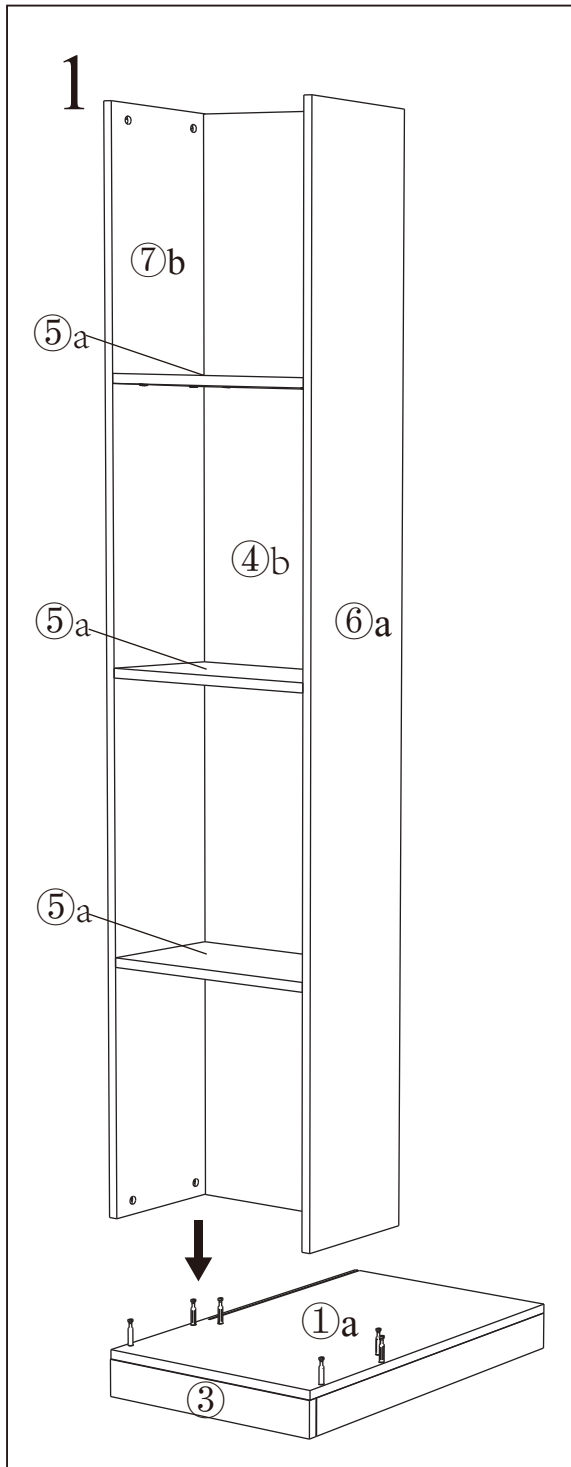
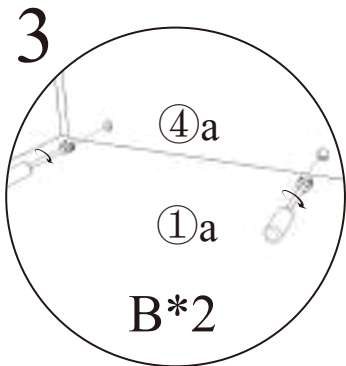
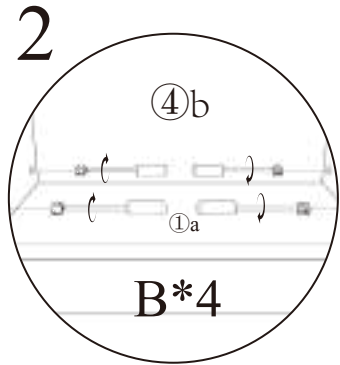

STEP 6

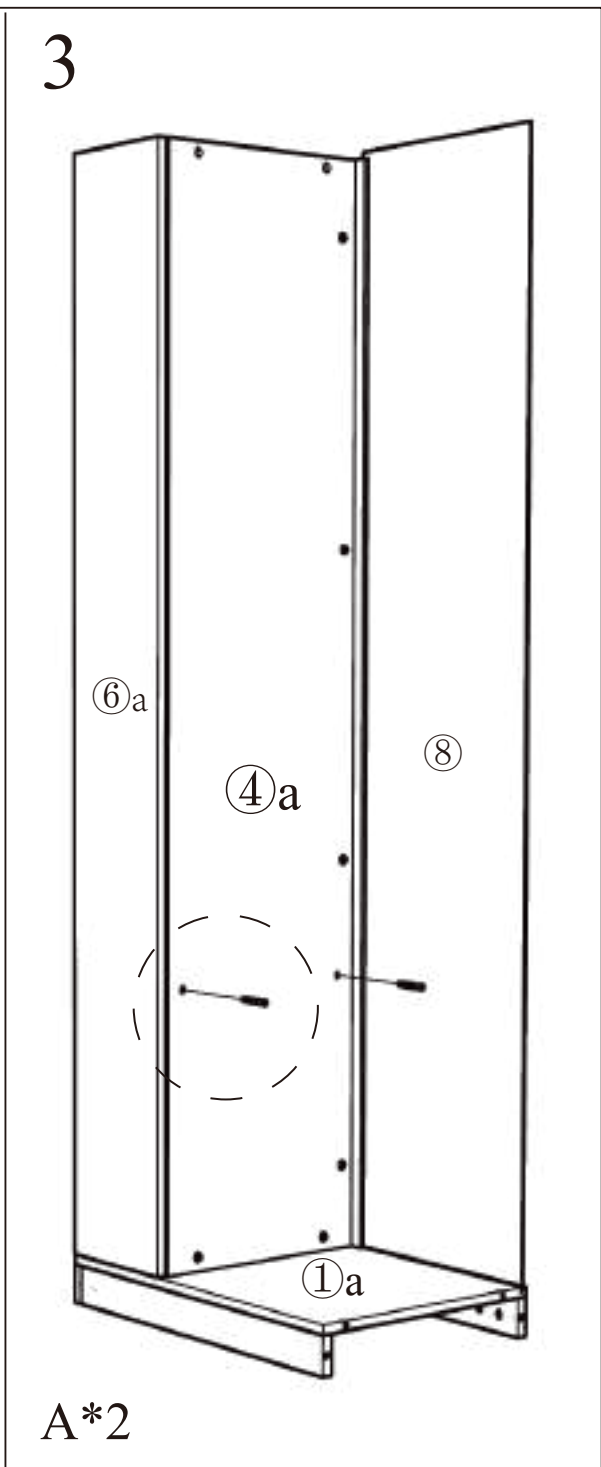
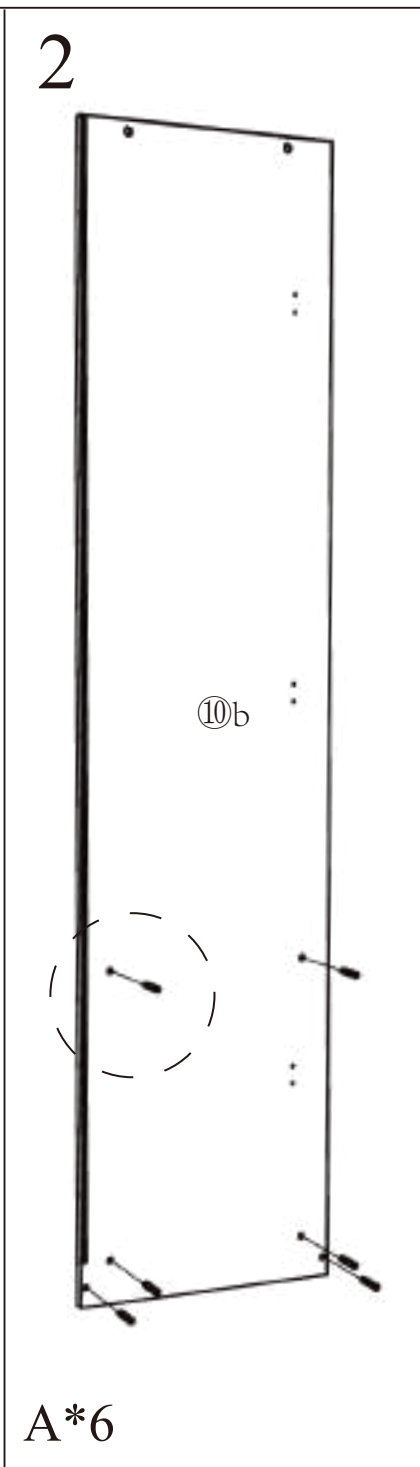
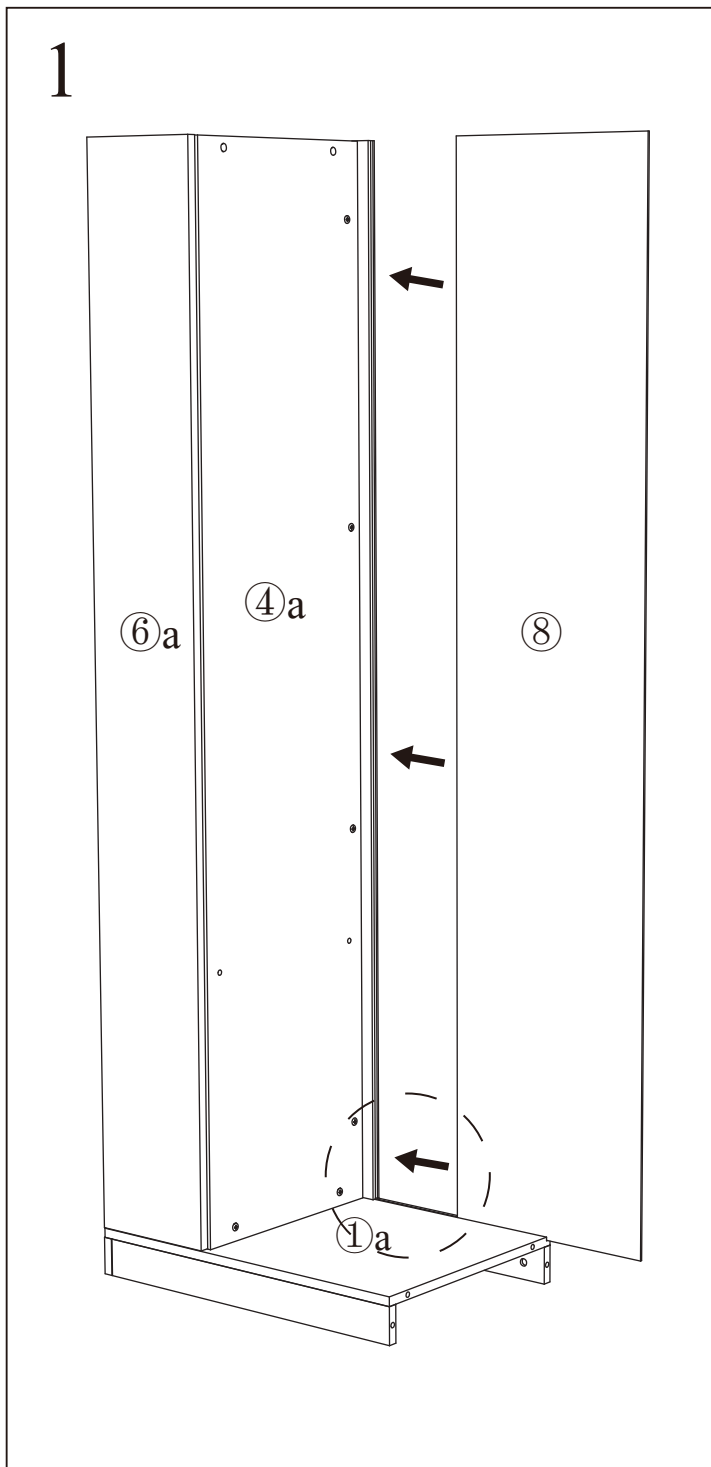
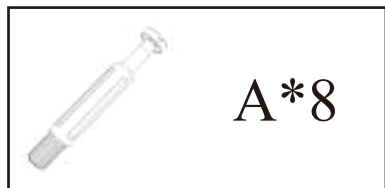
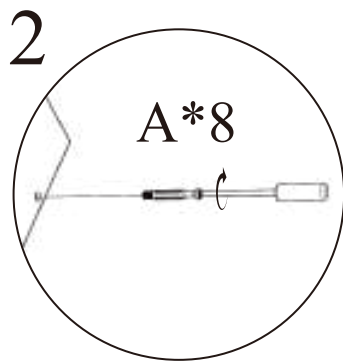
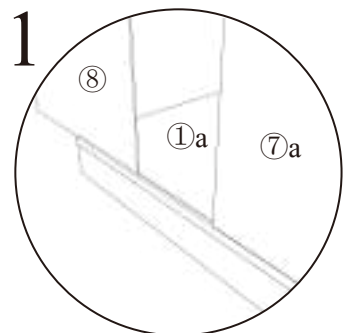
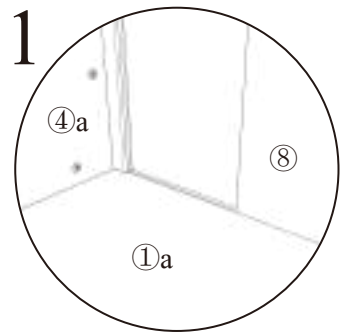

STEP 7

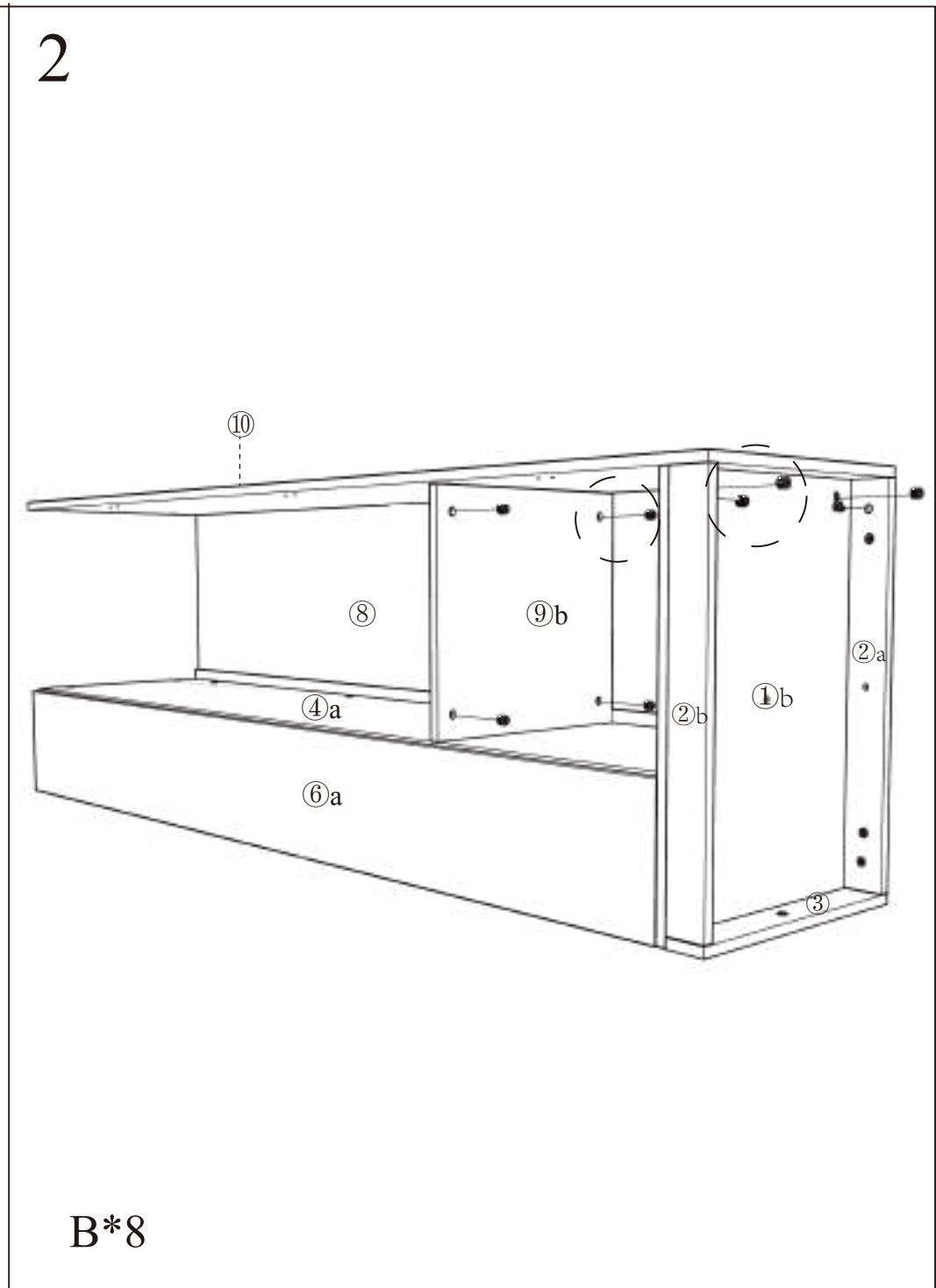
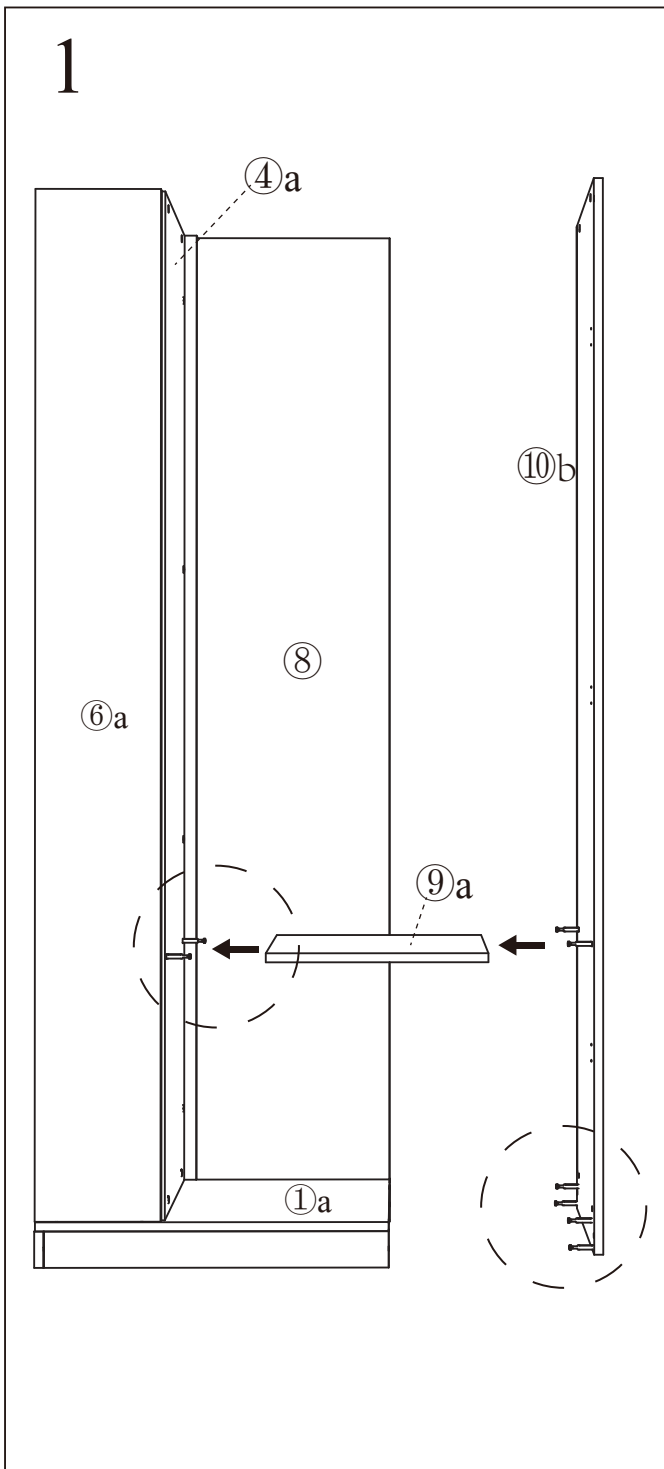
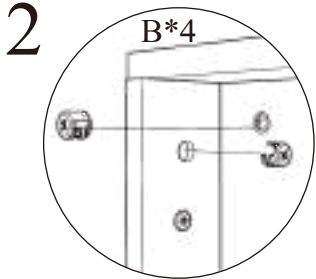
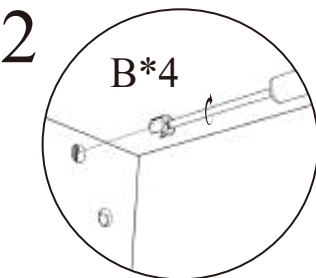
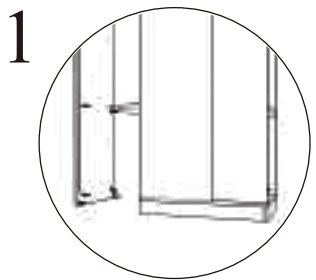
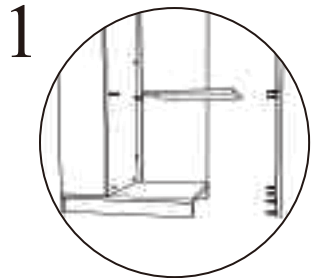

STEP 8

1

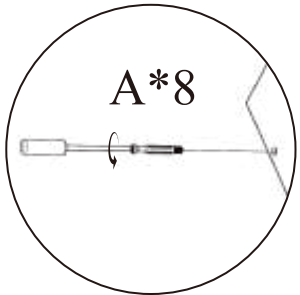

3

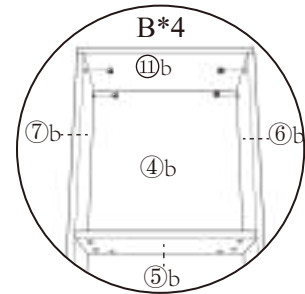

3

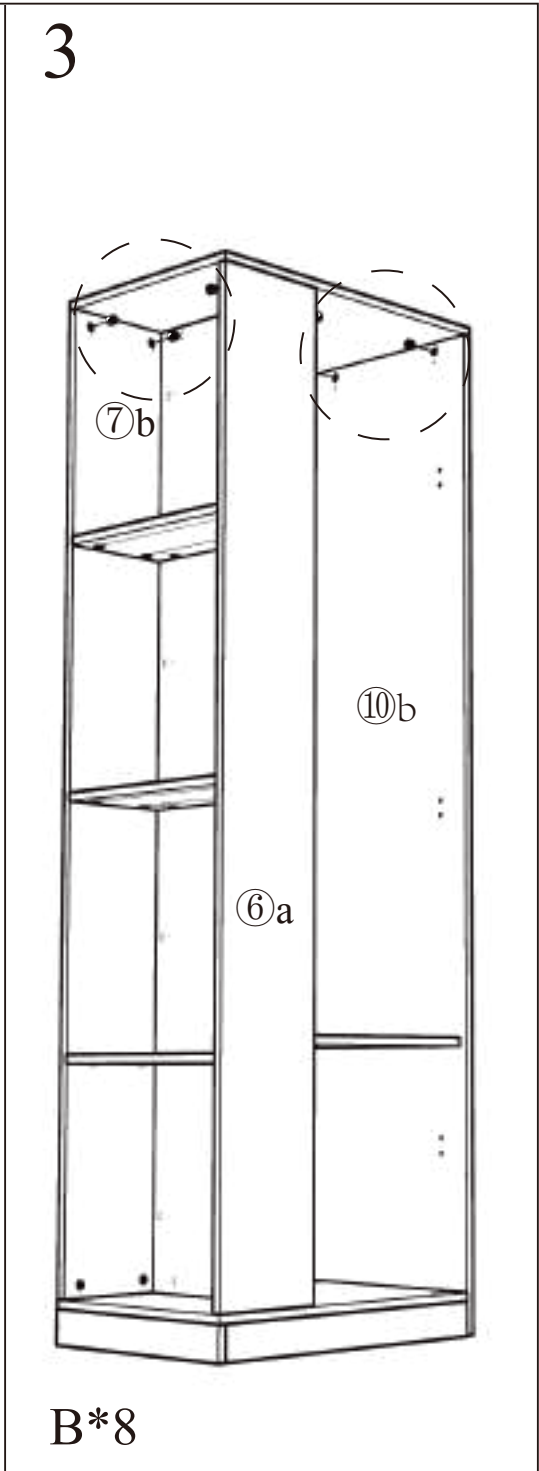
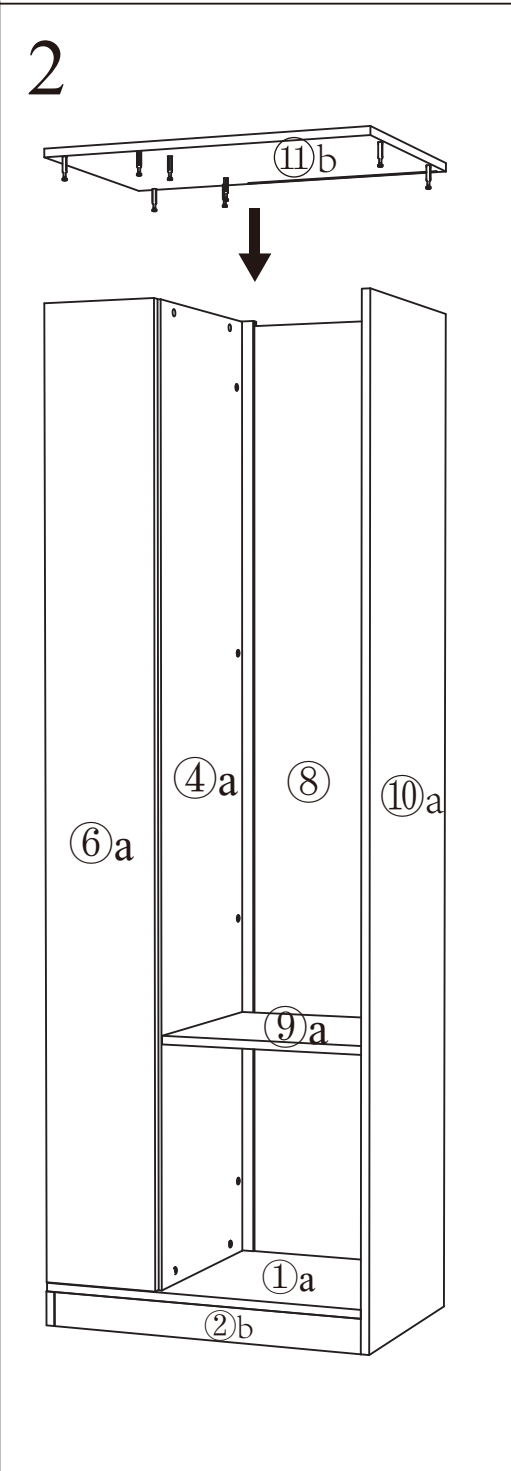
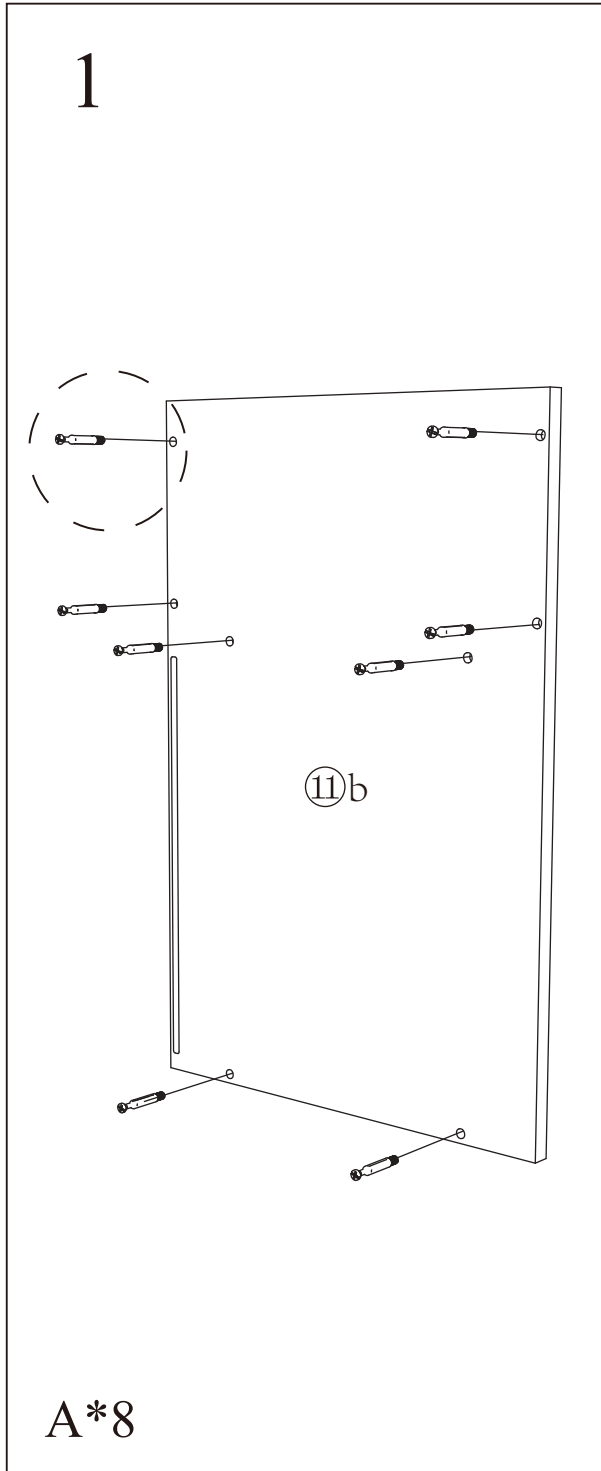
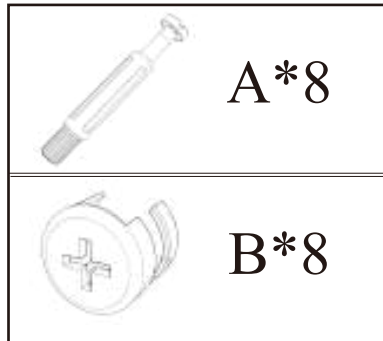
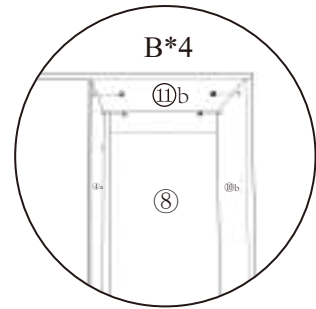

STEP 9

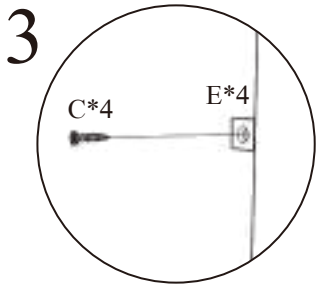
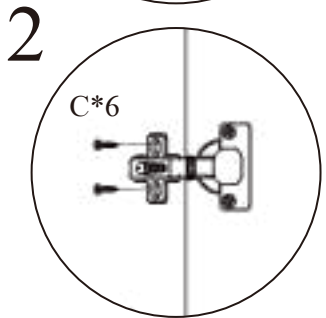
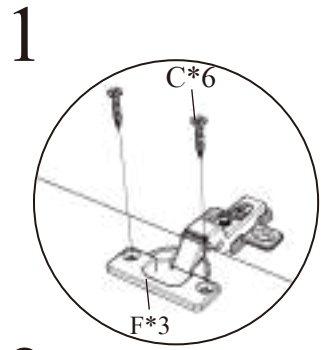



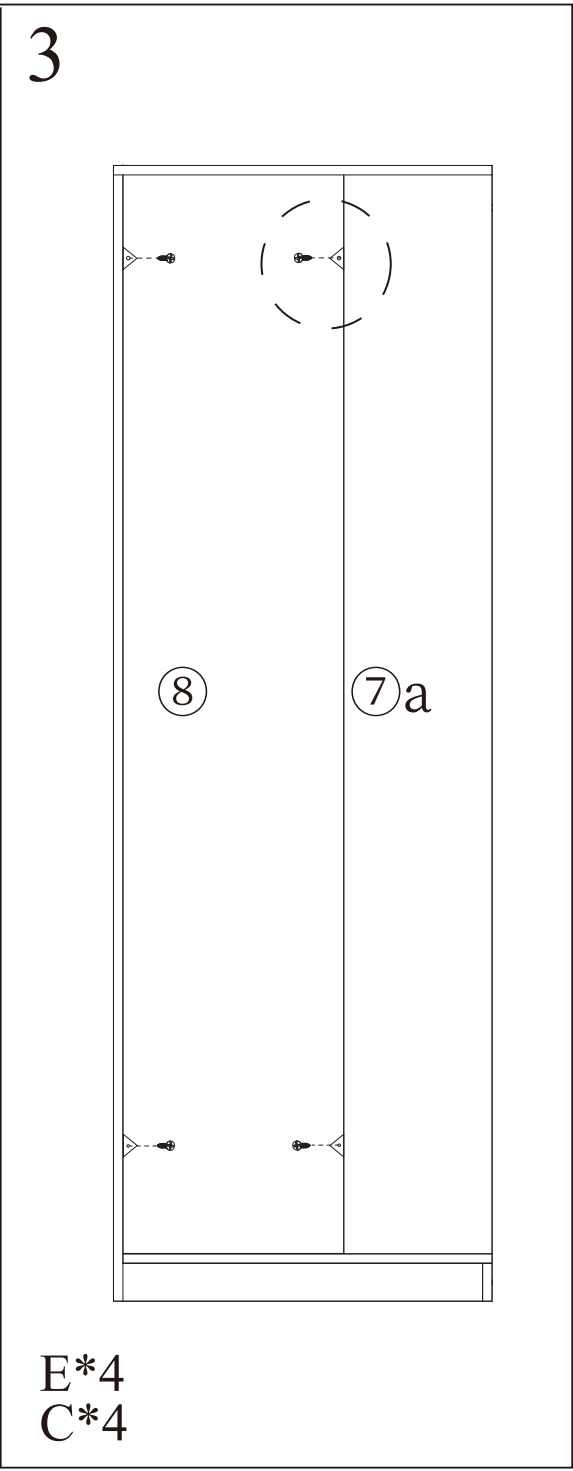
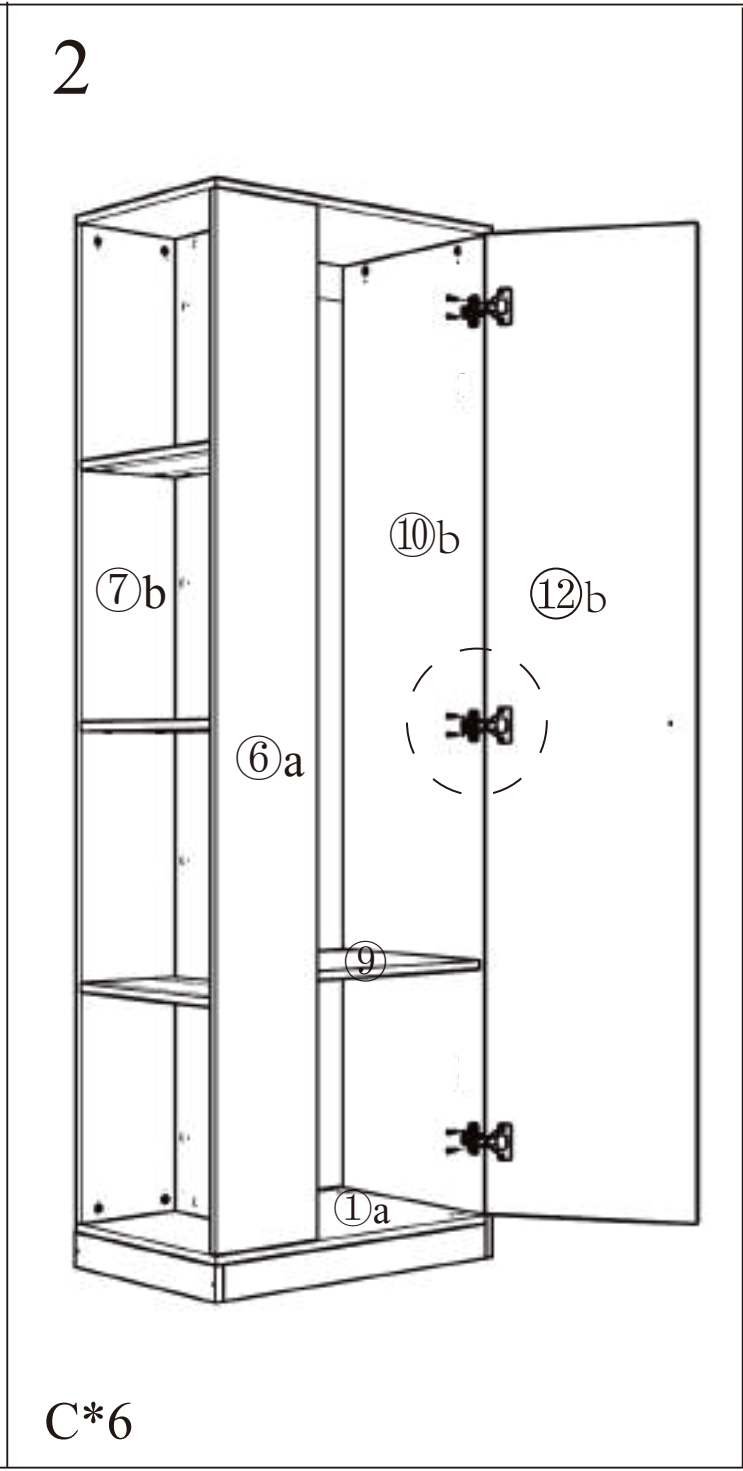
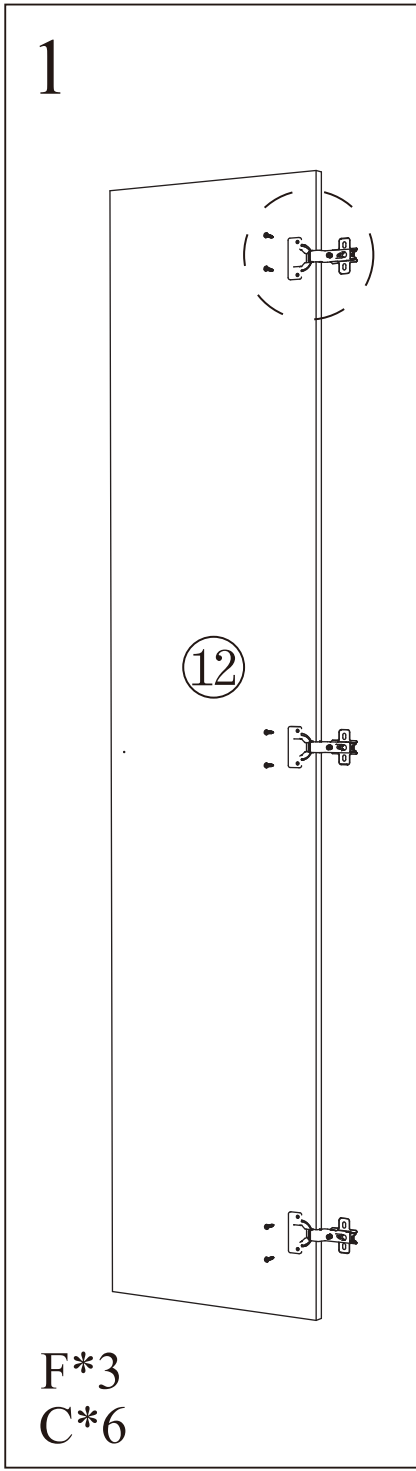

	E*4
	F*3
	C*16

Ø 3.5*14

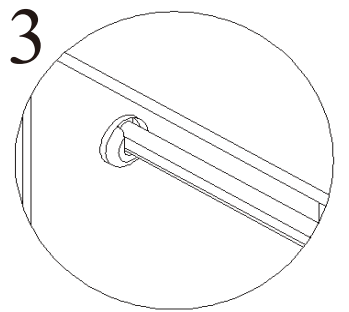
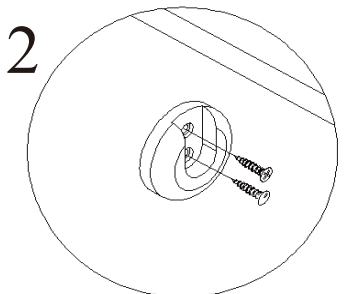
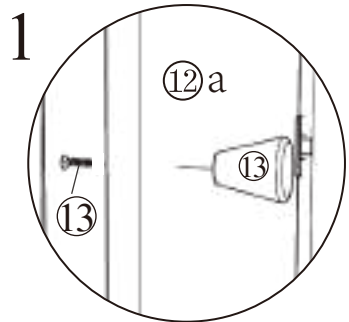

STEP 10



 $\varnothing 4 \times 20$	⑬*1
	H*1
	G1*2
 $\varnothing 3.5 \times 18$	G2*4

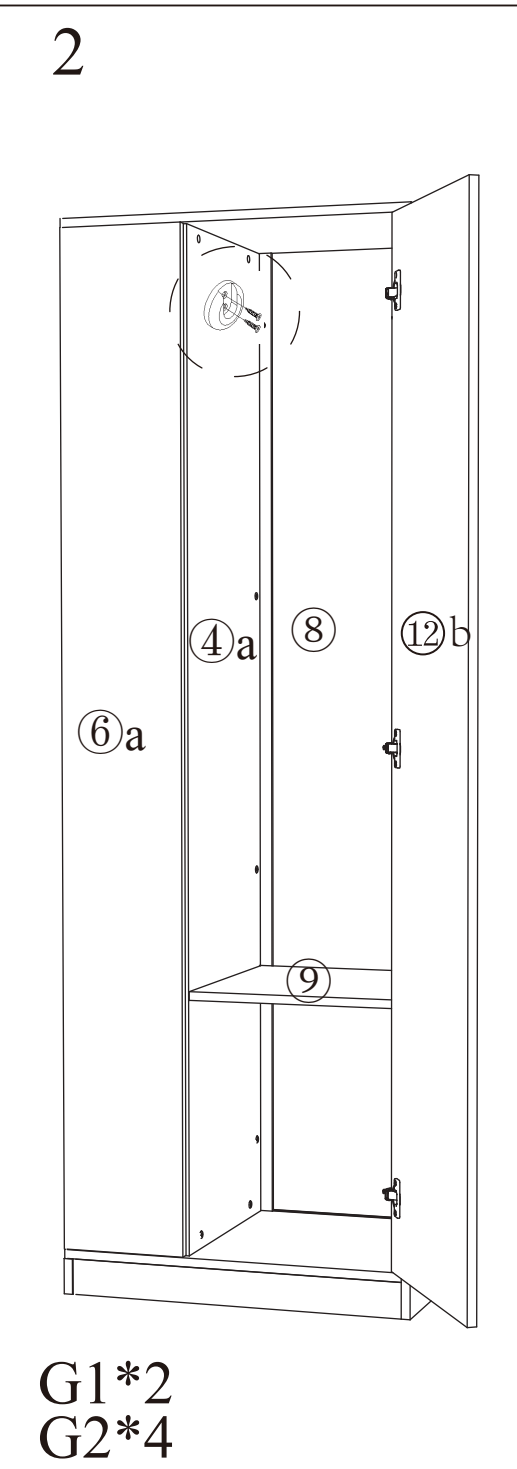
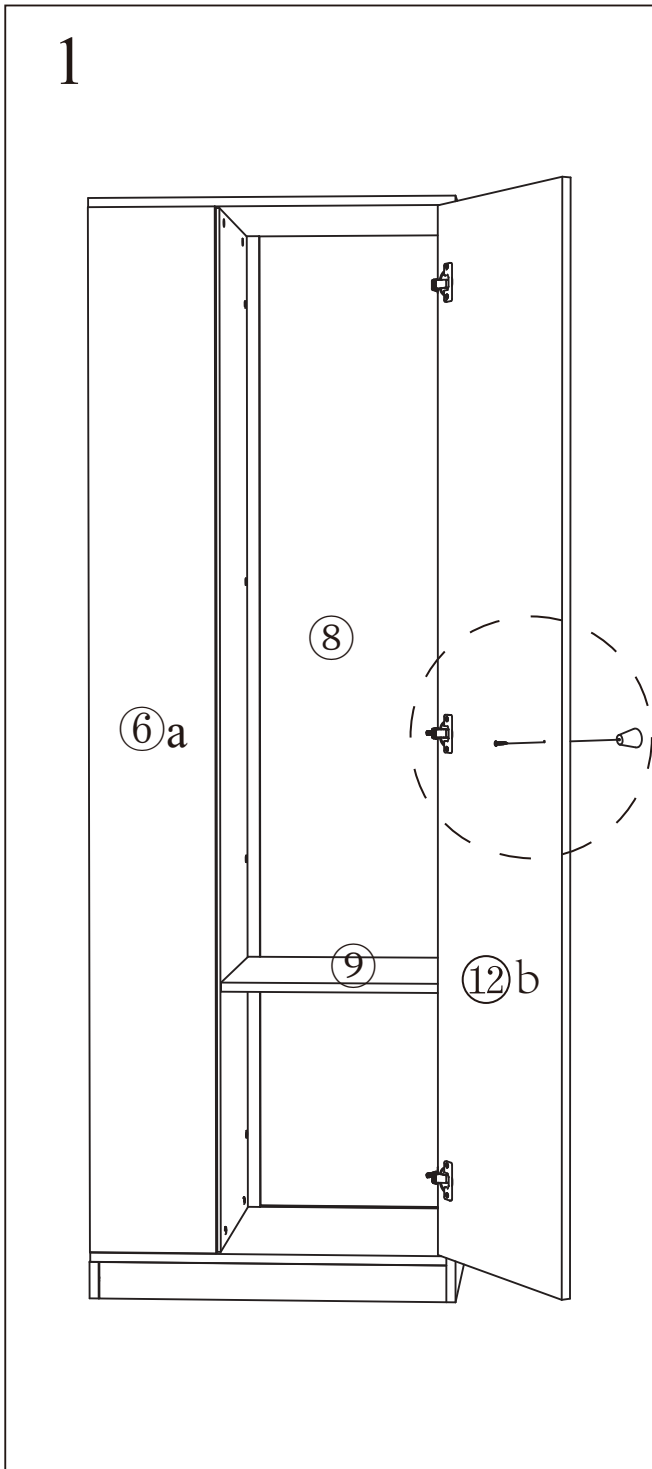

G1*2
G2*4

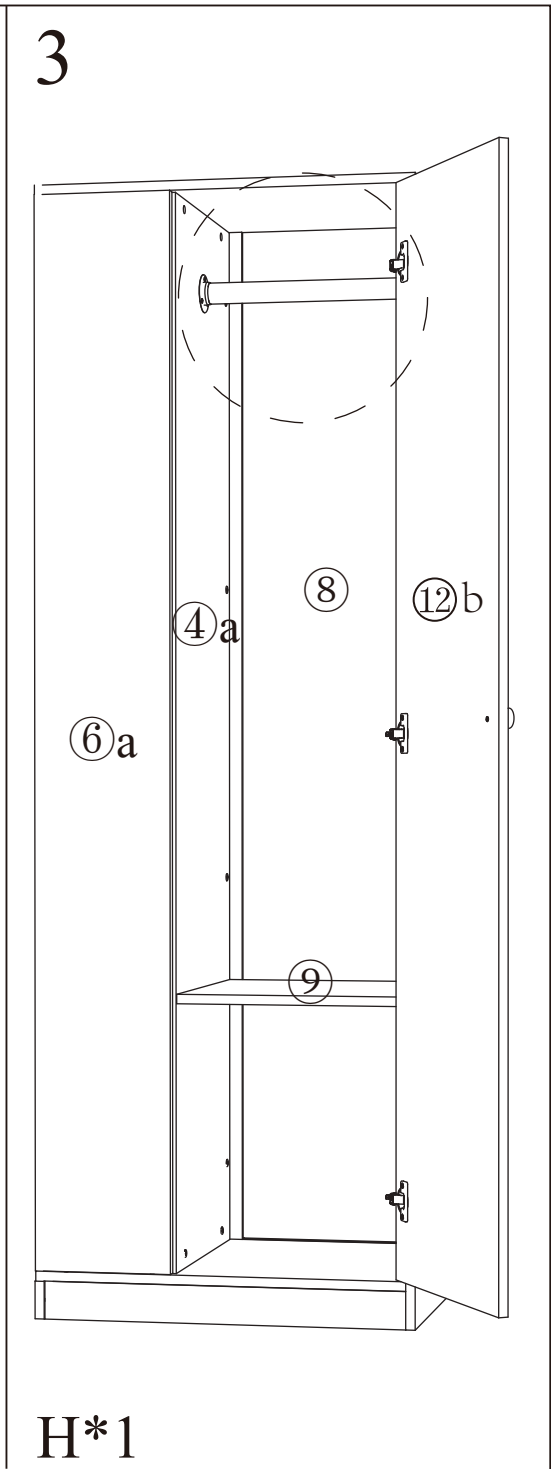



H*1

STEP 11

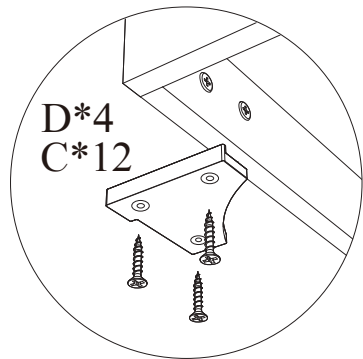
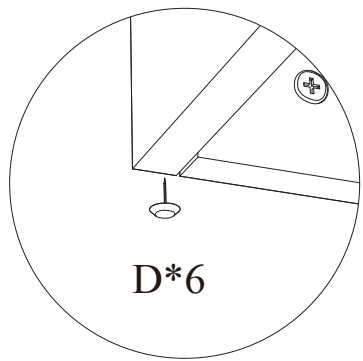
(Choose 1 of 2)

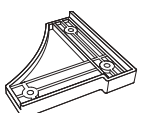

Option 1	
	D1*6
Option 2	
	D2*4
	C*12

Option 1

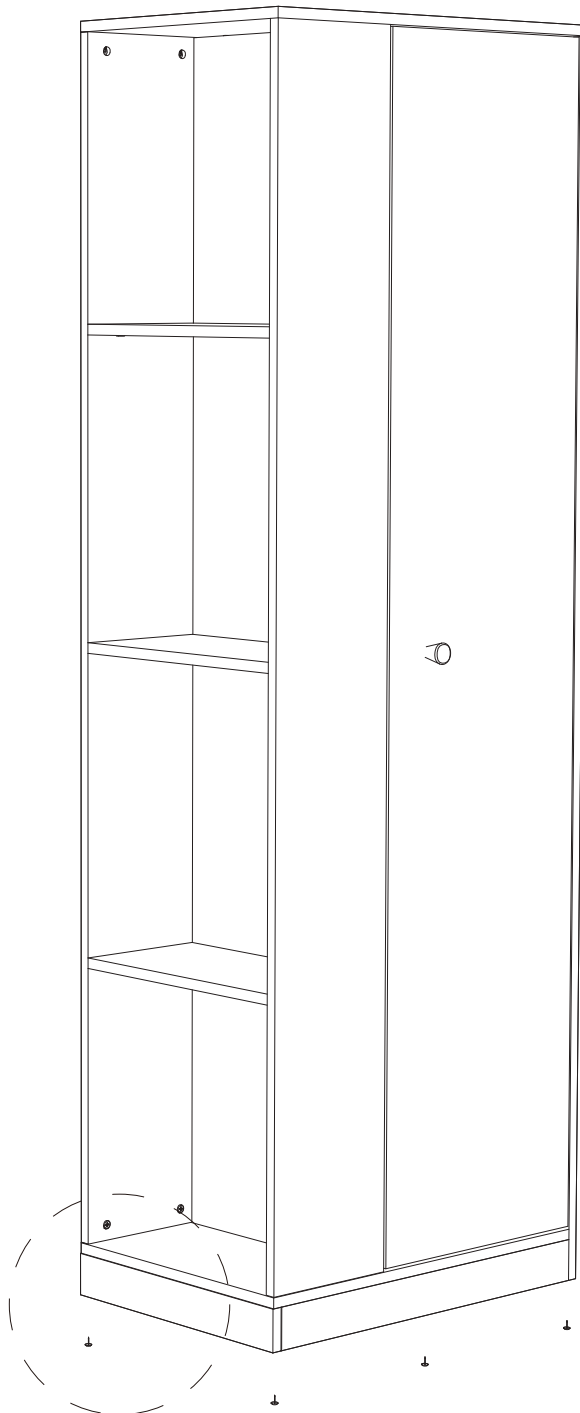

Option 2

