

# ASSEMBLY INSTRUCTIONS

## DINING TABLE

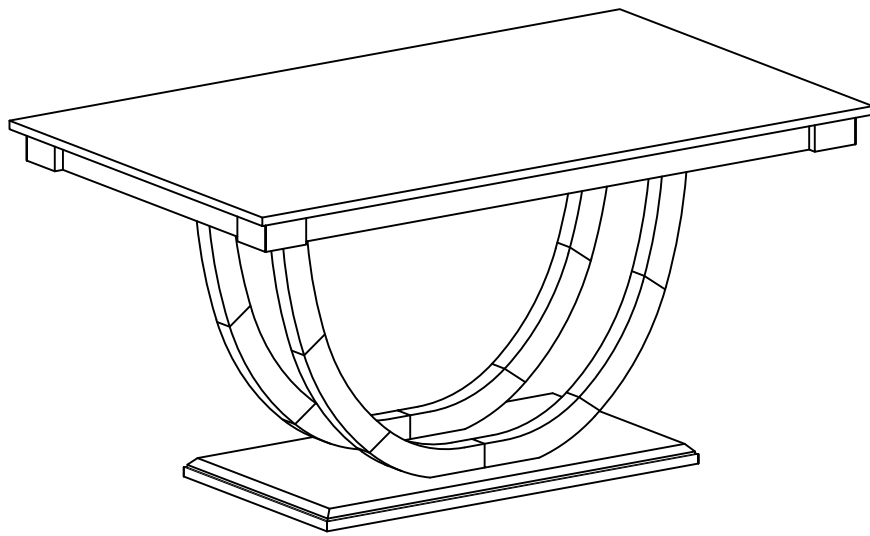

### IMPORTANT NOTE:

- PLACE ALL PARTS ON A CLEAN AND SMOOTH SURFACE SUCH AS A RUG OR CARPET TO AVOID THE PARTS FROM BEING SCRATCHED.
- BEFORE YOU BEGIN, KINDLY FOLLOW THE ASSEMBLY INSTRUCTIONS STEP BY STEP.
- DO NOT TIGHTEN ALL SCREWS AND BOLTS UNTIL THE TABLE IS FULLY SET-UP.

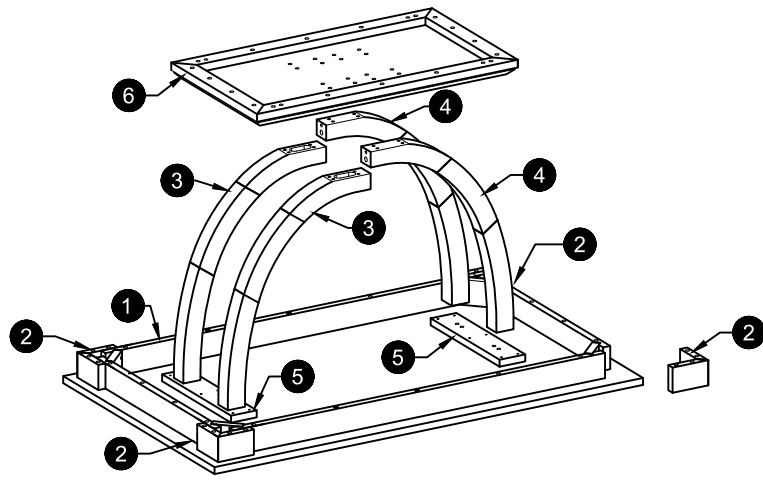

**CARTON CONTENT:**

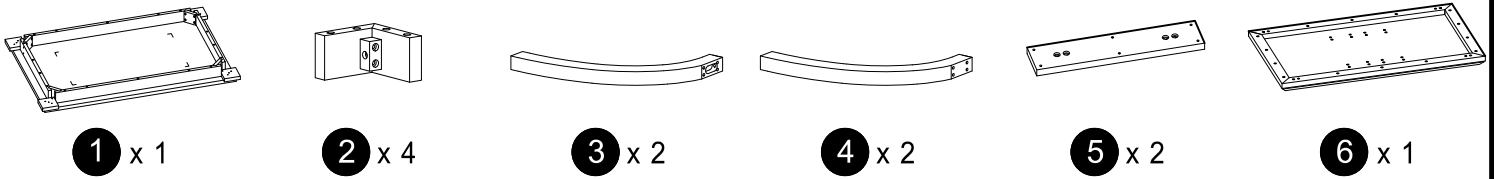
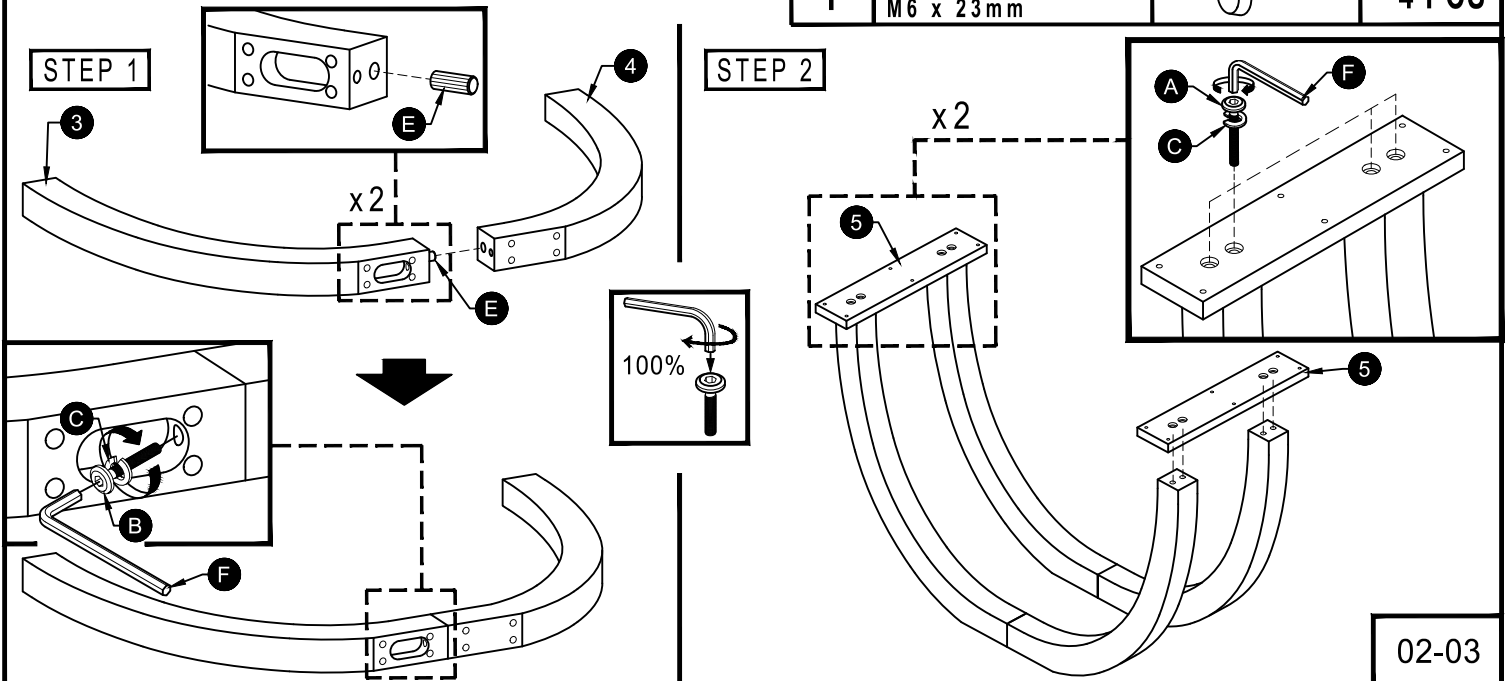

**TABLE PART LISTS**

NO.	DESCRIPTION	SKETCH	QTY
1	TABLE TOP		1 PC
2	APRON DECO		4 PCS
3	TABLE LEG ( L )		2 PCS
4	TABLE LEG ( R )		2 PCS
5	LEG SUPPORT		2 PCS
6	LEG BOTTOM		1 PC

**TABLE HARDWARE LISTS**

NO.	DESCRIPTION	SKETCH	QTY
A	JCBC BOLT M6 x 45mm		24 PCS
B	JCBC BOLT M6 x 60mm		2 PCS
C	SPRING WASHER 1/4"		26 PCS
D	FLAT WASHER 1/4"		16 PCS
E	WOOD DOWEL M12 x 30mm		2 PCS
F	ALLEN KEY M4		1 PC
G	C/B SCREW M4 x 30mm		12 PCS
H	C/B SCREW M4 x 50mm		16 PCS
I	ADJUSTER M6 x 23mm		4 PCS



STEP 3

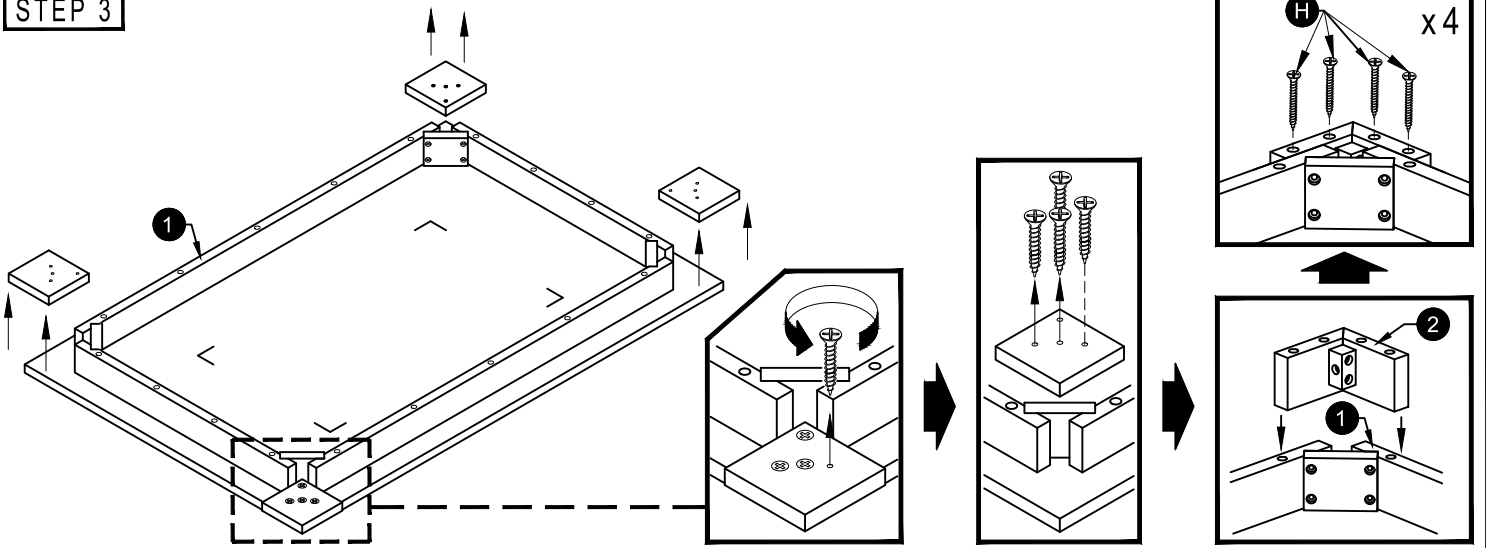

STEP 4

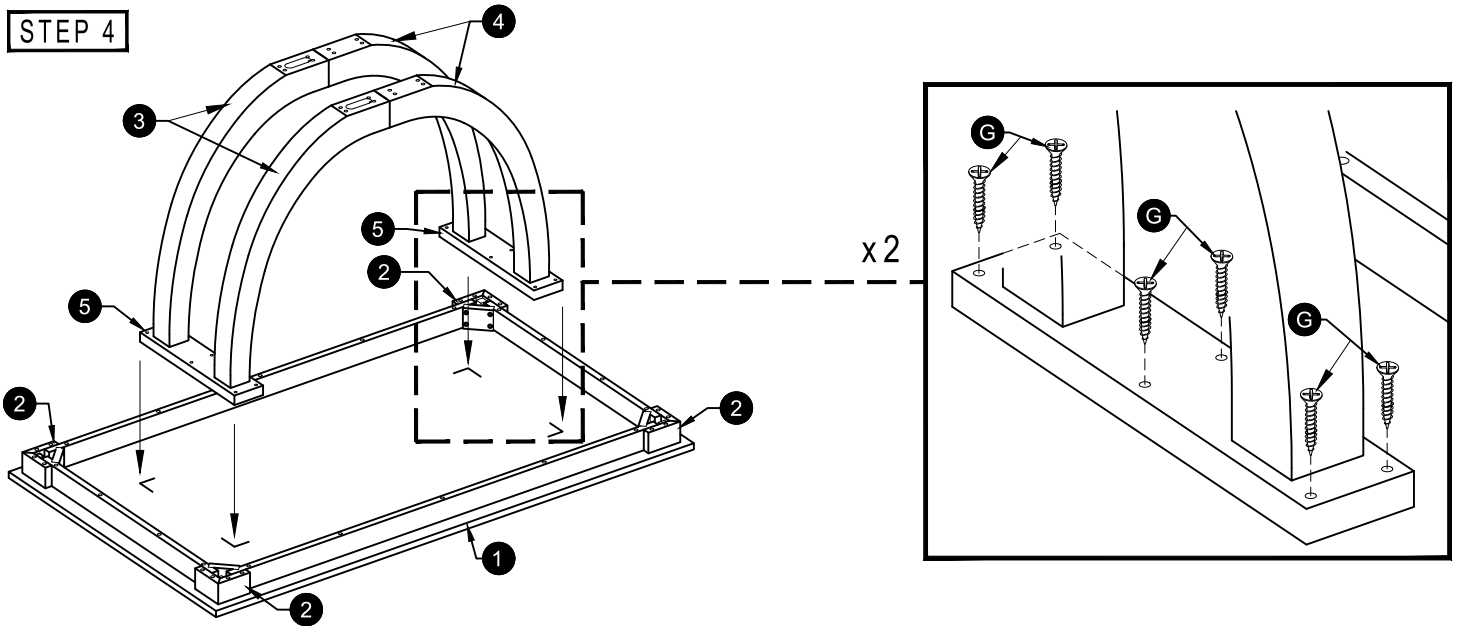

STEP 5

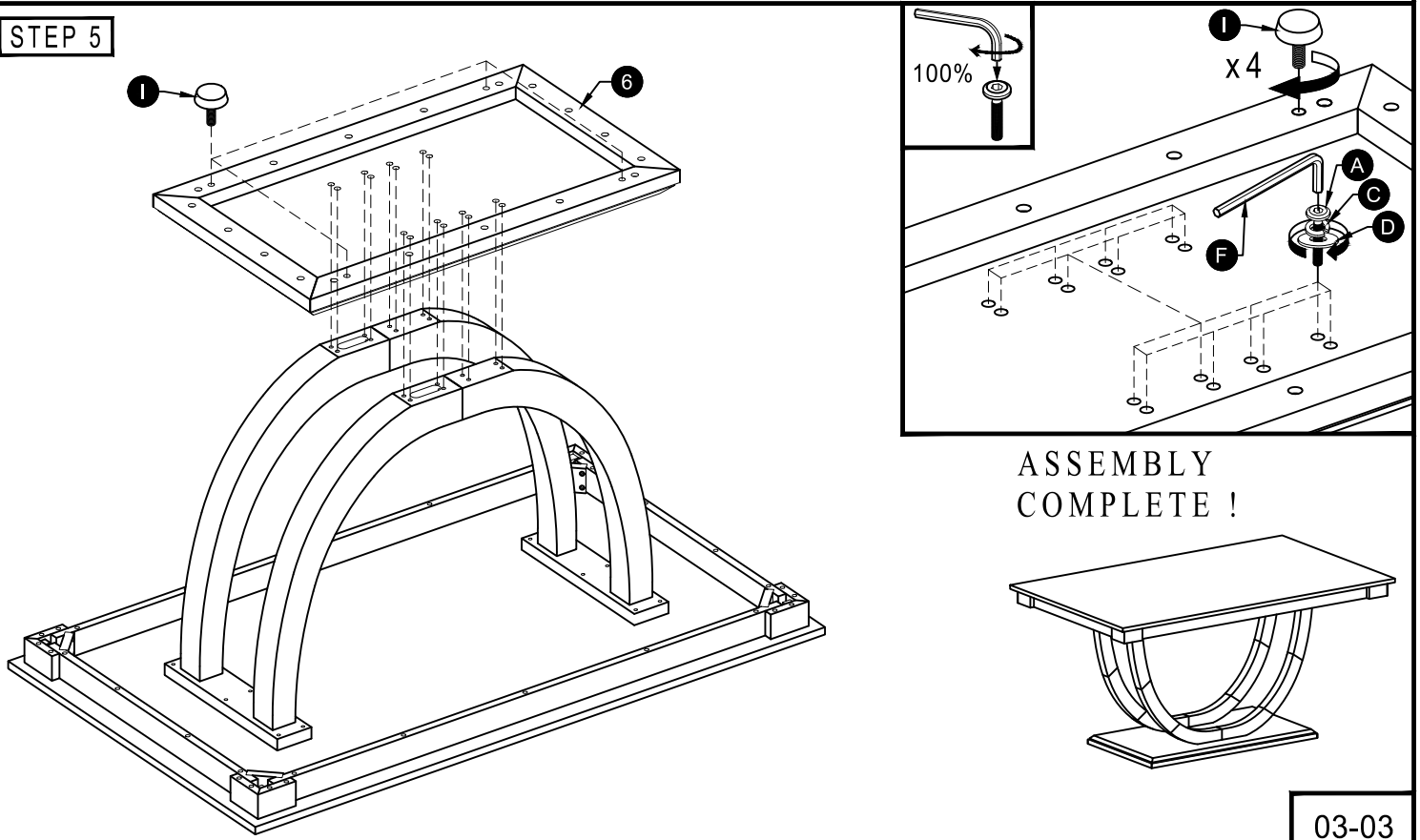

# ASSEMBLY INSTRUCTIONS

## DINING CHAIR

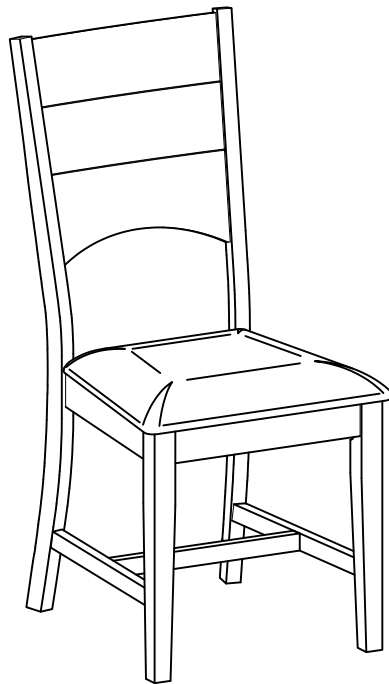

### IMPORTANT NOTE:

- PLACE ALL PARTS ON A CLEAN AND SMOOTH SURFACE SUCH AS A RUG OR CARPET TO AVOID THE PARTS FROM BEING SCRATCHED.
- BEFORE YOU BEGIN, KINDLY FOLLOW THE ASSEMBLY INSTRUCTIONS STEP BY STEP.
- DO NOT TIGHTEN ALL SCREWS AND BOLTS UNTIL THE CHAIR IS FULLY SET-UP.

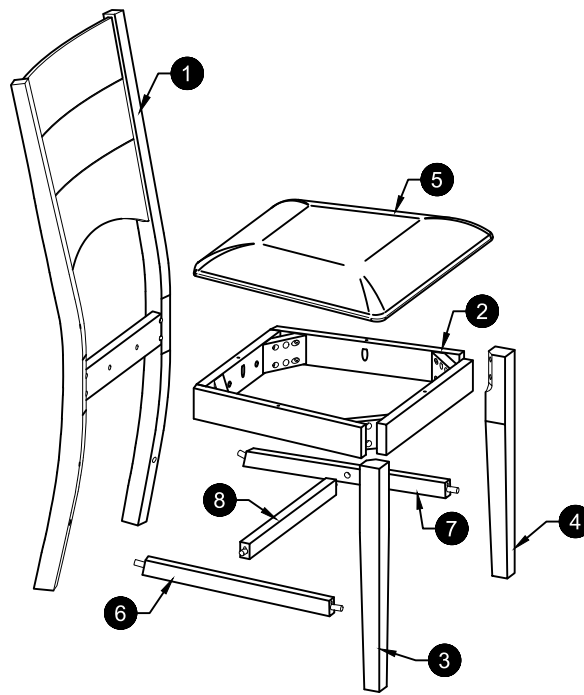

**CARTON CONTENT:**

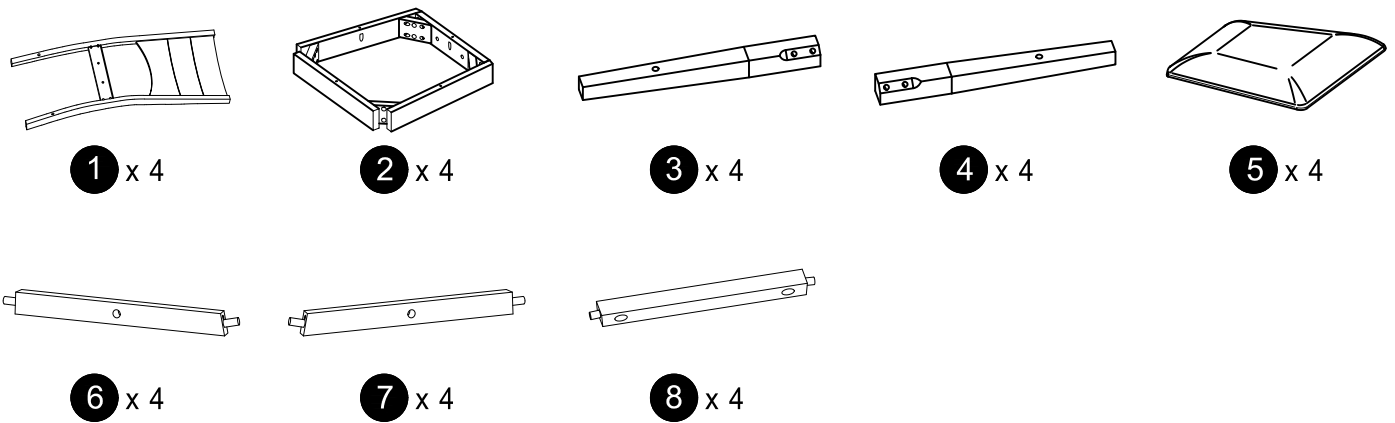

**CHAIR PART LISTS**

NO.	DESCRIPTION	SKETCH	QTY
1	BACK LEG		4 PCS
2	BOX SEAT		4 PCS
3	FRONT LEG ( L )		4 PCS
4	FRONT LEG ( R )		4 PCS
5	SEAT		4 PCS
6	STRETCHER ( L )		4 PCS
7	STRETCHER ( R )		4 PCS
8	STRETCHER ( M )		4 PCS

**CHAIR HARDWARE LISTS**

NO.	DESCRIPTION	SKETCH	QTY
A	JCBC BOLT M6 x 35mm		8 PCS
B	JCBC BOLT M6 x 60mm		16 PCS
C	JCBC BOLT M6 x 80mm		16 PCS
D	SPRING WASHER 1/4"		40 PCS
E	FLAT WASHER 1/4"		40 PCS
F	ALLEN KEY M4		1 PC
G	C/B SCREW M4 x 30mm		16 PCS
H	C/B SCREW M4 x 45mm		16 PCS
N	C/B SCREW M4 x 38mm		8 PCS

STEP 1

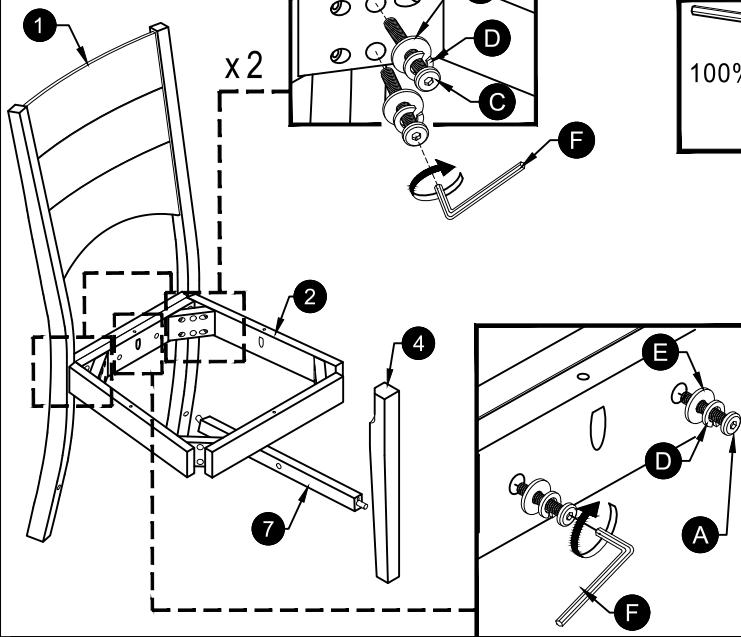

STEP 2

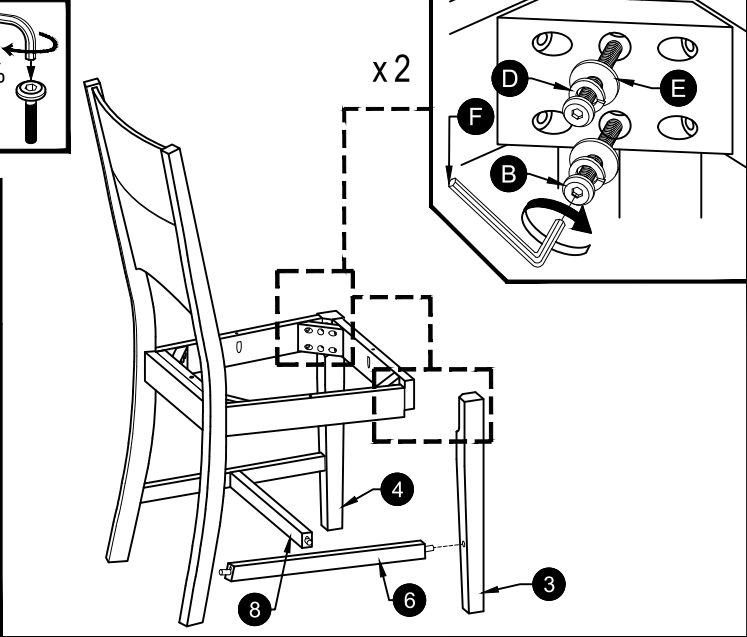

STEP 3

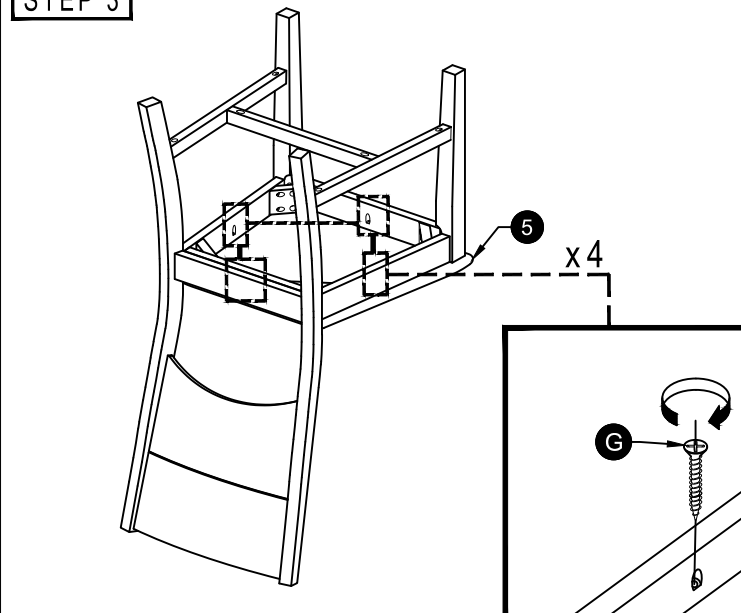

STEP 4

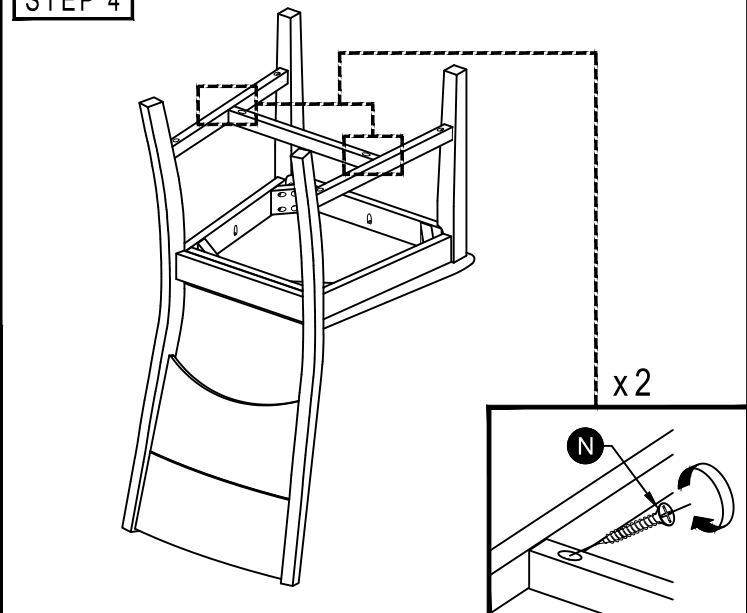

STEP 5

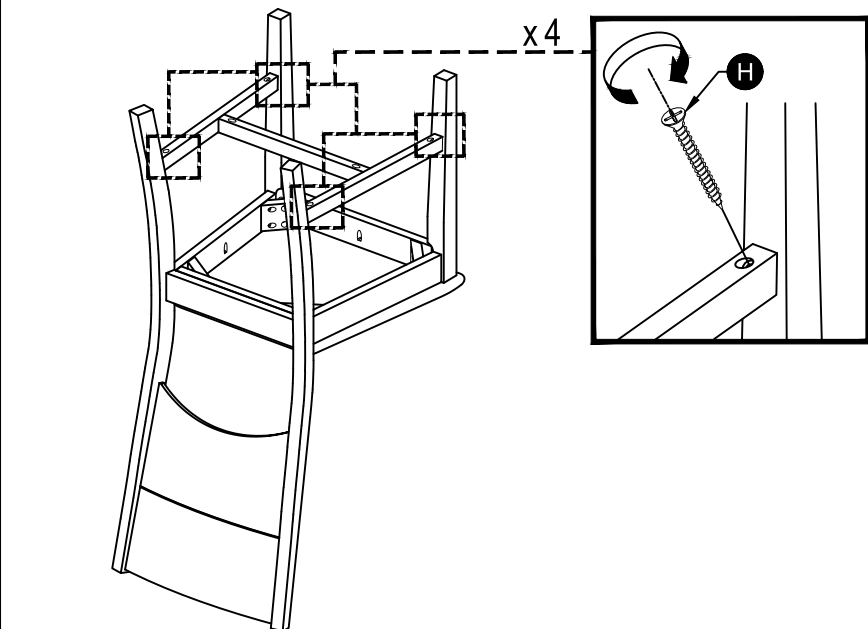

ASSEMBLY COMPLETE !

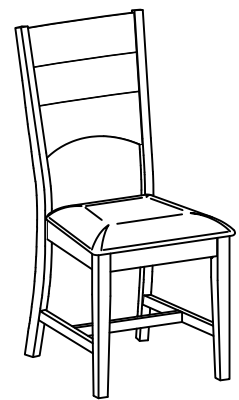

# ASSEMBLY INSTRUCTIONS

## DINING BENCH

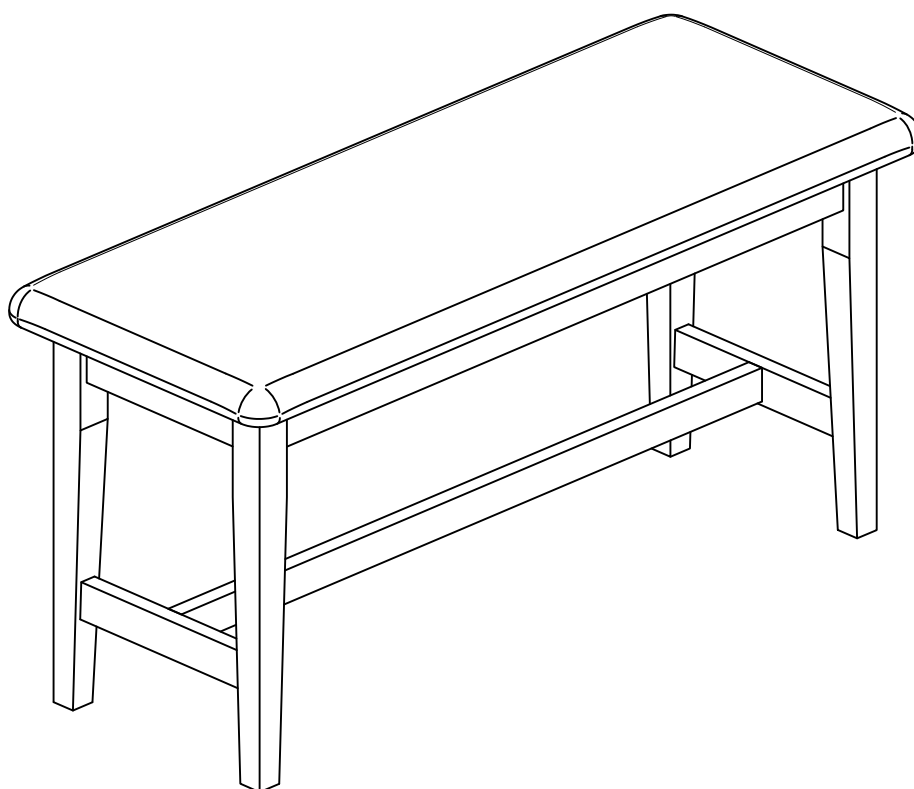

### IMPORTANT NOTE:

- PLACE ALL PARTS ON A CLEAN AND SMOOTH SURFACE SUCH AS A RUG OR CARPET TO AVOID THE PARTS FROM BEING SCRATCHED.
- BEFORE YOU BEGIN, KINDLY FOLLOW THE ASSEMBLY INSTRUCTIONS STEP BY STEP.
- DO NOT TIGHTEN ALL SCREWS AND BOLTS UNTIL THE BENCH IS FULLY SET-UP.

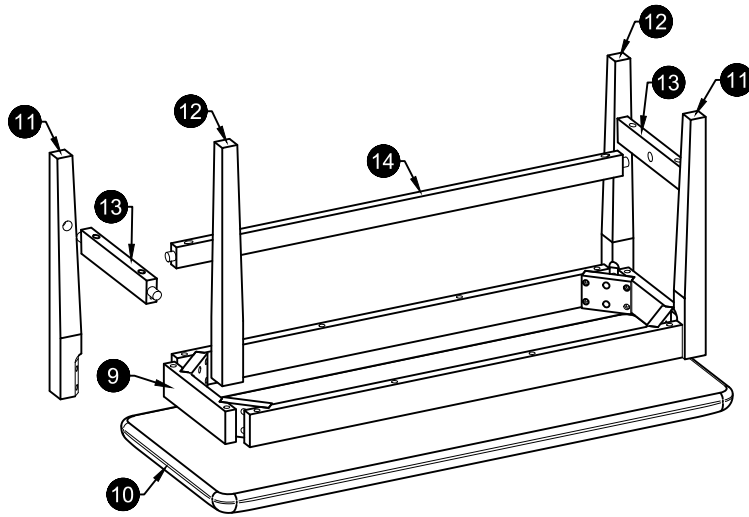

**CARTON CONTENT:**

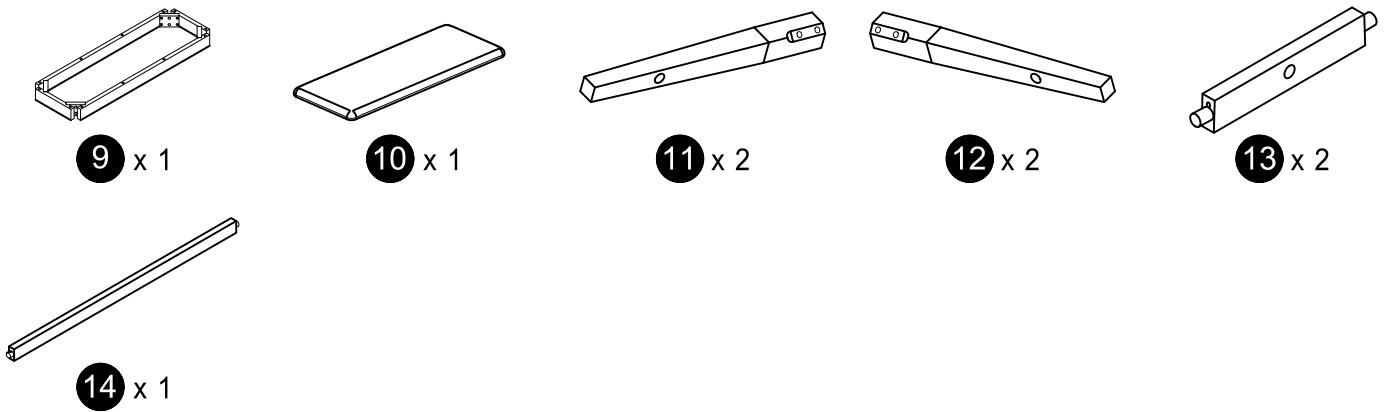

**BENCH PART LISTS**

NO.	DESCRIPTION	SKETCH	QTY
9	BOX SEAT		1 PC
10	SEAT		1 PC
11	LEG (L)		2 PCS
12	LEG (R)		2 PCS
13	STRETCHER (S)		2 PCS
14	STRETCHER (L)		1 PC

**BENCH HARDWARE LISTS**

NO.	DESCRIPTION	SKETCH	QTY
I	C/B SCREW M4 x 45mm		18 PCS
J	JCBC BOLT M6 x 70mm		8 PCS
K	SPRING WASHER 1/4"		8 PCS
L	FLAT WASHER 1/4"		8 PCS
M	ALLEN KEY M4		1 PC

STEP 1

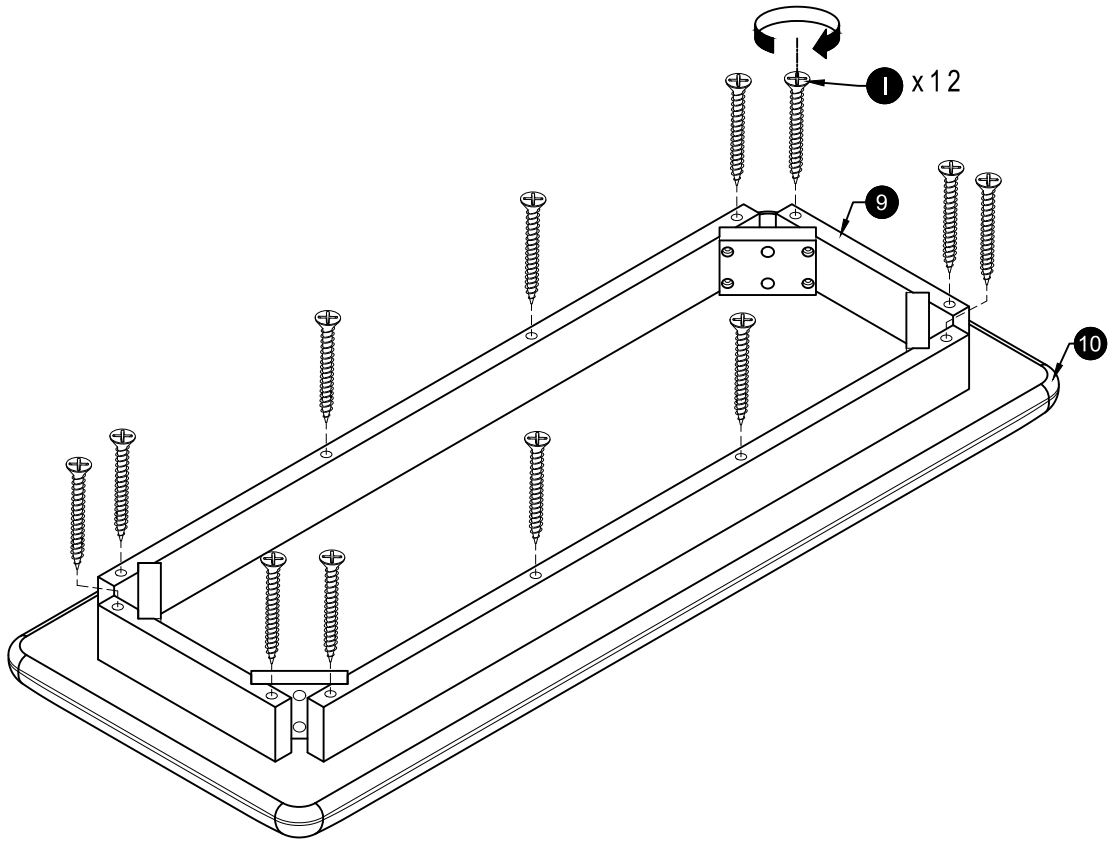

STEP 2

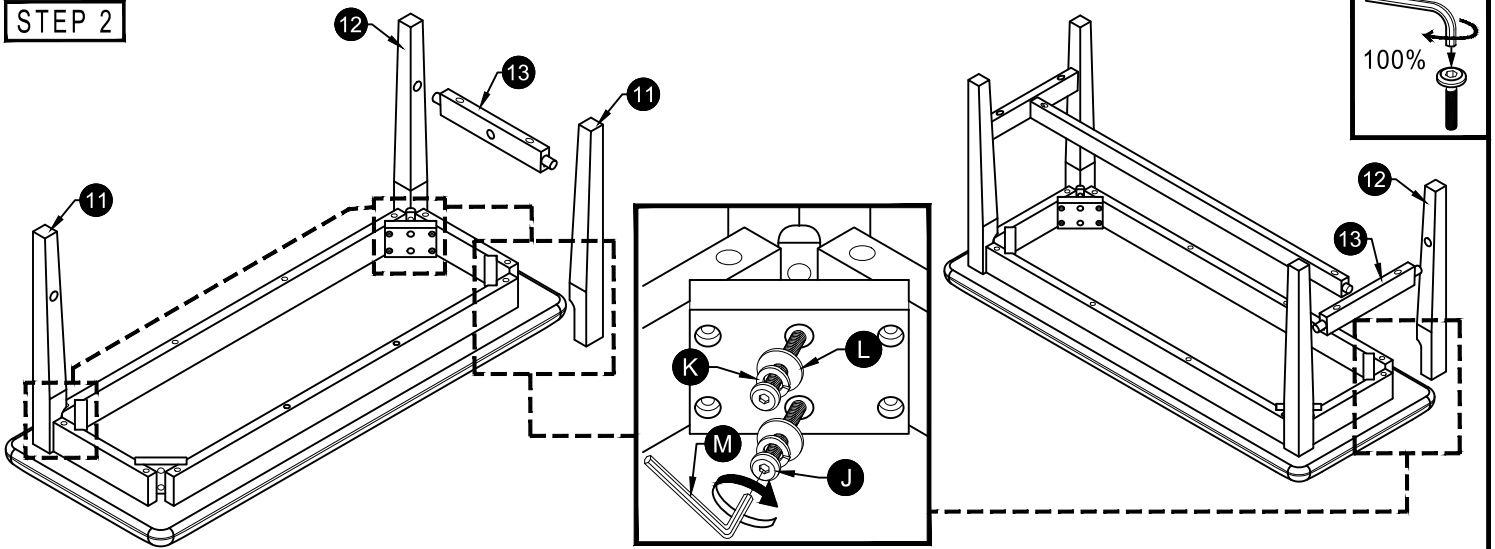

STEP 3

