

# Assembly Instructions

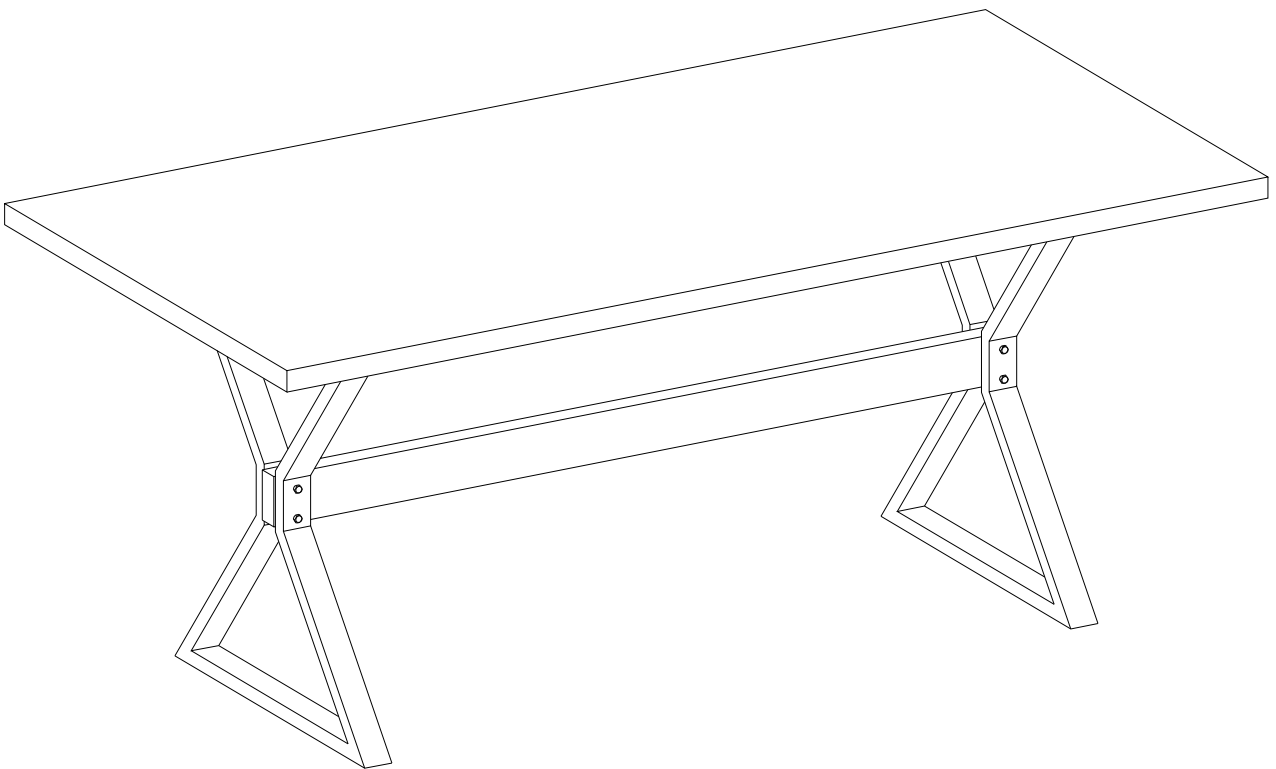

# General Assembly Guidelines

- I. Ensure that all parts and hardware are available before beginning assembly.
- II. Follow each step carefully to ensure the proper assembly of this product.
- III. Two people are recommended for ease in the assembly of this product.
- IV. The main type of hardware used to assemble this product are: bolts and screws.
- V. Power tools should not be used to assemble this product.

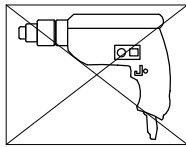





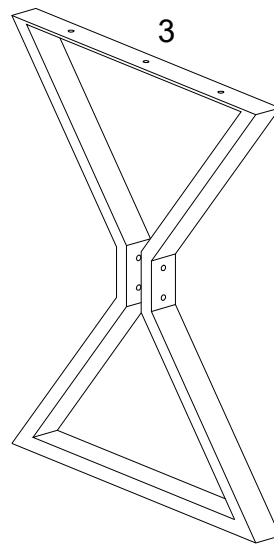
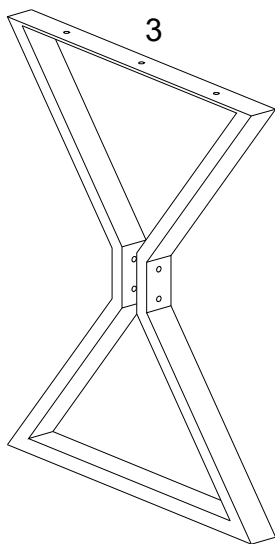
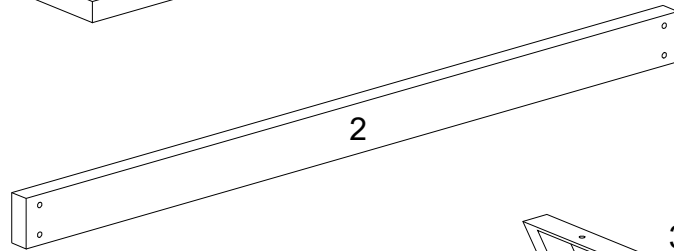
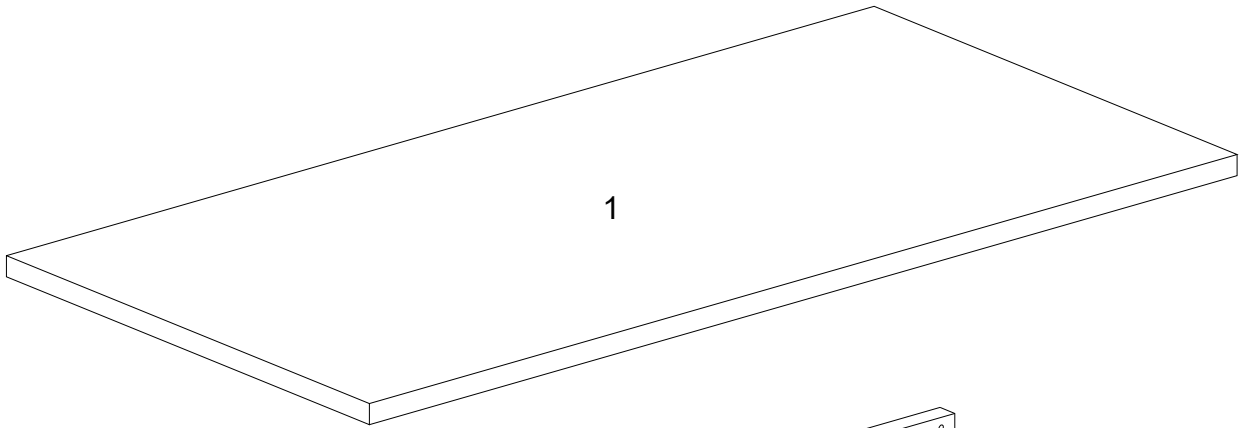

- VI. Drill may be needed for securing product to wall.

# Parts List



# Hardware List

A		M 8x40mm	Bolt	8 pcs
B		M 6x20mm	Bolt	6 pcs
C		1/4"	Lock washer	6 pcs
D		5/16"	Flat washer	14 pcs
E		M 12mm	Wrench	1 pc
F		M 4mm	Hex key	1 pc

*The hardware quantities listed above are required for proper assembly.  
Some extra hardware may also have been included.*

# Step 1

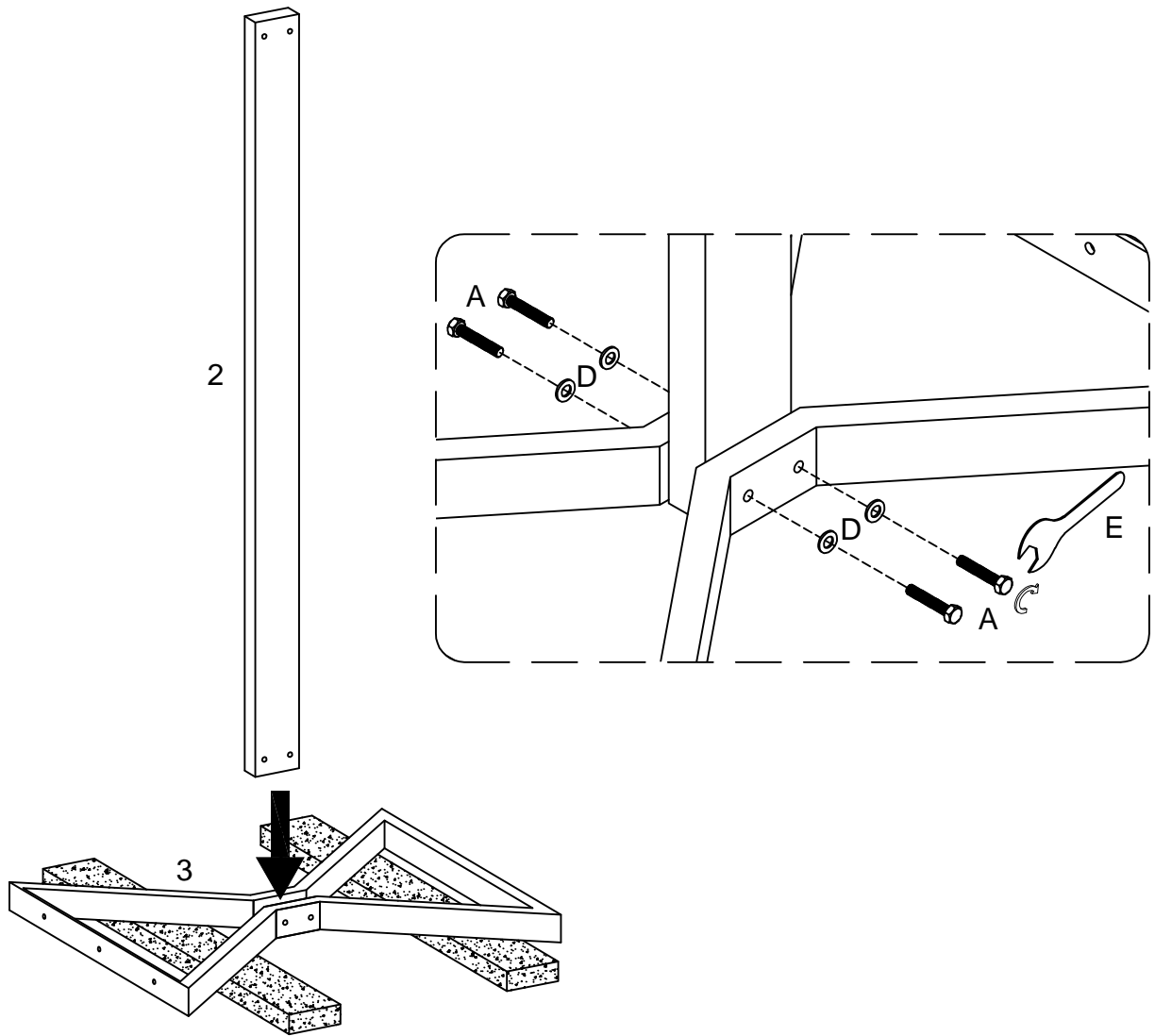

Insert part (2) to part (3) ,then using bolt (A) attach flat washer (D) into part (3) to part (2) with wrench (E) as per diagram.

Note:Please do not fully tighten all bolts.

## Step 2

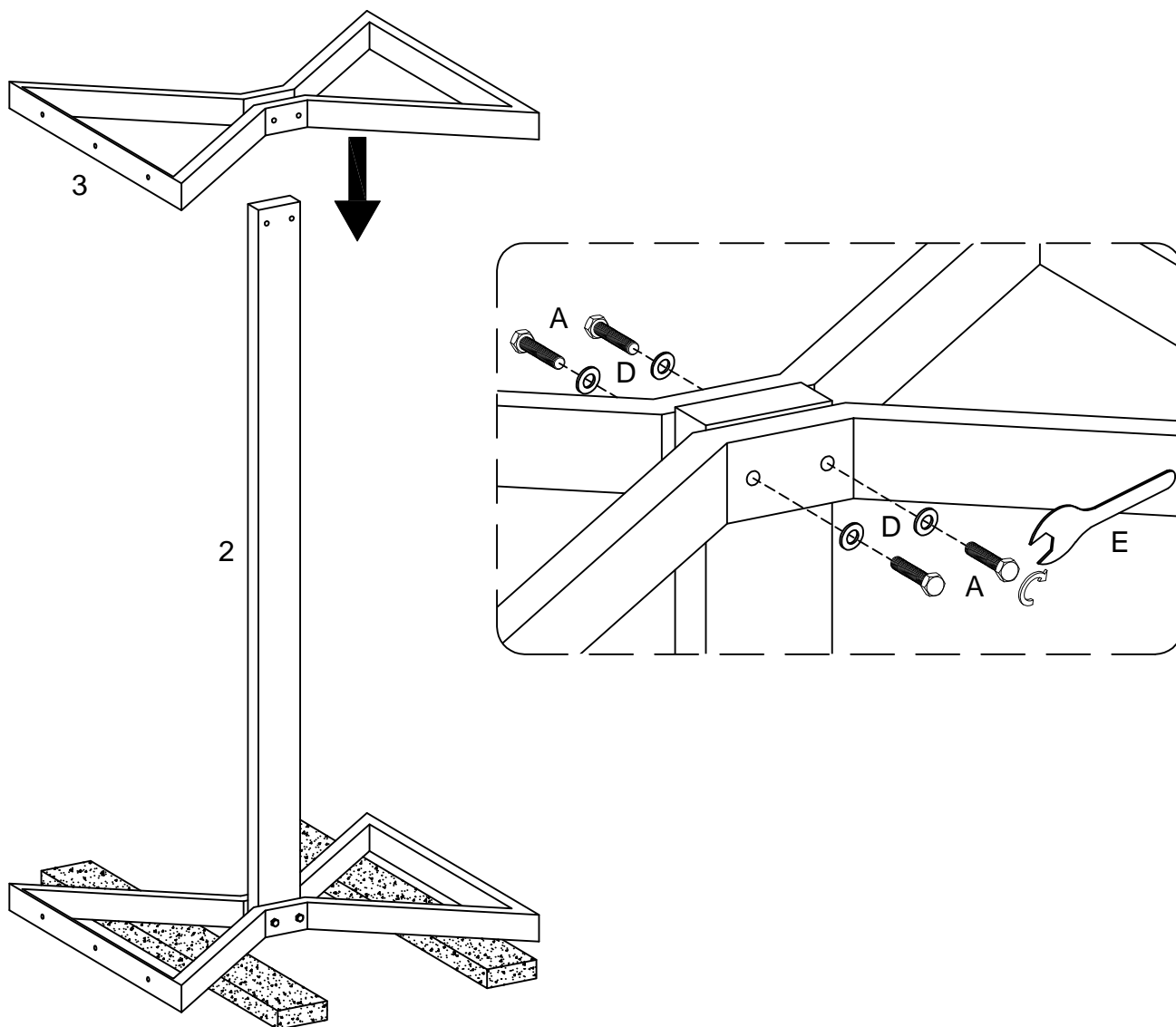

Place part (3) to part (2) ,then using bolt (A) attach flat washer (D) into part (3) to part (2) with wrench (E) as per diagram.

# Step 3

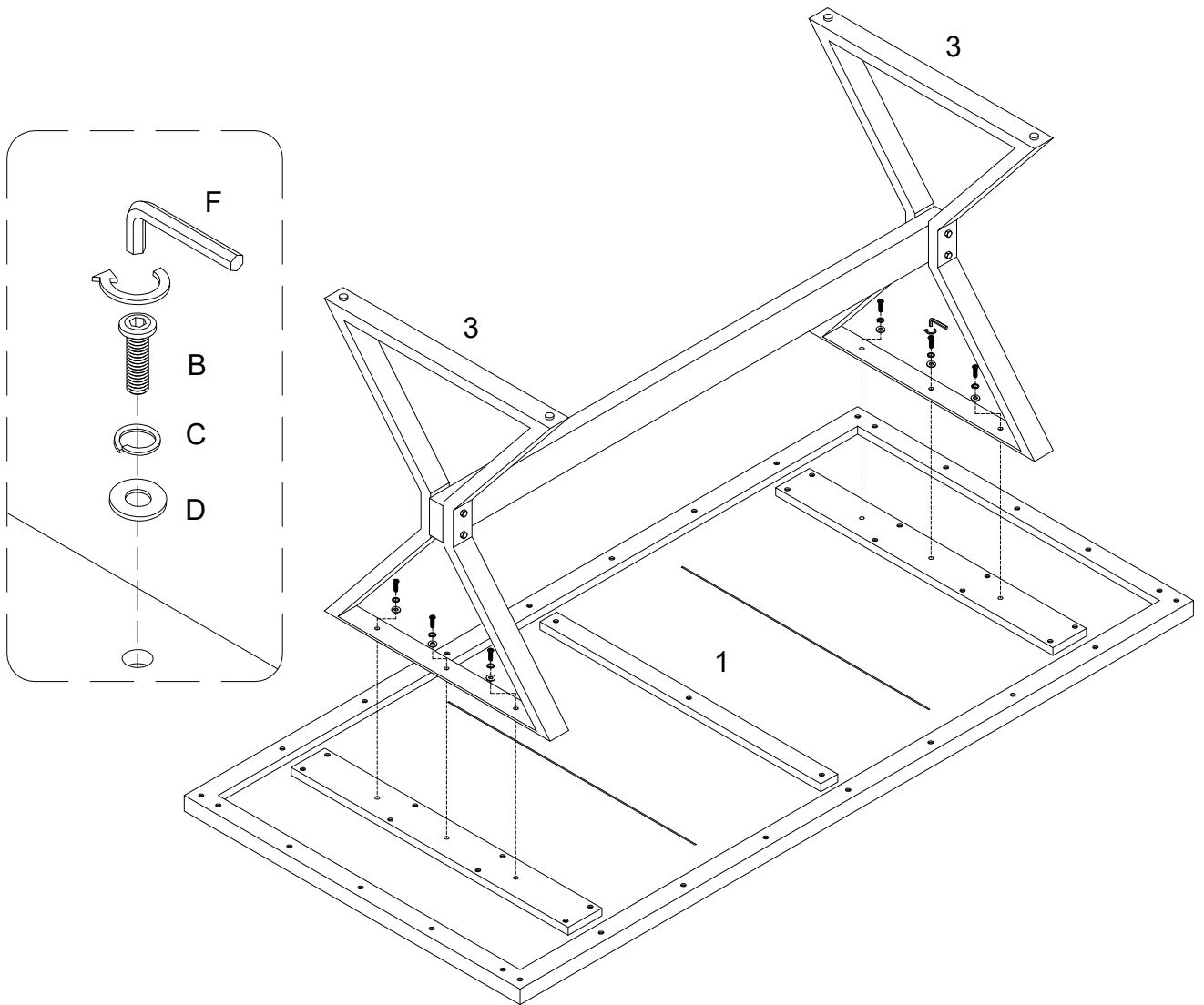

Using bolt (B) attach Lock washer (C) and Flat washer (D) into part (3) to part (1) with Hex key (F) as per diagram.

Note: Please fully tighten all bolts.

## Step 4

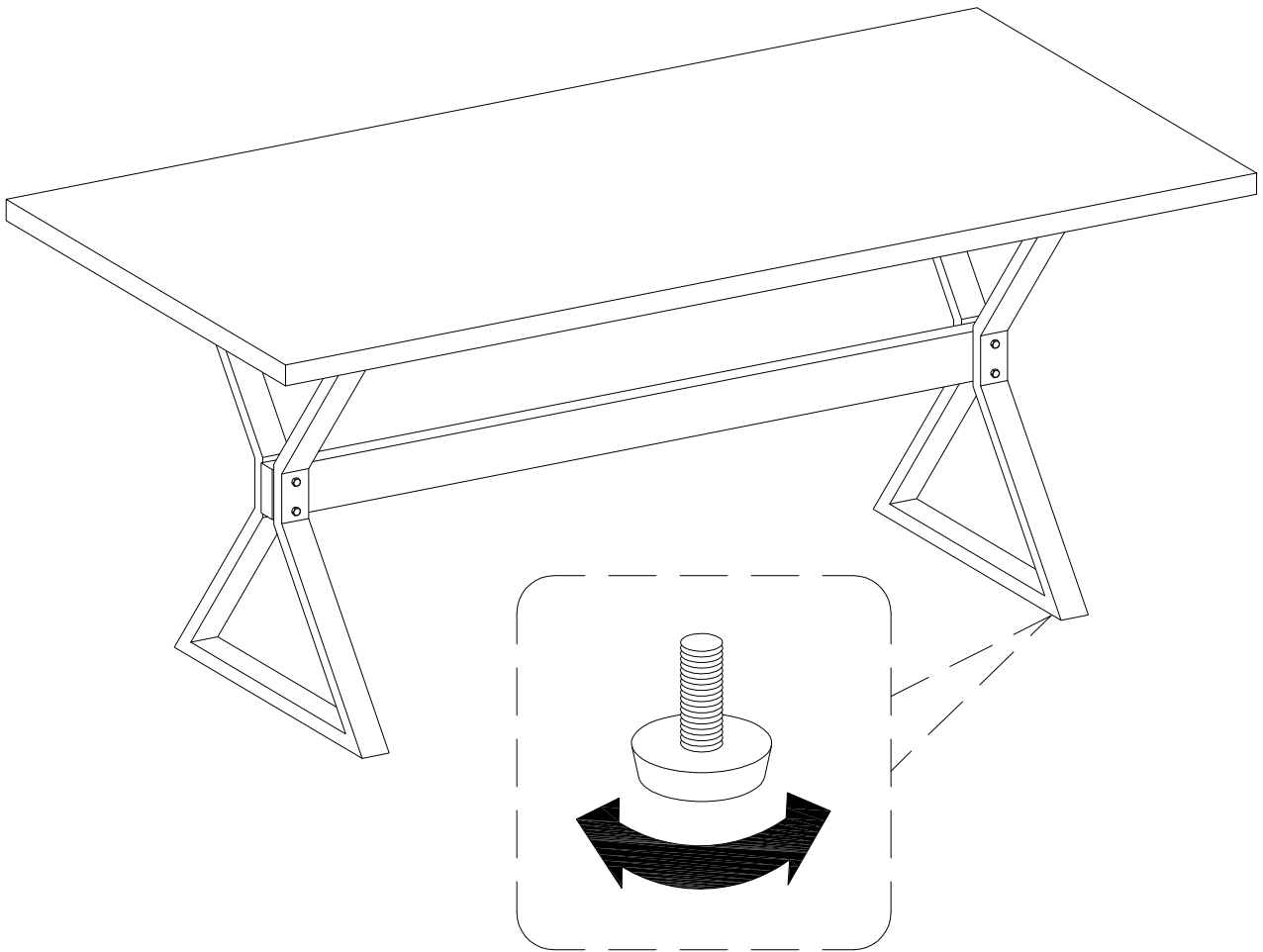

Position the assembled unit at the desired location ,if necessary adjust the floor leveler at the bottom of the leg to level the unit .

# Step 5

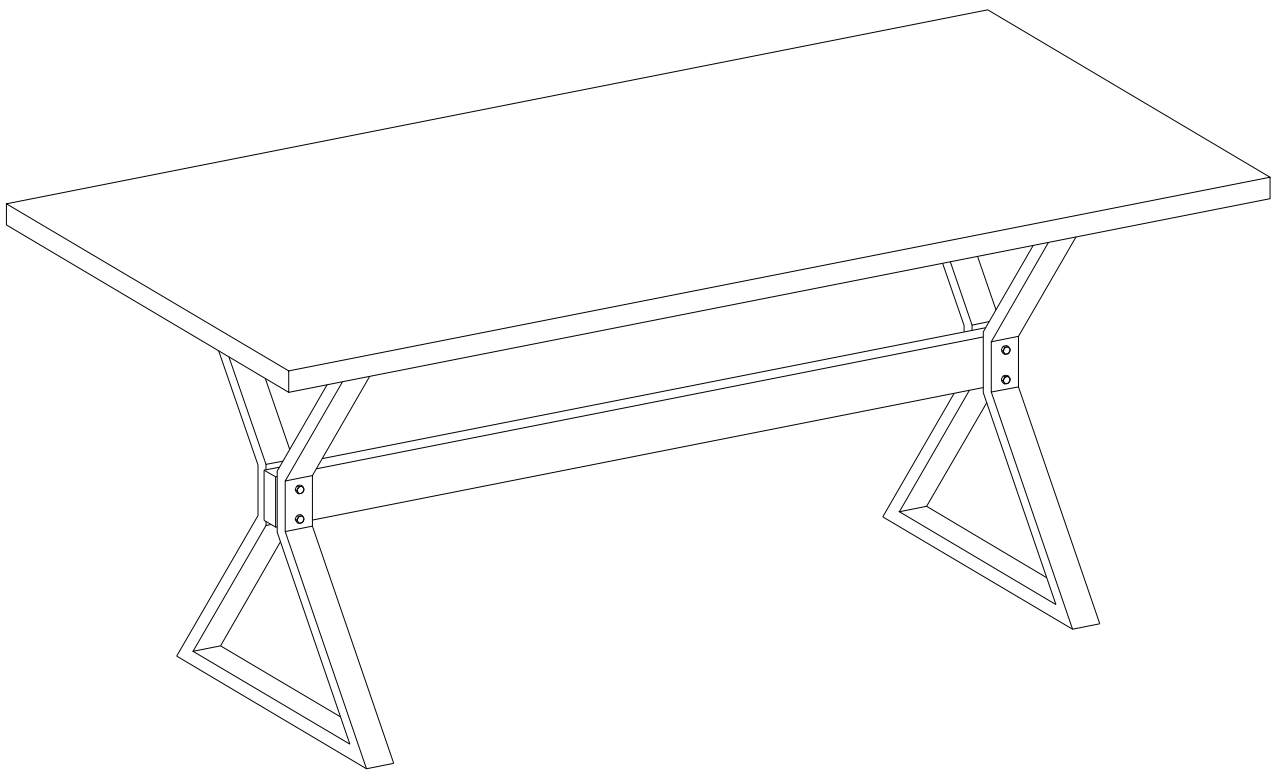

**Final Assembly**