

**These instructions are for your safety. Please read through them thoroughly before use .
PLEASE KEEP THIS LEAFLET FOR FUTURE REFERENCE**

Let's get started...



Important information...

Safety	03
Base and positioning	04
Warranty	04
Care maintenance & Recycling	05



In more detail...

Hardware chart	06
Parts List	07
Detailed Technical Drawing	08-09
Before you start	10
Assembly instructions	11-20

EN	For a copy of the instructions or a copy in another language please send an email or write to the address below.
F	Pour obtenir un exemplaire des instructions ou une copie dans une autre langue s'il vous plaît envoyez un e-mail ou écrire à l'adresse ci-dessous.
PL	Na kopii instrukcji lub kopii w innym języku prosimy o wysłanie maila lub pisać na adres podany poniżej.
RUS	Для получения копии инструкции или копия на другом языке, пожалуйста, отправьте по электронной почте или написать по указанному ниже адресу.
TR	Başka bir dilde talimatları veya bir kopyasını bir kopyası için bir e-posta gönderebilir veya aşağıdaki adrese yazınız.

Safety

Check that you have noted all the following instructions



- We advise the use of non slip protective gloves throughout the assembly process.
- We advise the use of steel capped protective footwear throughout the assembly process
- We advise that you use a helper to hold the glass in position whilst you nail the beading in place
- We advise the use of protective headwear and safety goggles throughout the assembly process
- Where a ladder is in use another person must hold the ladder.
- Do not attempt to work in windy conditions
- We advise the use of a scaffold tower when fitting the roof , for felting or if you cannot reach from the ground.
- Do not allow children near the tools and work area
- Follow any safety precautions quoted by the manufacturer for any equipment you use
- Check all parts before assembly
- Only use child and animal safe wood preservative
- Do not use creosote
- Allow the wood preservative to fully dry before use
- Regularly check the building for wear and tear

Important!



EVERY PRECAUTION IS TAKEN TO ENSURE THAT YOUR BUILDING HAS NO ELEMENT INCORRECTLY PLACED OR POSSIBLY HAZARDOUS, HOWEVER PRIOR TO USE PLEASE CHECK ALL SURFACES FOR THE FOLLOWING:

- (1) RAISED GRAIN, SPLINTERS: Sand down timber to smooth finish
- (2) NAIL/SCREW/PIN HEADS PROUD: Tap home to be flush with surface of timber
- (3) DAMAGED SCREW HEADS RESULTING IN SHARP SPLINTERS OF METAL: Replace
- (4) SHARP ENDS OF NAILS/ SCREWS/ PINS PROTRUDING THROUGH THE PANEL: Remove and reposition.
- (5) ENSURE ALL PARTS ARE SECURED AGAINST REASONABLE FORCE: Remove and refit
- (6) ENSURE THERE ARE NO LOOSE PARTS: Remove and refit/discard



IMPORTANT ! For your safety please read carefully the safety warnings

Preparation of base...

We recommend that the base onto which your building will stand should be at least 75mm larger in each direction than the total floor size of the building.

Actual floor area of the building: 2048mm x 1550mm

Total height clearance: 2160mm

Roof size 2200mm wide x1934mm long

The chosen position in your garden for your building should be excavated to a depth of 75mm to allow a base of sand, on to which paving slabs can be evenly laid.

You may also use an adjustable timber base or a concrete base. Whatever base you decide upon IT MUST BE LEVEL AND FIRM.

Warranty...

10 Year anti rot warranty subject to the following -

- The building must be raised so it is not in contact with any water retaining base surface (for example grass).
- This can be achieved using a timber, concrete or slab base
- When using a concrete or slab base use damp proofing strips under the bearers
- The building must have been completely treated and sealed immediately prior to or after assembly
- The building must have been re-treated and re-sealed annually
- If your building has been pressure treated or has any pressure treated parts additional treatment need not be applied (except for aesthetic purposes)
- Wood is a natural product and therefore the following are excluded from the warranty
 - Colour changes
 - Warping
 - Splitting

The following are also excluded

- Damage resulting from poor assembly
- Poor treatment application
- Poor care and maintenance
- Changes to the design
- Misuse
- General wear and tear

The 5 golden rules of care

- (1) Ensure your base is level and firm
- (2) Ensure the building is not sitting directly on the ground using damp proof membrane or the optional timber base.
- (3) Ensure every piece of timber and surface, especially that is hidden upon assembly is treated with a top quality wood preservative at least twice (see note on pressure treated buildings in warranty section). Turn the panels upside down whilst painting so the treatment runs into the seams.
- (4) Garden buildings are not waterproof, therefore we recommend you seal between all the panels with a silicone based sealant .
- (5) Regularly check your roofing felt for weather damage and leaks

The 7 golden rules of maintenance

- (1) Re apply the timber treatment annually. (see note on pressure treated buildings in warranty section)
- (2) Visually check for weather damage
- (3) Check and replace if necessary any Silicone sealant if used on your building.
- (4) Check the roofing material for wear
- (5) The doors and windows may require periodical adjustment
- (6) Ensure your building is well ventilated especially during hot weather
- (7) During extremely hot periods humidify your building to prevent the timber from drying out .



packaging

1. Pallet and timber widely recycled
2. Cardboard widely recycled
3. Plastic strapping subject to local regulations
4. Plastic sheeting subject to local regulations



Building

1. Timber widely recycled
2. Metal fixings widely recycled
3. Glass widely recycled
4. Roofing felt not currently recycled

Hardware Chart Scale 1:1

13mm Felt Nail
(A0023) x162



16mm Panel Pin
(A0024) x96

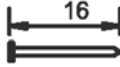

40mm Round head nail
(A0025) x130

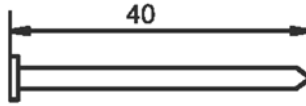

10mm Posi-drive screw
(A0028) 08



Black 25mm
Posi-drive screw
(A0031) x10

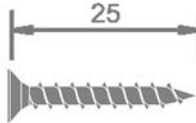

25mm Posi-drive screw
(A0032) x46

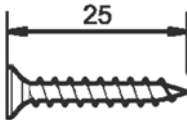

60mm Posi-drive screw
(A0035) 48

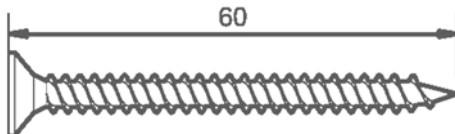

Description

(part No) qty

Fascia bag contents

Floor Joiners
(A0002) x06

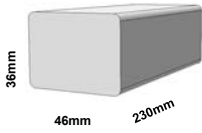

Door Hinges
(A0013) x06



Door Bolt
(A0014) x02



Gate latch set
(A0015) x01



Roof overhang
(A0011) x02

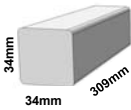

Fascia
(A0018)x04

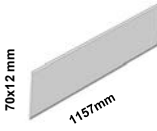

Diamond
(A0019) x02



Beading
(A0021) x24

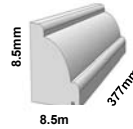

Beading
(A0022) x24

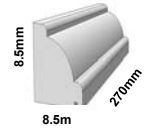

Stacked parts list

Doors
(A0012-L& R) x01 Pair



Floor
(A0001) x01

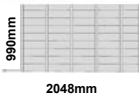

Floor panel
(A0003) x01

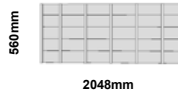

Plain Panel
(A0004) x04



Plain Panel
(A0005) x02

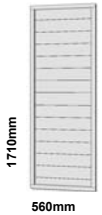

Plain Panel
(A0006) x02

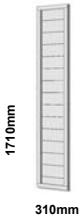

Gable Panel
(A0007) x02



Roof bearers
(A0008) x04

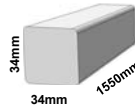

Roof panel
(A0009) x02

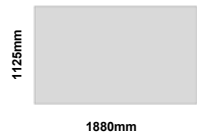

Roof edging
(A0010) x02

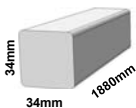

Cover strips
(A0016) x07

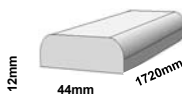

2.1m Felt strips
(A0017) x03

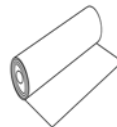

Glazing
(A0020) x12

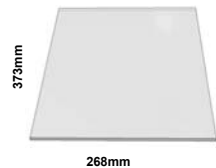

In more detail.....

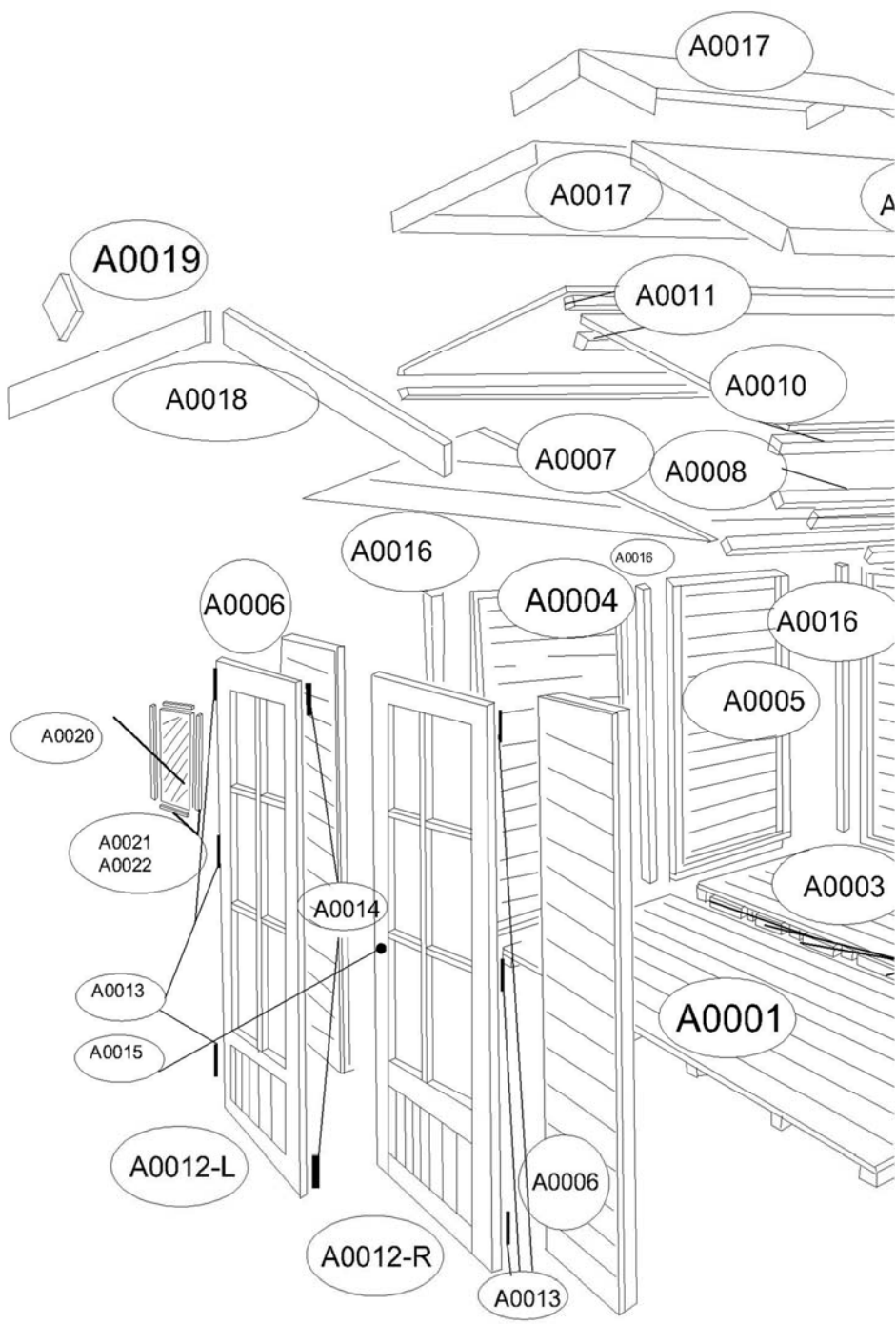

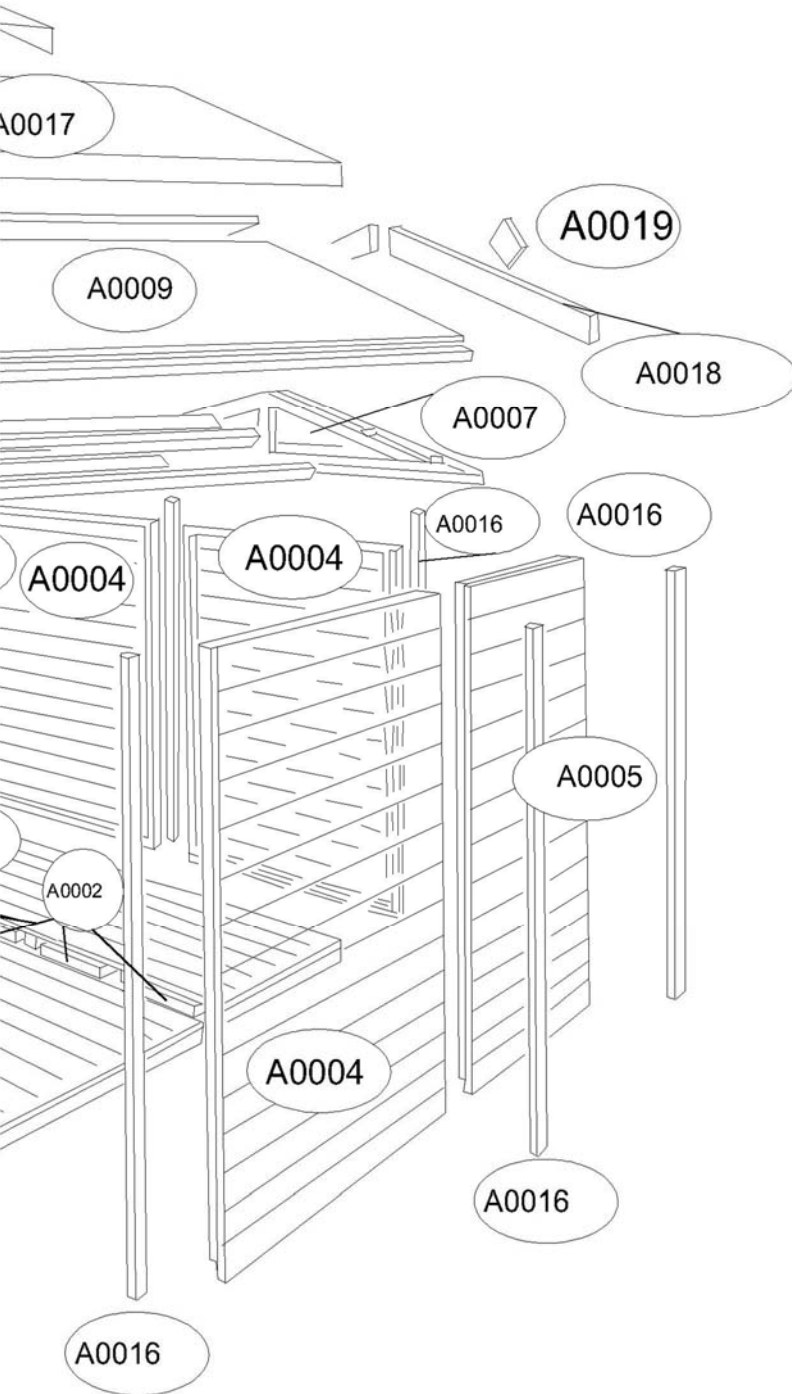

In more detail.....

Things to check before you start

- ✓ Ensure your base is ready– See page 3
- ✓ Check all parts as listed in the parts lists
- ✓ Read the instructions fully before starting work
- ✓ Follow all the health and safety guidelines



When you see the drill icon
 Only ever drill through the first piece of framework which will be a pilot hole for the screw to attach the second piece of framework
The required drill bit size is shown with the icon.

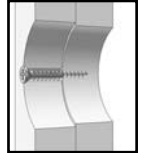
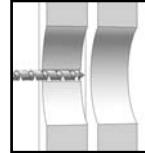

You will need



- Hammer



- Spirit level



- Ladder



- 1mm, 3mm 5mm & 8mm drill bit



- Drill

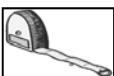

- Tape measure & Ruler

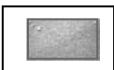

- Sand paper



- Gloves



- Saw

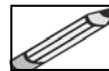

- Pencil



- Goggles



- A helper for some tasks



- Screwdriver



- Sharp knife

Assembly

These instructions are for your safety. Please read through them thoroughly before use .
Treat all the parts before assembly –see page 5

GB-IE

Position floor joiners "A0002" widest side down ,evenly between the floors fix with 3 x 40mm nails through each floor into each block (6 per block).

01

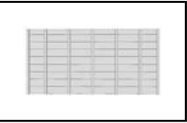

Floor panel
(A0001)x01



Floor panel
(A0003)x01

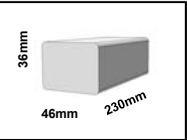

Floor Joiners
(A0002)x06

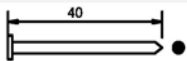

40mm Nails
(A0025)x36

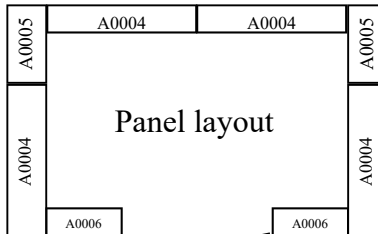
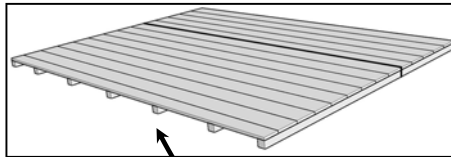
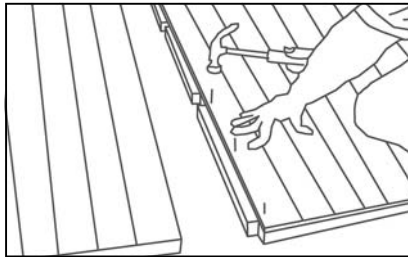
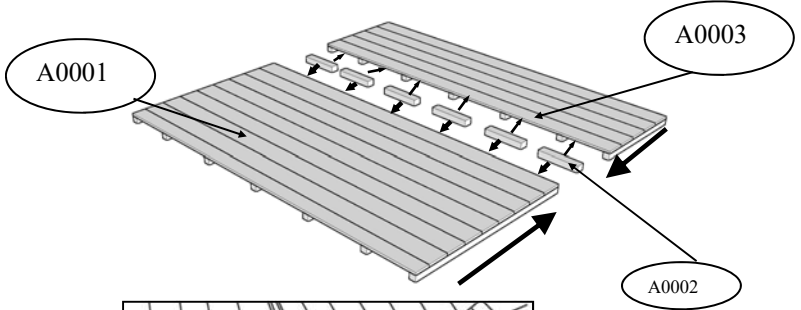

GB-IE

Doors go at the open end of the floor

The door end wall and the opposite end wall FIT INSIDE THE SIDE WALLS

02

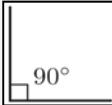

Plain Panel (A0004) x01

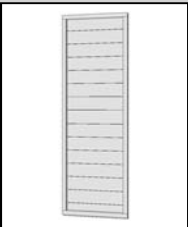

Plain Panel (A0005) x01



60mmScrew (A0035)x03

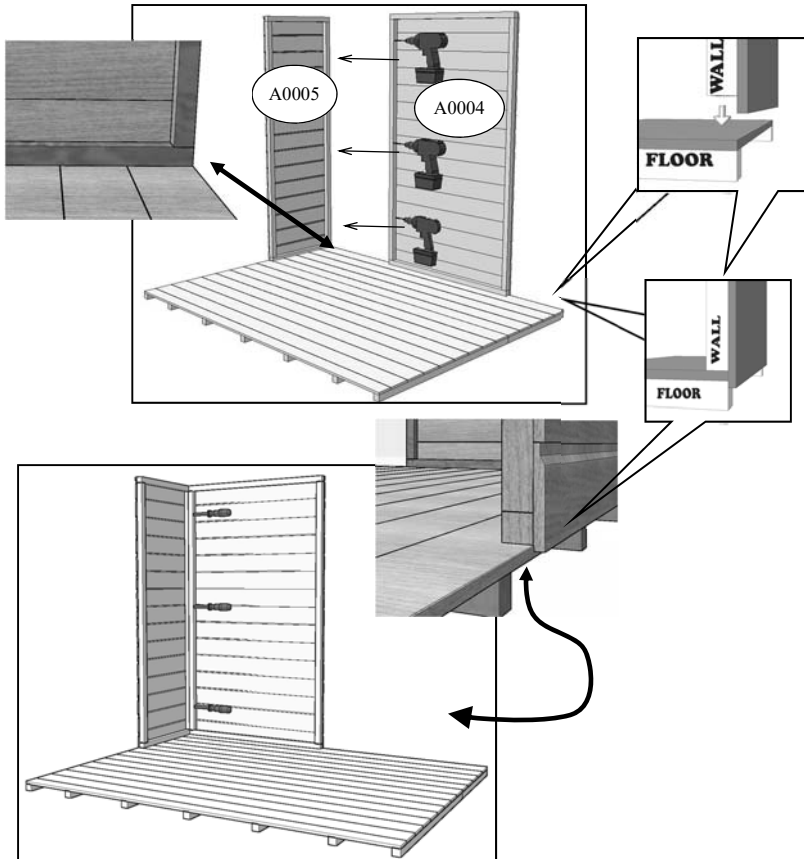

03

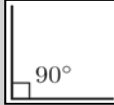

Plain panels
(A0004) x03

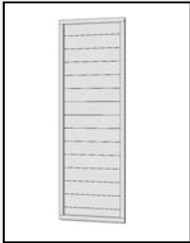

Plain panel
(A0005) x01



Plain Panel
(A0006) x02

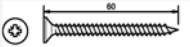

60mm Screws
(A0035) x18

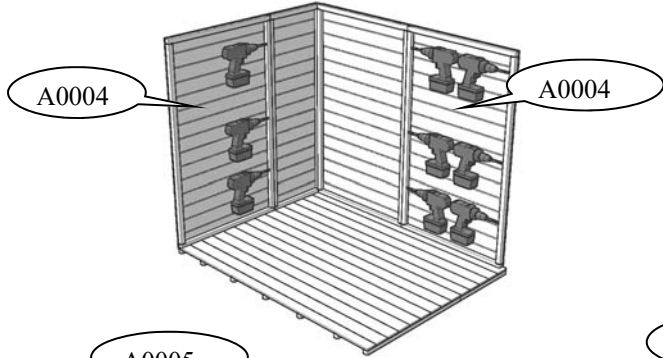

A0004

A0004

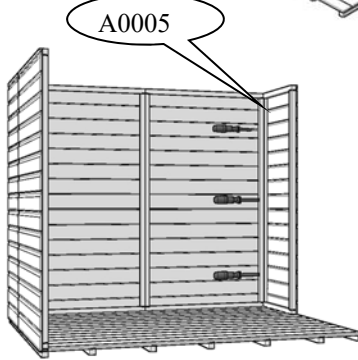

A0005

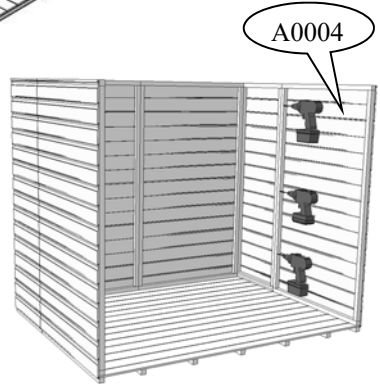

A0004

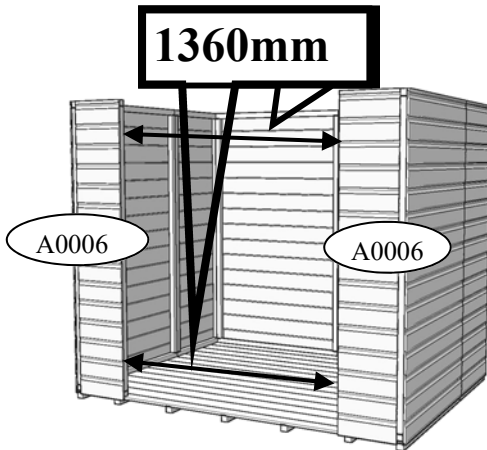

1360mm

A0006

A0006

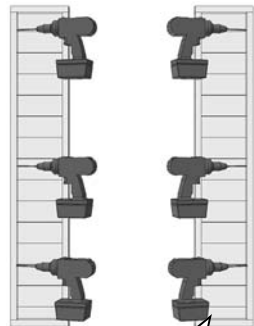

A0006-Drilling
from inside

GB-IE Align the gable "A0007" framework with the framework of the panels below
Drill 4 holes in each gable and fix with 60mm screws

04

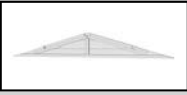
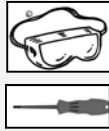
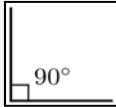

Gable panels
(GA0007) x02

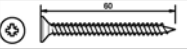

60mmScrews
(A0035)x08

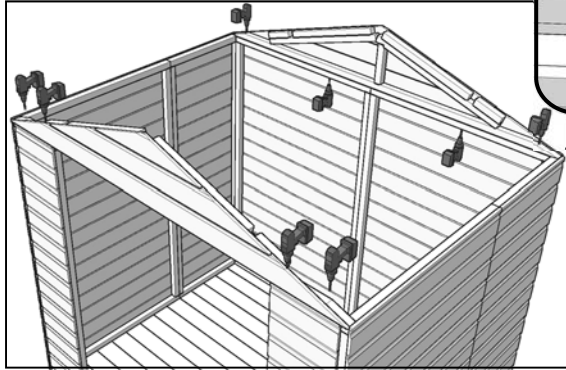

GB-IE Drill and fix the roof bearers at each end with 60mm screws and also fix the highest roof bearers together with 60mm screws.

05

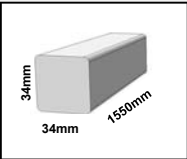
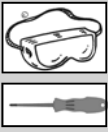
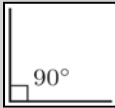

Roof bearers
(A0008)x04

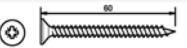

60mmScrews
(A0035)x11

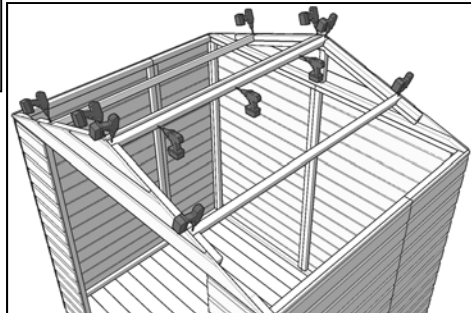
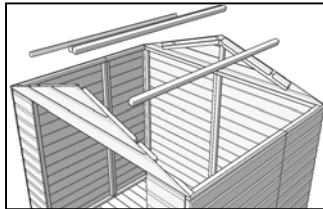

GB-IE

Position a roof edging under the long edge of each of the roof panels "A0009" and nail together.

06



NOTE
If you are fitting the optional veranda
The small veranda roof must be fitted
first
See veranda instructions

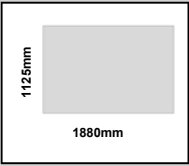

Roof panel
(A0009) x02

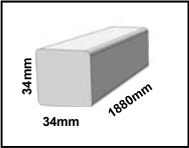

Roof edging
(A0010) x02

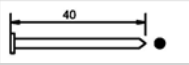

40mm Nails
(A0025)x14

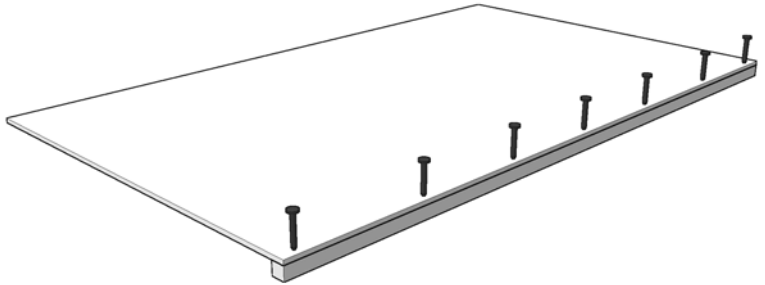

GB-IE

Fix the roof panels flush with the back and high point of the gables.
Nail at each gable into the walls and roof bearers then along the roof bearers at 300mm centres.

07

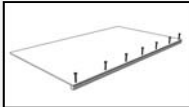
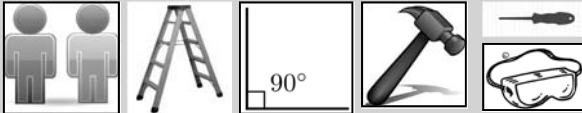

Step 6
06 x 02

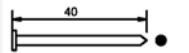

40mm Nails
(A0025)x36

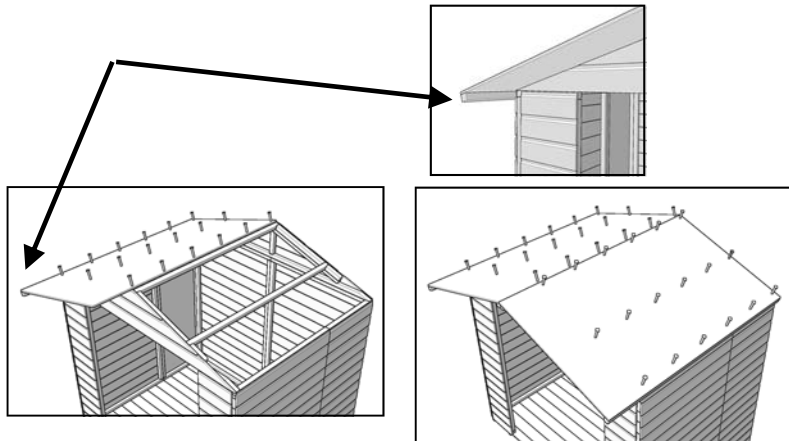

08

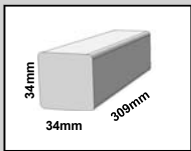
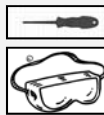
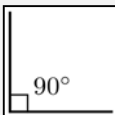

Roof overhang (A0011) x02

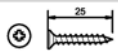

25mmScrews (A0032)x04

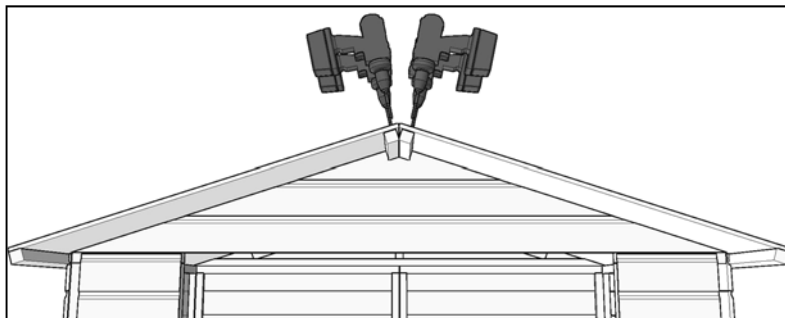

09

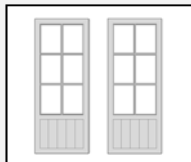
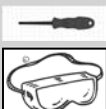

DOORS (A0012L&R)x02

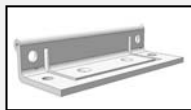

Hinges (A0013) x06

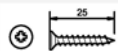

25mmScrews (A0032)x12

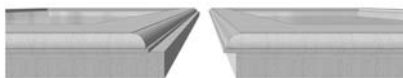

A0012L
Secondary door
Bolted

A0012R
Primary door
Opening first

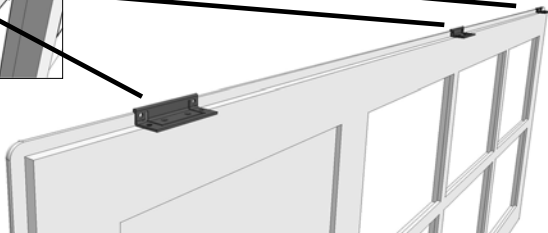
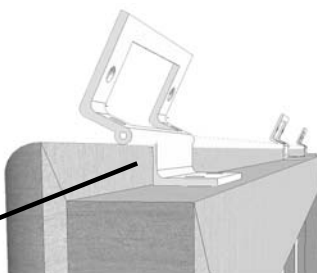
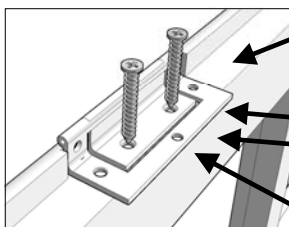

GB-IE

Fix both doors leaving an even gap top and bottom with 1 x 25mm screw at first
Adjust the door if necessary and fit the remaining screws

10

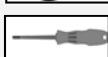
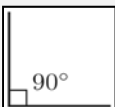

Doors
(A0012L&R)x 02

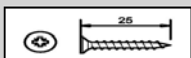

25mmScrews
(A0032)x30



Secondary door
Bolted



Primary door
Opening first

View on bottom of doors

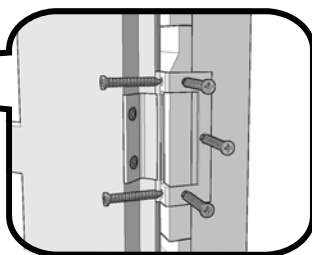
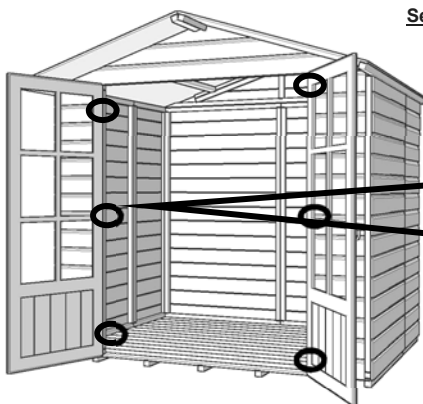

GB-IE

Fit a bolt to the top and bottom of the door and drill an 8mm hole for the shaft into the floor and gable framework.

11

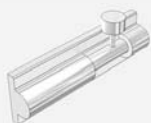
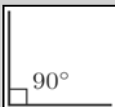

Door bolt
(A0014)x 02



10mmScrews
(A0028)x08

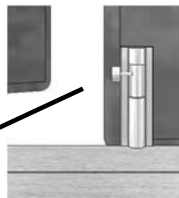
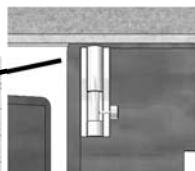
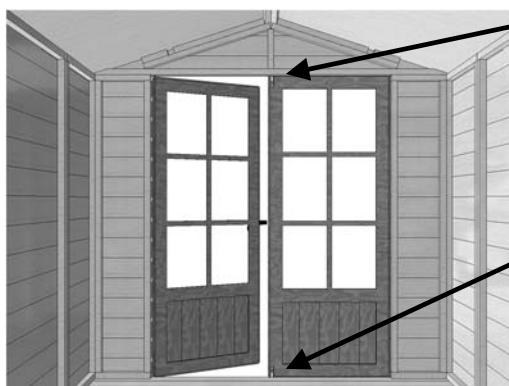

GB-IE

Position the Gate latch "A0015" on the outside over the **primary door** framework.
Mark the screw holes as shown. Drill the middle hole only and fit the "SQUARE SHAFT" in the hole,
locate the two ring handles onto the shaft and fix to the door
Align and fit the catch plate to the secondary door.

12

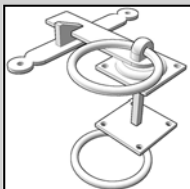
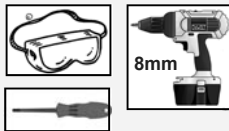

Gate latch
(A0015) x01



25mm Black screw
(A0031)x10

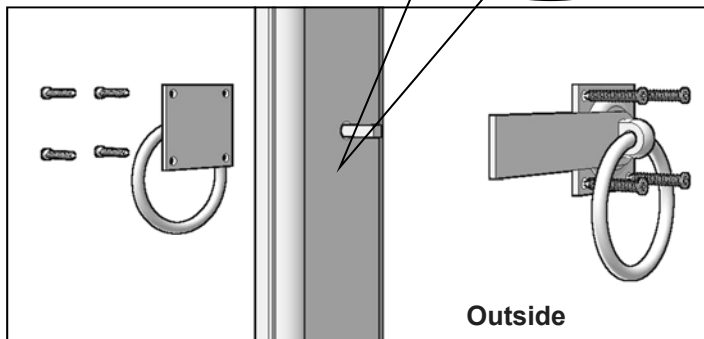
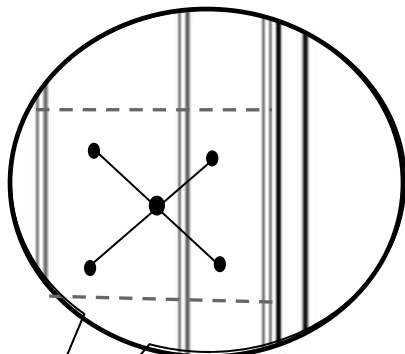
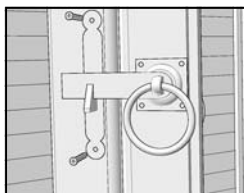

GB-IE

Fix the walls to the floor with 1x60mm screw per panel

13

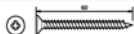
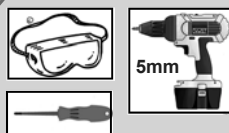

60mm Screws
(A0035) x8

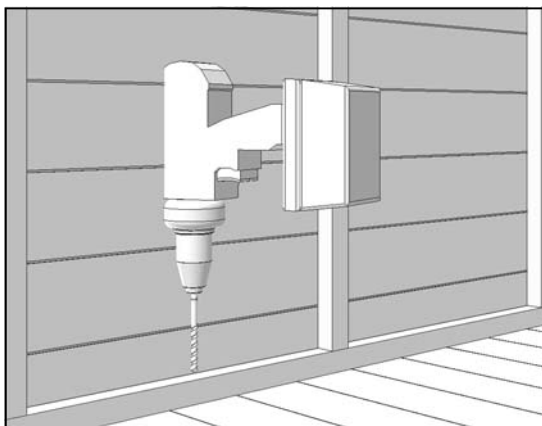

18

GB-IE

Fit cover strips at each corner and across the joins with 4 nails each

14

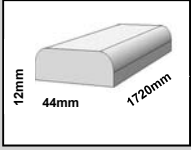

Cover strips (A0016) x07



40mmNails (A0025) x28

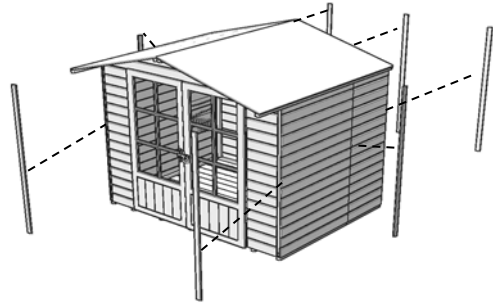

GB-IE

3 Strips of felt have been supplied .

Fit the 2 lower strips first folding the felt over the roof edging, with an even overhang front and back then secure with a couple of nails at the top to hold the felt in position and at the bottom nail at approximately 100mm centres

The third piece overlaps the lower pair and goes over the ridge. Nail at approximately 100mm centres

15

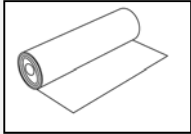

2.1mFelt strips (A0017)x03

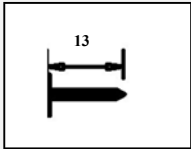

13mmFelt nails (A0023) x162

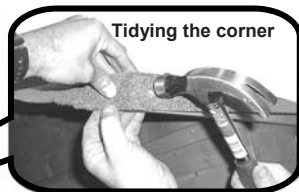
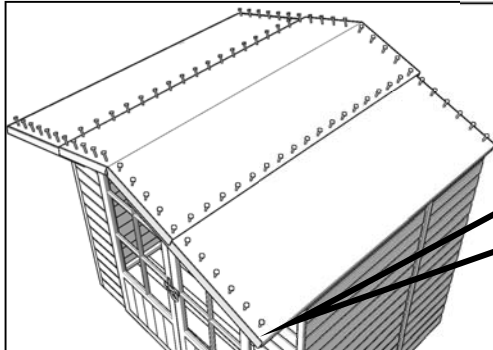
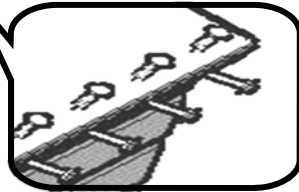
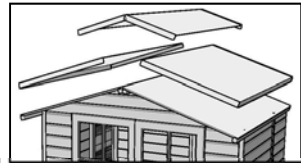
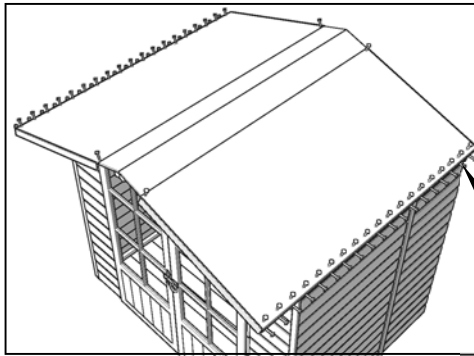

16



Fascia
(A0018)x04



Diamond
(A0019)x02

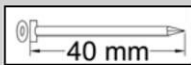

40mmNails
(A0025) x16

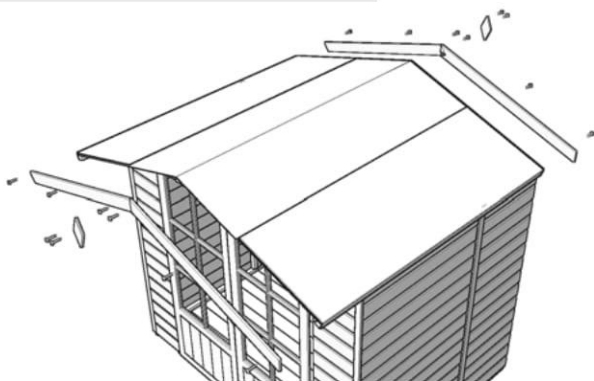

GB-IE



**GLASS HANDLE WITH CARE DANGER OF CUTTING
USE GLOVES ,SUITABLE SHOES AND CLOTHING**



Swap the beading around to get the best fit. Fit with 2 panel pins each
Get a helper to hold the glazing in position while you fit the beading

17

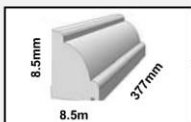

Beading
(A0021) x24

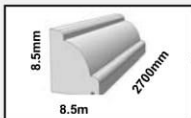

Beading
(A0022) x24

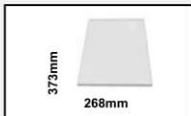

Glazing
(A0020) x12

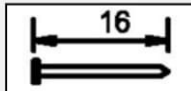

16mmPanel pins
(A0024) x96

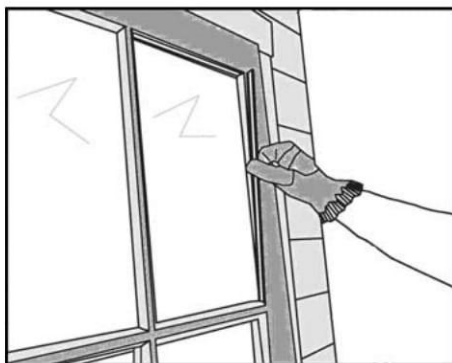

Building Photographs

It will be greatly appreciated if you could forward images of your completed building