

Assembly Instructions

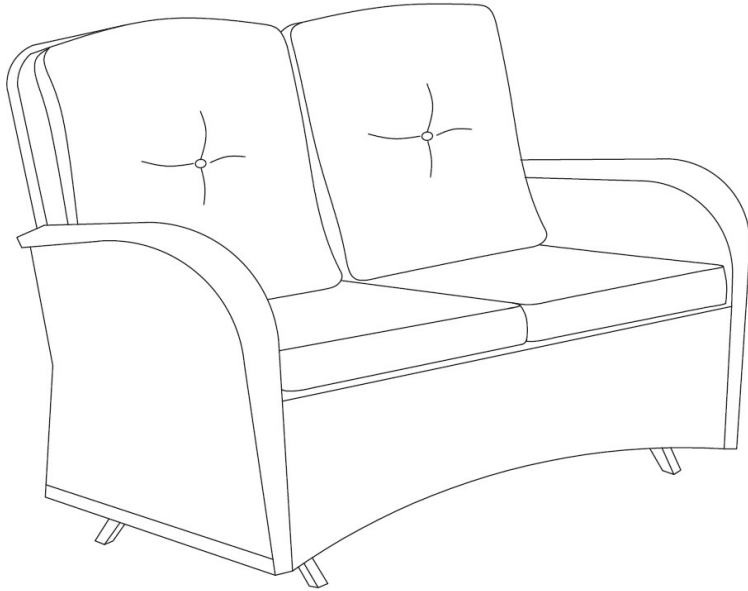

**Assembly
Video**







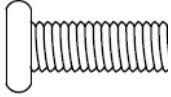
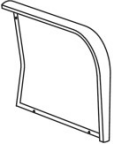

For any missing hardware, damaged parts and other problems.
WELCOME to email us at: service@behousewell.com

Or call at 1-888-733-8169 Toll free
Between 9AM and 5PM Eastern time, Monday through Friday

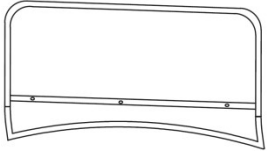
***Don't fully tighten all the bolts till the very end!**

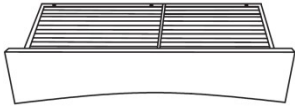
PRE-ASSEMBLY PREPARATION:

- Please read through the instructions before beginning assembly.
- Clear out the space for assembly and lay out all of the parts based on the Parts List, extra room will allow you to easily determine if all the pieces are present.
- Keep small parts and pieces away from children until fully assembled.

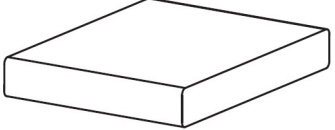
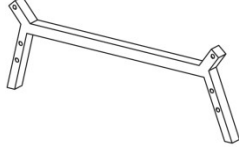
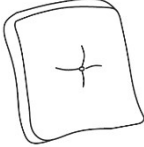
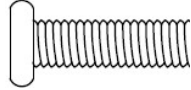
Part no.	Part	QTY	Image	Part no.	Part	QTY	Image
A1	Left arm	1		H	Bolt (M6*40mm)	17	
A2	Right arm	1		I	Nut M6	16	
B	Back	1		J	Washer M6	33	
C	Seat	1		K	Allen wrench	1	
D	Connecting rod	2		L	Wrench	1	
E	Swing arm	4		M	Seat cushion	2	
F	Foot stand	2		N	Back cushion	2	
G	Bolt (M6*45mm)	8					

Step 1: Attach seat C to arms A1&A2 with 2pcs bolts H and 2pcs washers J, using Allen wrench K. Note: Don't fully tighten the bolts.

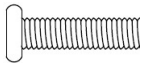

Bolt H x 2
M6*40mm



Washer J x 2

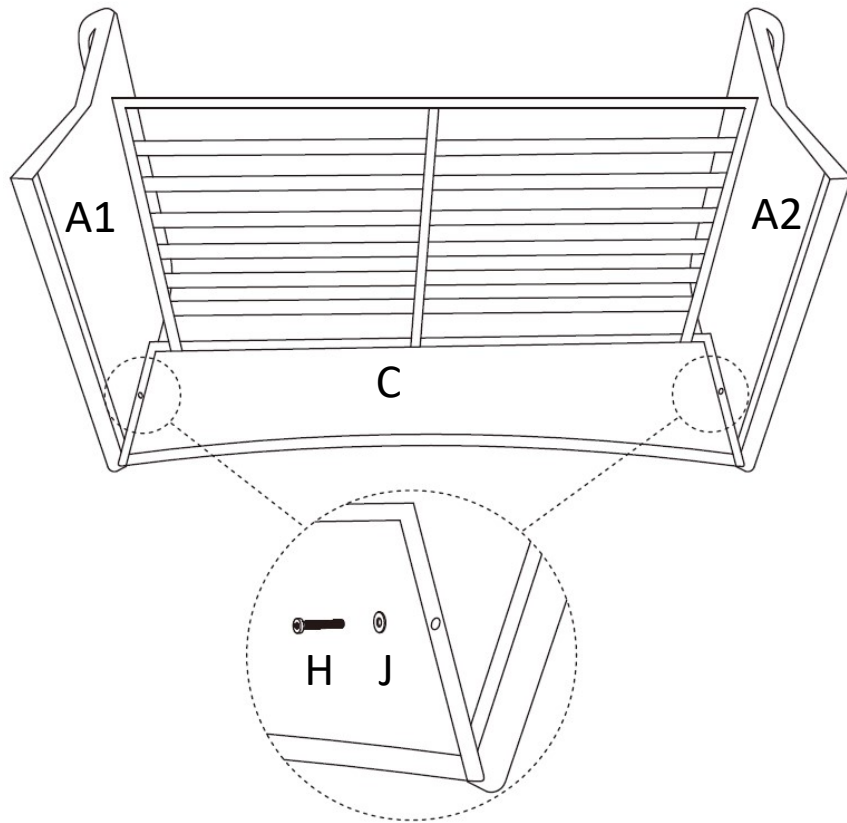

Step 2: Attach back B to arms A1&A2 with 4pcs bolts H and 4pcs washers J, using Allen wrench K. Note: Don't fully tighten the bolts.

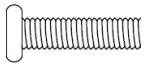

Bolt H x 4
M6*40mm



Washer J x 4

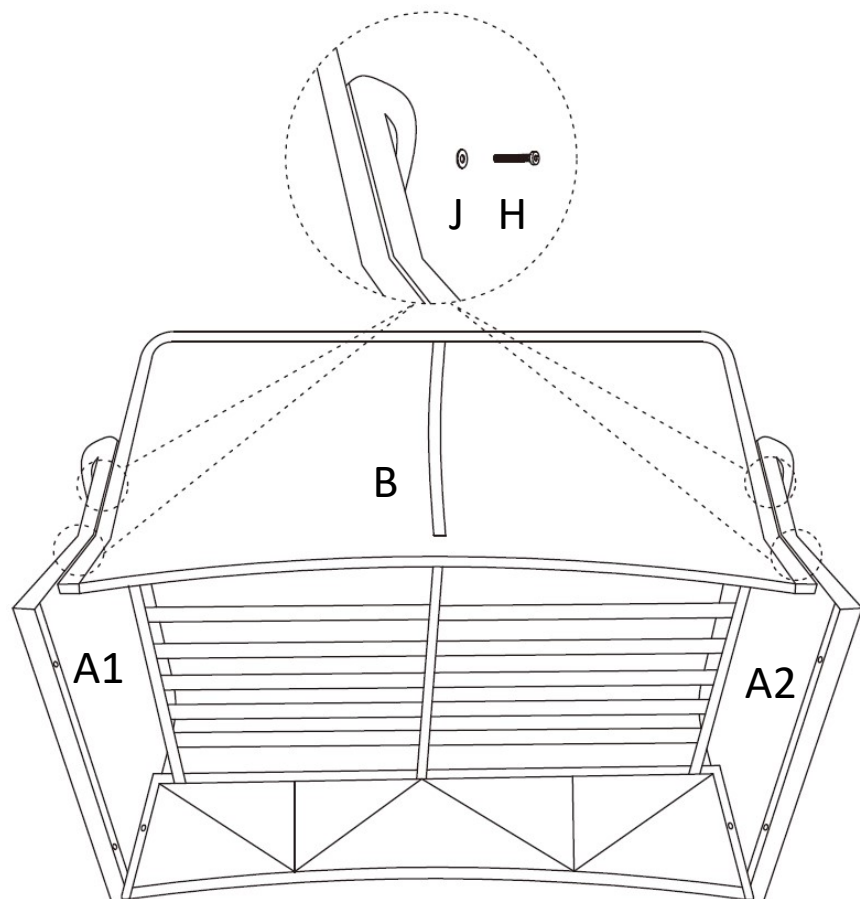

Step 3: Attach seat C to back B with 3pcs bolts H and 3pcs washers J, using Allen wrench K. Note: Please fully tighten all the bolts.



Bolt H x 3
M6*40mm



Washer J x 3

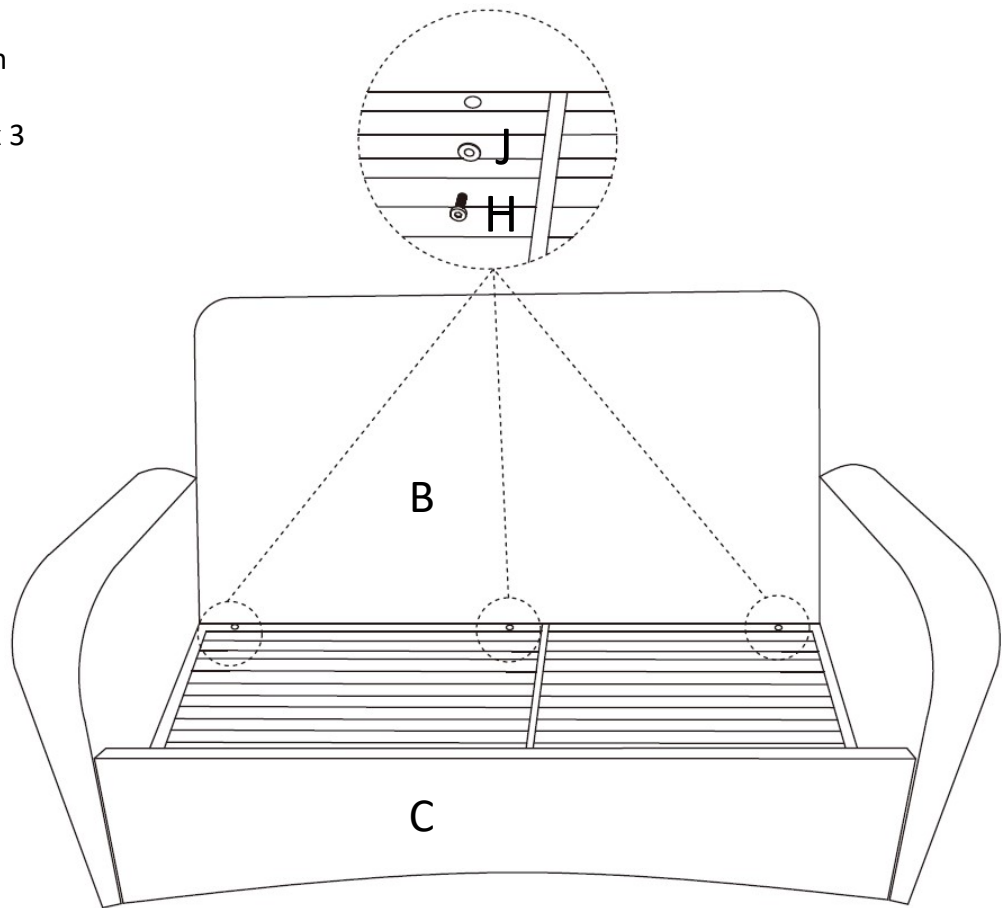

Step 4: Attach 4pcs swing arms E to 2pcs foot stands F with 4pcs bolts G, 4pcs washers J and 4pcs nuts I, using Allen wrench K and wrench L. Note: Don't fully tighten the bolts.



Bolt G x 4
M6*45mm



Washer J x 4



Nut I x 4

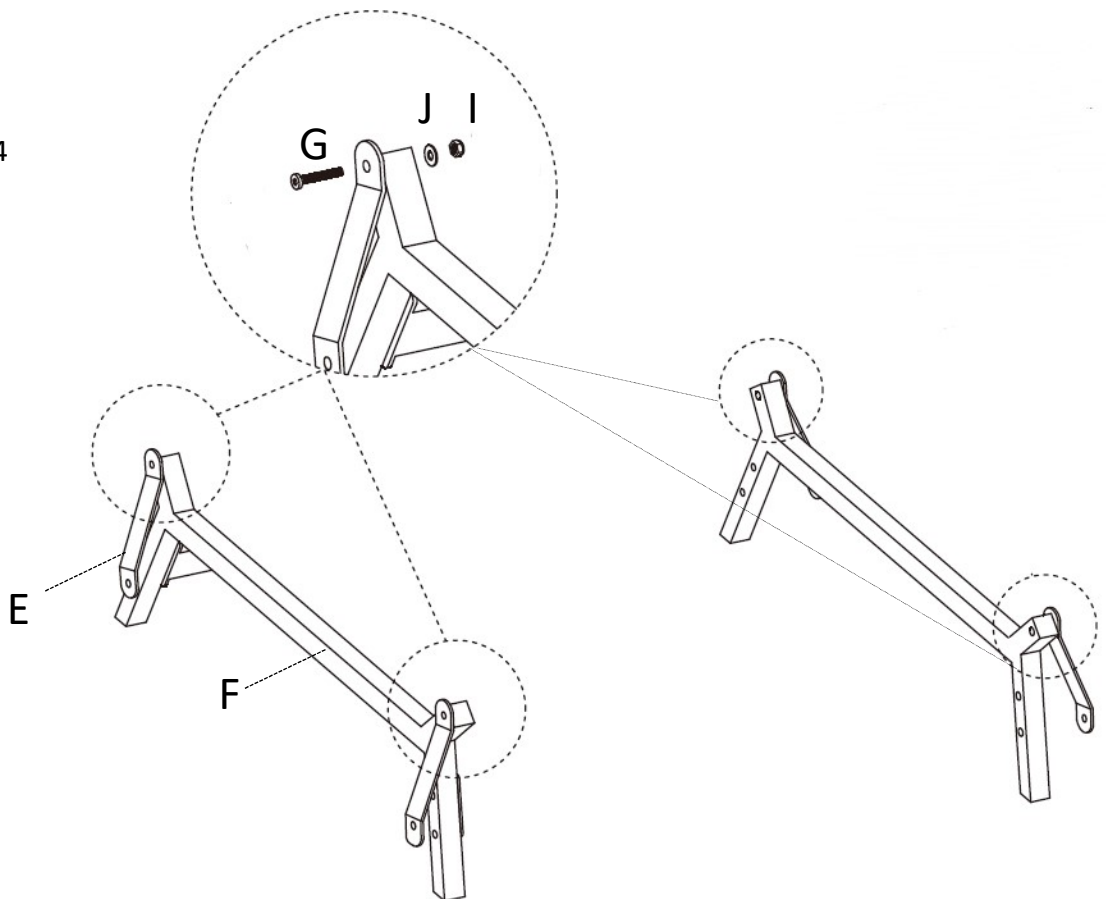

Step 5: Attach connecting rods D to foot stands F with 8pcs bolts H and 16pcs washers J and 8pcs nuts I, using Allen wrench K and wrench L. Note: Place horizontally and fully tighten all the bolts.

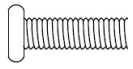

Bolt H x 8
M6*40mm



Washer J x 16



Nut I x 8

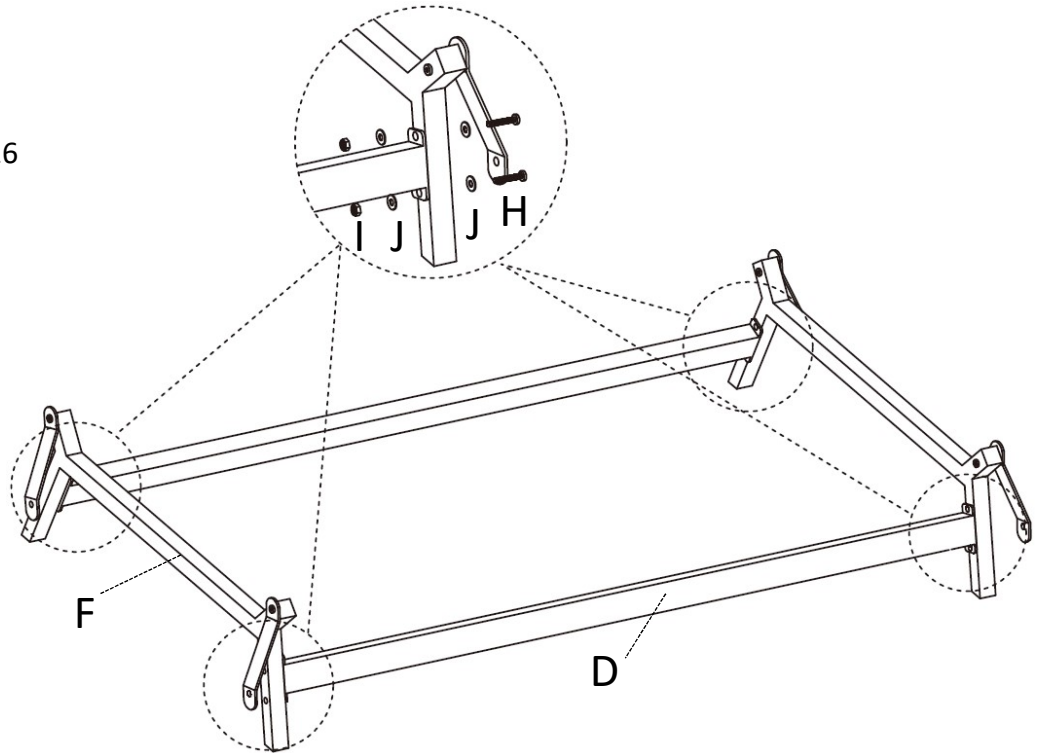

Step 6: Attach 4pcs swing arms E to arms A1&A2 with 4pcs bolts G, 4pcs washers J and 4pcs nuts I, using Allen wrench K and wrench L. Note: Don't fully tighten the bolts until they are locked.

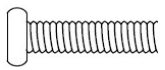

Bolt G x 4
M6*45mm



Washer J x 4



Nut I x 4

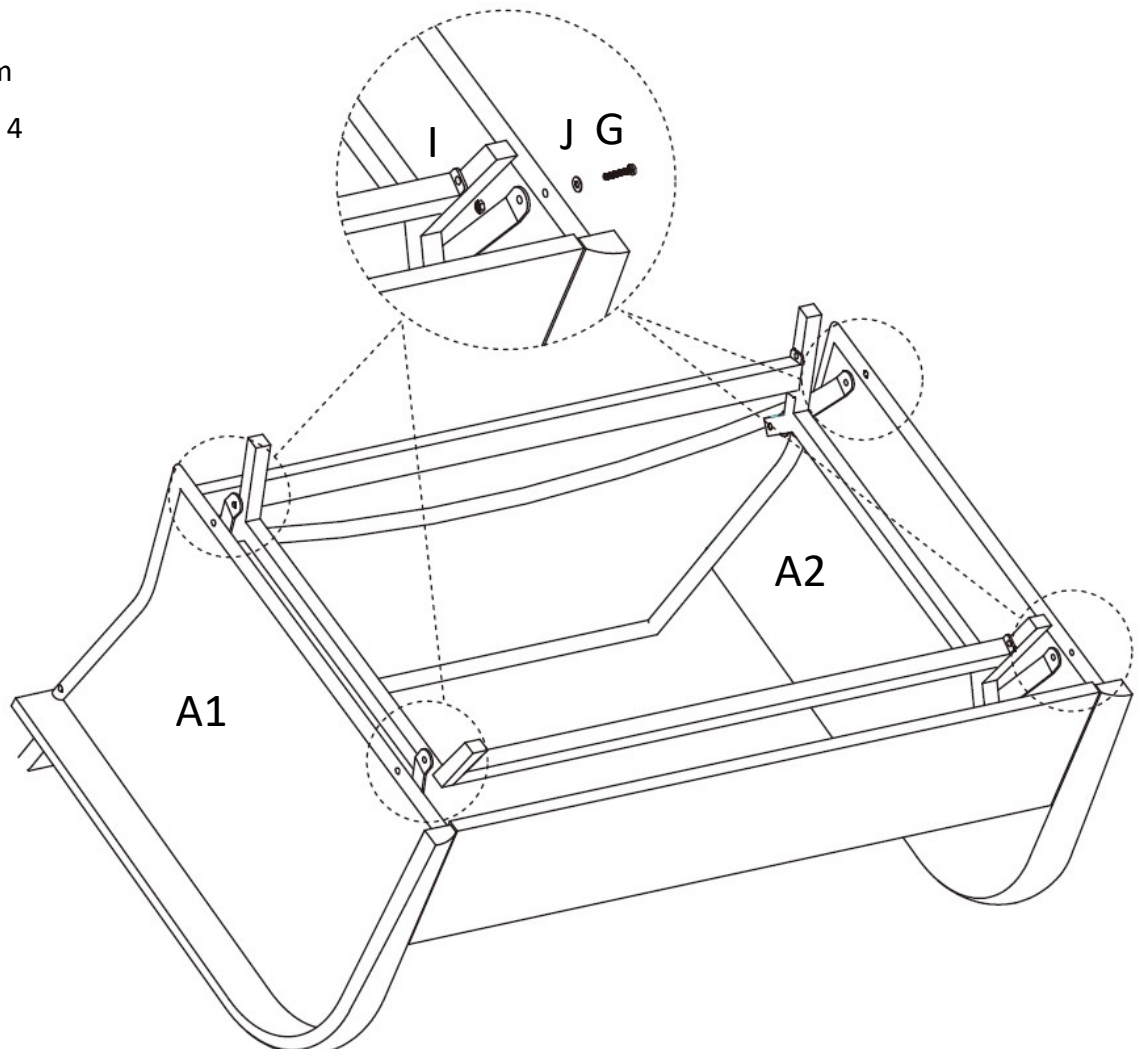

Step 7: Put back cushions N and seat cushions M onto the seat .
Assembly is now complete and the product is ready for use.

