

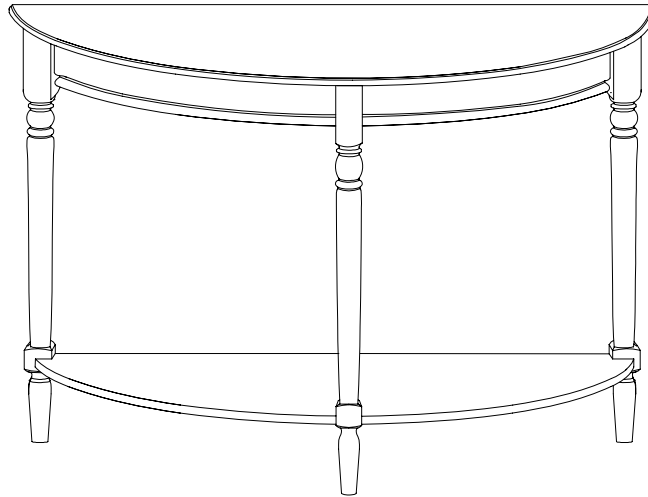





ENTRYWAY TABLE

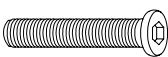

HARDWARE LIST

CODE	NAME	FIGURE	Q'TY
A	CAM LOCKS		3PCS
B	CAM BOLTS		3PCS
C	RAIL SCREW (Φ1/4"*38mm)		6PCS
D	SPRING WASHER (Φ1/4")		6PCS
E	FLAT WASHER (Φ1/4"*16mm)		6PCS
F	ALLEN WRENCH		1PC

PARTS LIST

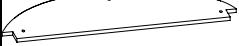
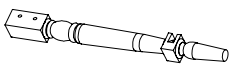
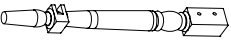
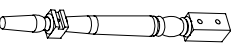
CODE	NAME	FIGURE	Q'TY
①	TOP PANEL		1PC
②	BOTTOM PANEL		1PC
③	LEFT LEG		1PC
④	RIGHT LEG		1PC
⑤	CENTER LEG		1PC



Please do not return to the store

STEP 1

B x 3pcs

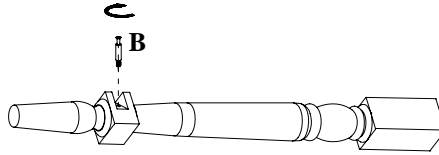

- 1.) Screw Cambolts (B) into Legs (3-5).

STEP 2

A x 3pcs

- 1.) Place Cam Locks (A) into Bottom Panel (2).

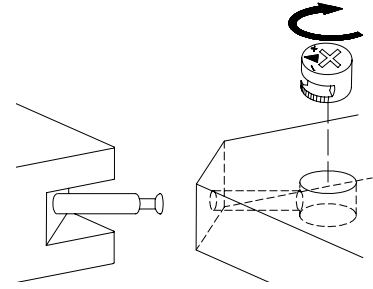

**Arrow On Cam Lock Faces
Outward Opening ****

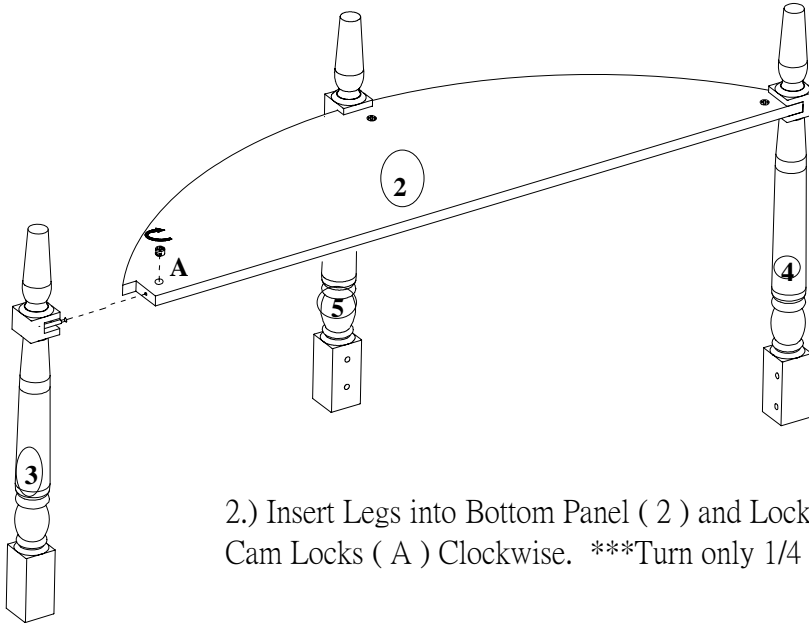

- 2.) Insert Legs into Bottom Panel (2) and Lock into position by turning Cam Locks (A) Clockwise. ***Turn only 1/4 of the way for lock position.***

STEP 3

- 1.) Place Leg Assembly onto Top Panel (1).

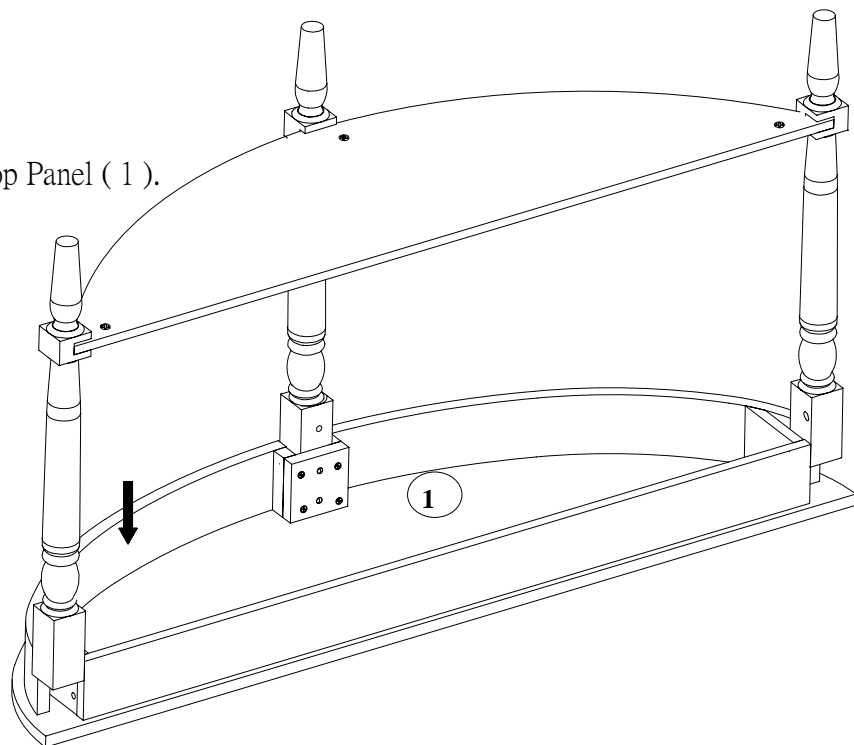

STEP 4

C × 6pcs
D × 6pcs
E × 6pcs
F × 1pc

1.) Assemble Rails Screws (C) with Spring Washer (D) and Flat Washer (E) in order as shown.

2.) Using Allen Wrench (F), fasten Rail Screw Assembly to secure Top Panel (1) to Leg Assembly.

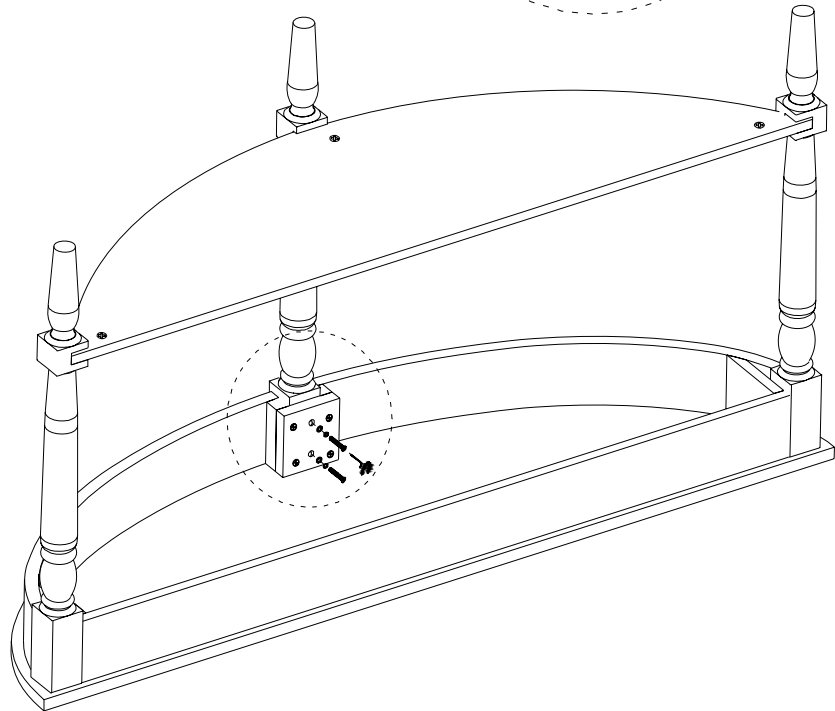
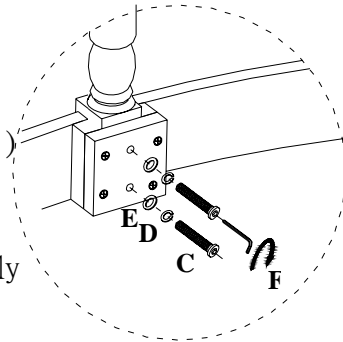

STEP 5

Enjoy your new quality piece of furniture for years to come!

