









# ASSEMBLY INSTRUCTIONS

## DINING TABLE

Thank you for purchasing this quality product. Be sure to check all packing materials carefully for small parts, which may have come loose inside the carton during shipment. Identify and count all parts and compare with the part list below.

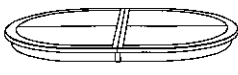
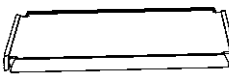
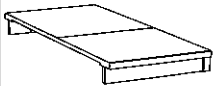
HARDWARE LIST			
NO.	DRAWING	DESCRIPTION	QTY
A		Flat Washer 5/16"	20 pcs
B		Spring Washer 5/16"	20 pcs
C		Allen Bolt 5/16" x 3"	8 pcs
D		Allen Bolt 5/16" x 1 1/2"	4 pcs
E		Allen Bolt 1/4" x 1 3/4"	8 pcs
F		Leveler	4 pcs
G		Wood Dowel Ø10 x 30 mm	4 pcs
H		Allen Key	1 pc

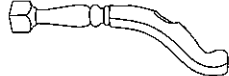
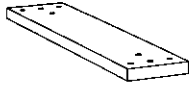
PART LIST		
1  Table Top (1 pc)	3  Lower Panel (1 pc)	5  Table Leaf (1 pc)
2  Wine shelf (1 pc)	4  Table Leg (4 pcs)	6  Middle Panel (2 pcs)

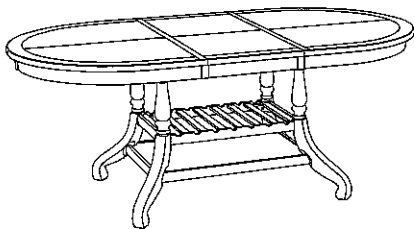

### STEP 1

Attach the Wine Shelf (2) to the Table Leg (4) by using Flat Washer (A), Spring Washer (B), Allen Bolt (C), and tighten using Allen Key (H).

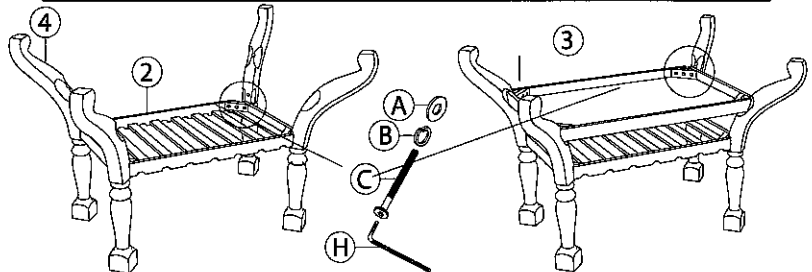

### STEP 2

Attach the Lower Panel (3) to the Table Leg (4) by using Flat Washer (A), Spring Washer (B), Allen Bolt (C), and tighten using Allen Key (H).

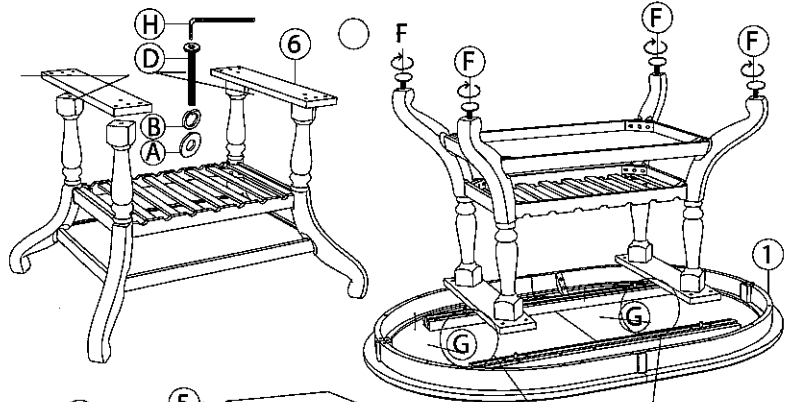

### STEP 3

Attach the Middle Panel (6) to the Table Leg (4) by using Flat Washer (A), Spring Washer (B), Allen Bolt (D), and tighten using Allen Key (H).

### STEP 4

Insert Wood Dowel (G) on the Table Top (1) rails. Attach the Middle Panel (6) to the Table Top (1) by using Flat Washer (A), Spring Washer (B), Allen Bolt (E), and tighten using Allen Key (H). Attach Leveler (F) into the pre-drilled holes on the bottom of the Table Leg (4).

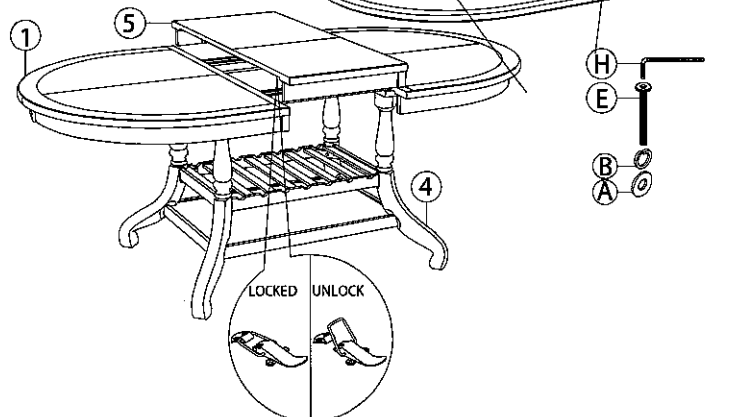

### STEP 5

Turn the table upright. Unlock the latches located underneath the Table Top (1). Pull apart the Table Top (1) at both ends and place the Table Leaf (5) in the center. Push both ends together to close and lock the latches.

Assembly is now completed.

### CLEANING INSTRUCTION







Clean the surface with a furniture polish and a soft cloth



MADE IN VIETNAM

# ASSEMBLY INSTRUCTIONS

## DINING CHAIR

Thank you for purchasing this quality product. Be sure to check all packing materials carefully for small parts, which may have come loose inside the carton during shipment. Identify and count all parts and compare with the part list below.

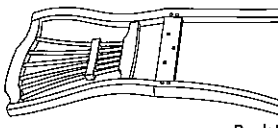
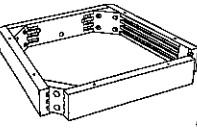
HARDWARE LIST			
NO.	DRAWING	DESCRIPTION	QTY
A		Flat Washer 5/16"	22 pcs
B		Spring Washer 5/16"	22 pcs
C		Nut 5/16"	8 pcs
D		Allen Wrench	1 pc
E		Short Bolt 1/4" x 1 3/4"	6 pcs
F		Long Bolt 1/4" x 3"	8 pcs
G		Wood Screw 5/32" x 1 1/2"	12 pcs

PART LIST	
1	 Back Leg (2 pcs)
2	 Seat Frame (2 pcs)
3	 Cushion Seat (2 pcs)
4	 Front Leg (4 pcs)

### STEP 1

Attach the Front Leg (4) to the Seat Frame (2) by using Nut (C), Spring Washer (B), and Flat Washer (A).

Note: The Seat Frame (2) has two screw holes on each side, which are used for attaching the seat. These holes are wider on the bottom and narrower on the top. Ensure the wider holes face towards you.

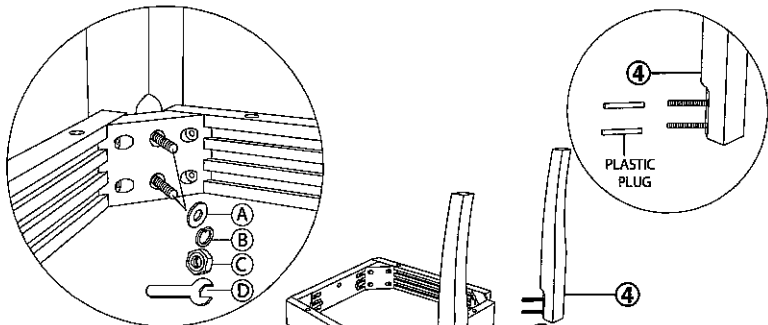

### STEP 2

Attach the Seat Frame (2) to the Back Leg (1) by using Short Bolt (E), Long Bolt (F), Spring Washer (B) and Flat Washer (A). Do not fully tighten.

Turn the chair upright. Make sure the assembled unit is level and square. Tightly fasten all Nuts (C) and Bolts (E&F) with the Allen Wrench (D).

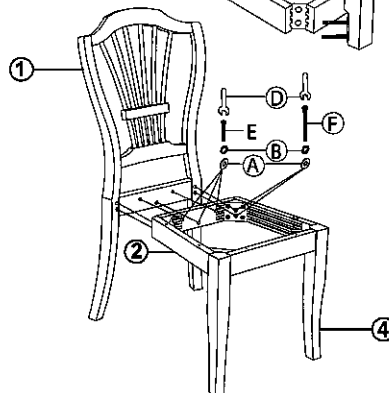

### STEP 3

Place the Cushion Seat (3) upside down on a non-abrasive table surface. The rear (tapered end) should be near the table edge.

Hint: Protect the non-abrasive table surface and the Cushion Seat (3) by laying a towel in-between the chair seat and table.

Place the assembled chair frame on the Cushion Seat (3). Attach with Wood Screw (G). Tighten the screws.

The Dining Chair is now ready for use.

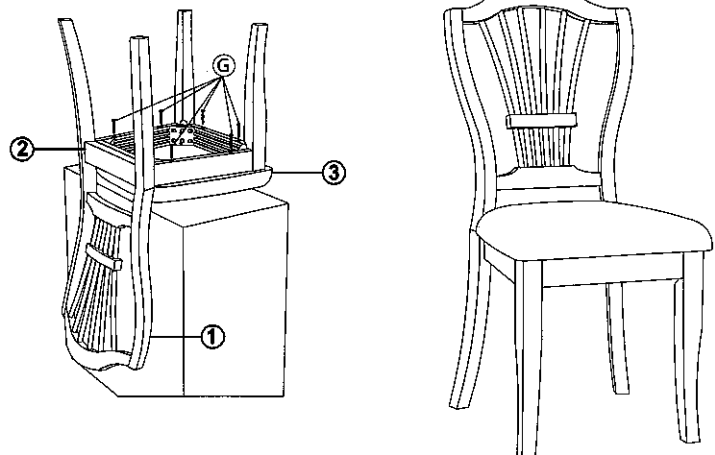

### CLEANING INSTRUCTION

Clean the surface with a furniture polish and a soft cloth

**MADE IN VIETNAM**