

Assembly Instructions

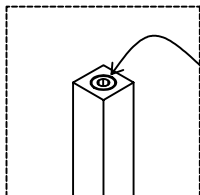
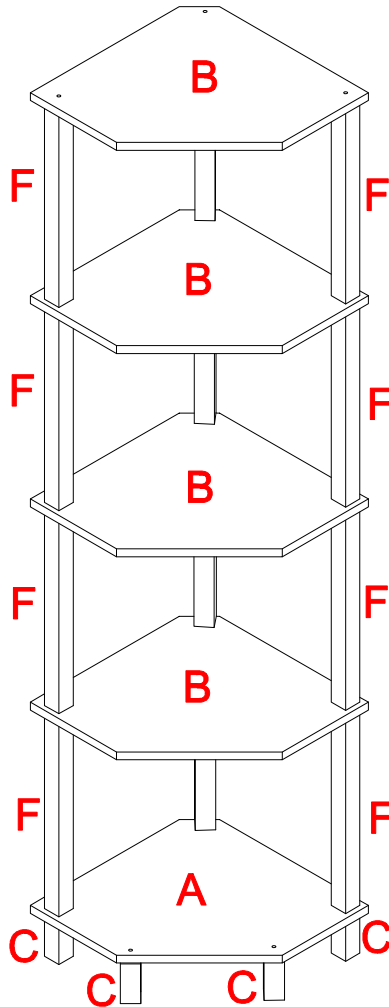

Note:when connecting the support legs,do not apply excessive force to prevent the screw holes from cracking.

BEFORE STARTING

Before Using Product

- Read each step carefully before starting. It is very important that each step is performed in the correct order. If these steps are not followed in sequence, assembly difficulties will occur.
- Make sure all parts are included.
- Work in a spacious area and near where the unit will be used, preferably on a carpet, or use a piece of the cardboard packaging to protect your floor and product.
- For a smooth assembly process, we suggest you keep a little tightness for all the screws during assembly. After the whole product is assembled, firmly tighten all the screws.

WARNING

- Do not allow children to climb on unit.
- Avoid sharp objects or corrosive chemicals to prevent damage to the product.
- During assembly, keep parts and packaging materials away from children and pets as there could be potential injury and choking hazards.
- Please make sure that all objects are removed before moving the assembled unit.
- The unit must be team lifted, not dragged or pushed. Failure to do so could cause instability, product collapse, and/or serious injury.
- Be careful when using power tools to assemble your furniture. Power tools may strip or damage the parts.

HARDWARE LIST

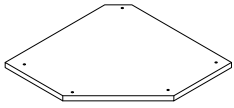

A x 1pc

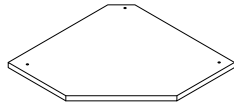

B x 4pcs



C x 5pcs



F x 12pcs

PARTA LIST



① x 5pcs

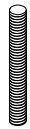

② x 12+1pcs

M6 x 40mm



M4*1



③ x 5+1pcs

M6 x 25mm

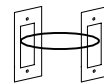

M4x40mm
M3x14mm



④ x 1pc

STEP1

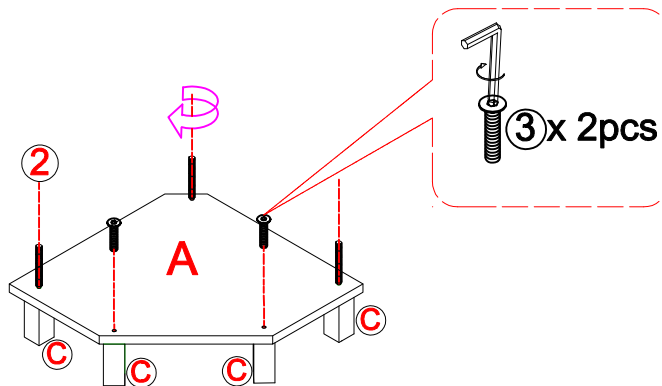

A x 1pc

C x 5pcs

② x 3pcs

③ x 2pcs

STEP2

F x 3pcs

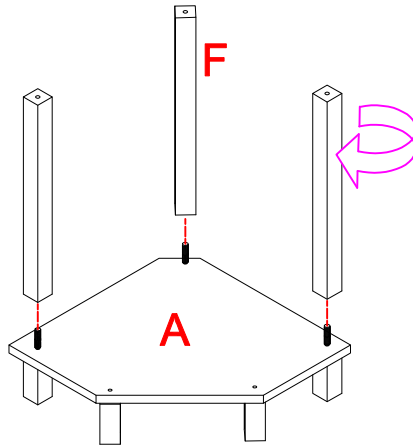

STEP3

B x 1pc

② x 3pcs

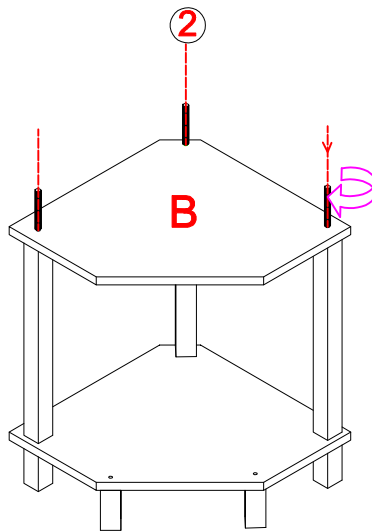

STEP4

F x 3pcs

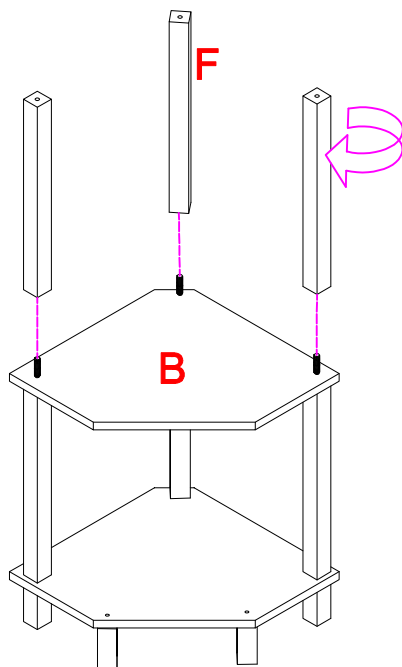

STEP5

B x 1pc

② x 3pcs

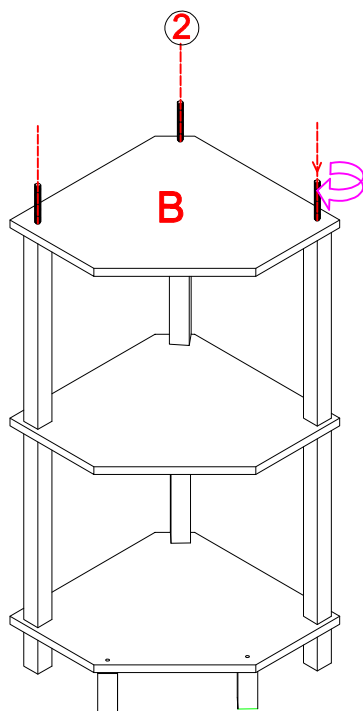

STEP6

F x 3pcs

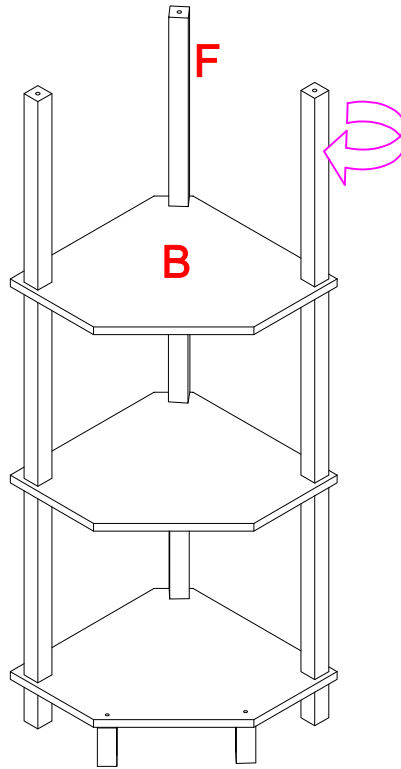

STEP7

B x 1pc

2 x 3pcs

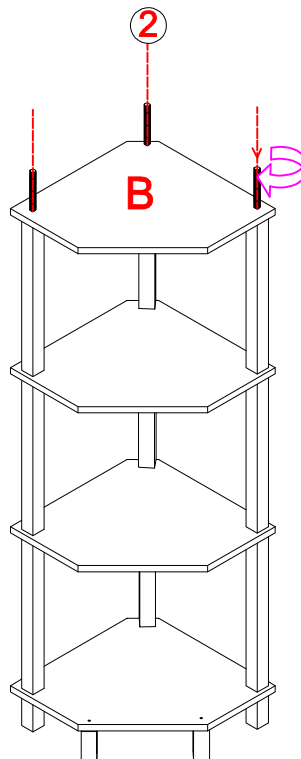

STEP8

F x 3pcs

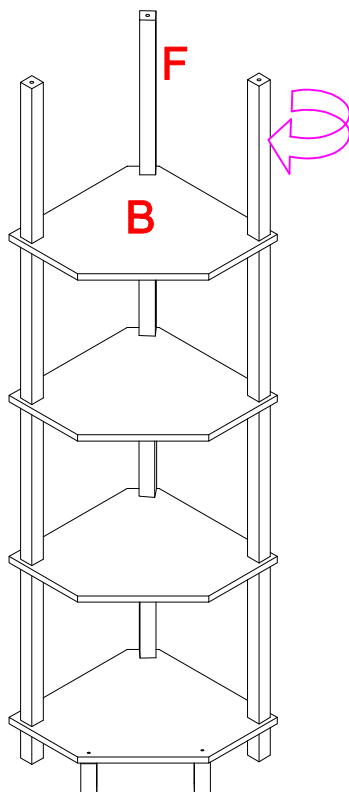

STEP9

B x 1pc

③ x 3pcs

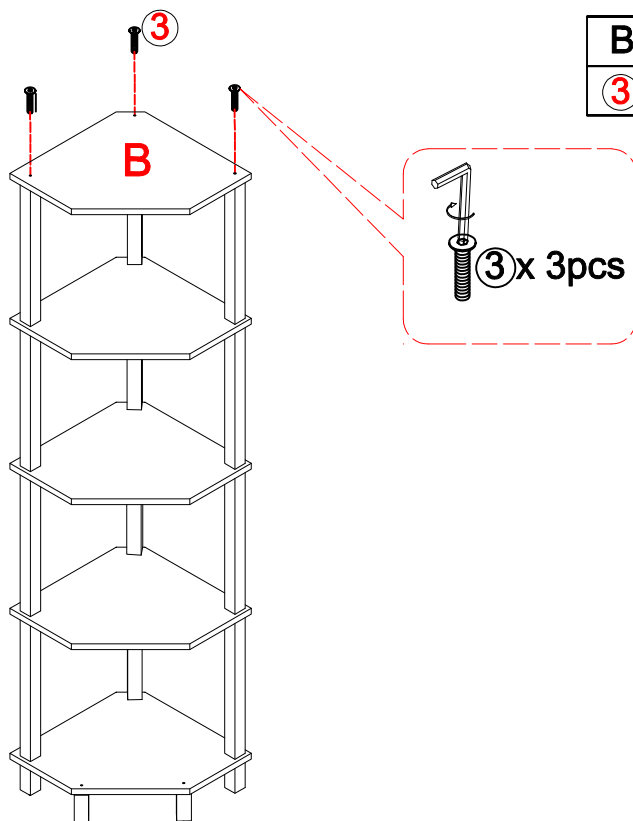

STEP10

① x 5 pcs

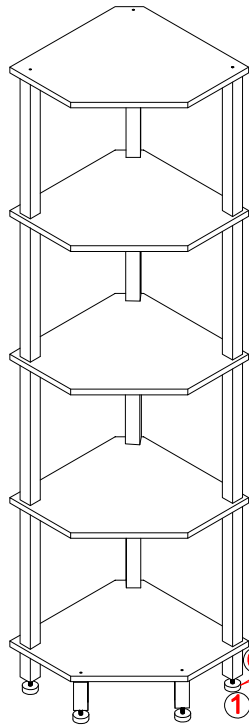

Adjust the height of the screw teeth on the feet appropriately to ensure the product remains perfectly level and more fit the ground. 

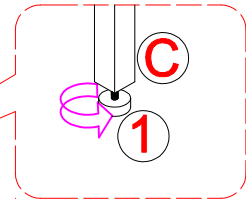

STEP11

④ x 1 pc

