

ASSEMBLY INSTRUCTIONS

CORNER HUTCH

ITEM# 23592

ASSEMBLY

2 HOURS

2 -Person Assembly

Tools Required (Not Provided):

REQUIREMENTS

Assembly Time

(Approximate)

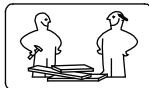

Phillips Screwdriver

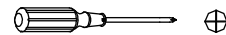

Flat Head Screwdriver

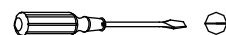

Thank you for purchasing our product!

Please refer and use this assembly instruction to assemble the product.
Contact our customer service department in case there are any missing or damage parts or hardware.
Replacement parts are normally shipped within 2 or 3 days.

Email: replacementparts@buylateral.com
Within 30 days from delivery date

We appreciate your business!

PRODUCTS PURCHASED THROUGH OUR AUTHORIZED VENDORS ONLY ARE ELIGIBLE FOR REPLACEMENT PARTS.

THIS PRODUCT IS FOR INDOOR AND HOUSEHOLD USE ONLY - NOT FOR COMMERCIAL USE.

ASSEMBLY PREPARATION

1. Remove all packaging materials, staples and packing straps from the carton.
2. Refer to Parts List and Hardware List and ensure they are correct before assembly.
Contact customer service for missing parts.
3. Place all wooden parts on a clean, flat and soft surface (e.g. carpet or rug) to prevent parts from getting scratched.

SAFETY PRECAUTION

1. KEEP ALL HARDWARE PARTS OUT OF REACH OF CHILDREN.
2. DISPOSE PLASTIC PACKAGING MATERIAL IMMEDIATELY TO AVOID ANY RISK OF SUFFOCATION TO CHILDREN AND ANIMALS.

TIPS FOR ASSEMBLY

1. Allow ample room for assembly and in close proximity to where product will be placed.
2. Assemble the product on a surface that does not scratch or damage the exterior gloss and finish of the furniture.
3. Identify all of the parts, hardware and quantities required for each step.
4. During assembly, do not over-tighten any fittings as this may cause damage.
5. DO NOT USE POWER TOOLS TO ASSEMBLE THIS PRODUCT.
6. Always place the product on a flat, level surface.
7. Do not sit or stand on the partially assembled product; only use the product for which it is intended.

CARE AND MAINTENANCE





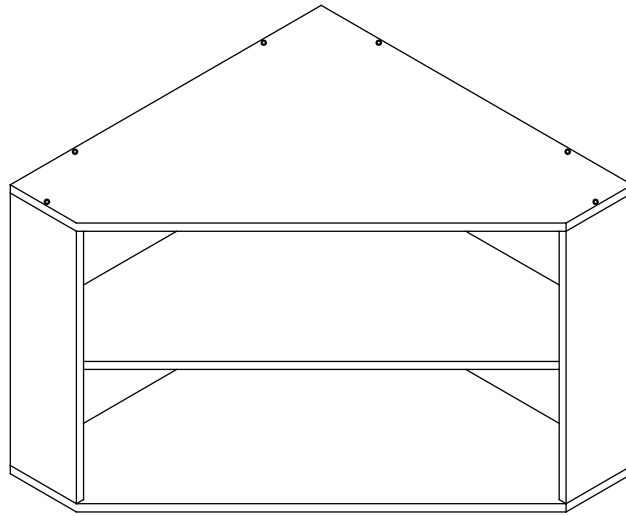

1. Wipe clean with a soft, dry cloth; avoid the use of harsh chemicals or household cleaners as they may damage the exterior finish of the furniture.
2. Hardware may loosen over time. Periodically, check that all connections are tight; re-tighten as necessary.
3. Solid wood is impacted by heat and humidity fluctuations which may cause small joint separations or hairline cracks; place the furniture away from direct sunlight and air conditioning vents, heating vents or units to protect the furniture.

ASSEMBLY INSTRUCTIONS



CORNER HUTCH ITEM# 23592



Hardware List

| ITEM | DESCRIPTION | PART | QTY | ITEM | DESCRIPTION | PART | QTY |
|------|-------------|---|--------|------|----------------|--|-------|
| A | Cam-bolt |  6*35mm | 4 pcs | E | Screw |  3.5*40mm | 4 pcs |
| B | Cam-lock |  15*10mm | 4 pcs | F | Plastic Anchor |  | 4 pcs |
| C | Wood Dowel |  5.8*30mm | 28 pcs | G | Glue |  | 1 pc |
| D | Screw |  4*30mm | 18 pcs | | | | |

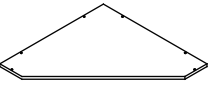
Parts List

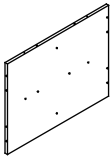
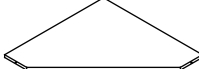
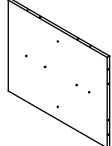
| ITEM | DESCRIPTION | PART | QTY | ITEM | DESCRIPTION | PART | QTY |
|------|--------------------|---|-------|------|-------------|---|-------|
| 1 | Large Panel |  | 2 pcs | 4 | Front Panel |  | 2 pcs |
| 2 | Larger Side Panel |  | 1 pc | 5 | Shelf Panel |  | 1 pc |
| 3 | Smaller Side Panel |  | 1 pc | | | | |

ASSEMBLY INSTRUCTIONS

CORNER HUTCH ITEM# 23592

Parts List

Assembly Overview

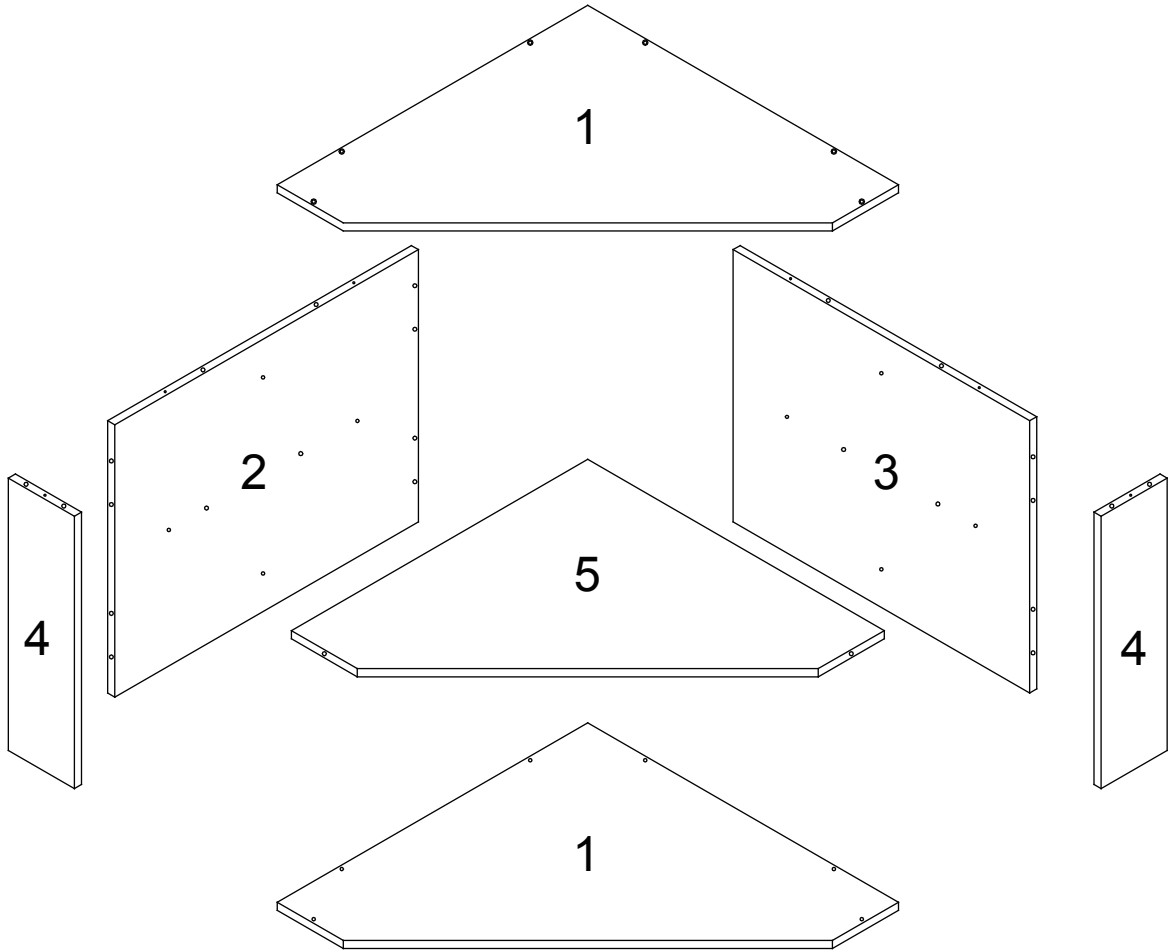

Instructions For Fastening CAM-BOLT AND CAM-LOCK



CAM-BOLT



CAM-LOCK

Tools Required

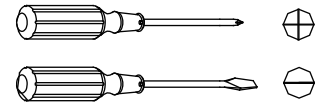

INSERTING AND TIGHTENING CAM-BOLT

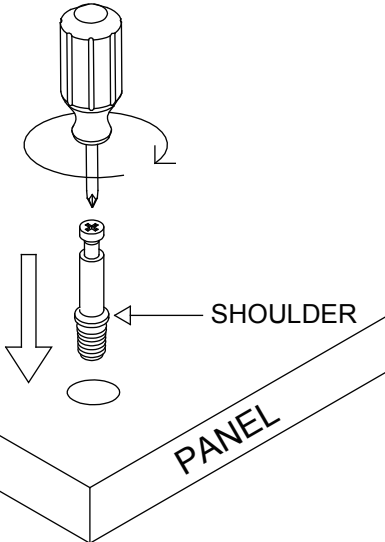

Place Cam-bolt on pre-drilled hole and screw in vertically.

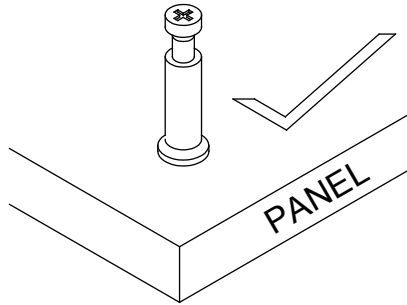

Shoulder is flushed (on the same level) with the panel.

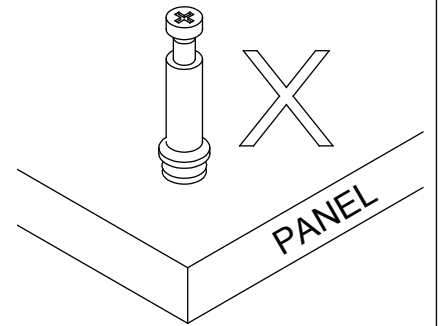

Shoulder is above the panel.

Place Cam-bolt to the designated pre-drilled holes on the panel. Use a Phillips Screwdriver to tighten Cam-bolt vertically until shoulder is flushed (on the same level) with panel. Do not over-tighten or under-tighten.

INSERTING CAM-LOCK

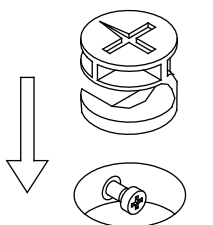

Cam-bolt head needs to be in centre

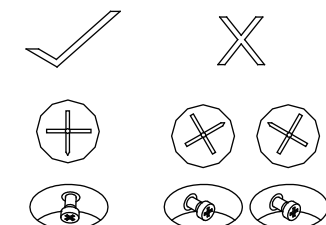

CORRECT

WRONG

Align the arrow on the Cam-lock to the Cam-bolt head and insert the Cam-lock. Ensure Cam-lock is fully inserted.

TIGHTENING CAM-LOCK

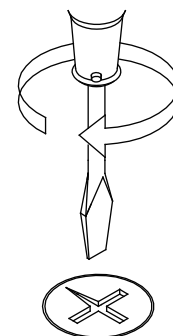

Use a Flat-head Screwdriver to turn Cam-lock clockwise so it locks onto the head of the Cam-bolt. Turn until it is snug (about one half of a turn) -- over-tightening could damage Cam-lock or/and Cam-bolt.

STEP 1

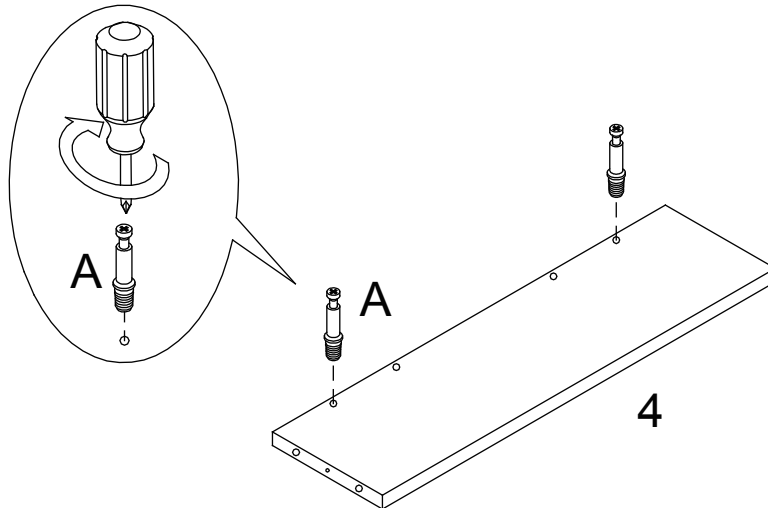
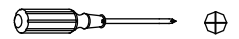

| | | |
|---|--|-------|
| A |  | 4 pcs |
|---|--|-------|



X 2

- Place Front Panel (4) with interior side face up, as shown, on a material that does not scratch its exterior surface.
- Screw in Cam-bolt (A) into designated holes on (4). Refer to Page 4 for instructions on fastening Cam-bolt.

STEP 2

| | | |
|---|---|-------|
| D |  | 2 pcs |
| C |  | 2 pcs |

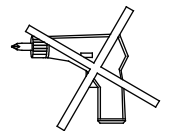

DO NOT USE POWER TOOLS

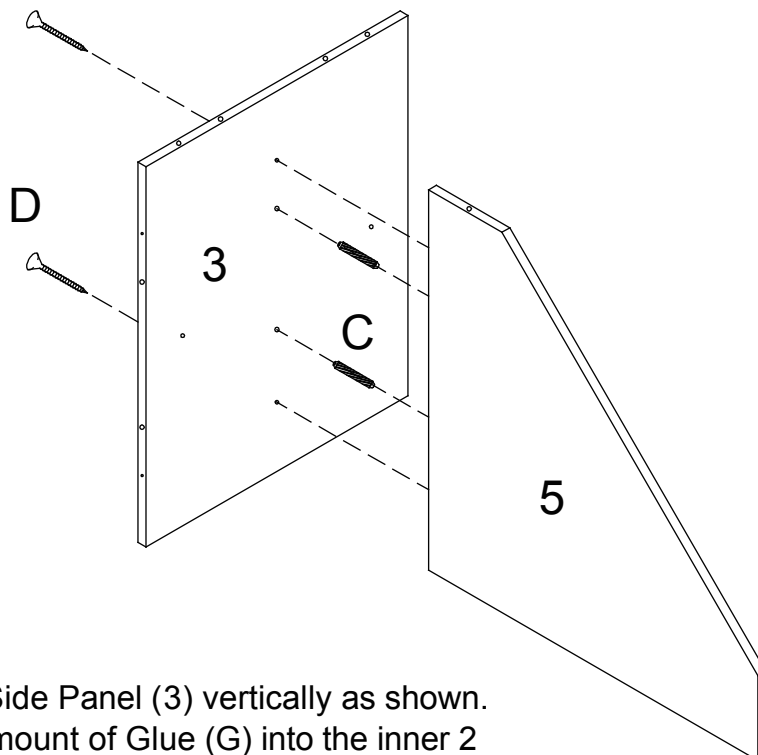
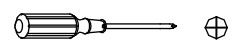



- Position Small Side Panel (3) vertically as shown.
- Apply a small amount of Glue (G) into the inner 2 center holes on (3) and insert Wood Dowel (C).
- Apply a small amount of Glue (G) into the inner 2 center holes at the edge of Shelf (5).
- Attach (5) to (3) via wood dowels.
- Fasten (5) to (3) as shown using Screw (D). Use a Phillips Screwdriver to drive (D).

STEP 3

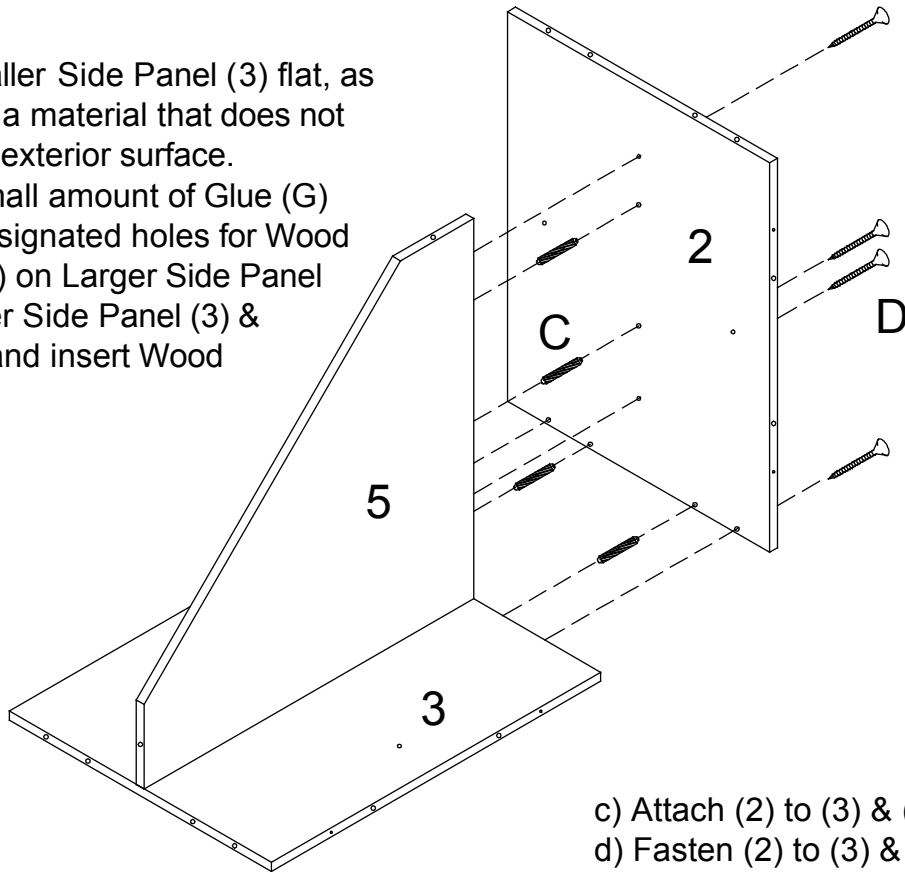
- Place Smaller Side Panel (3) flat, as shown, on a material that does not scratch its exterior surface.
- Apply a small amount of Glue (G) into the designated holes for Wood Dowels (C) on Larger Side Panel (2), Smaller Side Panel (3) & Shelf (5), and insert Wood Dowels.



| | | |
|---|---|-------|
| D |  | 4 pcs |
| C |  | 4 pcs |

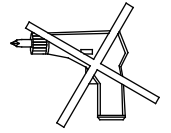

DO NOT USE POWER TOOLS

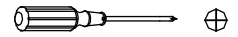



- Attach (2) to (3) & (5) via wood dowels.
- Fasten (2) to (3) & (5) using Screw (D) as shown. Use a Phillips Screwdriver to drive (D).

STEP 4

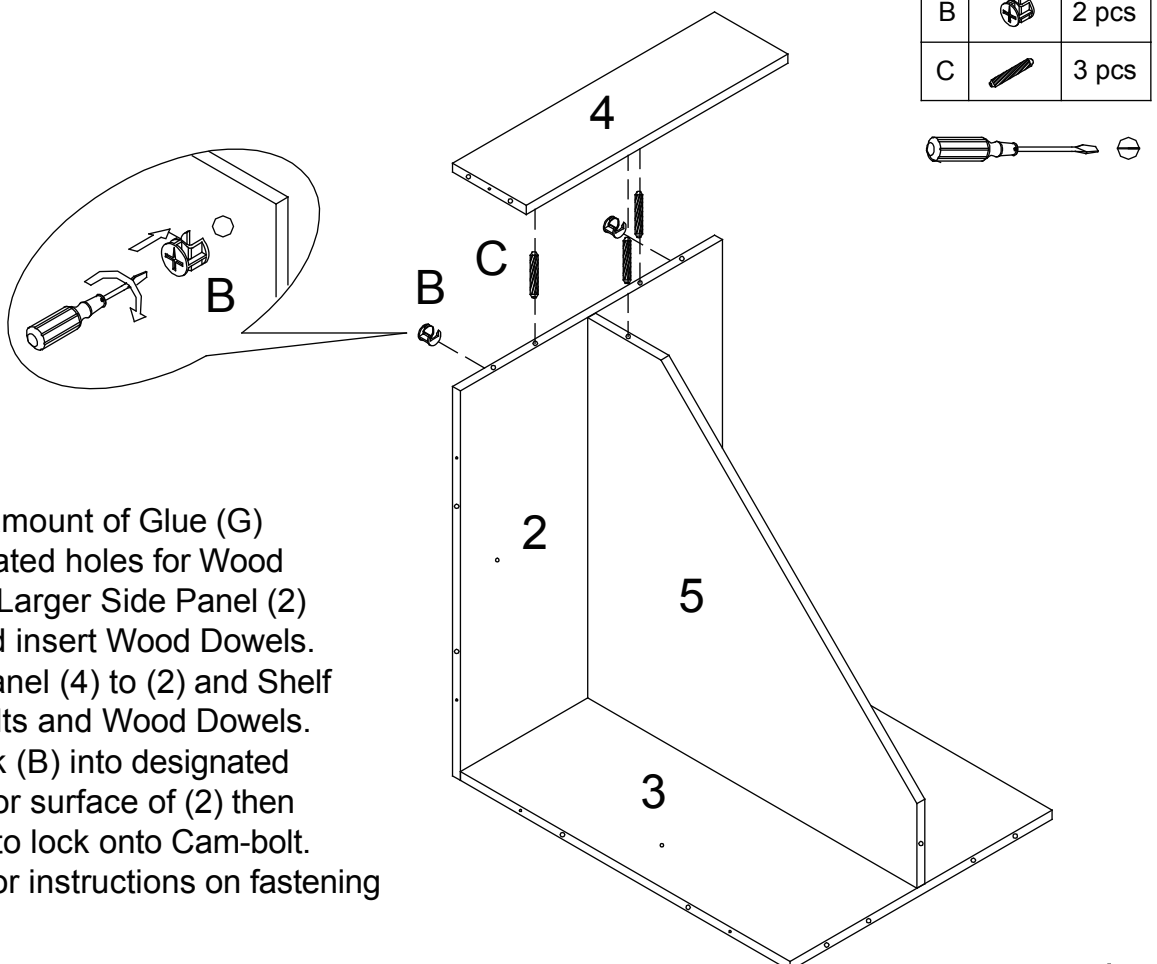
- Apply a small amount of Glue (G) into the designated holes for Wood Dowels (C) on Larger Side Panel (2) & Shelf (5), and insert Wood Dowels.
- Attach Front Panel (4) to (2) and Shelf (5) via Cam-bolts and Wood Dowels.
- Insert Cam-lock (B) into designated holes on exterior surface of (2) then turn clockwise to lock onto Cam-bolt. Refer Page 4 for instructions on fastening Cam-locks.



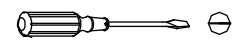

| | | |
|---|---|-------|
| B |  | 2 pcs |
| C |  | 3 pcs |

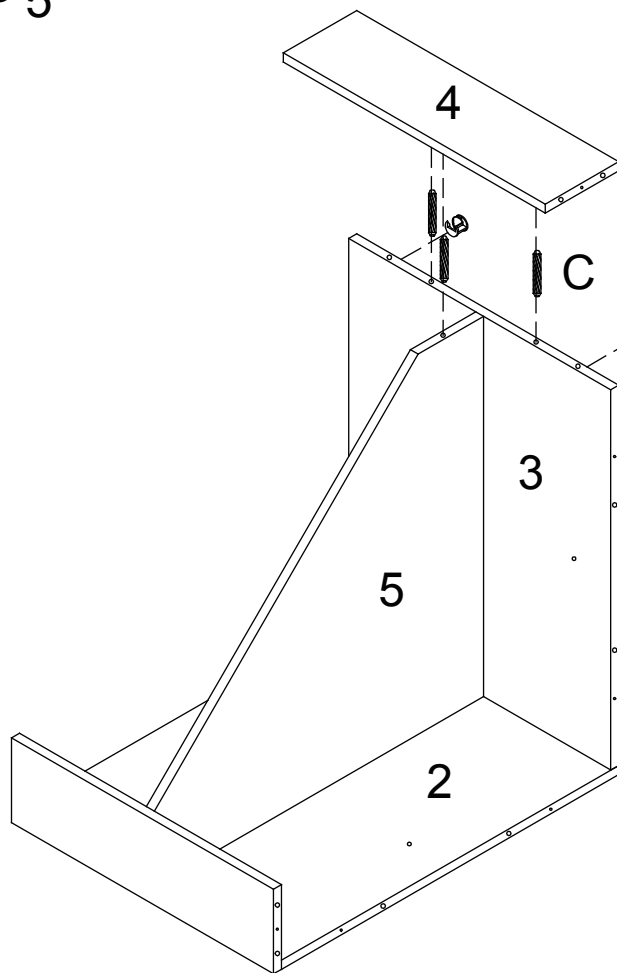

STEP 5





| | | |
|---|---|-------|
| B |  | 2 pcs |
| C |  | 3 pcs |

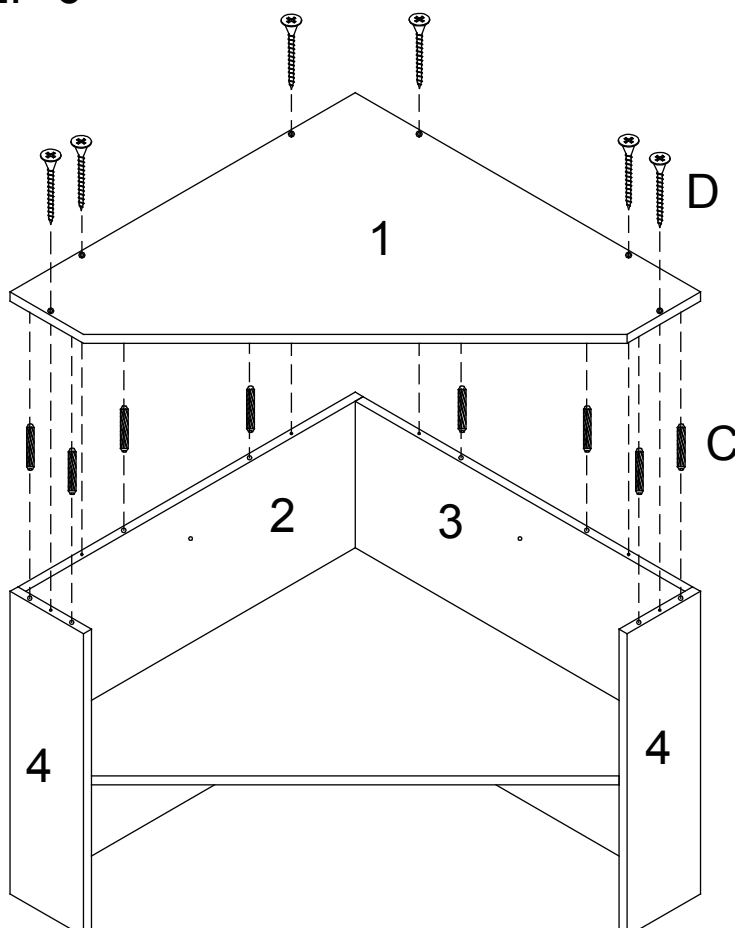

- Place Larger Side Shelf (2) flat, as shown, on a material that does not scratch its exterior surface.
- Apply a small amount of Glue (G) into the designated holes for Wood Dowels (C) on Smaller Side Panel (3) & Shelf (5), and insert Wood Dowels.
- Attach Front Panel (4) to (3) and Shelf (5) via Cam-bolts and Wood Dowels.
- Insert Cam-lock (B) into designated holes on exterior surface of (3) then turn clockwise to lock onto Cam-bolt.

STEP 6



| | | |
|---|---|-------|
| D |  | 6 pcs |
| C |  | 8 pcs |

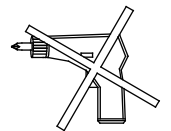

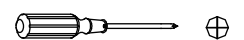

DO NOT USE POWER TOOLS

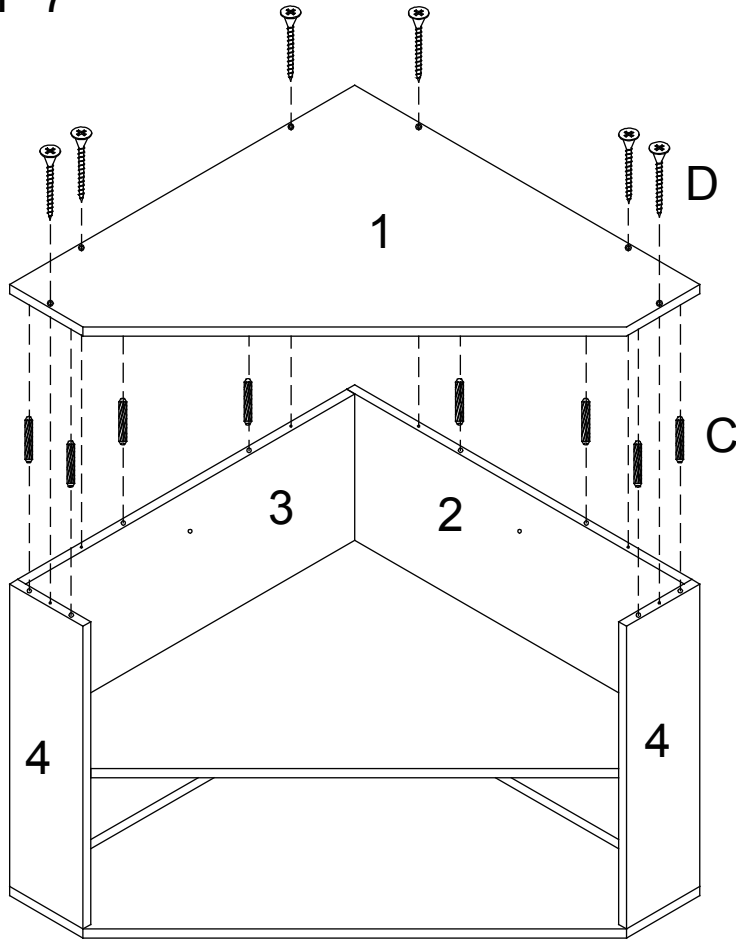

- Place the assembly from Step 5 as shown.
- Apply a small amount of Glue (G) into the designated holes for Wood Dowels on the top edge of each vertical Panels (2, 3 & 4) and insert Wood Dowels.
- Attach 1xLarge Panel (1) to (2, 3 & 4) via Wood Dowels.
- Use a Phillips Screwdriver to drive Screw (D) to fasten (1) to (2, 3 & 4).

STEP 7



| | | |
|---|---|-------|
| D |  | 6 pcs |
| C |  | 8 pcs |

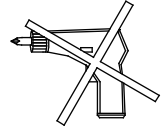

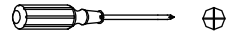

DO NOT USE POWER TOOLS

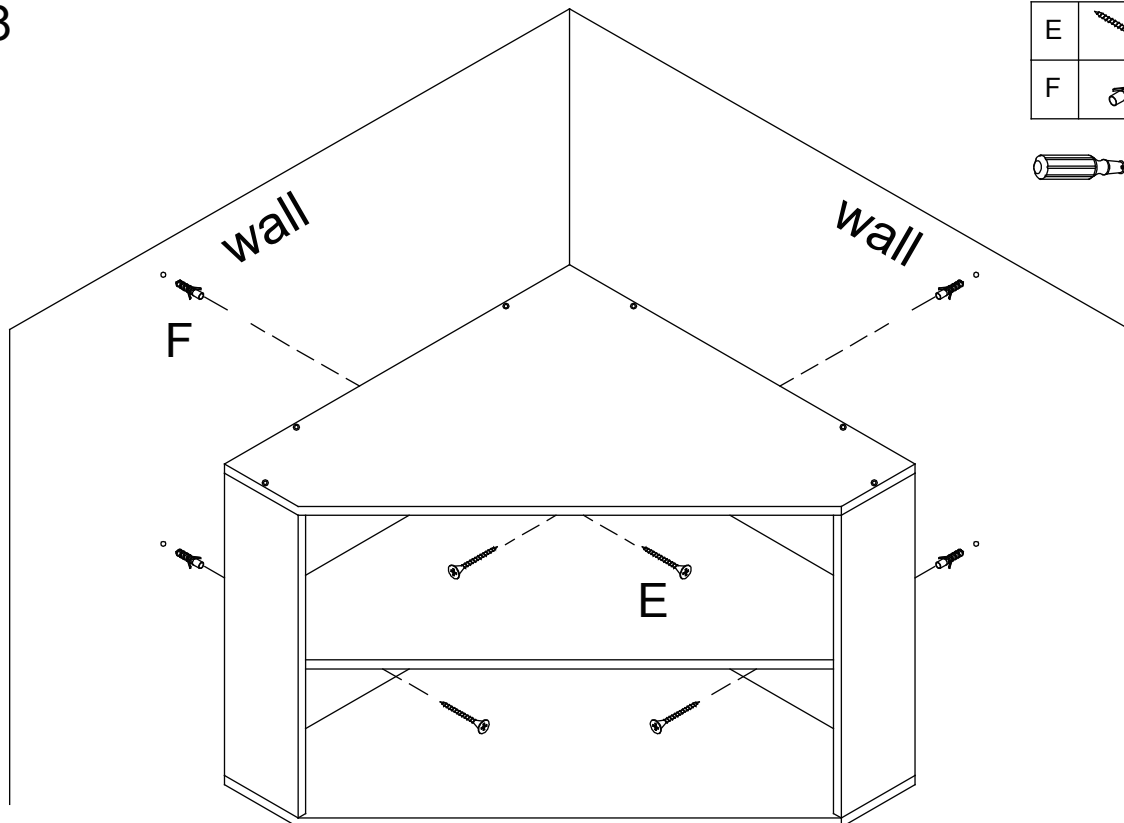

- Invert the assembly from STEP 6.
- Apply a small amount of Glue (G) into the designated holes for Wood Dowels on the top edge of each vertical Panels (2, 3 & 4) and insert Wood Dowels.
- Attach remaining Large Panel (1) to (2, 3 & 4) via Wood Dowels.
- Use a Phillips Screwdriver to drive Screw (D) to fasten (1) to (2, 3 & 4).

STEP 8



| | | |
|---|---|-------|
| E |  | 4 pcs |
| F |  | 4 pcs |



- Marked 4x anchoring positions on the wall to drill a 7/32" holes to insert Plastic Wall Anchor (F). Ensure that the anchor fits snugly in the drilled holes.
- Use Screw (E) to secure the corner hutch to the wall Anchors (F).

The assembly of the corner hutch is complete.