

# ASSEMBLY INSTRUCTION

Thank you for purchasing this quality product. Be sure to check all packing material carefully for small parts which may have come loose inside the carton during shipment. Separate, identify and count all parts and hardware. Compare with the parts list to be sure all parts are present.

**IMPORTANT : PLEASE READ INSTRUCTION BEFORE STARTING THE ASSEMBLY.**

**"DO NOT TIGHTEN SCREWS UNTIL COMPLETELY ASSEMBLED"**

**"DO NOT OVERTIGHT ANY HARDWARE"**

**WARNING : SMALL PARTS AND HARDWARE NOT FOR CHILDREN UNDER 3 YEARS. ADULT ASSEMBLY REQUIRED.**

## TABLE OF CONTENTS

HARDWARES LIST

PAGE 2

PARTS LIST

PAGE 3 - 4

PARTS' LOCATION

PAGE 5

ASSEMBLY STEPS

PAGE 6 - 9

ASSEMBLY COMPLETED

PAGE 9

## ASSEMBLY TOOLS REQUIRED

### **1. Screwdriver (not provide)**

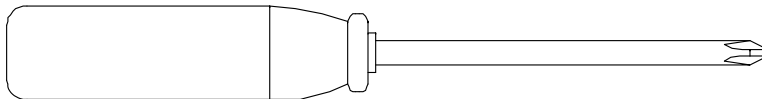



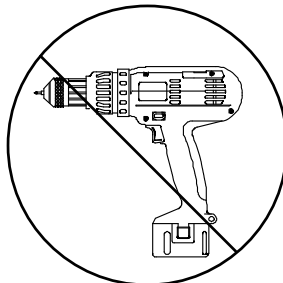

Skip the power trip this time.

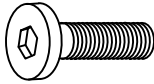
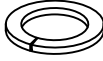
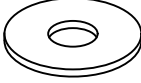

# ASSEMBLY INSTRUCTION

## HARDWARES LIST

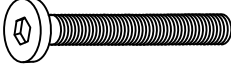
ITEM	DESCRIPTION	DRAWING	QTY
A	JCBB SCREW M8 x 20MM		8 PCS
D	SPRING WASHER M6 x 13MM		22 PCS
E	FLAT WASHER M6 x 19MM		22 PCS
F	CSK C/B SCREW (M4 x 32MM)		8 PCS
G	M4 ALLEN KEY (65MM)		1 PC
H	M5 ALLEN KEY (65MM)		1 PC
I	JCBC SCREW M6 x 40MM (BLACK)		18 PCS
J	JCBB SCREW M6 x 45MM		12 PCS

# ASSEMBLY INSTRUCTION

## PARTS LIST (BOX 1)

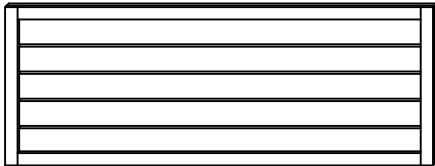
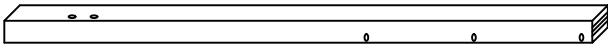
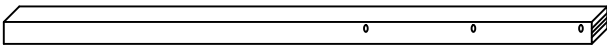
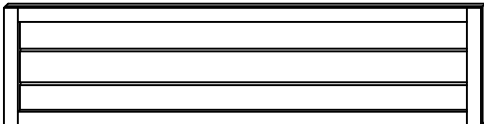
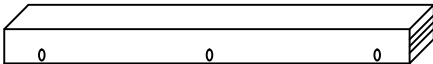
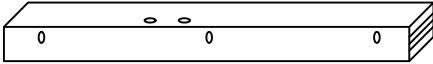
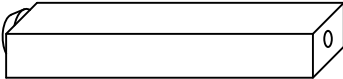
ITEM	DESCRIPTION	DRAWING	QTY
1	HEADBOARD		1 PC
2	HEADBOARD SUPPORT RAIL(R)		1 PC
3	HEADBOARD SUPPORT RAIL(L)		1 PC
5	FOOTBOARD		1 PC
6	FOOTBOARD SUPPORT RAIL(R)		1 PC
7	FOOTBOARD SUPPORT RAIL(L)		1 PC
10	CENTRE SUPPORT LEG		8 PCS

# ASSEMBLY INSTRUCTION

## PARTS LIST (BOX 2)

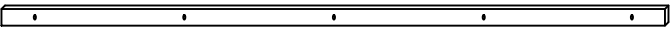
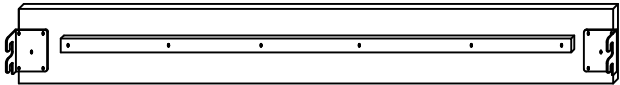
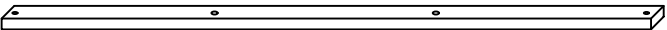
ITEM	DESCRIPTION	DRAWING	QTY
4	HEADBOARD AND FOOTBOARD TOP PANEL		2 PCS
8	SIDE RAIL		2 PCS
9	SLAT		4 PCS

# ASSEMBLY INSTRUCTION

## PARTS ' LOCATION

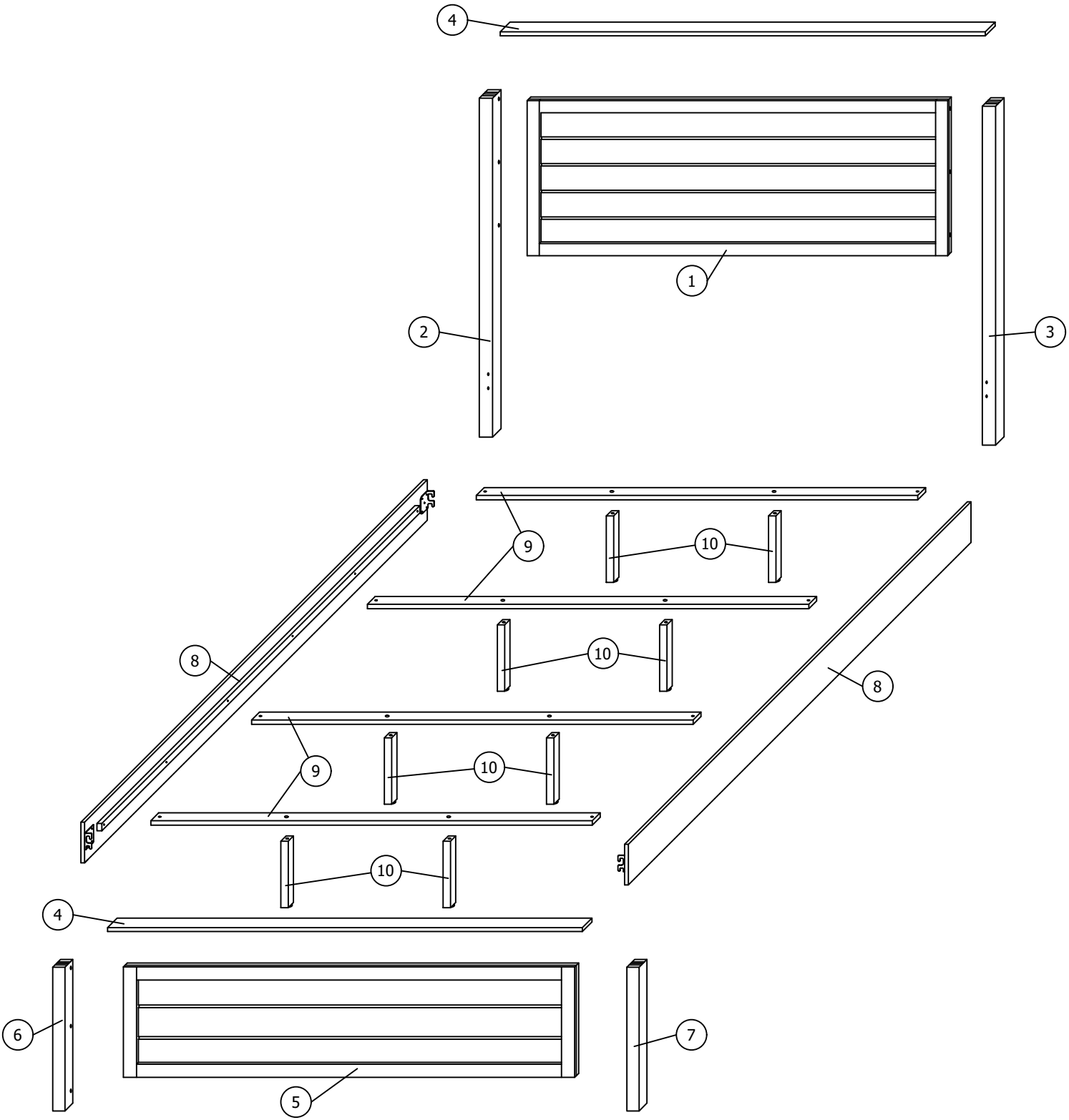

# ASSEMBLY INSTRUCTION

## ASSEMBLY STEPS

### STEP 1

Insert 2 pieces (I) to combine (9) and (10) as shown. This step needs to be **done four times**.

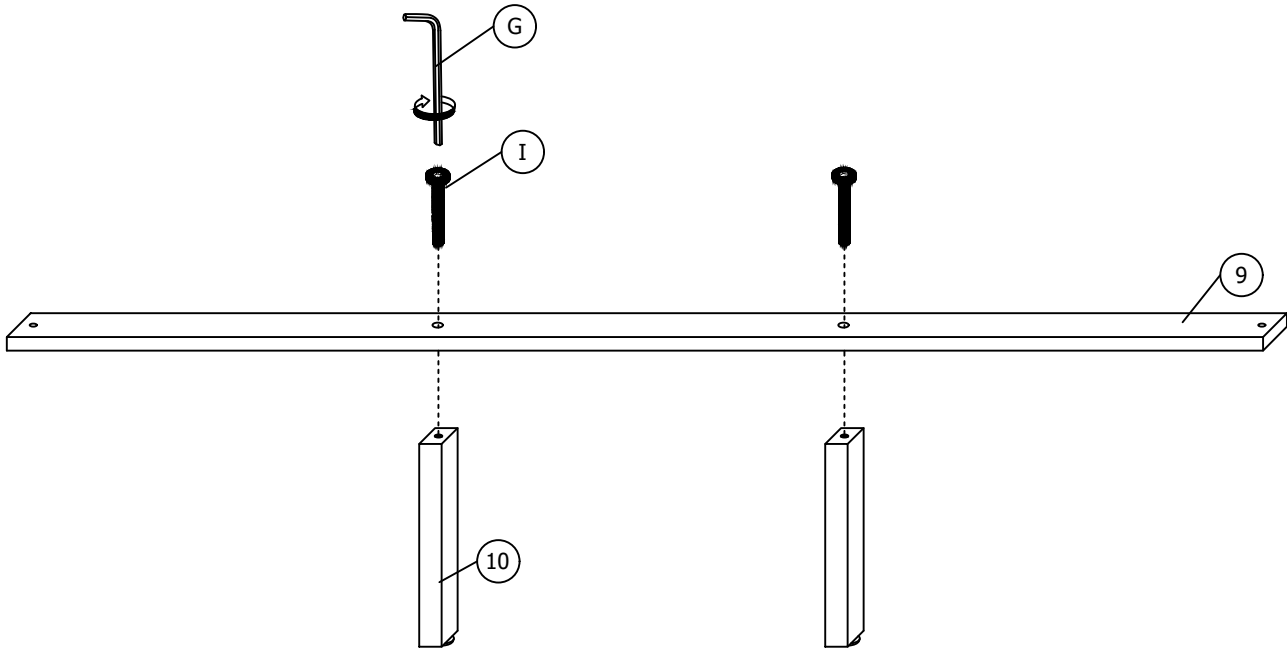

Assembled become like this

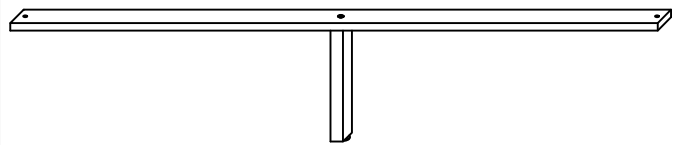

### STEP 2

Insert 5 pieces (I),(D) and (E) to combine (1) and (4) as shown.

Use (I) JCBC SCREW M6 x 40MM (**BLACK**) here.

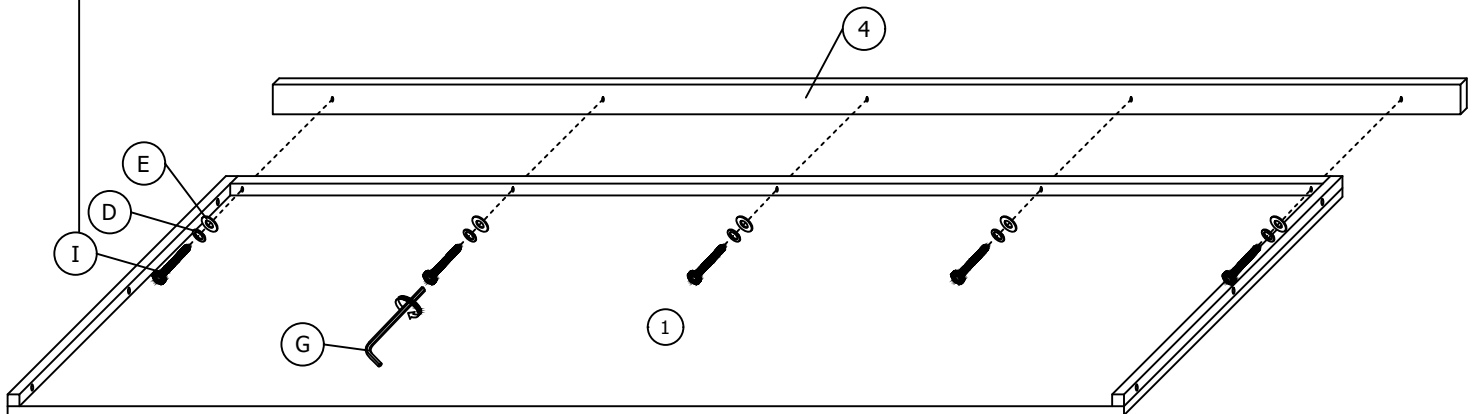

# ASSEMBLY INSTRUCTION

## STEP 3

Insert 6 pieces (J),(D) and (E) to combine the (2) and (3) to the (1) as shown.

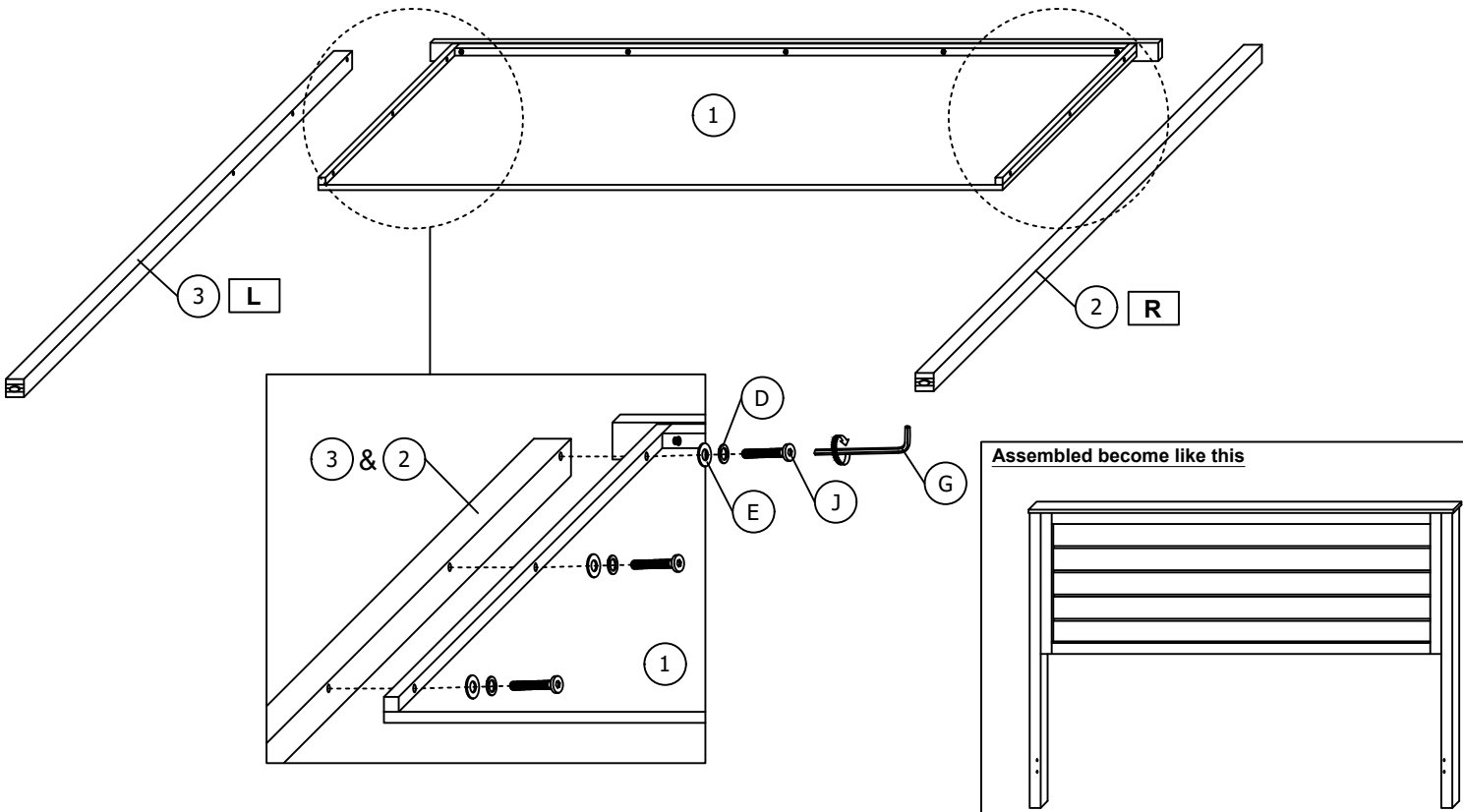

## STEP 4

Insert 5 pieces (I),(D) and (E) to combine (5) and (4) as shown.

Use (I)JCBC SCREW M6 x 40MM (**BLACK**) here.

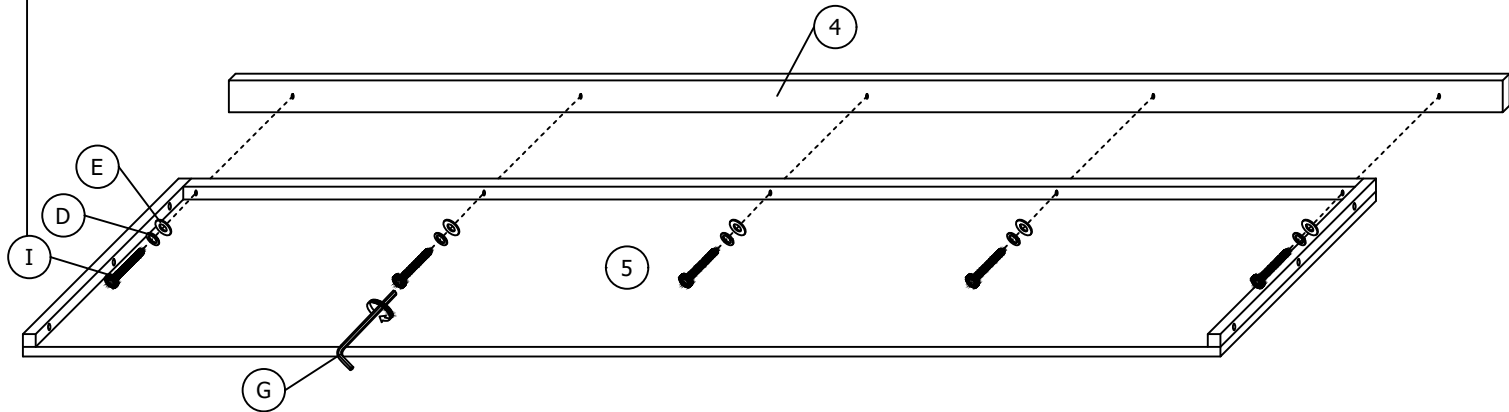

# ASSEMBLY INSTRUCTION

## STEP 5

Insert the remaining 6 pieces (J),(D) and (E) to combine the (6) and (7) to the (5) as shown.

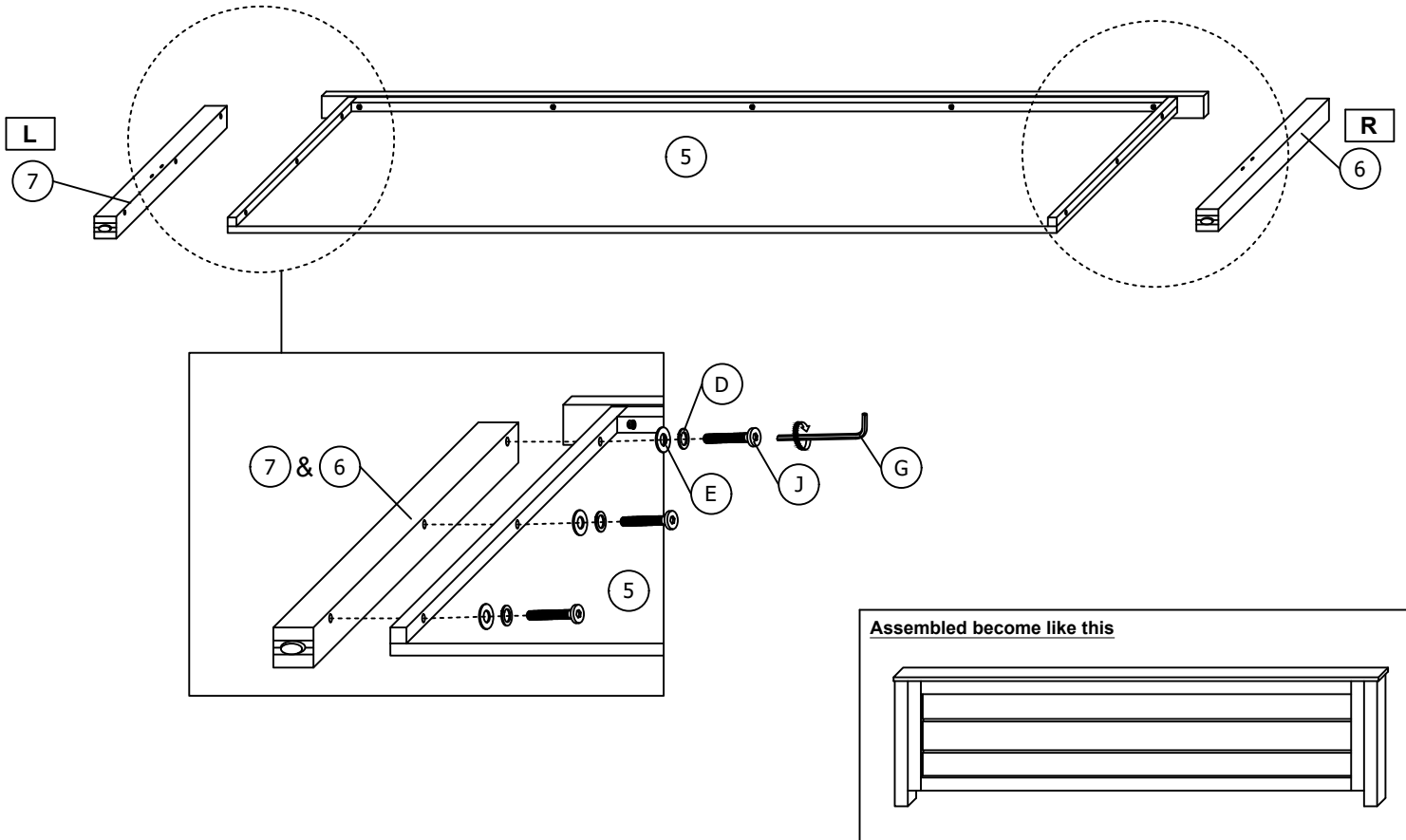

## STEP 6

Insert all the (A) to combine the (2),(3),(6),(7) and (8) as shown.

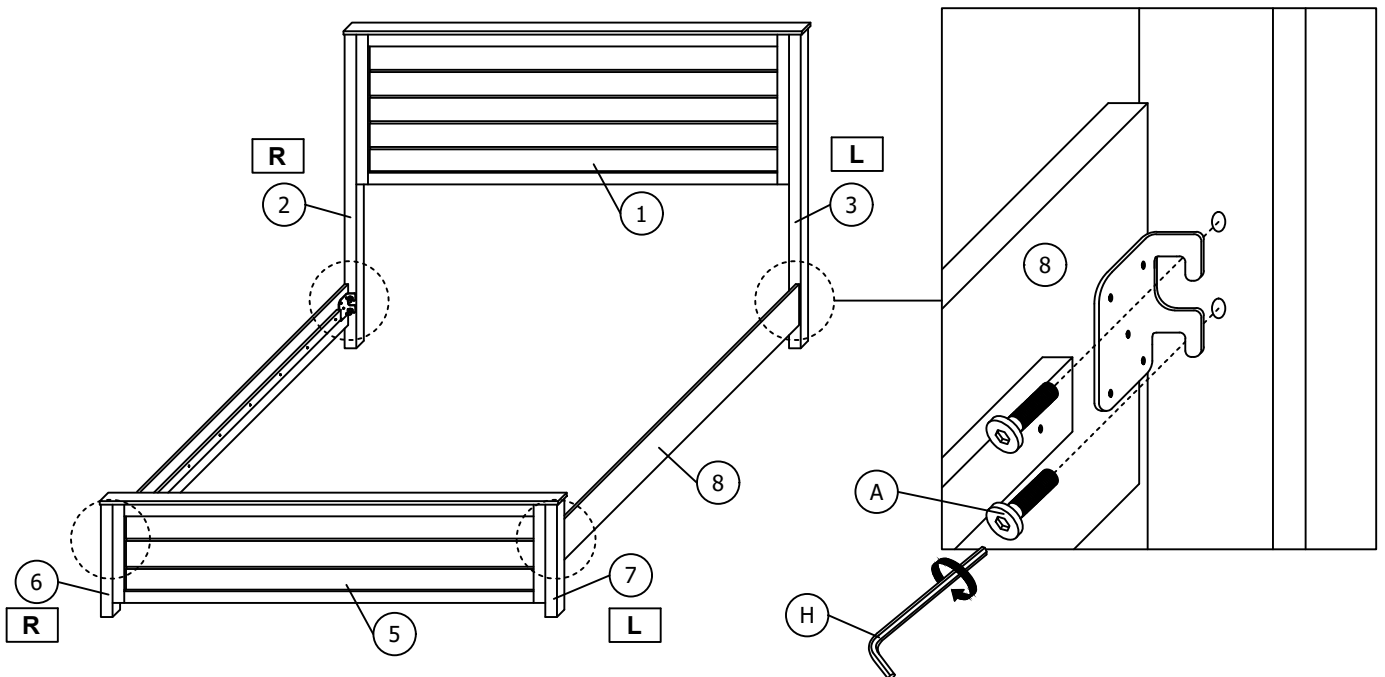

# ASSEMBLY INSTRUCTION

## STEP 7

Put all the (9) and (10)-(combined in step 1) on the wood of (8). Then insert the 8 pieces (F) to fix it.

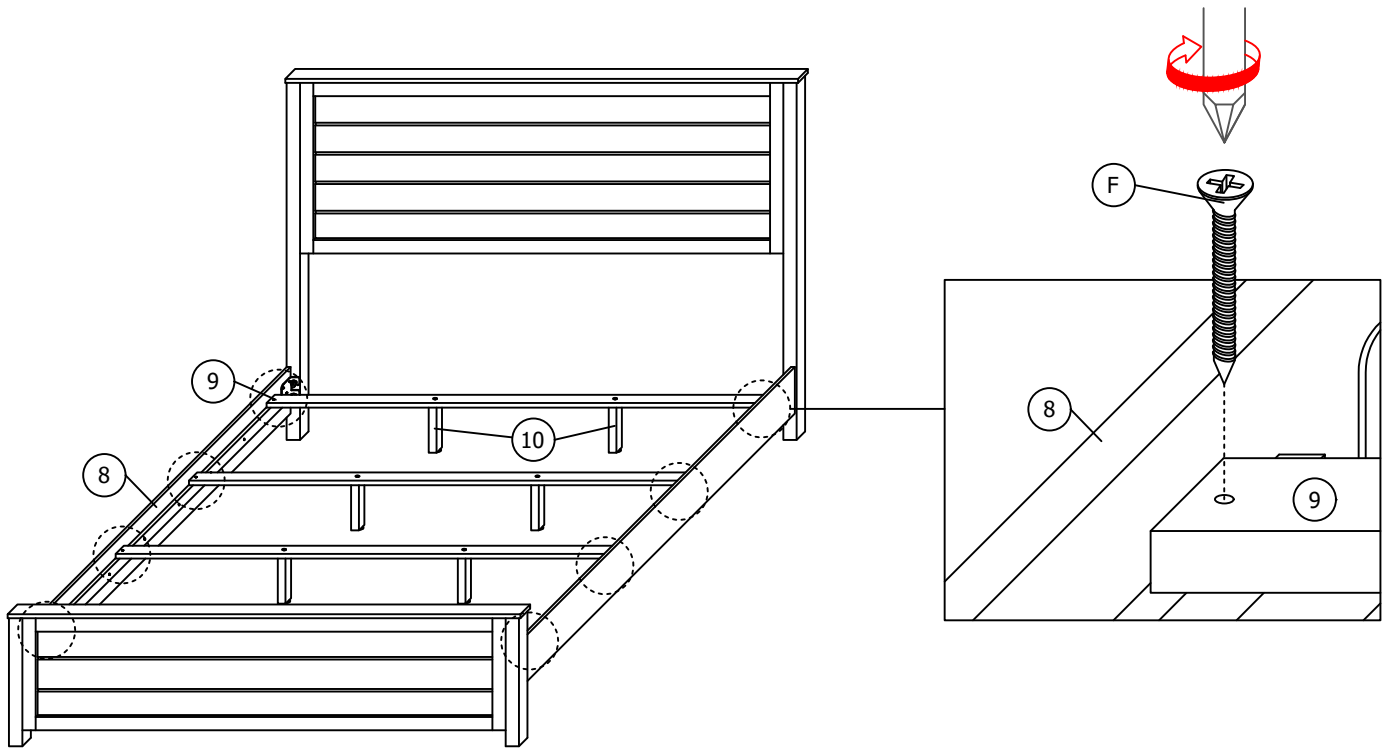

## STEP 8

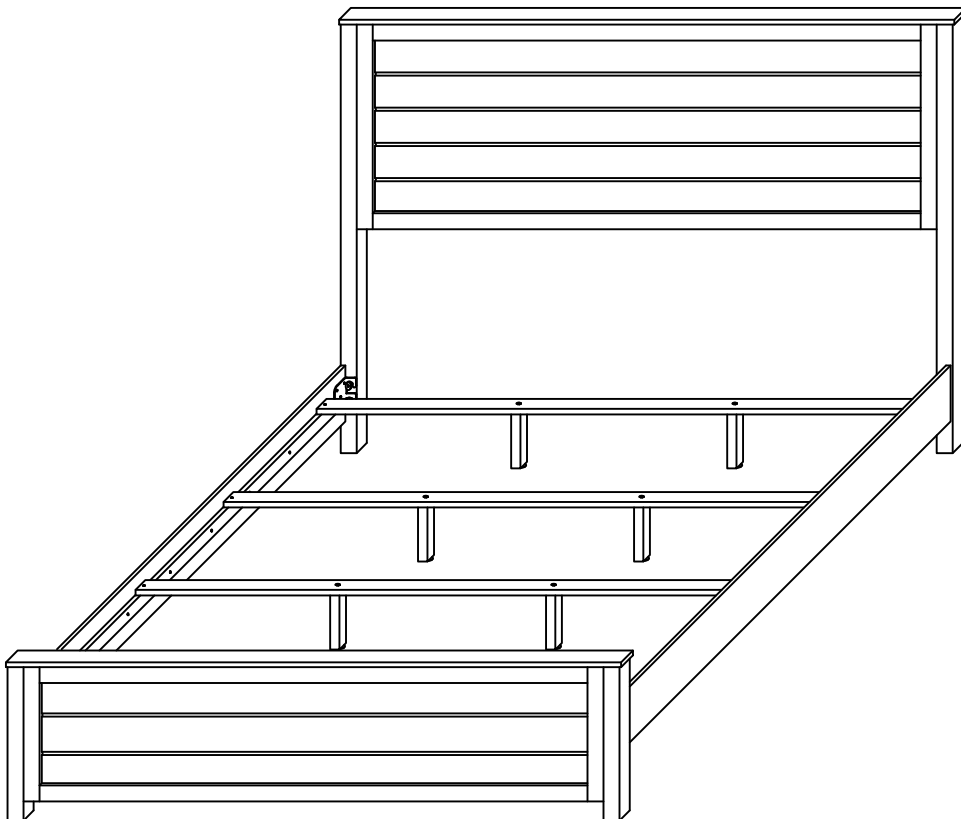

**ASSEMBLY COMPLETED**

\*\* FOR ALL MODEL AND ALL SIZE BED

BOX SPRING

BOX SPRING REQUIRED  
(NOT INCLUDED)

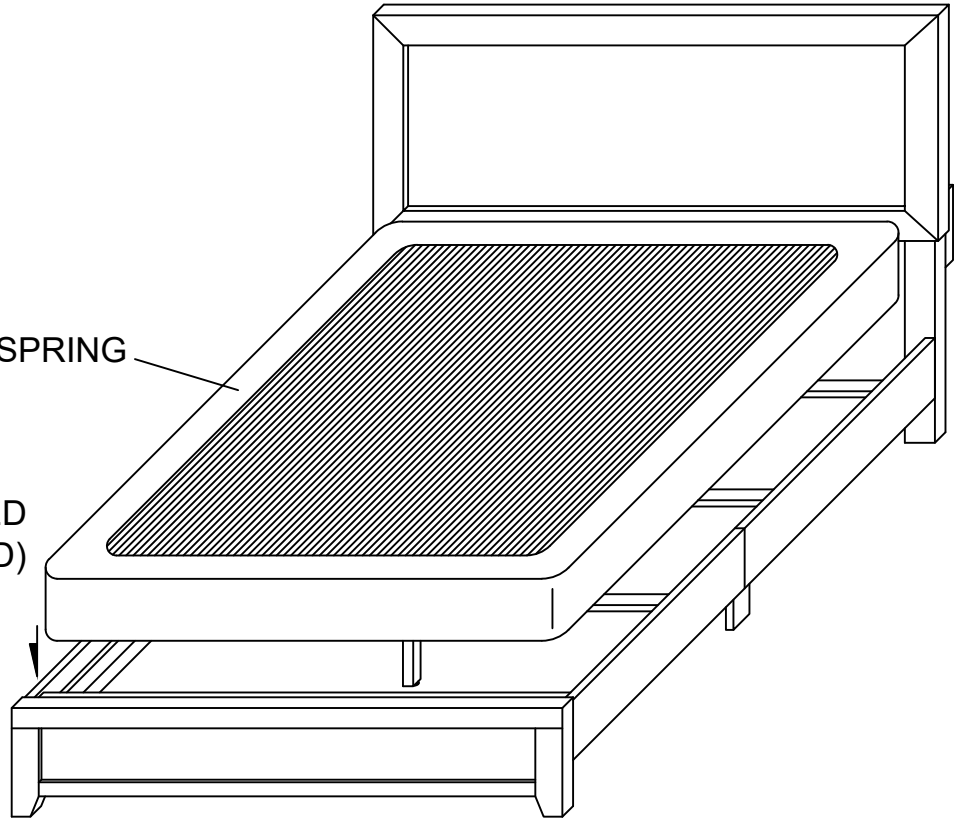

MATTRESS  
(NOT INCLUDED)

