

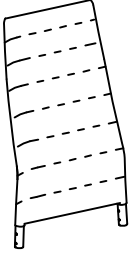

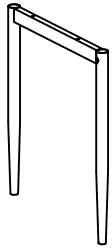

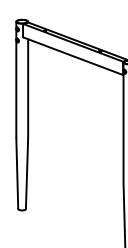

ASSEMBLY INSTRUCTION

1. We suggest that you spend a short time reading through these instructions and follow the sample step by step example.
2. Do not discard any of the packaging until you have checked that you have all the parts and fittings.
3. Assemble this product on a flat surface.
4. Assemble all parts loosely before tightening any bolts.

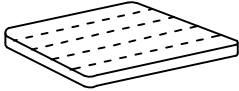
1.- 1 PC. 	2.- 1 PC. 	3.- 1 PC. 	4.- 1 PC. 	5.- 1 PC. 
A. M6 x 40- 2 PCS. 	B. M6 x 15- 4 PCS. 	C. M4- 4 PCS. 	D. M4- 1 PC. 	

STEP 1 : insert the chair back into legs .

STEP 2 : screw inside the legs .

STEP 3 : screw the chair front beam outside the legs.

STEP 4 : screw the seat under two beams .

