

ASSEMBLY INSTRUCTION

IMPORTANT NOTE

- BEFORE BEGINNING ASSEMBLY, check that the quantities of the parts received match those on the parts list below. Carefully remove all the parts from the carton and put them individually on a soft cloth to prevent scratches or other damages occurring to the wood part.
- DO NOT TIGHTEN UP ALL THE BOLTS UNTIL EACH PART IS PROPERLY ASSEMBLED.
- TOOL REQUIRED: Hex Wrench (provided)
- You should keep Hex Wrench in the safe place as you may need to tighten up the Head Cap Bolts periodically in the future.

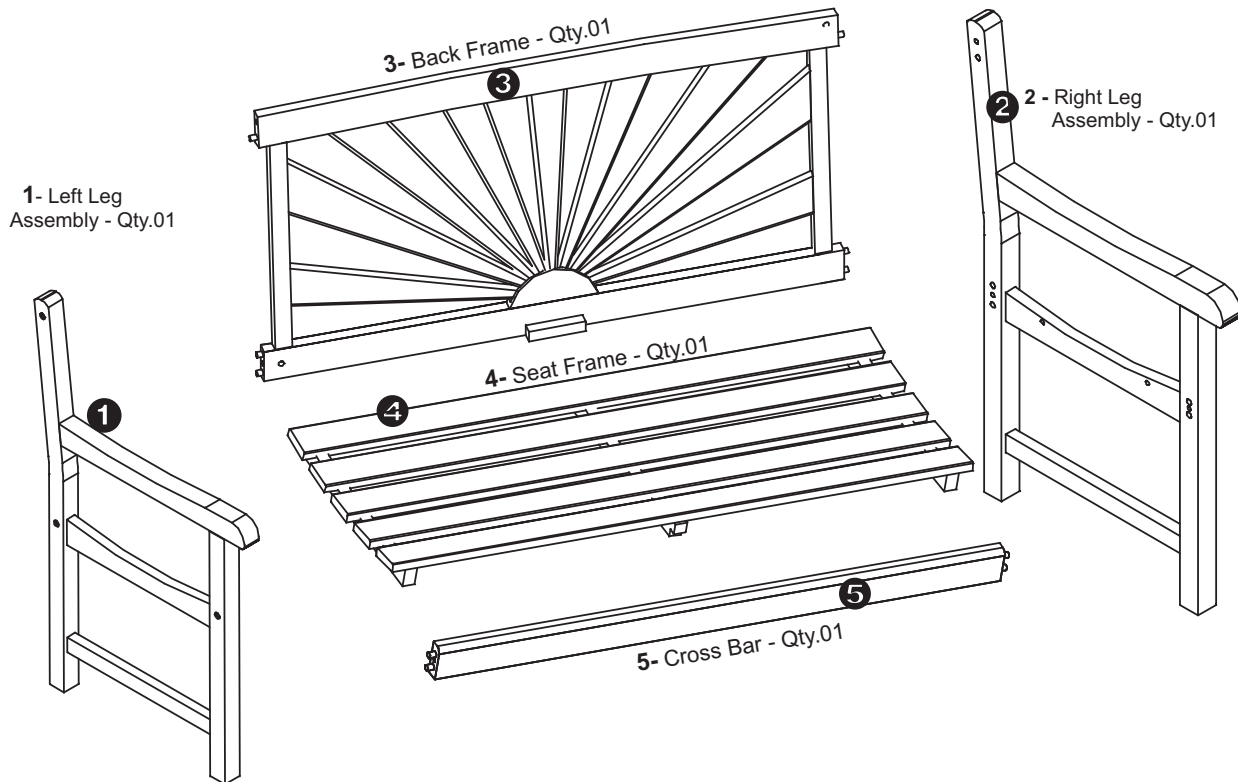

HARDWARE



A - Long Hex Bolt & Barrel Nuts - Qty. 06



B - 30 mm Screw - Qty. 04



C - Hex Wrench - Qty.02

ASSEMBLY INSTRUCTION

DO NOT TIGHTEN UP ALL THE SCREWS UNTIL EACH PART IS PROPERLY ASSEMBLED

STEP 1

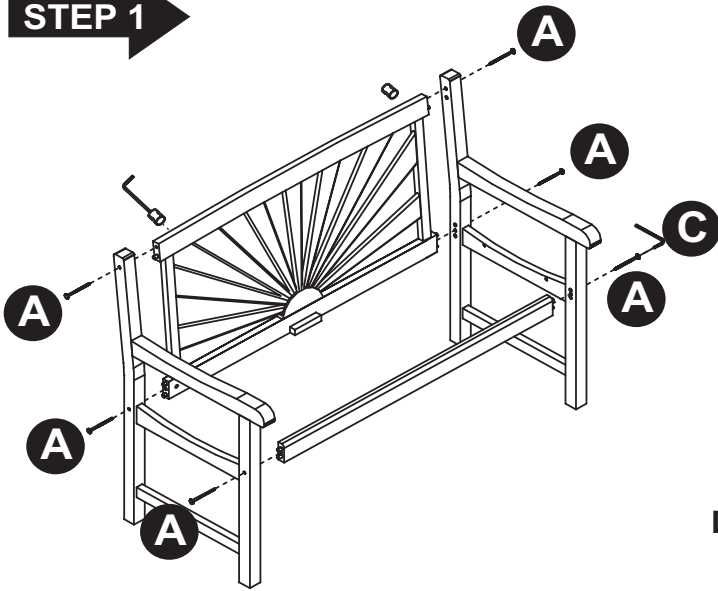

- Place both **Right and Left Legs** at standing up position as shown.
- Secure **Back Frame** and **Cross Bar** into both **Legs** with **6 Long Hex Bolt & Barrel Nuts A** as shown, using an **hex wrench** for **hex bolts** and an **hex wrench** for **barrel nuts**



DO NOT TIGHTEN BOLTS AT THIS STAGE.

STEP 2

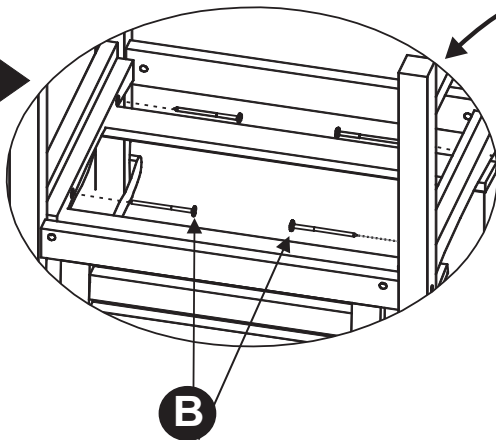

- Carefully place **Seat Frame** upside down as shown
- Attach the **Seat Frame** into both **Legs** by **4 Screws B**
- Tighten carefully 4 Screws at this stage.

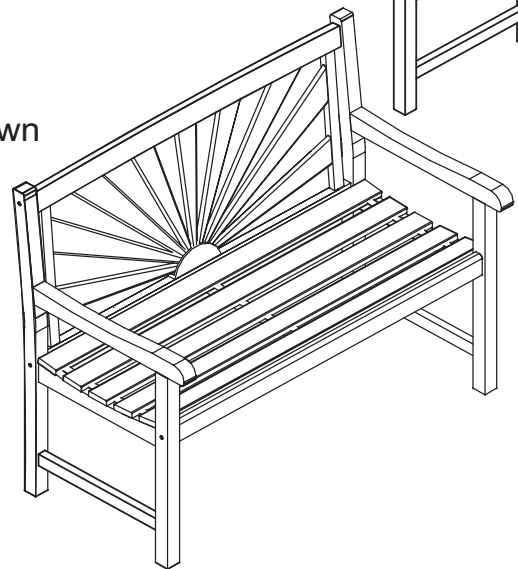
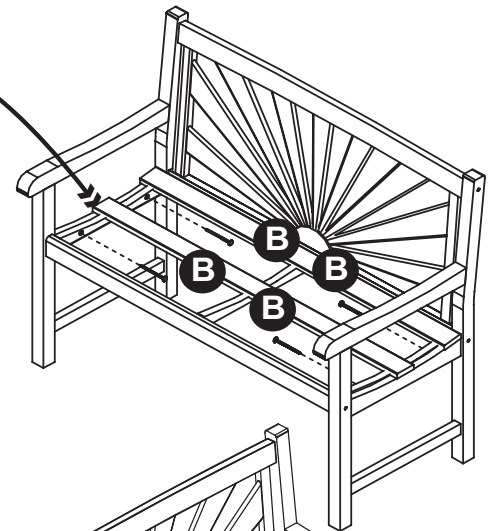

FINALLY TIGHTEN CAREFULLY ALL BOLTS AND SCREWS OF ASSEMBLED ABOVE

Be sure to tighten all Bolts before use