

# **Kräus**<sup>®</sup>

INSTALLATION GUIDE

## **Oletto™ Single Handle Kitchen Bar Faucet**

KPF-2600

## **Congratulations on the purchase of your new Kraus® plumbing fixture!**

Please keep the box and packaging materials until your product is completely installed. If you have any questions, require technical assistance, or have any problems with your product:



**DO NOT RETURN TO STORE**

**Please contact our Customer Service Team  
1-800-775-0703 / [customerservice@kraususa.com](mailto:customerservice@kraususa.com)**

Have the model number available, and retain a copy of your receipt with purchase date for reference.

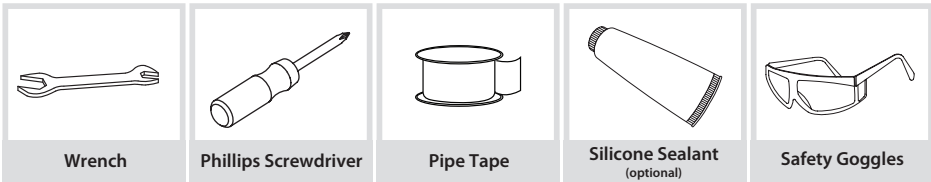
If for any reason this product does not meet your expectations, please be sure to repack this product in the original box and packaging material to avoid damage during transit.

**STOP**

## Prior to Installation:

- Make sure you have all necessary parts by checking the diagram and parts list. If any part is missing or damaged, please contact Kraus® Customer Service at 800-775-0703 for a replacement
- Read all instructions and safety warnings and ensure you have all tools, parts, and equipment necessary for a safe installation.
- Turn off the hot and cold water lines at the angle stops and turn on the old faucet to release any built-up pressure
- Pre-drilled countertop hole size requirement: 1-3/8"(min)
- Max countertop thickness: 2 3/8"

## Tools you will need:



## Care & Maintenance

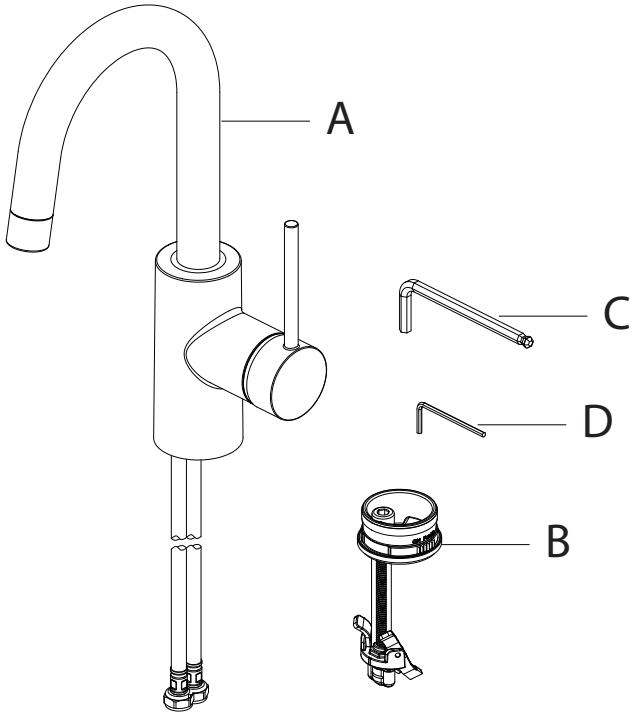
\* To keep the product clean & shining, follow the steps below:

1. Rinse with clean water & dry with a soft cloth
2. Do not clean with soaps, acid, polish, abrasives or harsh cleaners
3. Do not use cloth with a coarse surface
4. Unscrew the aerator and clean when necessary

\* This installation manual is subject to change without further notice.

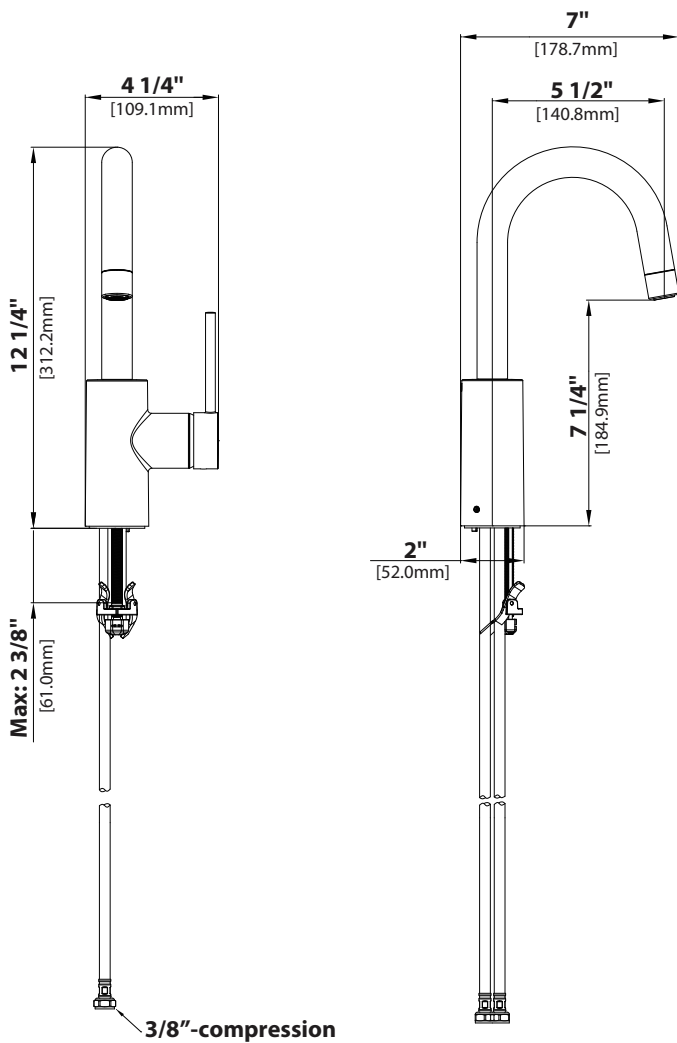


**Diagram and Parts List**



- A. Faucet Body
- B. Easy Install Assembly
- C. 6mm Hex Wrench
- D. 2.5mm Hex Wrench

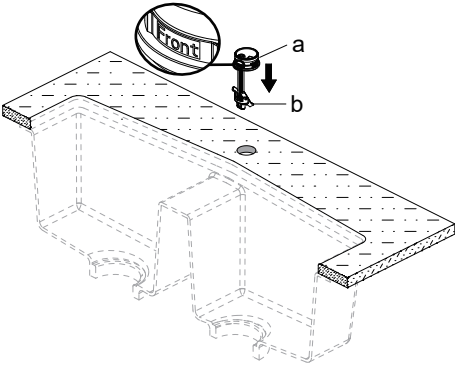
## Faucet Dimension



### Installer Tip:

Shut off main water supply before installing new faucet

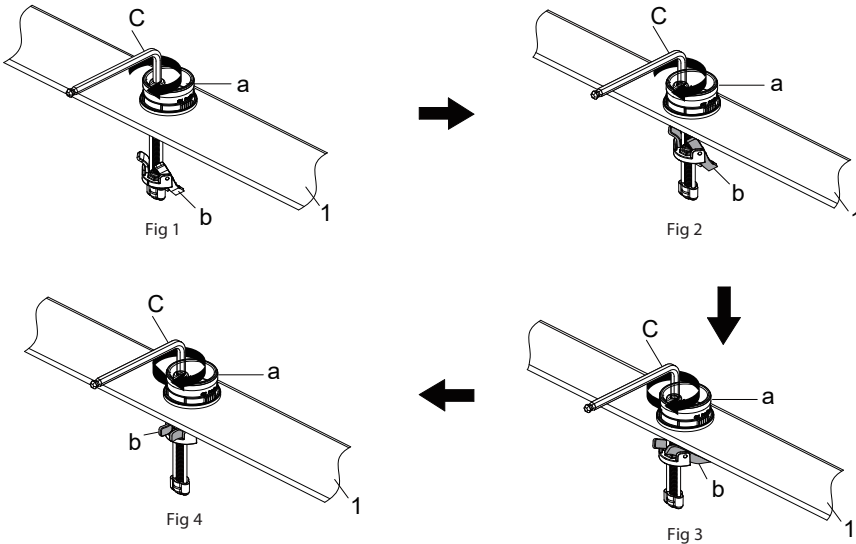
## Step 1: Installing the easy install assembly



Shut off the water supply. Remove the old faucet. Clean the mounting surface. Check for the proper thickness of the sink. Insert the base (a) into sink.

**NOTE:** "Front" on the base (a) must face the front of the sink. The two mounting plates (b) on the base (a) must be loose and movable during the installation of the base (a).

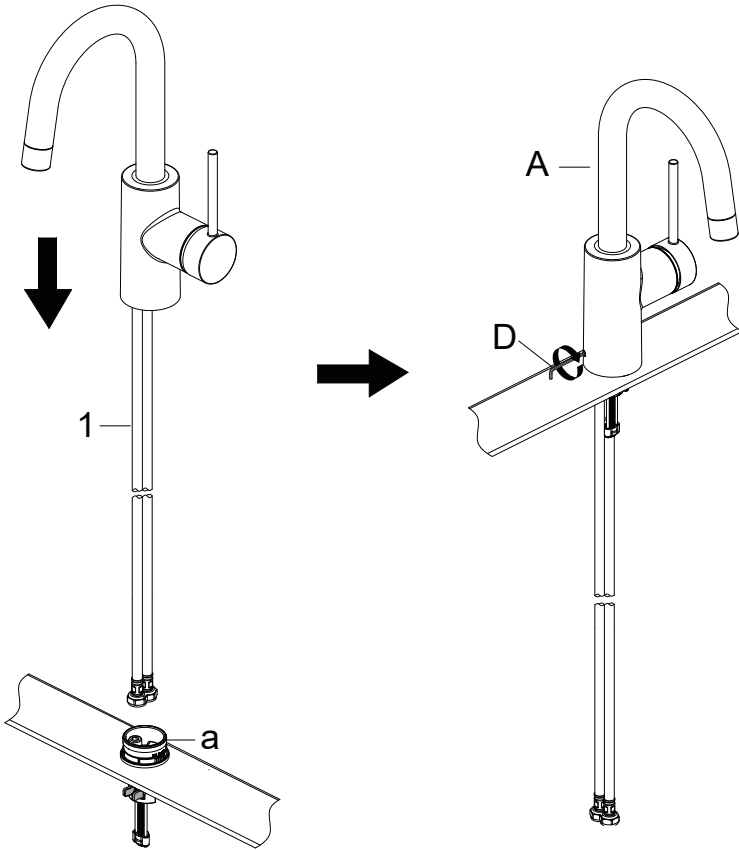
## Step 2: Installing the easy install assembly



Press the base (a) so that it can not move, then turn the screw with the provided hex wrench (C, HEX: 6.0mm) clockwise, as shown Fig 1. When the mounting plates (b) make contact with the sink (1), continue to turn the screw with the provided hex wrench (C, HEX: 6.0mm) clockwise, as shown Fig 2, until the base (a) is completely tightened and secured, as shown Fig.4.

### Step 3: Installing the faucet

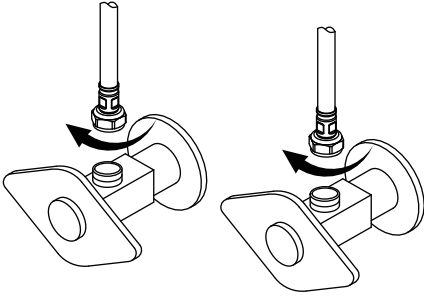
---



Insert the supply lines (1) through the hole of the base (a). Carefully insert the hoses into the base. Place the faucet assembly (A) onto the base (a) as shown in the above figure. Secure the faucet assembly (A) by tightening the set screw with the provided hex wrench (D, Hex: 2.5 mm).

## Step 4: Connect waterlines to main valve

---

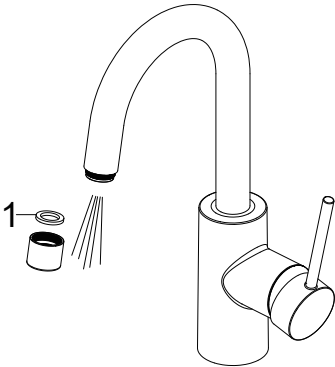


Attach waterlines to angle stops and tighten until snug. Turn on angle stops and check for leaks (DO NOT TURN FAUCET ON).

**NOTE:** Please make sure filter washers are installed before connecting to the main valve.

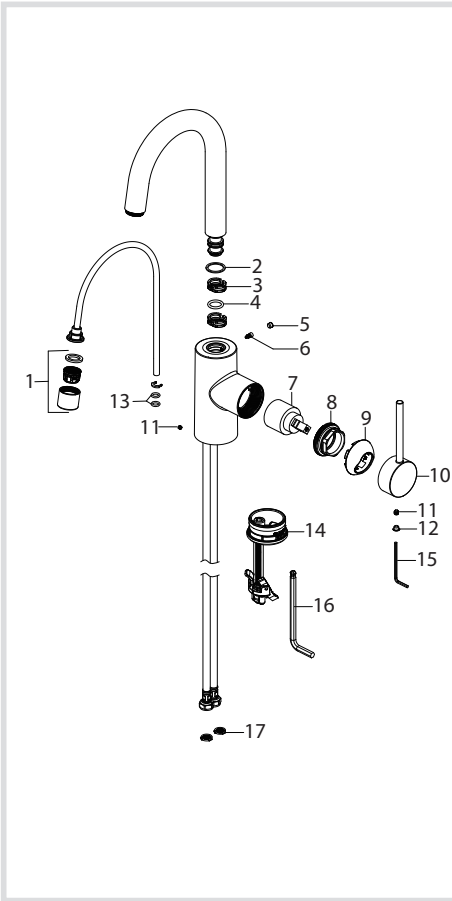
## Step 5: Flush faucet

---



After installing faucet, remove aerator. Turn water on for 30 seconds to remove any debris. Reassemble aerator. Do not lose the gasket (1) in the aerator.

## Replacement Parts



Replacement Parts List	Finish / Color	Part #
1. Aerator Assembly	CH, SFS, MB, BB, SFACB*	KP27295
2. Washer	GR, BL*	KP27031
3. Block		KP27030
4. O-ring		KP27029
5. Index	GR, BL*	KP27222
6. Set Screw		KP27033
7. Cartridge		KP27257
8. Bonnet Nut		KP27258
9. Cap	CH, SFS, MB, BB, SFACB*	KP27259
10. Handle	CH, SFS, MB, BB, SFACB*	KP27260
11. Set screw		KP27001
12. Cover Button	GR, BL*	KP27002
13. O-Ring Set of 2		KP27171
14. Easy Install Assembly		KP27262
15. Hex wrench		KP27020
16. Hex Wrench		KP27263
17. Filter Washer		KP27167

\*Denotes faucet component color options:

SFS - Spot Free Stainless Steel;

CH - Polished Chrome;

GR - Grey; BL - Black;

MB - Matte Black;

BB - Brushed Brass;

SFACB - Spot Free Antique Champagne Bronze

## Troubleshooting

If you have followed the instructions carefully and your faucet still does not work properly, take the following coorrective steps:

PROBLEM	CAUSE	ACTION
Leakage under the handle	Bonnet nut (8) has come loose	Remove the cover button (12). Loosen set screw (11) with hex wrench (15). Remove the handle (10) and cap (9) . Tighten bonnet nut (8) with an adjustable wrench
The aerator has an irregular or reduced water flow	The aerator is dirty or mis-fitted	Remove the aerator and check for debris. Ensure that the rubber washer is properly installed.
Water will not shut off completely	Cartridge may need to be adjusted or replaced	Remove the cover button (12). Loosen set screw (11) with hex wrench (15). Remove the handle (10) and cap (9). Tighten bonnet nut (8) with an adjustable wrench. Remove the cartridge (7). Check for cracks
There is a low flow of water.	The filter washer in the hose connectors is dirty.	Turn off the water supply at water valve and unscrew the hose connectors from water supply lines. Clean the filter washer in the water lines with hot water, removing any debris or calcium build up

## Codes/Standards Applicable:



NSF/ANSI 61



ASME A112.18.1  
1.5GPM 5.7L/min maximum

### Faucet - Lifetime Limited Warranty

Kraus® USA Plumbing, LLC ("Kraus") extends this warranty to the original purchaser for personal household use of the Faucet when purchased from an authorized Kraus dealer and in the location of original installation. This warranty is non-transferable.

Kraus warrants the structure and finish of the Faucet to be free from defects in material and workmanship under normal usage for as long as the original purchaser resides in the residence in which the Faucet was first installed.

Kraus warrants the Faucet's sprayhead assembly (including the engine, aerators, structure, restrictors, back flow preventers, sprayer hoses, braided supply line hoses which encompasses nylon, silicon and stainless steel) of the product to be free from defects in material and workmanship under normal usage for a period of one (1) year from the date of purchase.

Kraus warrants the Faucet's cartridge to be free from defects in material and workmanship under normal usage for a period of five (5) years from the date of purchase.

Any product reported to the authorized dealer or to Kraus as being defective within the warranty period will be repaired or replaced with a product of equal value at the option of Kraus.

### Commercial Warranty

Kraus USA Plumbing, LLC ("Kraus") warrants its Products for a period of one (1) year to commercial purchasers of Products used in industrial, commercial and business applications.

### Care and Cleaning Instructions

Certain cleaning products may cause damage to a Product's finish and use of the following on the Product will void this warranty:

- Abrasive cleaners such as powders, bleach, ammonia, alcohol or chlorine
- Abrasive pads, steel wool or wire brushes

### What is Not Covered

This warranty does not cover Products that were discontinued when purchased or display Products, whether such Products were purchased at discount outlets, unauthorized dealers, and/or sold on clearance. This warranty does not cover any free gifts included with purchase.

This warranty does not cover damage resulting from neglect, misuse (including use for an unintended application), abuse, carelessness, accident, hard water or mineral deposits, exposure to corrosive materials, improper maintenance, alteration of the Product, or failure to follow care, cleaning or installation instructions enclosed with your Product. Kraus recommends that all Kraus Products be installed by a fully licensed and insured trade professional with experience in the installation of bathroom and/or kitchen manufactured goods.

### How to Make a Warranty Claim

If you are a **consumer purchaser**, please contact a Kraus® Customer Service Representative at:  
Kraus USA Plumbing, LLC  
12 Harbor Park Drive  
Port Washington, NY 11050  
Toll-free 800-775-0703  
Customerservice@kraususa.com

If you are a **plumbing contractor or trade professional**, please contact a Kraus Pro Representative at:  
Kraus USA Plumbing, LLC  
12 Harbor Park Drive  
Port Washington, NY 11050  
516-801-8955  
Proservice@kraususa.com

If you are an **authorized partner**, please contact a Partner Support Representative at:  
Kraus USA Plumbing, LLC  
12 Harbor Park Drive  
Port Washington, NY 11050  
516-801-8954  
Partnersupport@kraususa.com

In requesting warranty service, please be ready to provide your proof of purchase and a description of the problem. Shipping charges will be covered for the first (1) year of the warranted replacement part or product (HI, AK, and Puerto Rico shipping charges may apply). International shipping fees are not included.

### Limitation on Duration of Implied Warranties

Please note that some states/provinces (including Quebec) do not allow limitations on how long an implied warranty lasts, so the below limitations may not apply to you. TO THE MAXIMUM EXTENT PERMITTED BY APPLICABLE LAW, ANY IMPLIED WARRANTY, INCLUDING THE IMPLIED WARRANTIES OF MERCHANTABILITY AND OF FITNESS FOR A PARTICULAR PURPOSE, IS LIMITED TO THE STATUTORY PERIOD OR THE DURATION OF THIS WARRANTY, WHICHEVER IS SHORTER.

### Limitation of Special, Incidental or Consequential Damages

Please note that some states/provinces (including Quebec) do not allow the exclusion or limitation of special, incidental or consequential damages, so the below limitations and exclusions may not apply to you. TO THE MAXIMUM EXTENT PERMITTED BY APPLICABLE LAW, THIS WARRANTY DOES NOT COVER, AND KRAUS USA PLUMBING, LLC SHALL NOT BE LIABLE FOR, ANY SPECIAL, INCIDENTAL OR CONSEQUENTIAL DAMAGES (INCLUDING LABOR CHARGES TO REPAIR, REPLACE, INSTALL OR REMOVE THIS PRODUCT), WHETHER ARISING OUT OF BREACH OF ANY EXPRESS OR IMPLIED WARRANTY, BREACH OF CONTRACT, TORT, OR OTHERWISE.

This warranty gives you specific legal rights, and you may also have other rights which vary from state/province to state/province.

**Download the Kraus Care & Maintenance Guide at:**  
<http://www.kraususa.com/maintenance>

# IMPORTANT

## Register Your Kraus Product

**Activate** Your Warranty

**Access** Premium Customer Support

**Get** Product Information

**REGISTER TODAY**

<http://www.kraususa.com/registration>



**Kräus**<sup>®</sup>  
www.kraususa.com