

ASSEMBLY INSTRUCTIONS

TOOLS REQUIRED



Allen Wrench

(Included)



Phillips
Screwdriver

(Not Included)



3 - People
Recommended

ASSEMBLY RATING



EASY —————> DIFFICULT

The Assembly Rating is a 5-point system showing the level of effort needed to assemble a specific product.

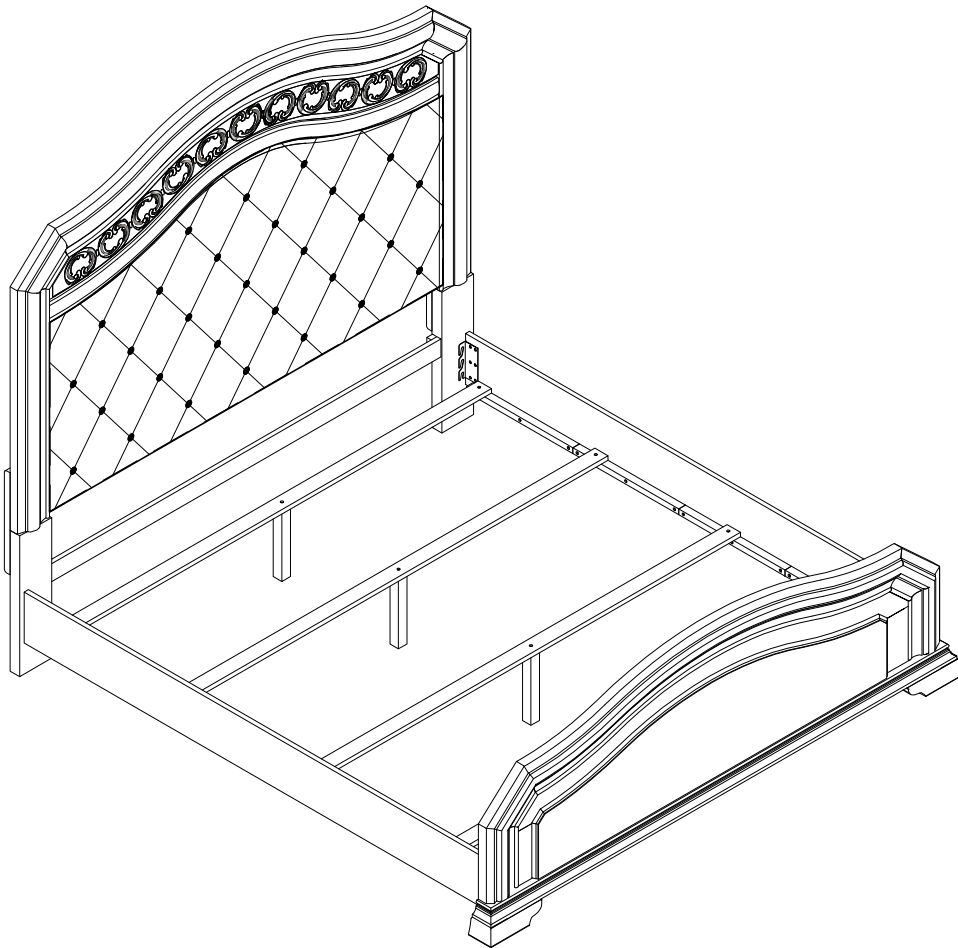



CHECK BEFORE STARTING

Are you missing anything?

Double-check all parts, hardware and accessories listed on Page 6 are accounted for.

Should we send any replacements?

Are there any irregularities or flaws in the parts? We can send replacements!

Check out our Quick Tips!

We recommend reviewing the pre-assembly handouts. Even experts need a refresher now and then!

Prep Time!

Please review the assembly instructions and all diagrams prior to assembling. Arrange parts as recommended on Page 7 and group identical hardware together to make assembling easier.

PRE ASSEMBLY INTRODUCTION

We understand building ready-to-assemble furniture can be a challenging experience for some. To help avoid confusion, we have provided some helpful tips that may speed up the process.



Teamwork

ALWAYS have at least two people to help with transporting and assembling the product to avoid potential injury and/or damage.



Suitable Location

Assembling near the area of the intended location is highly recommended.



Sufficient Space

Make sure you have enough space to move around during the assembly.



Avoid Scratches

Use cardboard, blankets or a carpeted area while assembling furniture to prevent scratches.



Flat Surface

Make sure the furniture rests on a flat and level surface with each leg evenly touching the floor.

ASSEMBLY AND CARE ADVICE



FAILURE TO FOLLOW THE GUIDELINES BELOW MAY RESULT IN INJURY AND/OR PROPERTY DAMAGE.



Position each part correctly and insert screws or bolts into their respective holes.

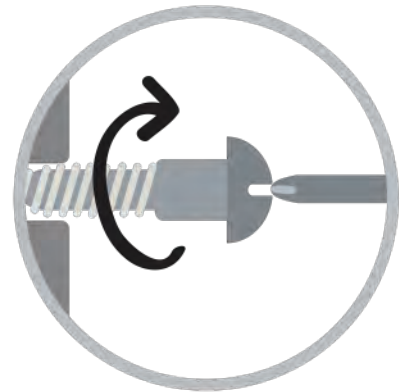

Turn clockwise to tighten and only tighten when step is completed or when instructed to do so.



Use the appropriate hand tools or power tools for assembly. Select steps, such as tightening screws and/or bolts, may require hand tools to avoid causing damage during assembly.



Save the instructions and store any supplied tools for later maintenance.

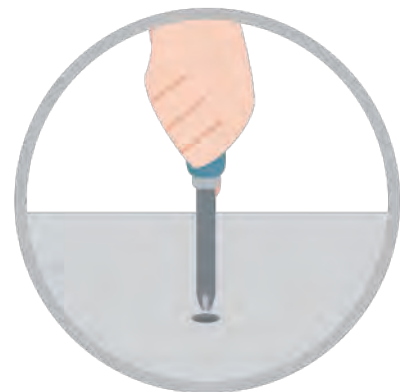



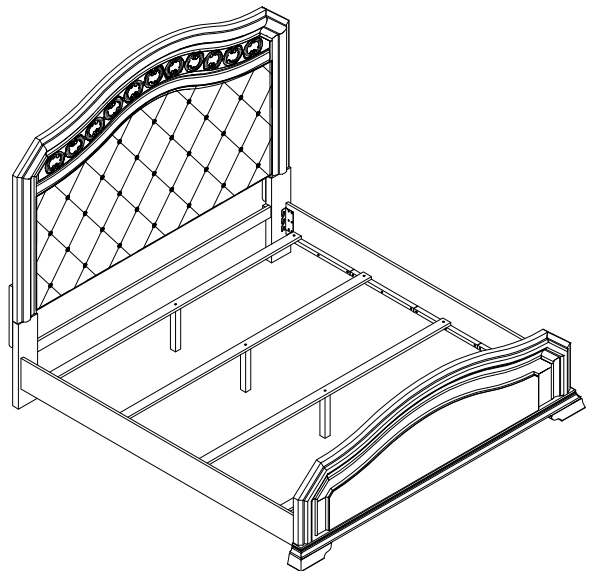
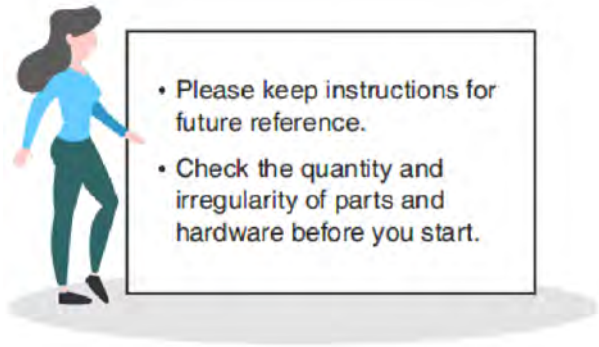

After two weeks, check and tighten any loose hardware and repeat again every six months thereafter.

IT IS THE USER'S RESPONSIBILITY TO MAINTAIN THE FURNITURE. THE HARDWARE MAY LOOSEN OVER TIME AND MAY CAUSE THE FURNITURE TO BE WOBBLY AND UNABLE TO SUPPORT ITS INTENDED WEIGHT CAPACITY. THIS MAY LEAD TO COLLAPSE AND MAY CAUSE SERIOUS INJURY.





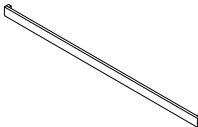
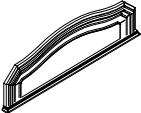
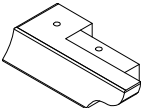

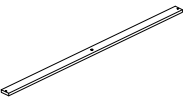
BED















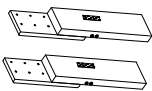
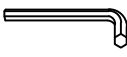
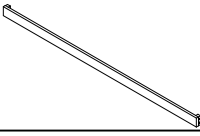
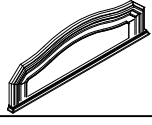

PARTS

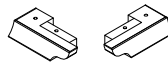
#1 1pc  Headboard	#2 2pcs  Headboard Leg(L&R)	#3 1pc  Headboard Bottom Rail	#4 1pc  Footboard
#5 2pcs  Footboard Leg(L&R)	#6 2pcs  Side rail	#7 4pcs  Slat support leg	#8 4pcs  Slat

HARDWARE

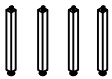
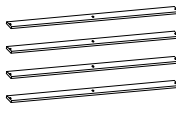
#A 16pcs  Bolt Ø1/4" x 1-3/4"	#B 20pcs  Lock Washer Ø1/4"	#C 20pcs  Flat Washer Ø1/4"
#D 3pcs  Allen Wrench M4	#E 8pcs  Screw M4 x 30mm	#F 4pcs  Bolt Ø1/4" x 2"
#G 12pcs  Bolt Ø5/16" x 1"		

packed in 3 cases

Carton	Disignation	Part	Hardware
	Headboard	#1 	 #A x 16pcs  #B x 16pcs  #C x 16pcs
	Headboard Leg(L&R)	#2 	 #D x 1pc
	Headboard Bottom Rail	#3 	
	Footboard	#4 	 #B x 4pcs  #C x 4pcs
	Footboard Leg(L&R)	#5 	 #D x 1pc  #E x 8pcs  #F x 4pcs
	Slat support leg	#7 	
	Slat	#8 	
	Side rail	#6 	 #D x 1pc  #G x 12pcs

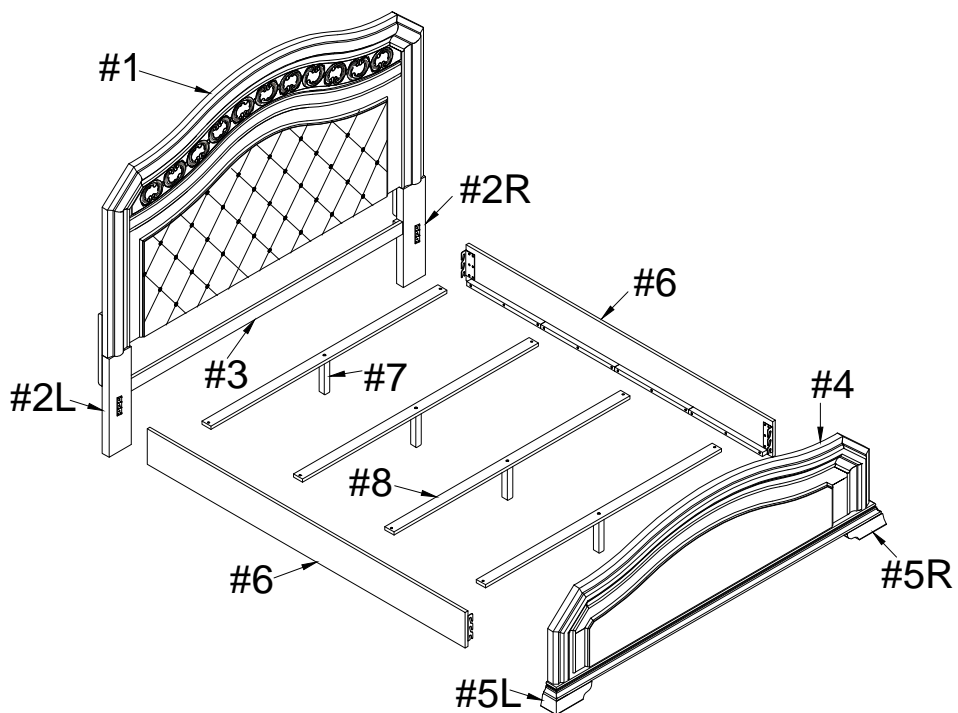

ASSEMBLY INSTRUCTIONS

1

Part #1 x1pc

Part #2 x2pcs

Hardware #A x12 pcs

Hardware #B x12 pcs

Hardware #C x12 pcs

Prepare 12 bolts assembly by inserting lock washer (#B), then flat washer (#C) onto bolts (#A). Align HB legs (#2R/L) to the holes of the headboard (#1). Secure by using bolts (#A).

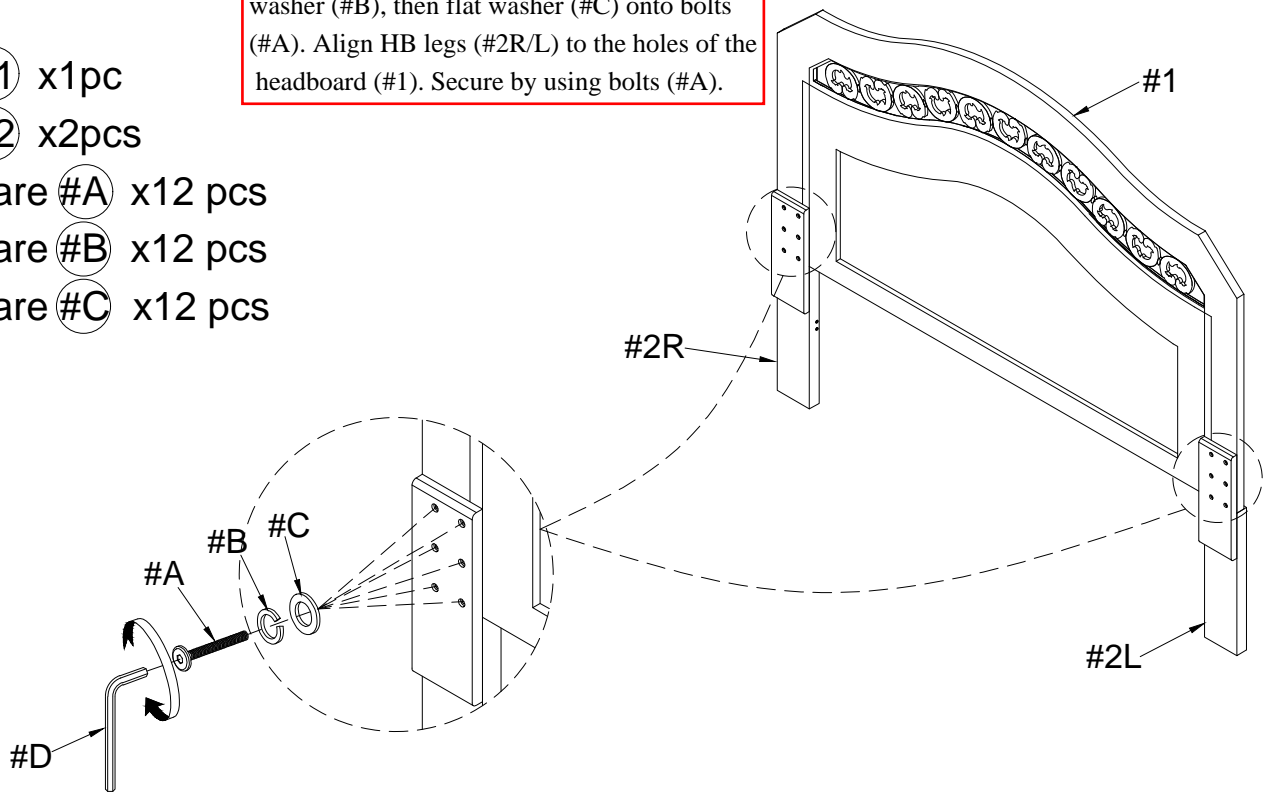

2

Part #3 x1pc

Hardware #A x4 pcs

Hardware #B x4 pcs

Hardware #C x4 pcs

Prepare 4 bolts assembly by inserting lock washer (#B), then flat washer (#C) onto bolts (#A). Align headboard bottom rail (#3) to the holes of the headboard legs (#2R/L), then secure by using bolts (#A).

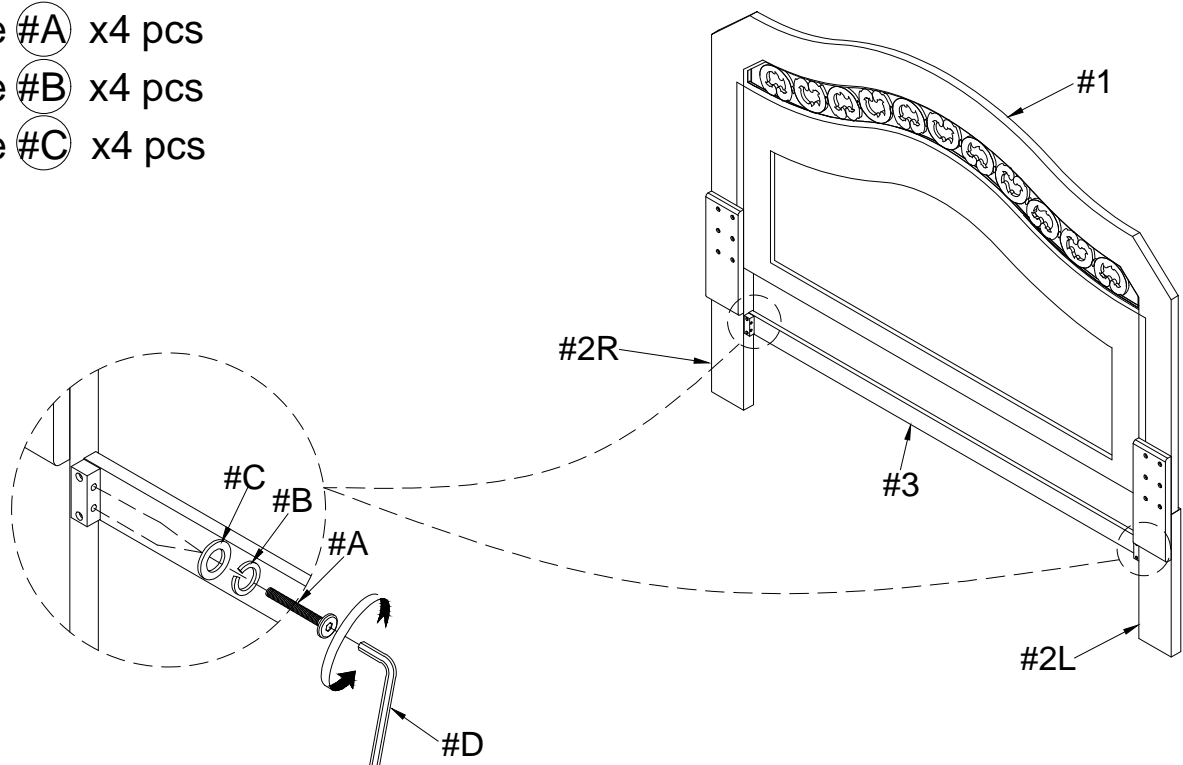

ASSEMBLY INSTRUCTIONS

3

Part #4 x1pc

Part #5 x2pcs

Hardware #B x4 pcs

Hardware #C x4 pcs

Hardware #F x4 pcs

Prepare 4 bolts assembly by inserting lock washer (#B), then flat washer (#C) onto bolts (#F).
Align footboard legs (#5R/L) to the holes of the footboard (#4). Secure by using bolts (#F).

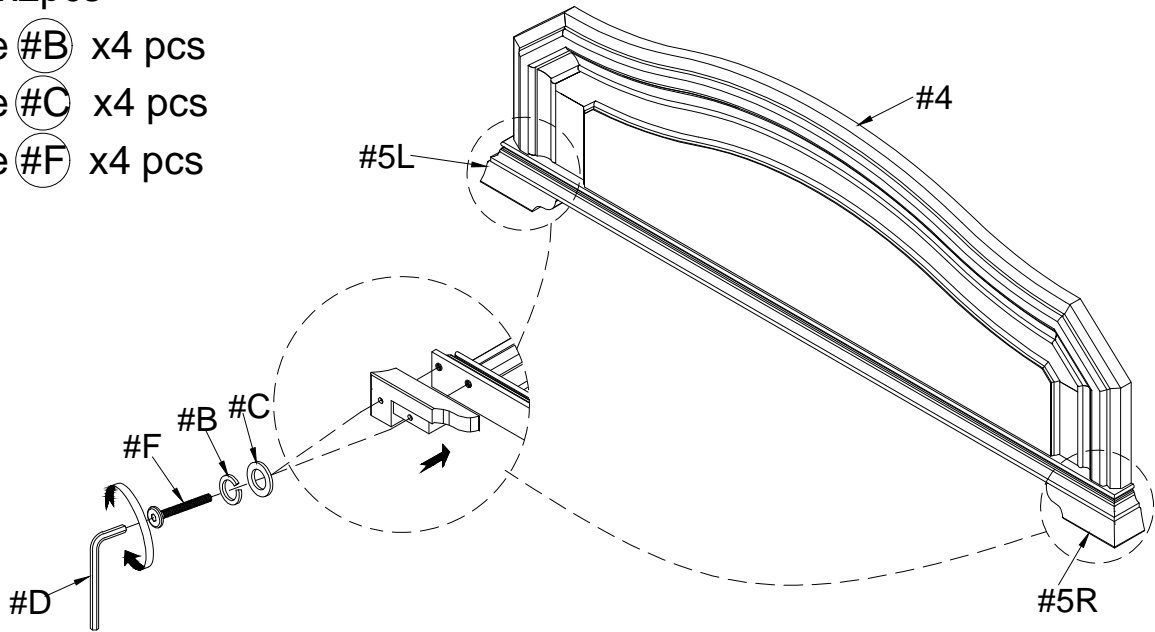

4

Part #6 x2pcs

Hardware #G x12 pcs

Attach bolts (#G) half way into the holes of the headboard (#1) and footboard (#2).
Align and hook side rails (#6) to the bolts (#G). Secure by tightening bolts (#G).

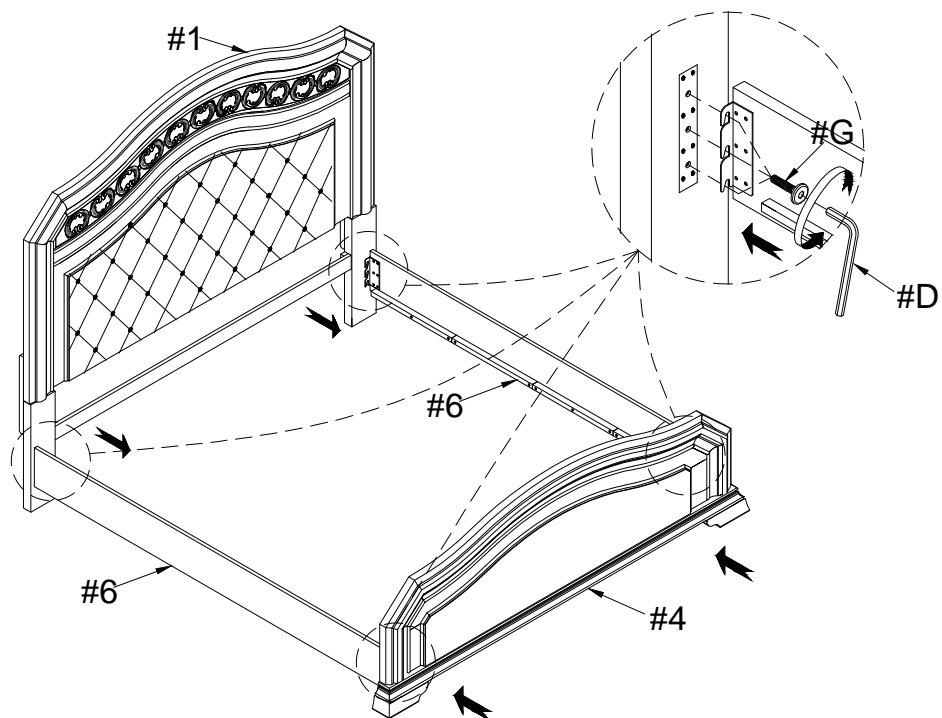

ASSEMBLY INSTRUCTIONS

5

Part #7 x4pcs

Part #8 x4pcs

Attach support legs (#7) to the holes of the slats (#8), then adjust the leveler on the support legs (#7) according to ground level.

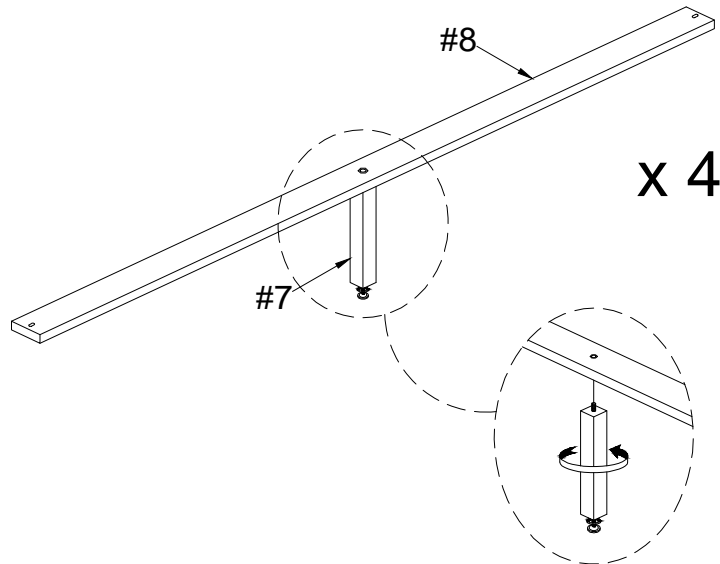

6

Hardware #E x8 pcs

Align slats to the side rails, secure by using screws (#E).

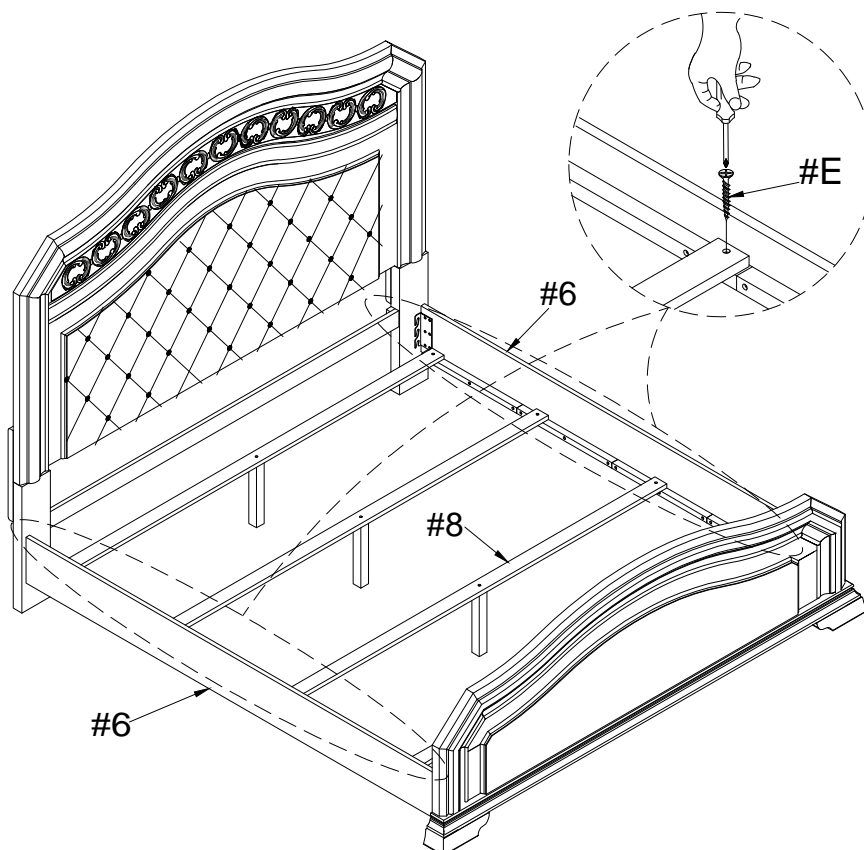

ASSEMBLY COMPLETED



Please ensure the furniture rests on an even and flat surface. If the product wobbles or feels loose, double-check all bolts and/or screws are properly tightened and secured.



Keep this handy!

Please retain this instruction manual and any order-related information for future reference.



Lift, don't drag!

To avoid damage to product please always LIFT the product when transporting or adjusting the placement.