

# Assembly Guide



If you're having any difficulty during assembly of this product, don't hesitate to call us

Our customer service experts are trained to provide step-by-step instruction and can easily replace any missing or damaged parts.

**Representatives are available Monday-Friday  
from 8:30 a.m. to 7:30 p.m. (ET)**

## 60W Tall TV Stand

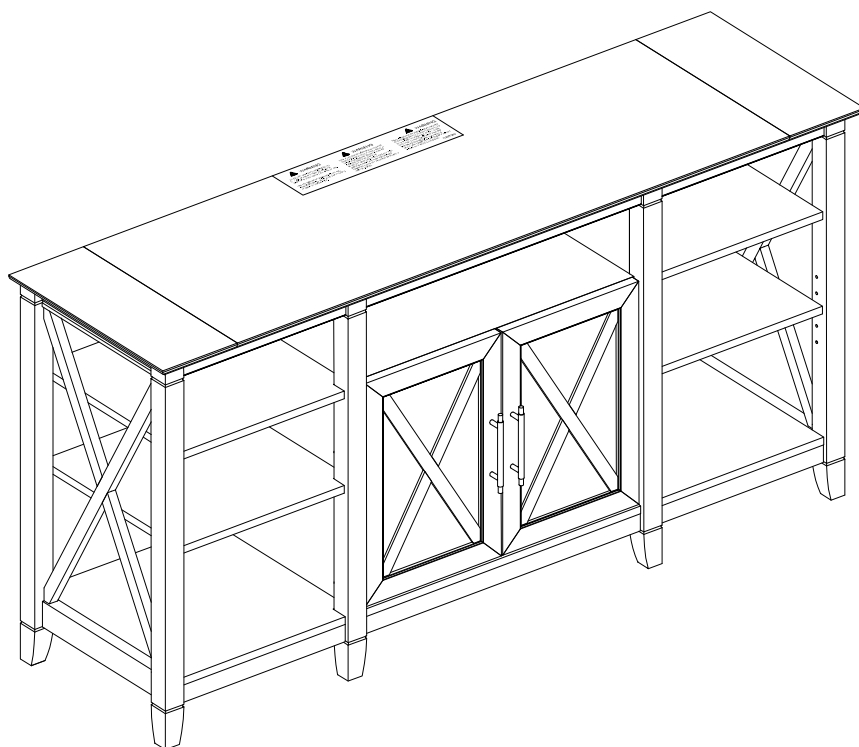

# Get Ready to Assemble

## For best results, keep these tips in mind:

- ① We know you want to finish this assembly as quickly as possible, but trust us: you'll have a better experience if you take it one step at a time.
- ② Give yourself some room to work near where you want the fully assembled product.
- ③ If your floor isn't carpeted, assemble this product on the empty carton to avoid scratching.
- ④ Do you have a friend who owes you a favor? Some steps may go a little easier with a second set of hands.

### DOs

- ✔ Use a #2 Phillips head screwdriver (or other handheld tools as indicated)
- ✔ Wear safety glasses at all times during assembly
- ✔ Carefully follow the instructions in this guide and complete all steps in order
- ✔ Give us a call if you're having trouble with a particularly tricky step

### DON'Ts

- ✘ We know power tools are quick and easy, but you shouldn't use them when assembling this product (unless otherwise specified)
- ✘ Never move your furniture with items inside or resting on the surface
- ✘ Do not attempt to use this product before all steps have been completed

## Watch assembly videos right on your phone or computer!

Some steps include QR codes that link to helpful videos. Watch out for the icon on the left! Simply open up your smartphone camera to scan the code.

*(Users of older smartphones may need to install a QR Reader.)*



# IMPORTANT SAFETY INFORMATION



## PLEASE READ WARNINGS

Improper use can cause safety hazards, or damage to your furniture and household items.

| Warning                                   | Do   | Don't  | Why it's important   |
|---|--|--|--|
| <b>Serious injury or death may occur.</b> | <ul style="list-style-type: none"><li>• Only place flat screen TVs on this product</li><li>• Assemble following all instructions using all indicated parts and hardware provided.</li><li>• For use with televisions weighing 60 pounds (27.2 kg) or less and having a diagonal screen size of 65 inches (1651 mm) or less</li><li>• Install every indicated nail and/or screw.</li><li>• Verify Furniture is stable on it's own.</li><li>• Place heaviest items in the lower drawers or shelves.</li><li>• Always install tipover restraint hardware provided.</li><li>• Remove items that might tempt kids to climb, such as toys and remote controls from the top and upper shelves of furniture.</li></ul> | <ul style="list-style-type: none"><li>• Do not move unit when loaded.</li><li>• Do not exceed the maximum load limits stated in the instructions.</li><li>• Do not allow children to stand, climb, or hand on furniture.</li></ul> | Improper assembly, use or loading can lead to product instability, tip-over or collapse. |

## IMPORTANT SAFETY INFORMATION



# PLEASE READ WARNINGS

Improper use can cause safety hazards, or damage to your furniture and household items.

| Advertencia  | Hacer   | No  | Por qué es importante  |
|--|---|---|--|
| <b>Se pueden producir lesiones graves o la muerte.</b> | <ul style="list-style-type: none"><li>• Solo coloque televisores de pantalla plana en este producto.</li><li>• Ensamble siguiendo todas las instrucciones utilizando todas las piezas y hardware indicados provistos.</li><li>• Para usar con televisores con un peso de 60 libras (27.2 kg) o menos y tener una diagonal tamaño de pantalla de 65 pulgadas (1651 mm) o menos</li><li>• Instale cada clavo y / o tornillo indicado.</li><li>• Verifique que los muebles sean estables por sí mismos.</li><li>• Coloque los artículos más pesados en los cajones o estantes inferiores.</li><li>• Siempre instale el hardware de restricción tipover proporcionado.</li><li>• Retire los artículos que puedan tentar a los niños a trepar, como juguetes y controles remotos de los estantes superiores y superiores de los muebles.</li></ul> | <ul style="list-style-type: none"><li>• No mueva la unidad cuando esté cargada.</li><li>• No exceda los límites máximos de carga establecidos en las instrucciones.</li><li>• No permita que los niños se paren, trepen o toquen los muebles.</li></ul> | El ensamblaje, uso o carga inadecuados pueden provocar inestabilidad del producto, vuelco o colapso. |

## IMPORTANT SAFETY INFORMATION



# PLEASE READ WARNINGS

Improper use can cause safety hazards, or damage to your furniture and household items.

| Avertissement  | Faire  | Ne le fais pas   | Pourquoi c'est important   |
|--|--|--|--|
| <b>Des blessures graves ou la mort peuvent survenir.</b> | <ul style="list-style-type: none"><li>Placez uniquement des téléviseurs à écran plat sur ce produit.</li><li>Assemblez en suivant toutes les instructions en utilisant toutes les pièces et le matériel indiqués fournis.</li><li>Pour une utilisation avec les téléviseurs pesant 60 livres (27.2 kg) ou moins et ayant une diagonale écran de 65 pouces (1651 mm) ou moins</li><li>Installez tous les clous et / ou vis indiqués.</li><li>Vérifiez que les meubles sont stables par eux-mêmes.</li><li>Placez les articles les plus lourds dans les tiroirs ou les étagères inférieurs.</li><li>Installez toujours le matériel de retenue de renversement fourni.</li><li>Retirez les éléments qui pourraient inciter les enfants à grimper, tels que les jouets et les télécommandes des étagères supérieure et supérieure des meubles.</li></ul> | <ul style="list-style-type: none"><li>Ne déplacez pas l'unité lorsqu'elle est chargée.</li><li>Ne dépassez pas les limites de charge maximales indiquées dans les instructions.</li><li>Ne laissez pas les enfants se tenir debout, grimper ou mettre la main sur des meubles.</li></ul> | Un assemblage, une utilisation ou un chargement incorrects peuvent entraîner une instabilité du produit, un renversement ou un effondrement. |

# Get to know your Boards

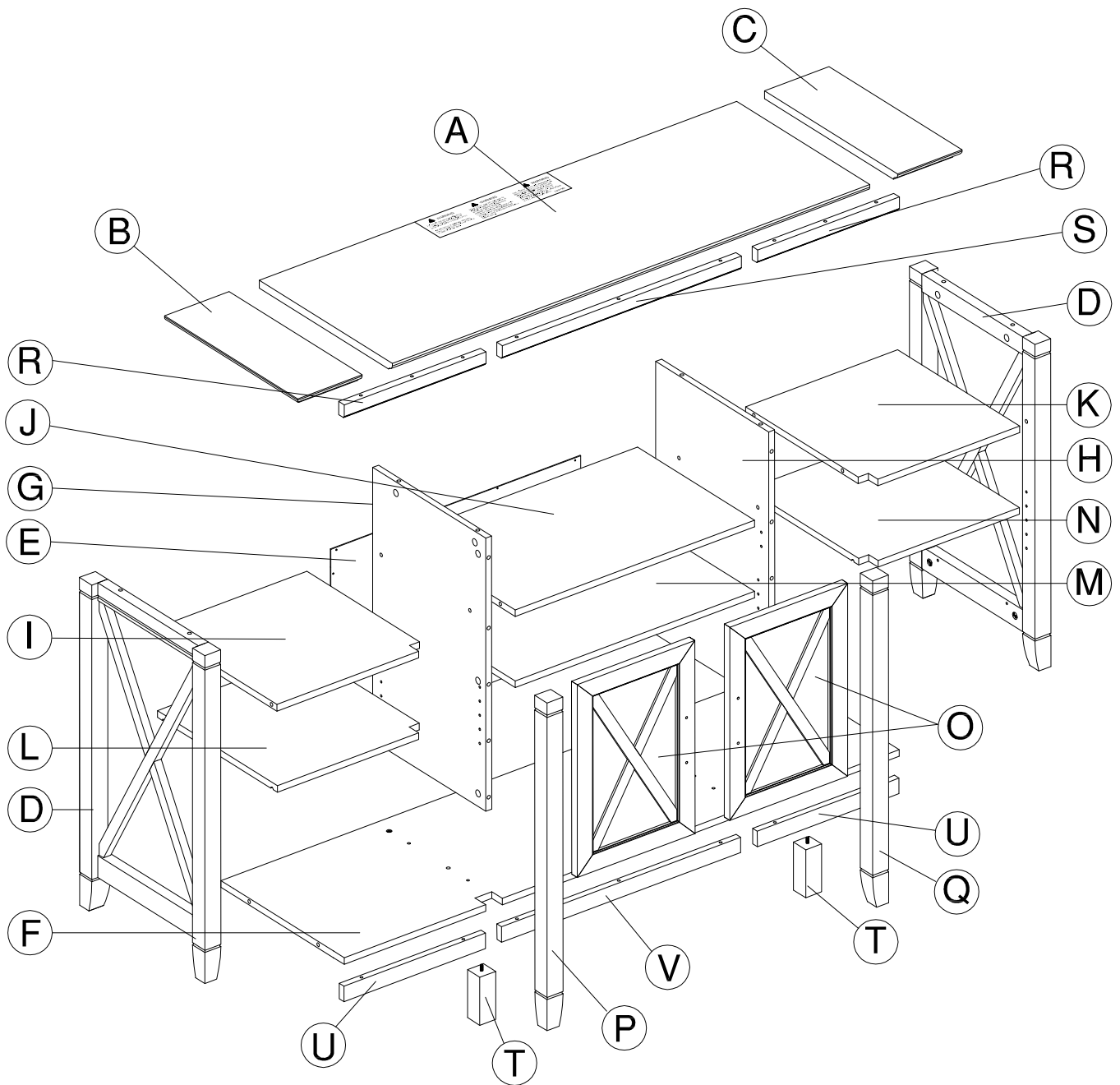
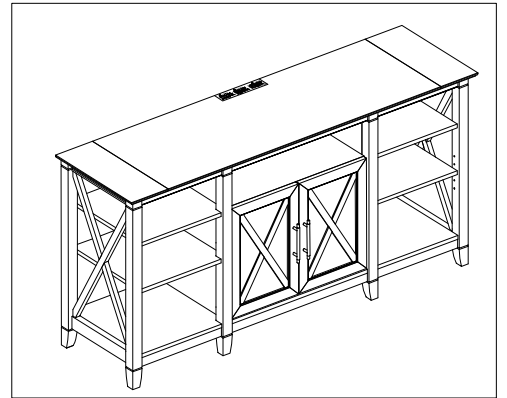

# Get to know your Fasteners

Fasteners are shown actual size.

H181468

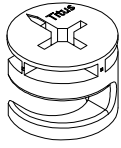

KD Cam

[ 30 ]

H180604

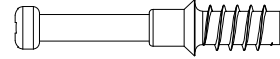

KD Bolt

[ 10 ]

H38169

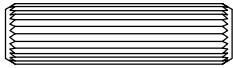

Wood Dowel  
8 x 30mm

[ 6 ]

H166336

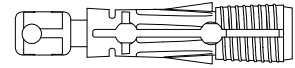

Quick Connect

[ 20 ]

H158933



#8 x 3/4"

[ 4 ]

H34174



#3 x 3/4"

[ 16 ]

H153242

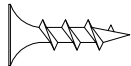

#8 x 5/8"

[ 8 ]

H35251

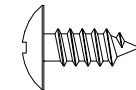

#10 x 1/2"

[ 16 ]

H23491

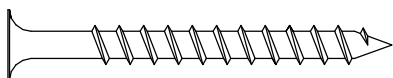

#10 x 2"

[ 4 ]

H23370

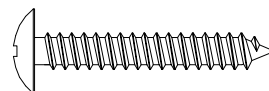

#10 x 1-1/4"

[ 16 ]

# Get to know your Hardware

Hardware not to scale.

H170611

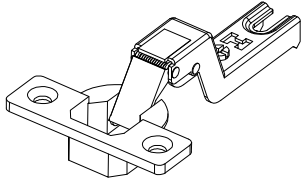

[ 4 ]

Hinge Arm

H170612

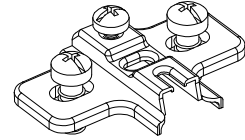

[ 4 ]

Mounting Plate

H23604

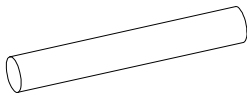

[ 12 ]

Shelf Pin

H126396

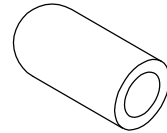

[ 4 ]

Shelf Pin Sleeve

H39922

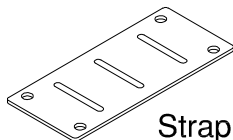

[ 4 ]

Strap

H77351

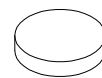

[ 2 ]

Bumper  
Ø10x2mm

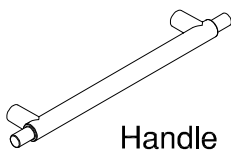

[ 2 ]

Handle



[ 10 ]

Cover Cap

# Get to know your Hardware

Hardware not to scale.

## TIP OVER RESTRAINT HARDWARE

### Q203419

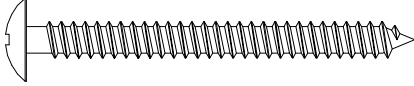
H181434  [ 1 ]  
#10 x 2"

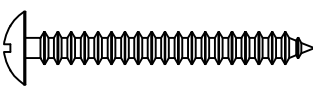
H107572  [ 1 ]  
#8 x 1-1/2"

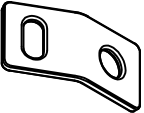
H181412  [ 2 ]  
Connecting Plate

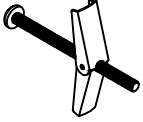
H181419  [ 1 ]  
Toggle Bolt

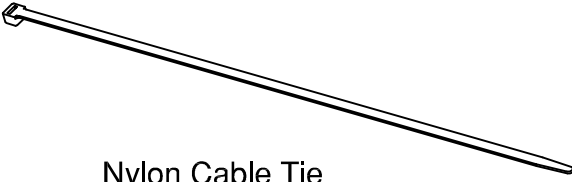
H181411  [ 1 ]  
Nylon Cable Tie

# STEP 1

# Prepare Doors

H153242



[ 8 ]

#8 x 5/8"

H170611

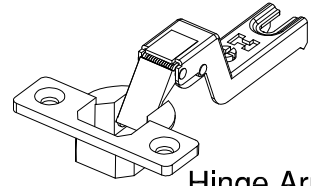

[ 4 ]

Hinge Arm

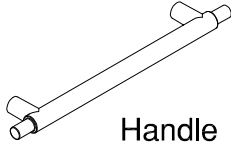

[ 2 ]

Handle

H158933



[ 4 ]

#8 x 3/4"

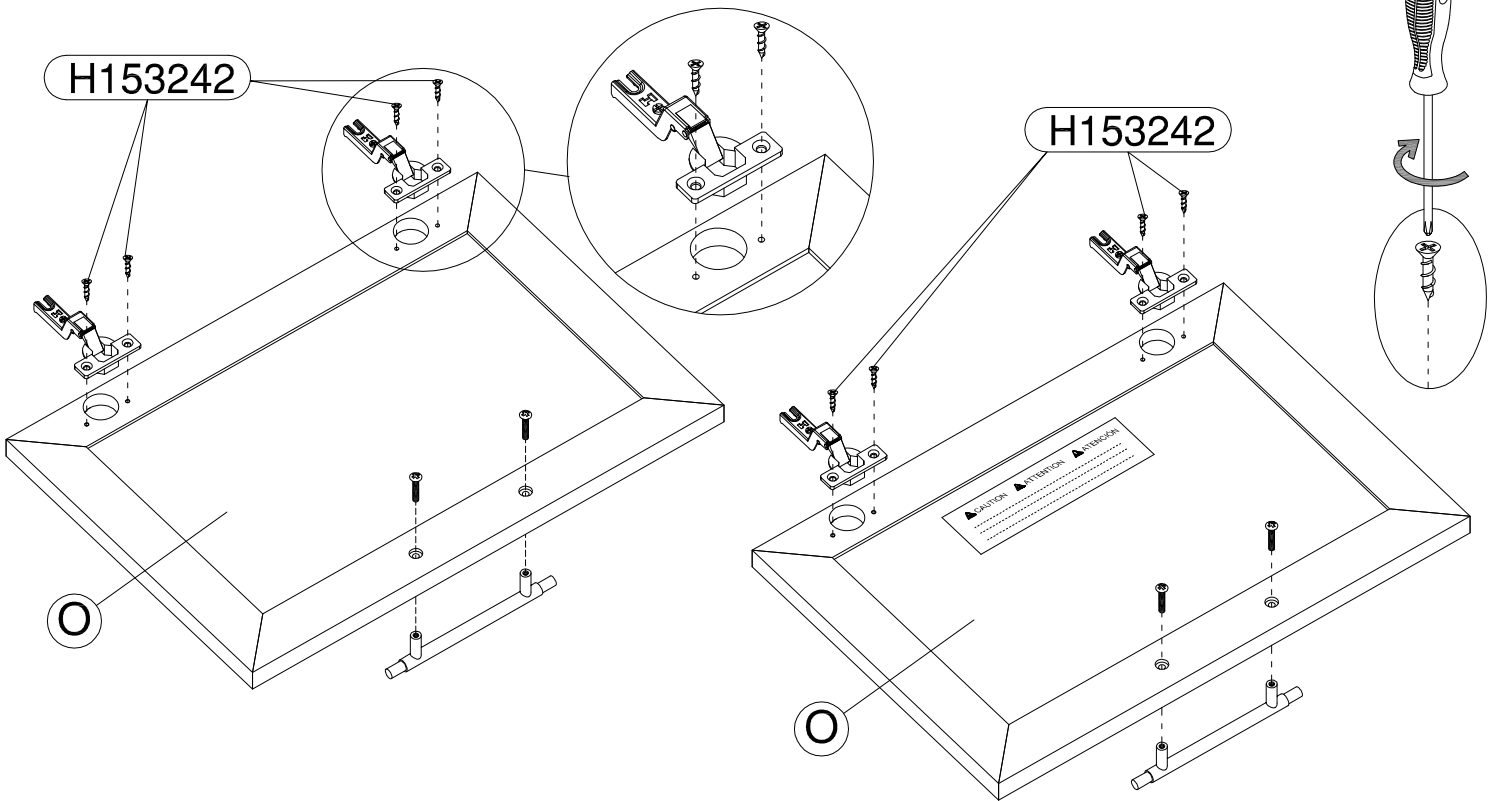

CAUTION



ATTENTION



ATENCIÓN

Electronic equipment may overheat causing damage. Do Not store electronic equipment behind doors.

El equipo electrónico puede sobrecalentarse y causar daños. No almacene equipos electrónicos detrás de las puertas.

L'équipement électronique peut surchauffer et causer des dommages. Ne stockez pas d'équipement électronique derrière des portes.

# STEP 2

# Prepare Panels

H166336

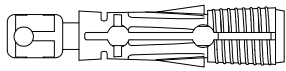

[ 4 ]

Quick Connect

H38169



[ 6 ]

Wood Dowel  
8 x 30mm

H170612

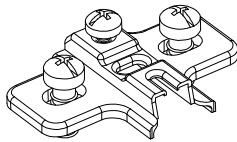

[ 4 ]

Mounting Plate

The KD Cam holes on part must face down.  
Los orificios KD Cam en parte deben mirar hacia abajo.  
Les trous de la KD Cam sur la pièce doivent être orientés vers le bas.

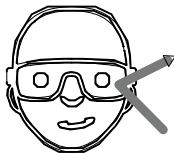

Safety glasses  
Gafas de seguridad  
Lunettes de protection

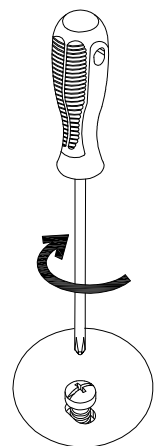
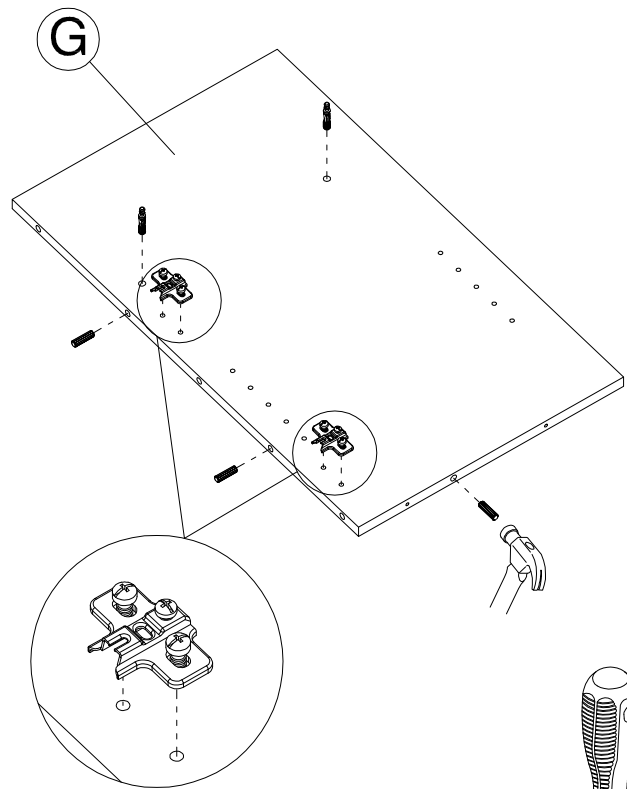
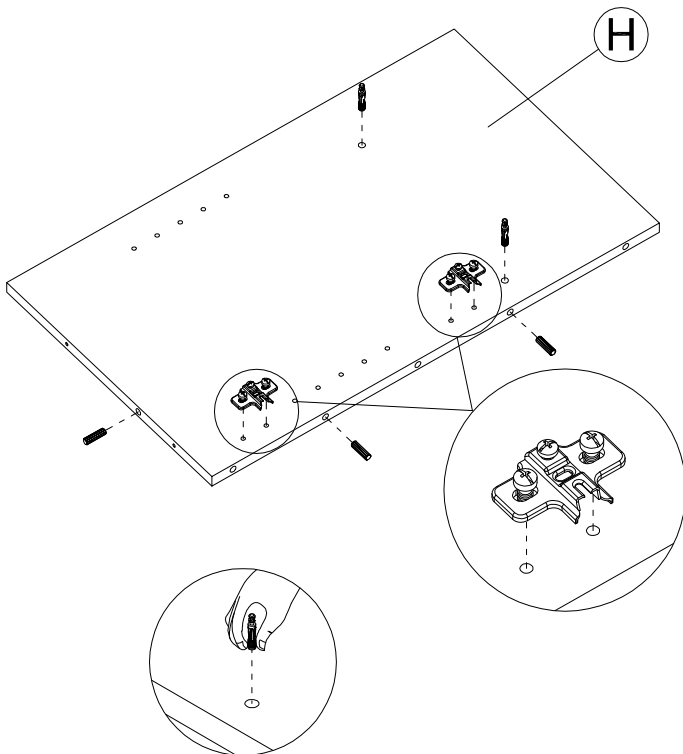

# STEP 3

# Assemble Panels

H181468

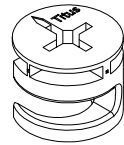

KD Cam

[ 2 ]

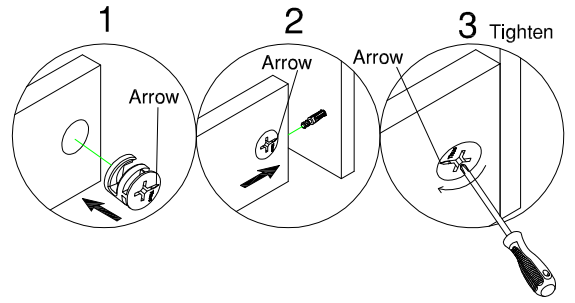

Finished edge  
Borde terminado  
Cote fini

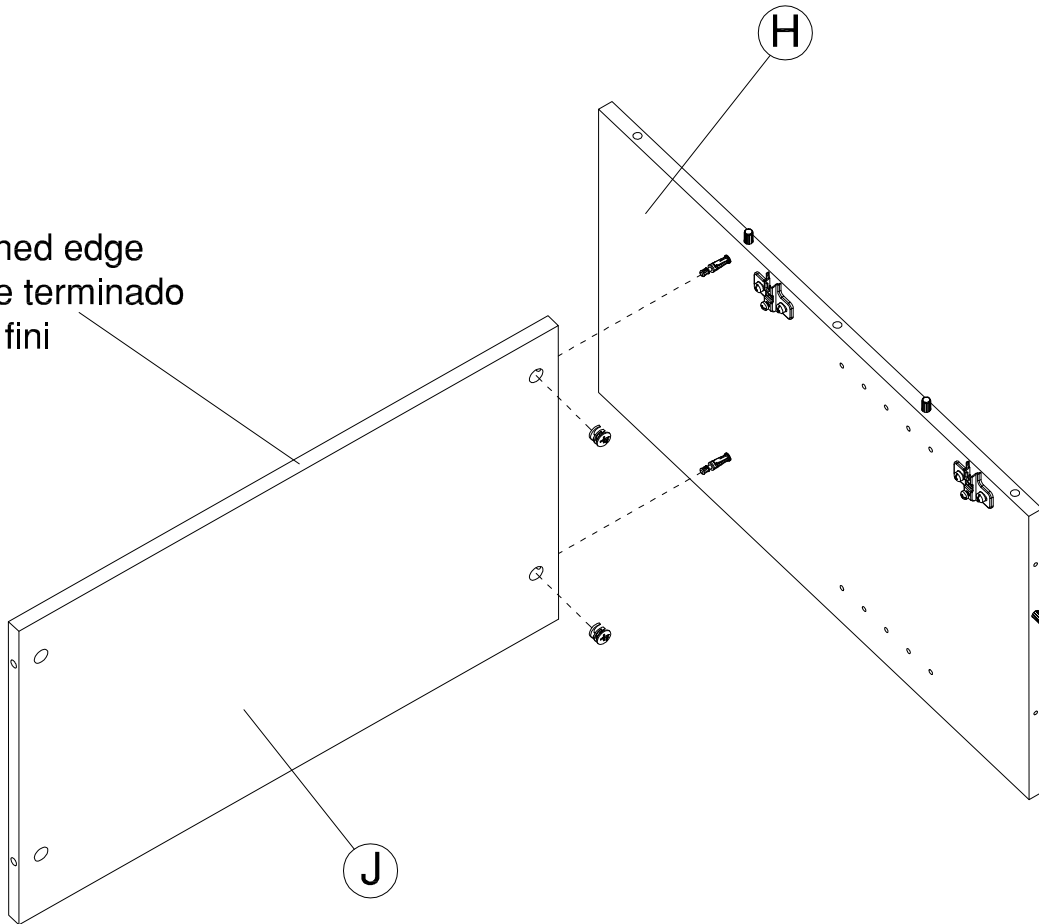

# STEP 4

# Assemble Panels

H181468

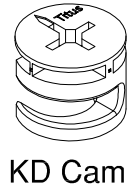

[ 2 ]

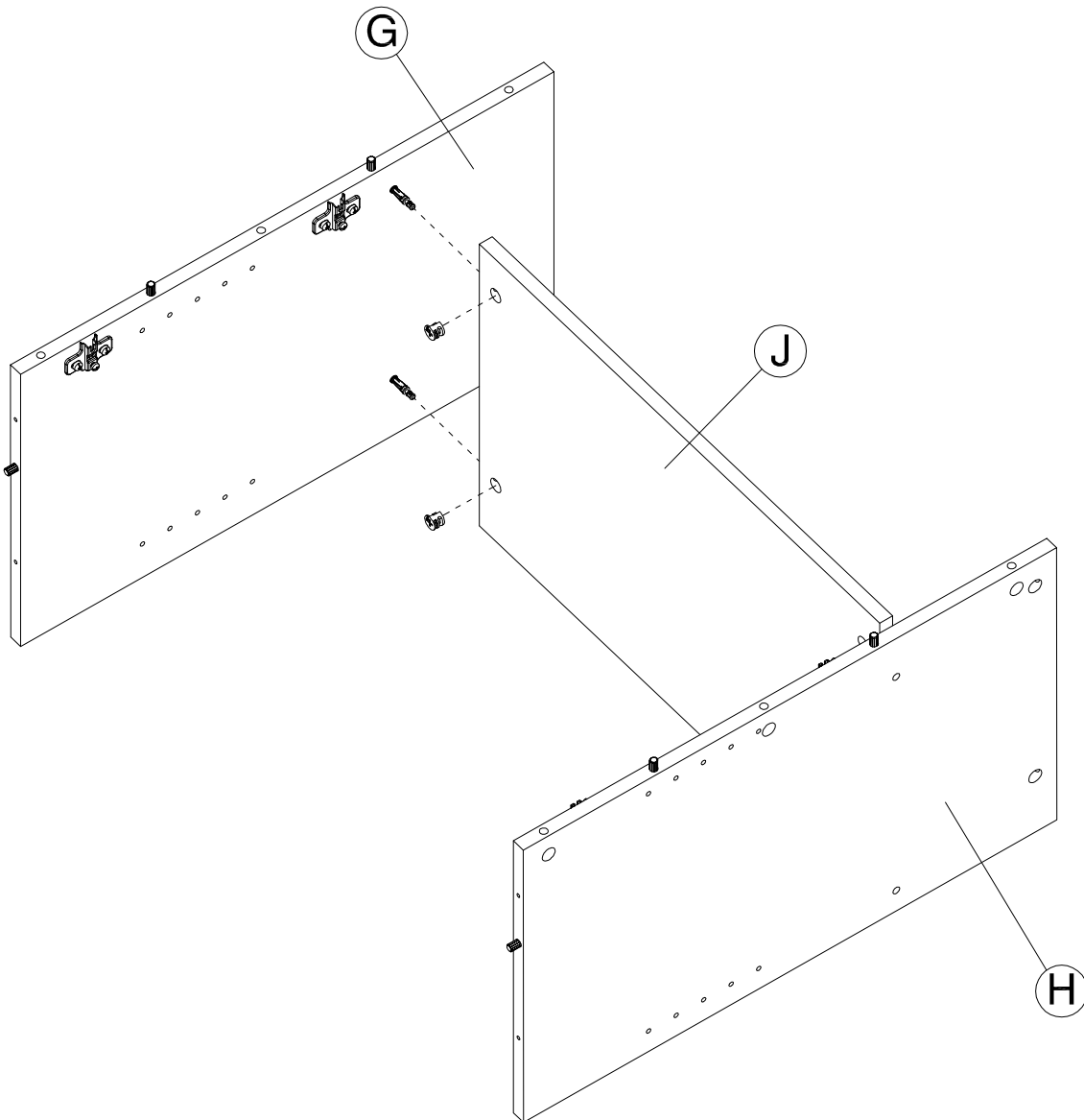
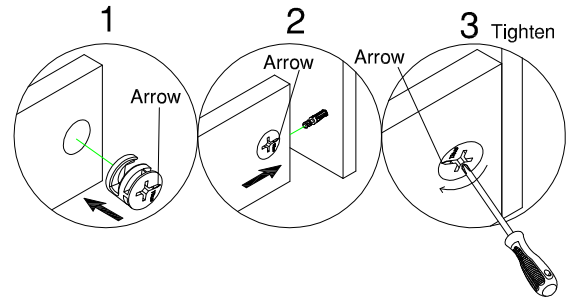

# STEP 5

# Assemble Panels

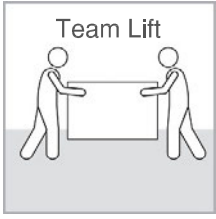

H23491

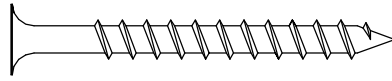

[ 4 ]

#10 x 2"

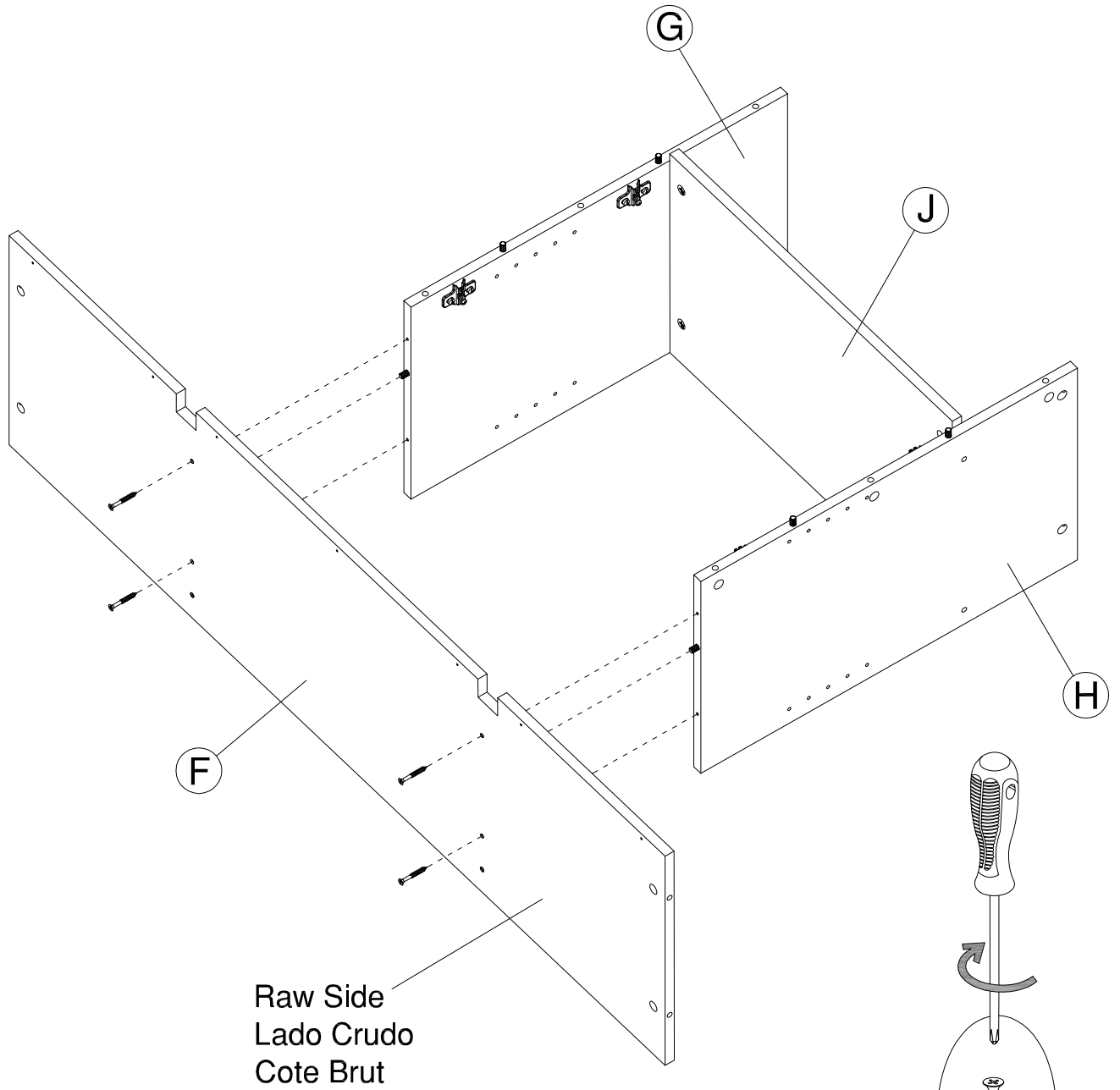

# STEP 6

# Prepare Panels

H180604

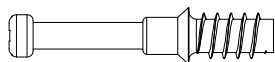

[ 6 ]

KD Bolt

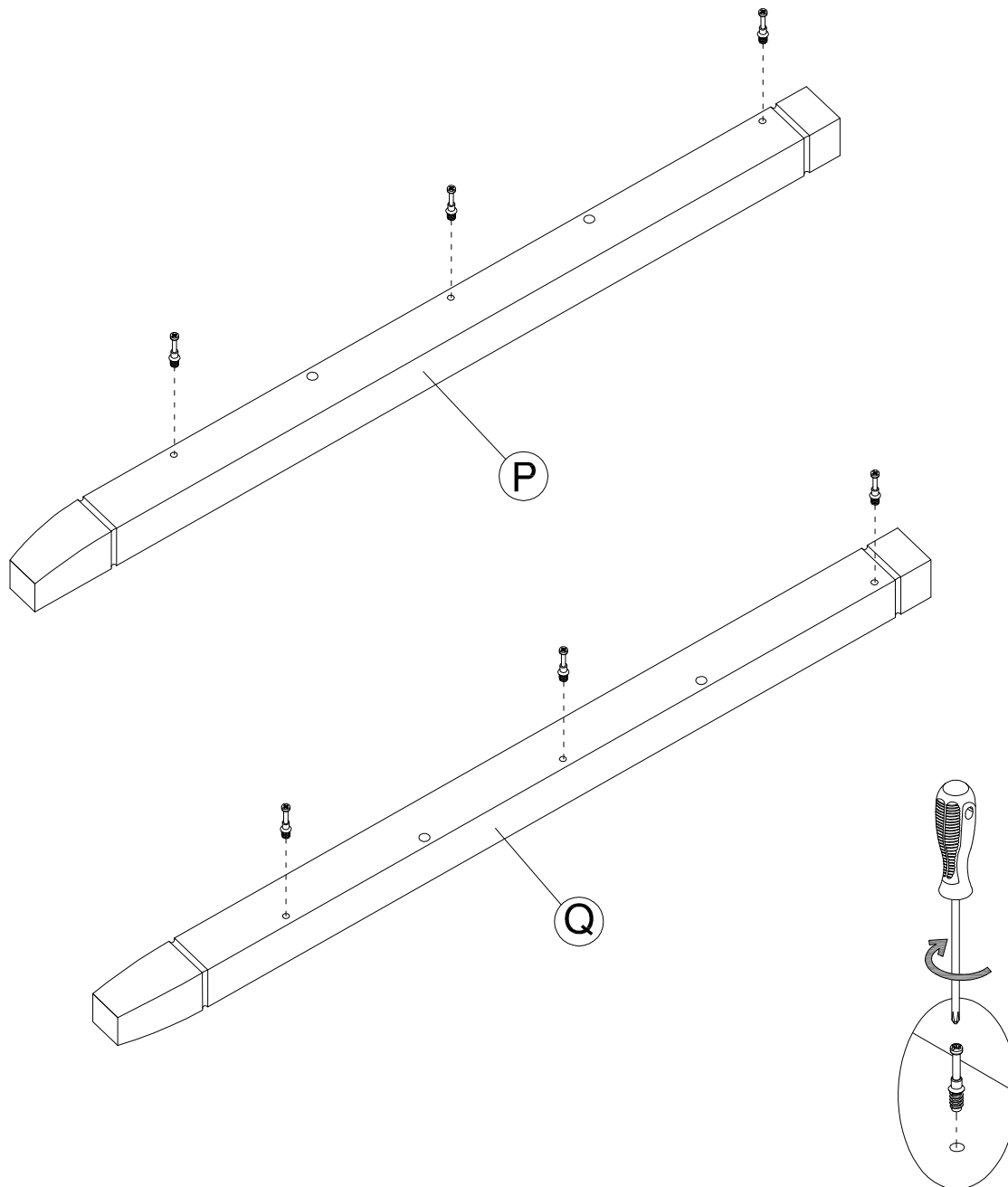

# STEP 7

# Assemble Panels

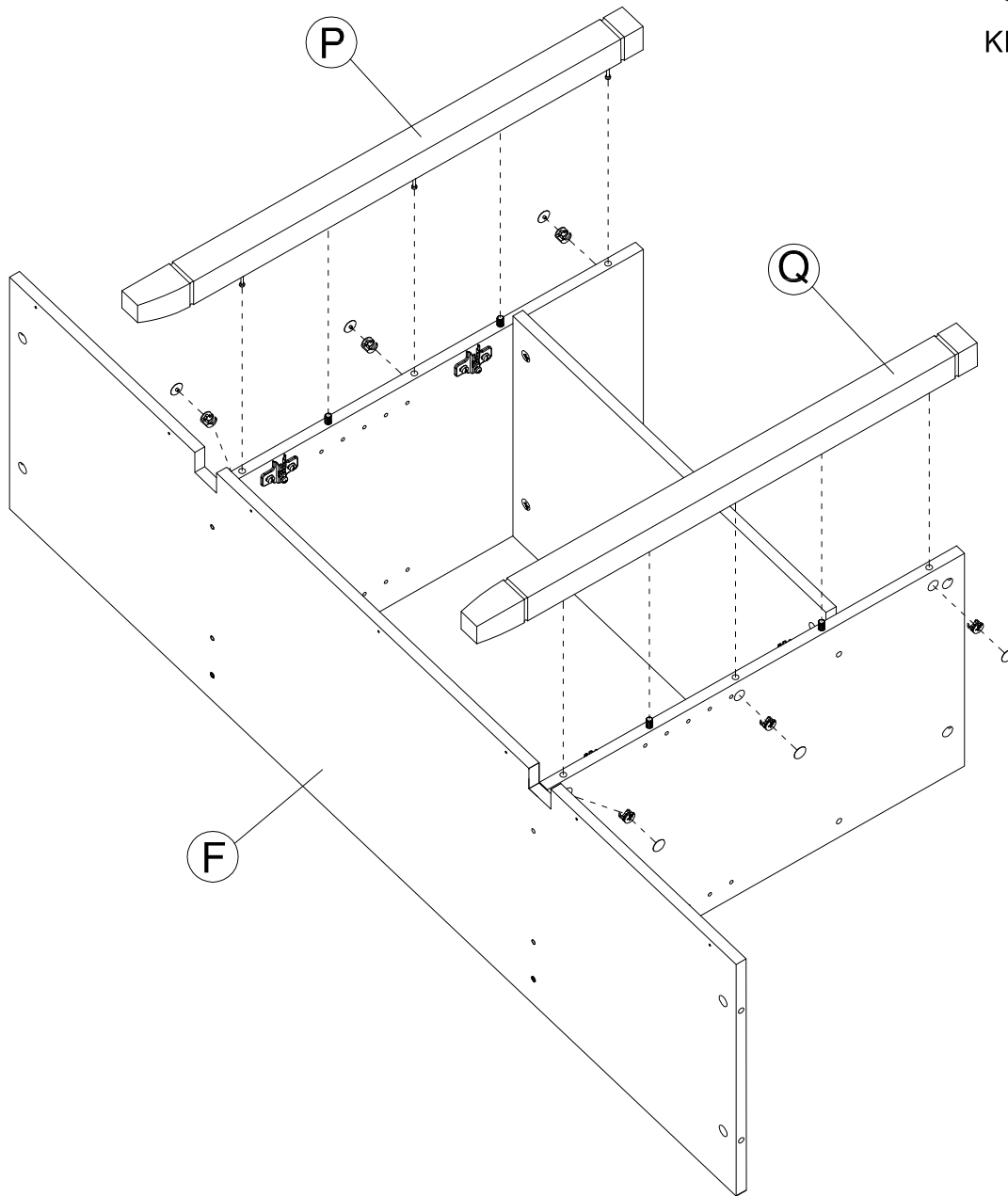
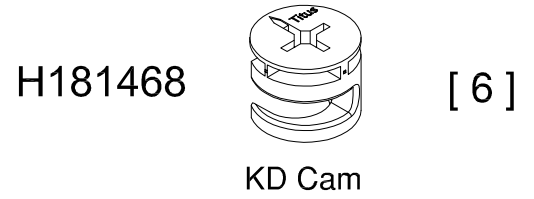
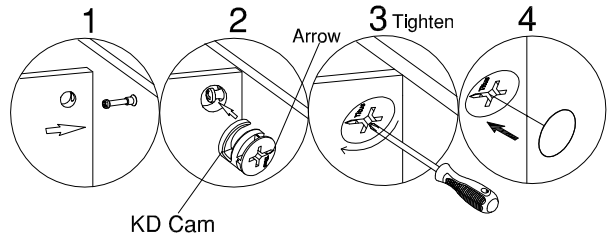
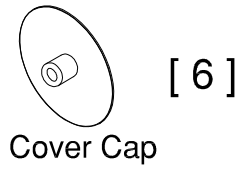

# STEP 8

# Install Feet

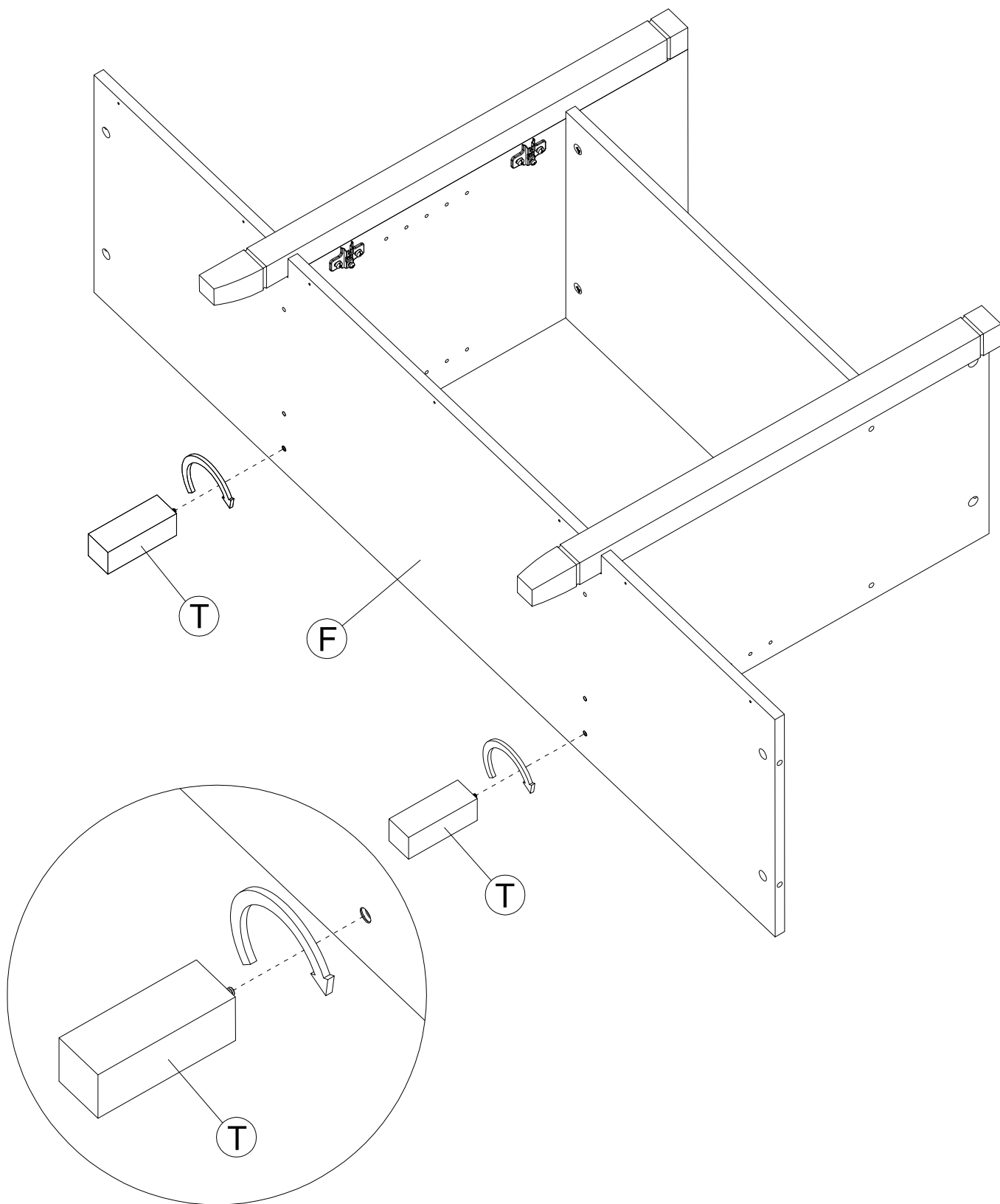

# STEP 9

# Install Fasteners

H180604

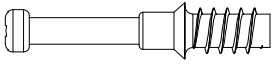

KD Bolt

[ 4 ]

H166336

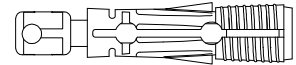

Quick Connect

[ 4 ]

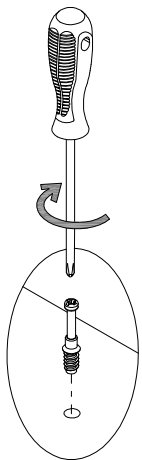
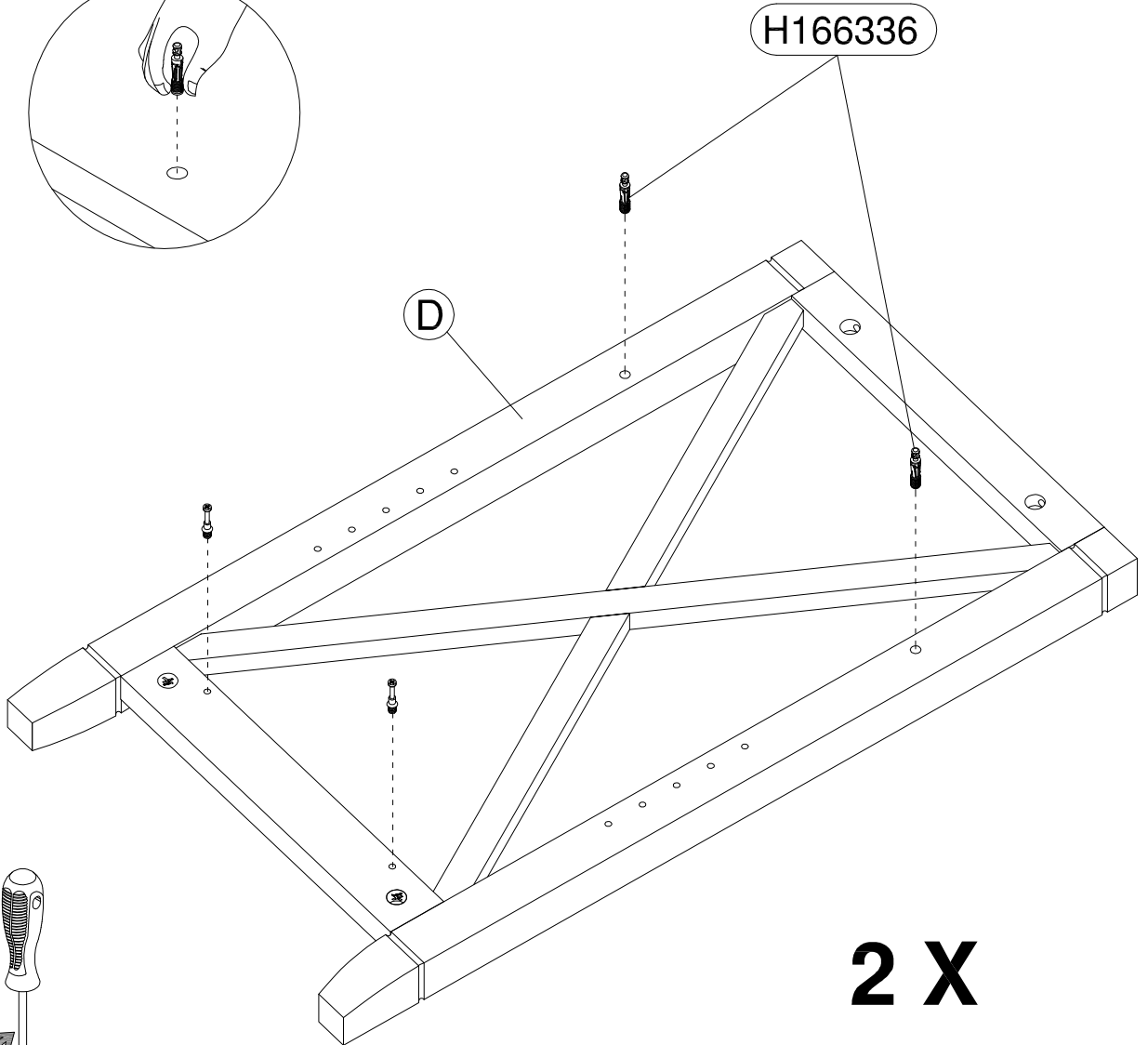
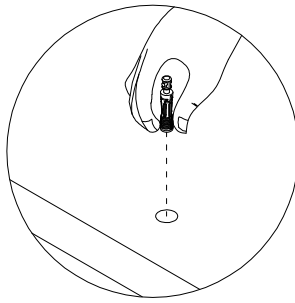

**2 X**

# STEP 10

# Insert Fasteners

H166336

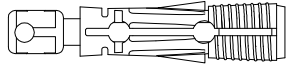

[ 2 ]

Quick Connect

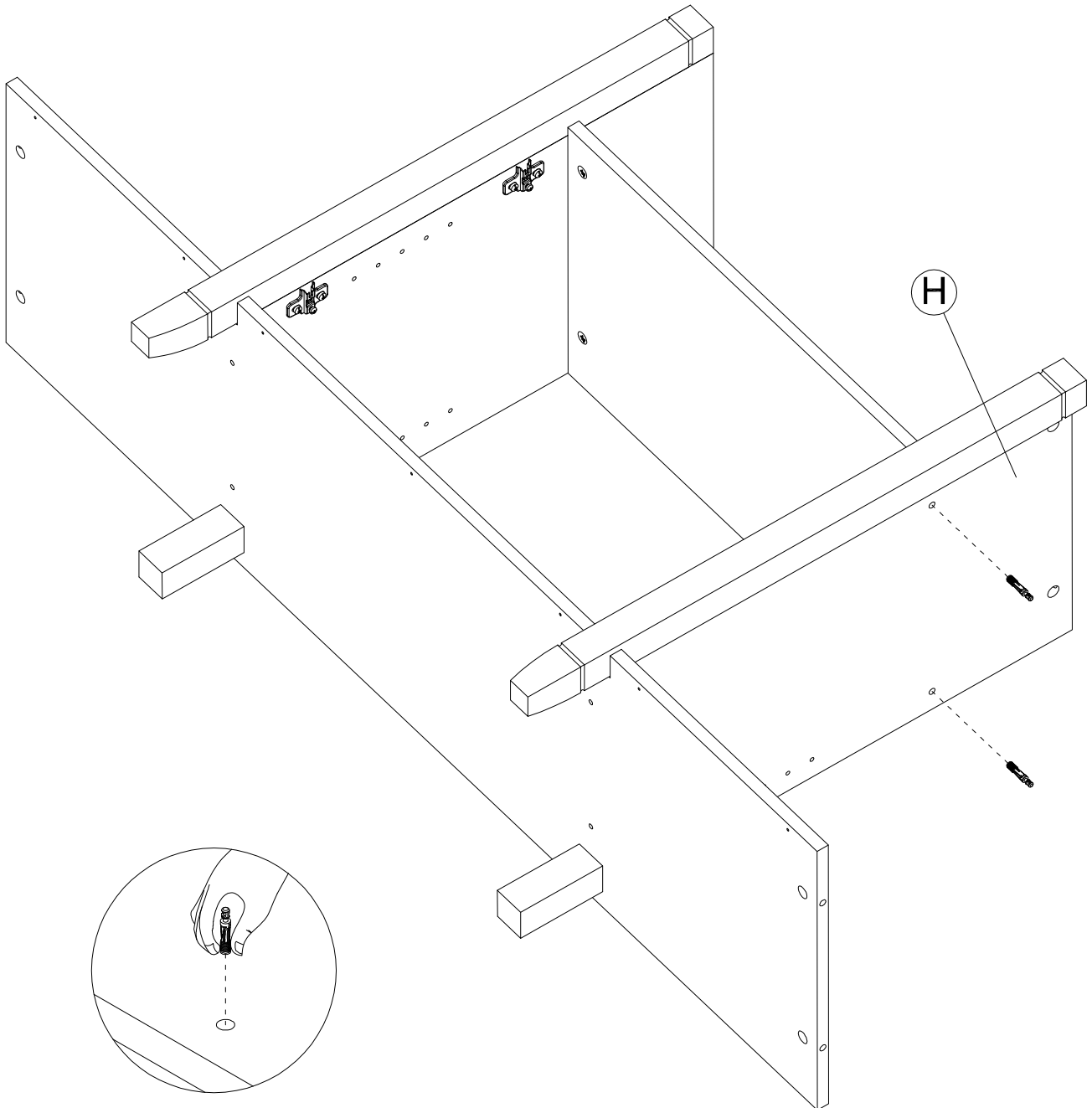

# STEP 11

# Assemble Panel

H181468

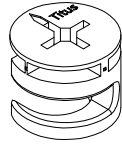

KD Cam

[ 2 ]

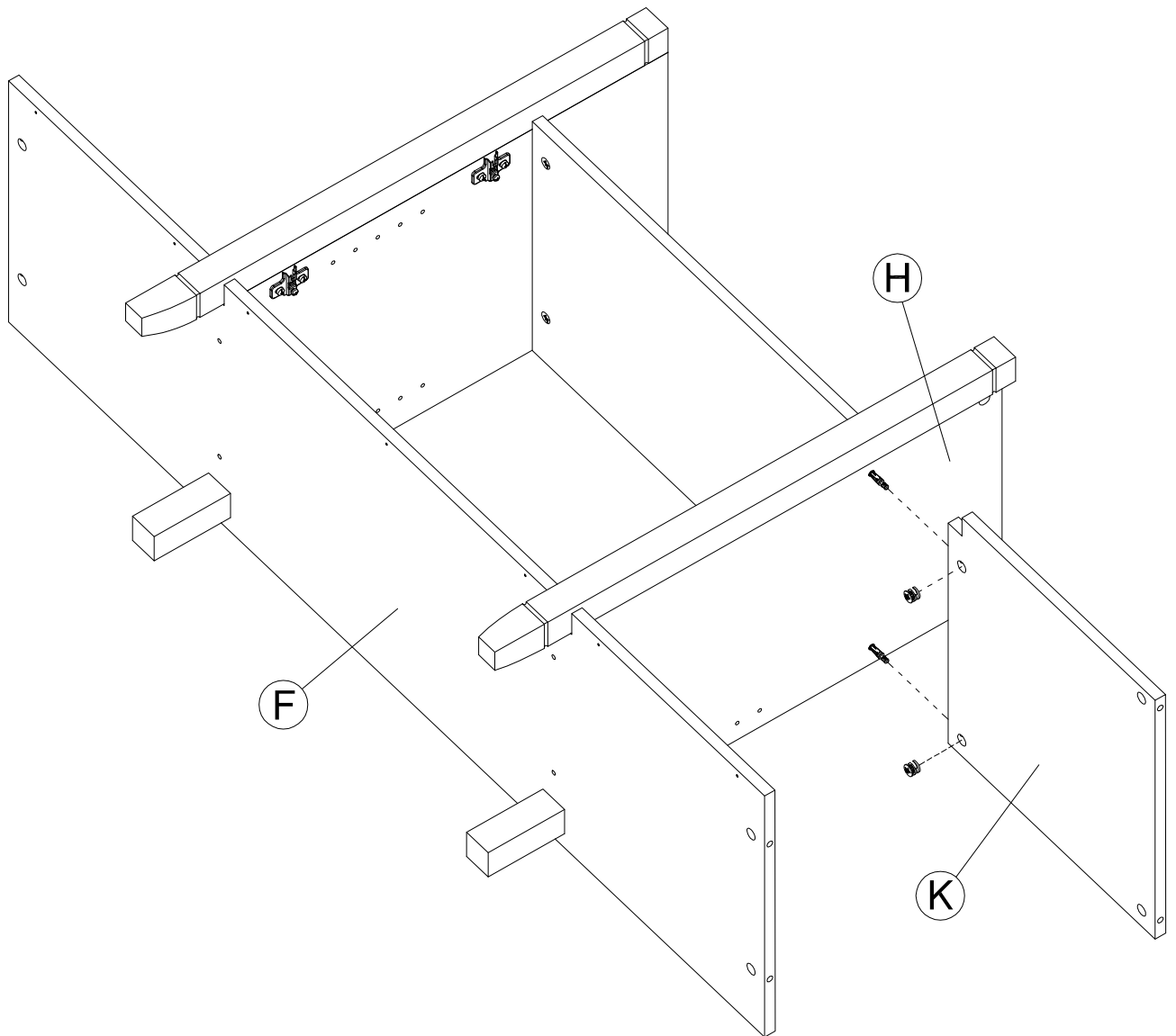
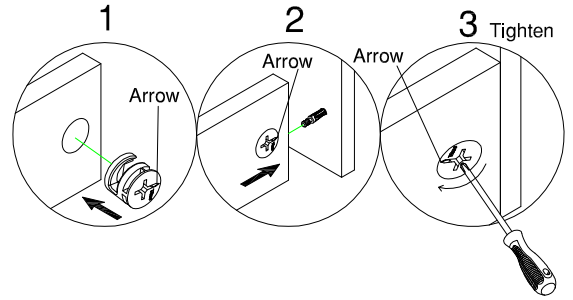

# STEP 12

# Assemble Panels

Scan QR Code to Watch Video on:



How to Tighten KD Cams

H181468

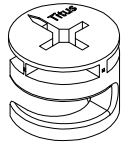

KD Cam

[ 4 ]

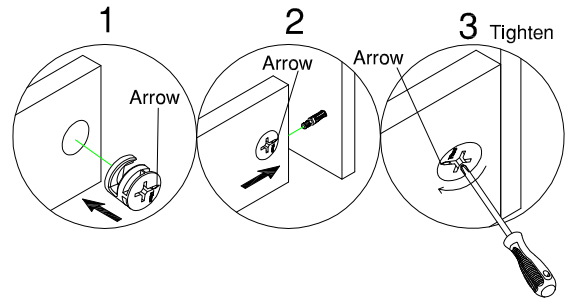

Team Lift

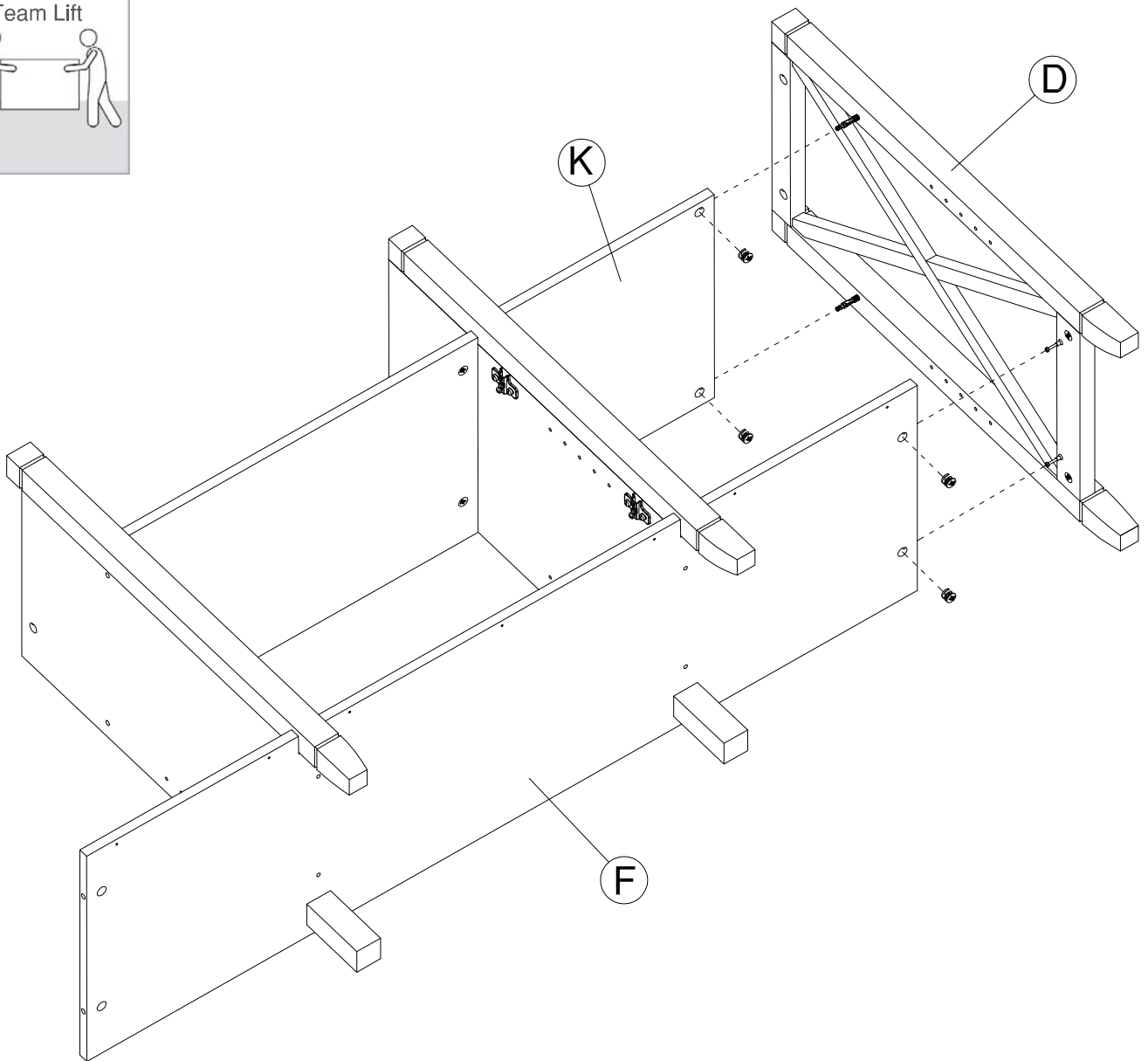

# STEP 13

# Insert Fasteners

H166336

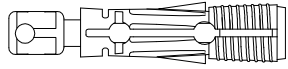

[ 2 ]

Quick Connect

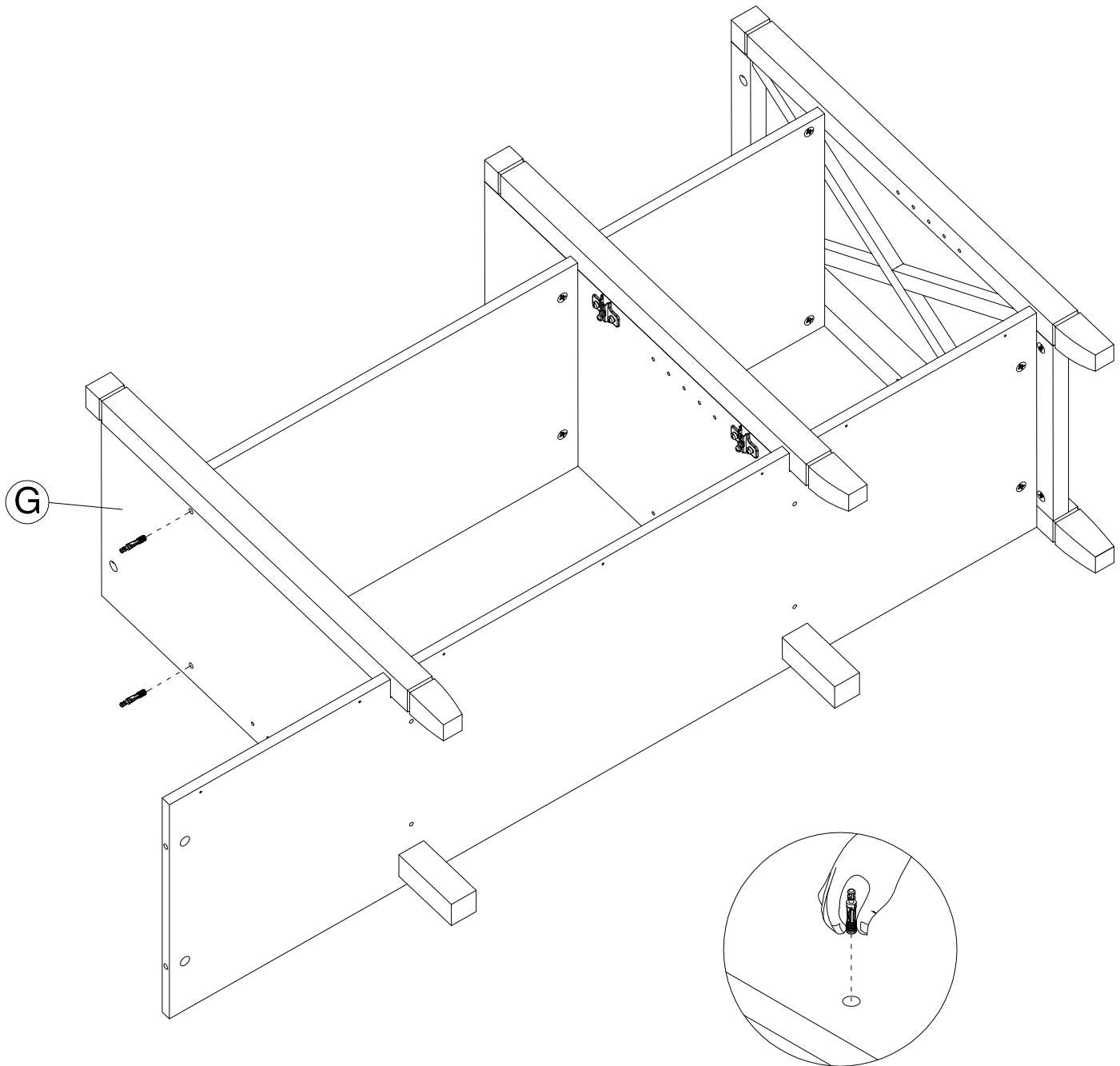

# STEP 14

# Assemble Panel

H181468

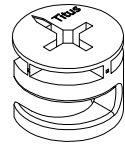

KD Cam

[ 2 ]

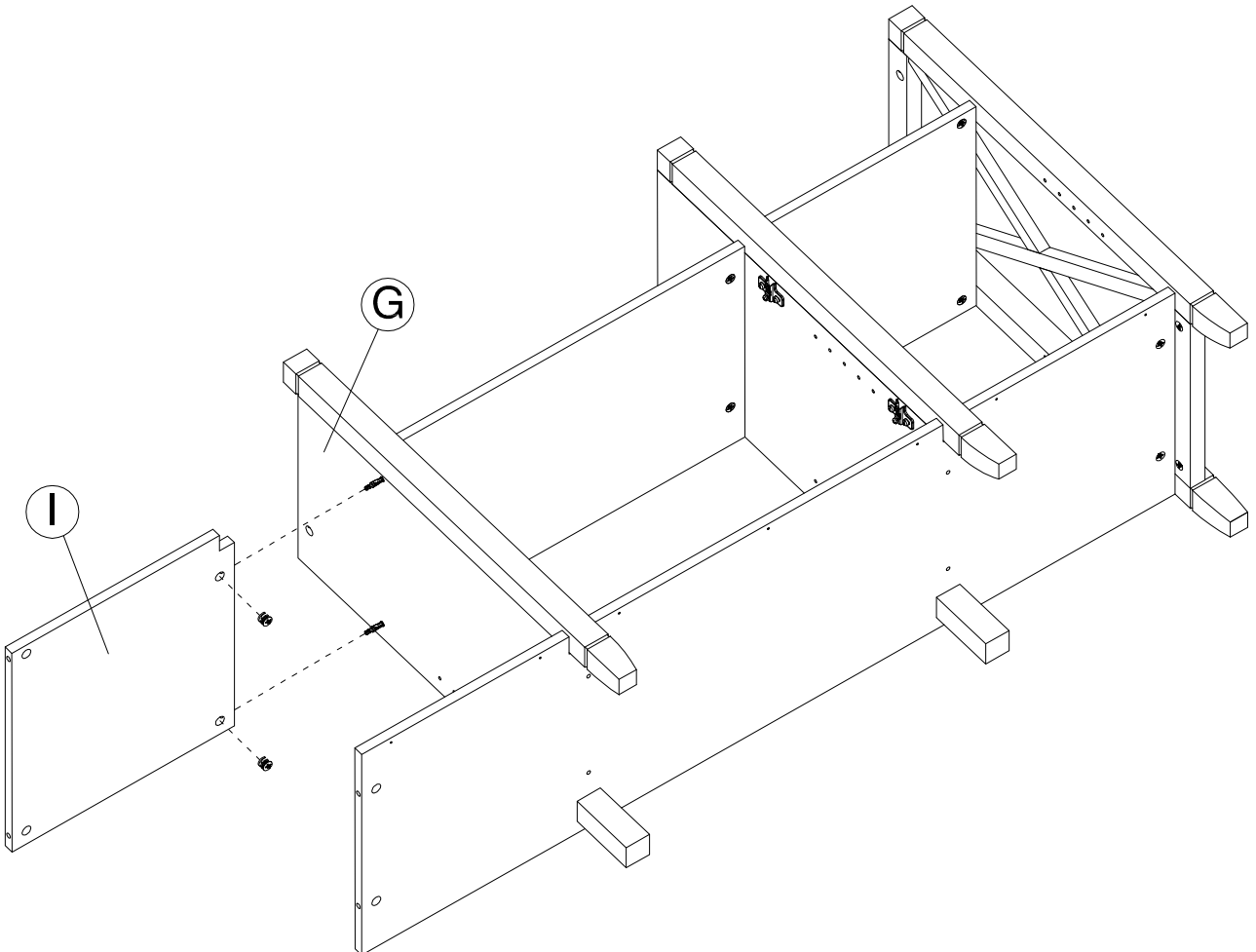
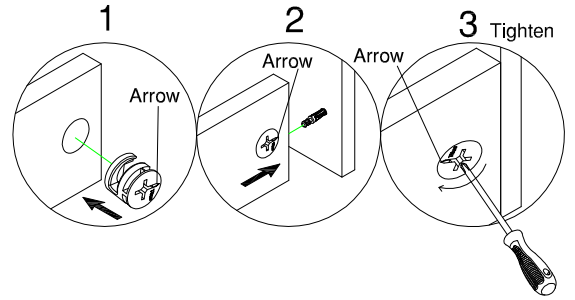

# STEP 15

# Assemble Panels

H181468

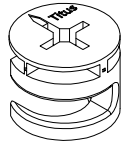

KD Cam

[ 4 ]

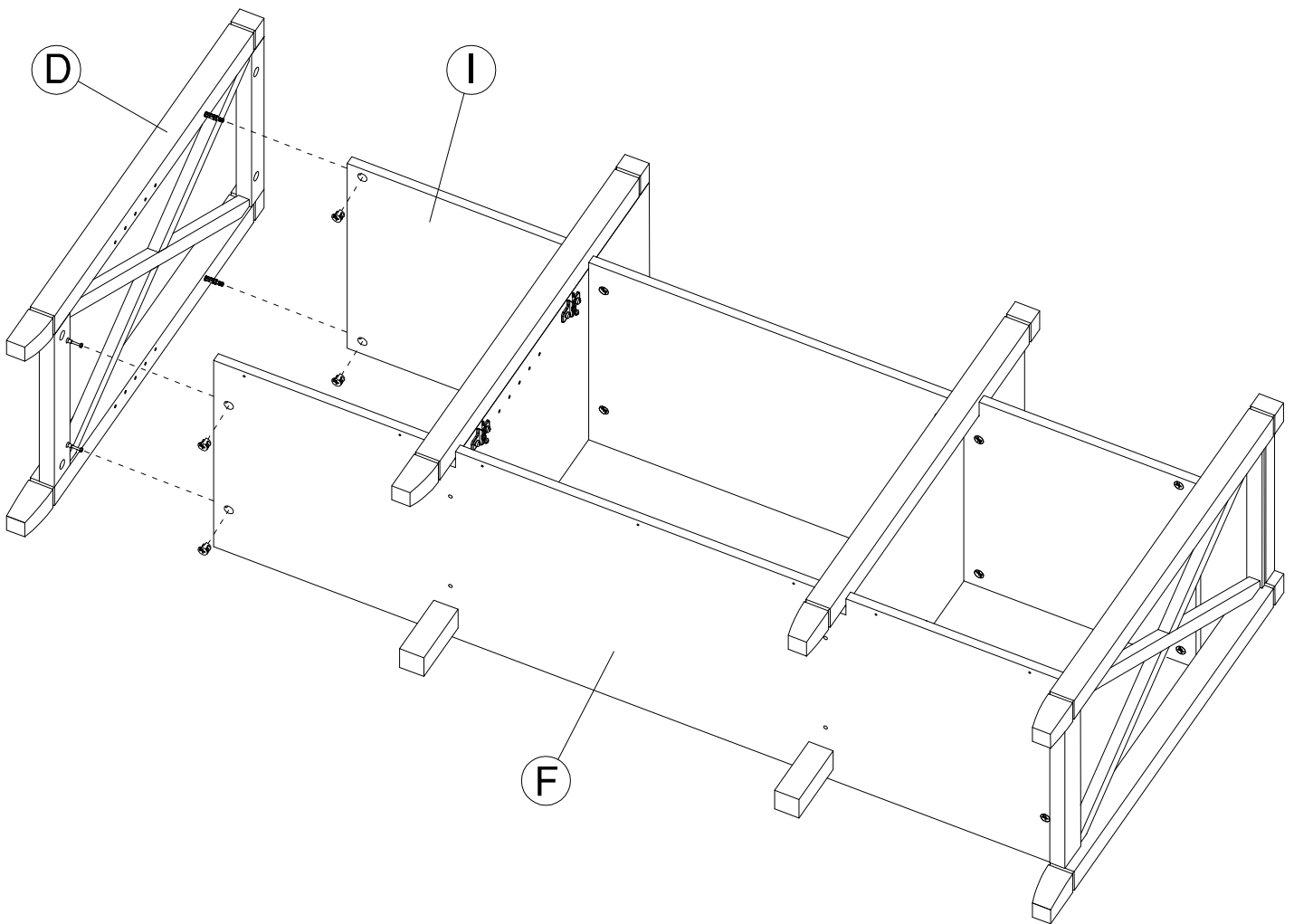
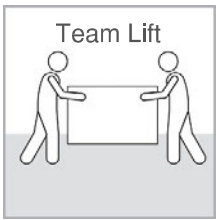
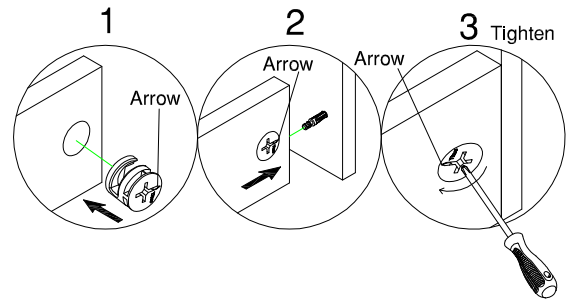

# STEP 16

# Assemble Panels

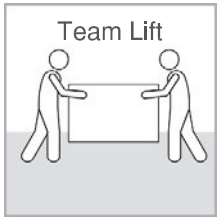

H23370

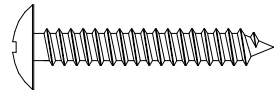

[ 7 ]

#10 x 1-1/4"

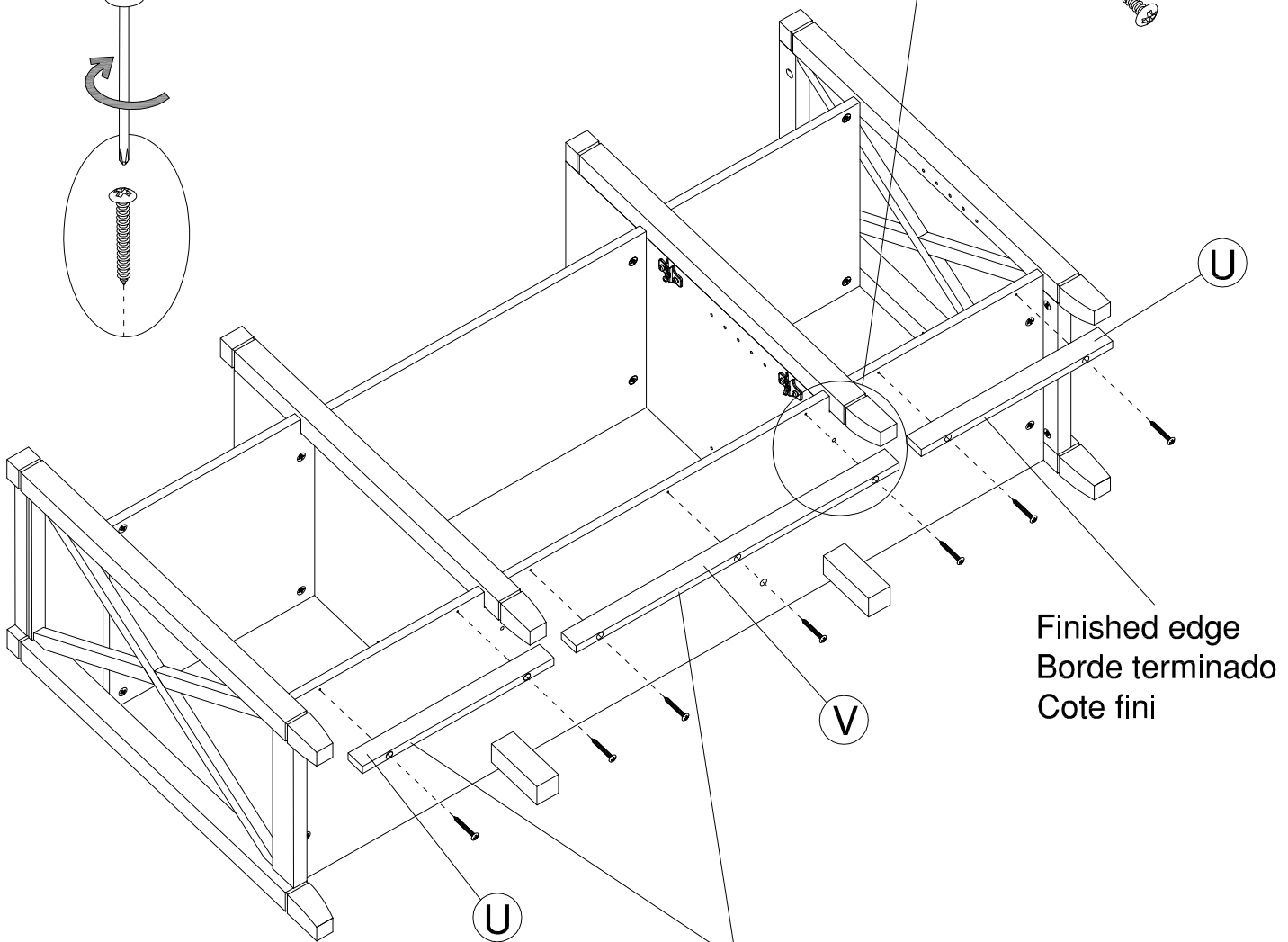
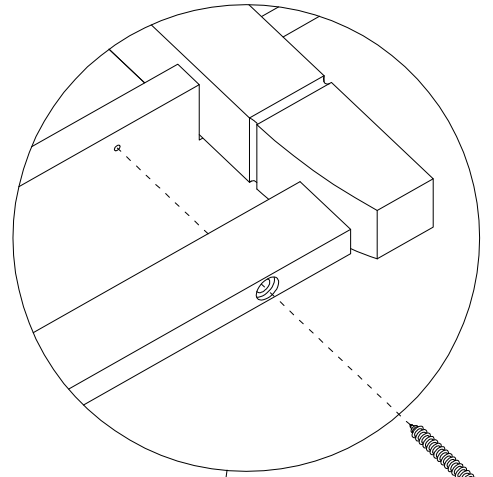
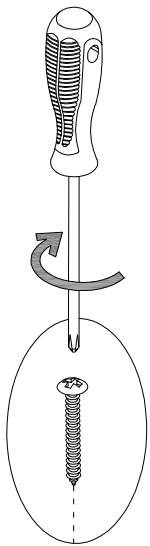

# STEP 17

# Assemble Panels

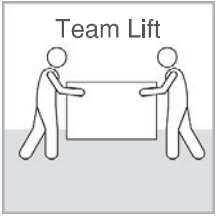

H39922

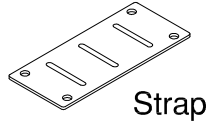

[ 4 ]

H35251

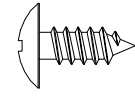

[ 16 ]

#10 x 1/2"

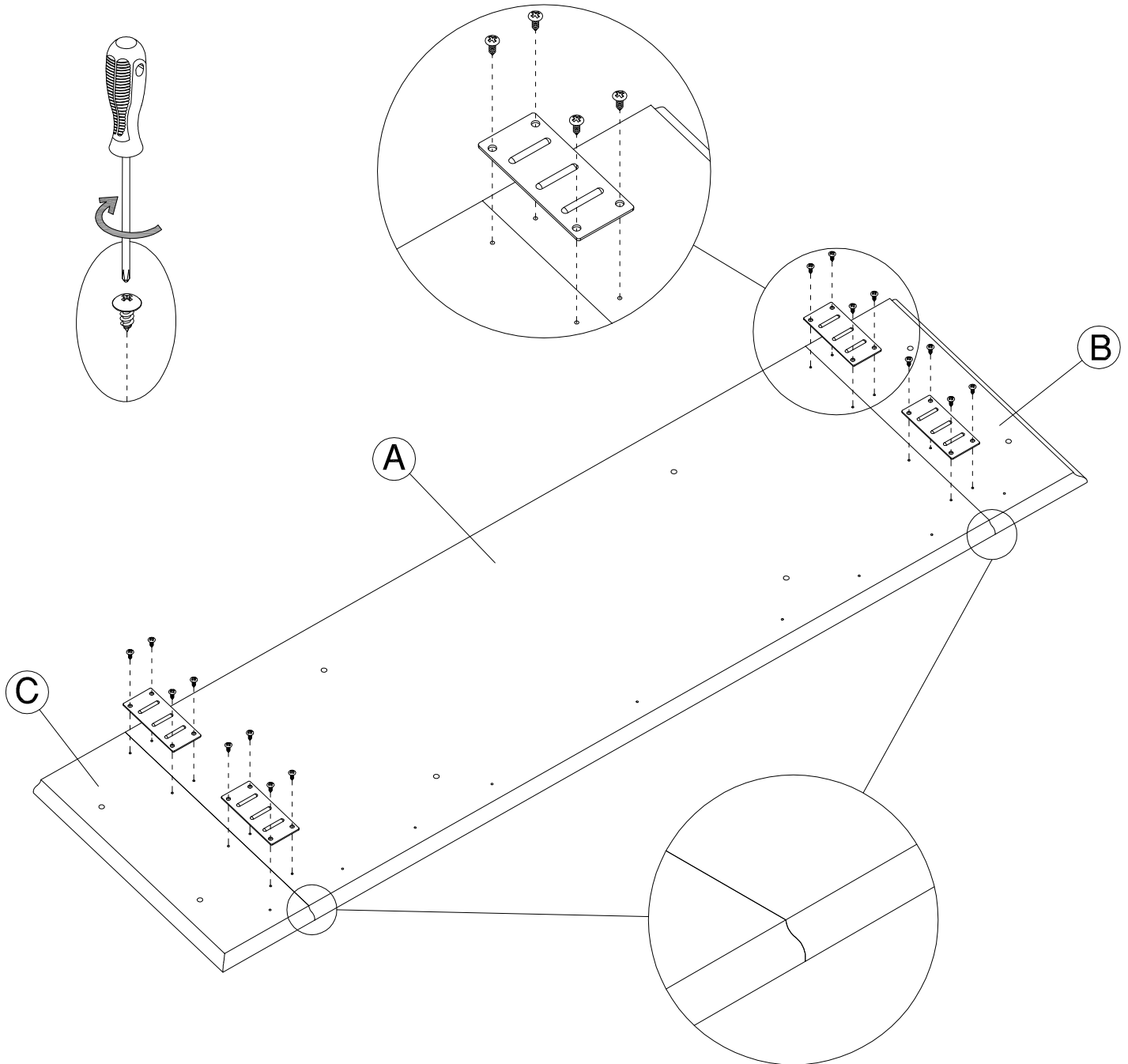

# STEP 18

# Assemble Rails

H23370

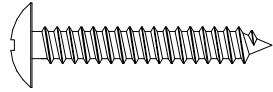

[ 9 ]

#10 x 1-1/4"

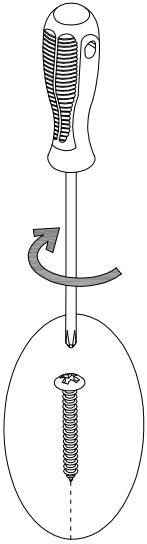

Do not fully tighten.  
No apriete completamente.  
Ne pas viser a fond.

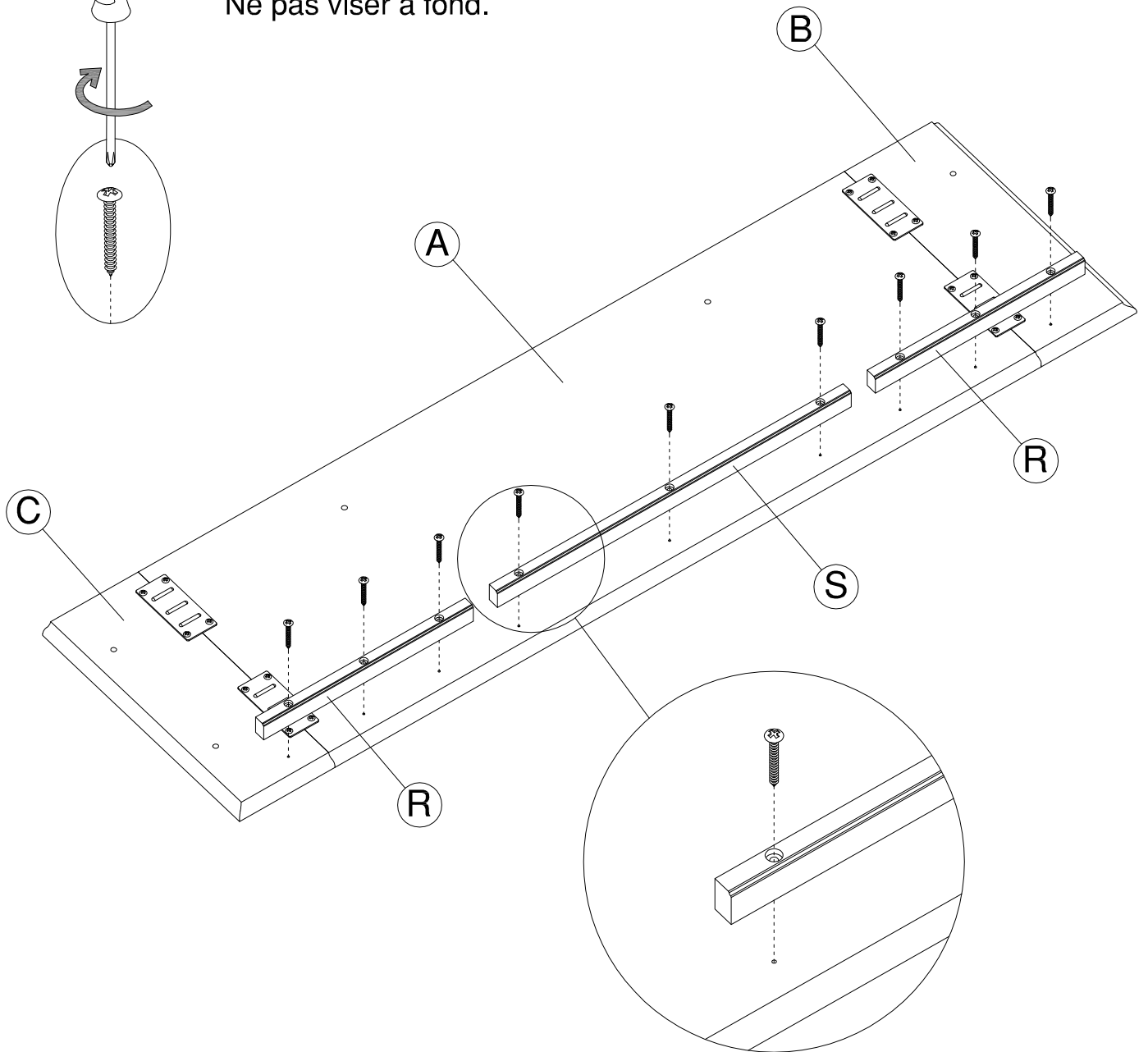

# STEP 19

# Insert Fasteners

H166336

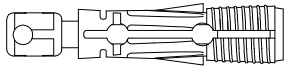

[ 8 ]

Quick Connect

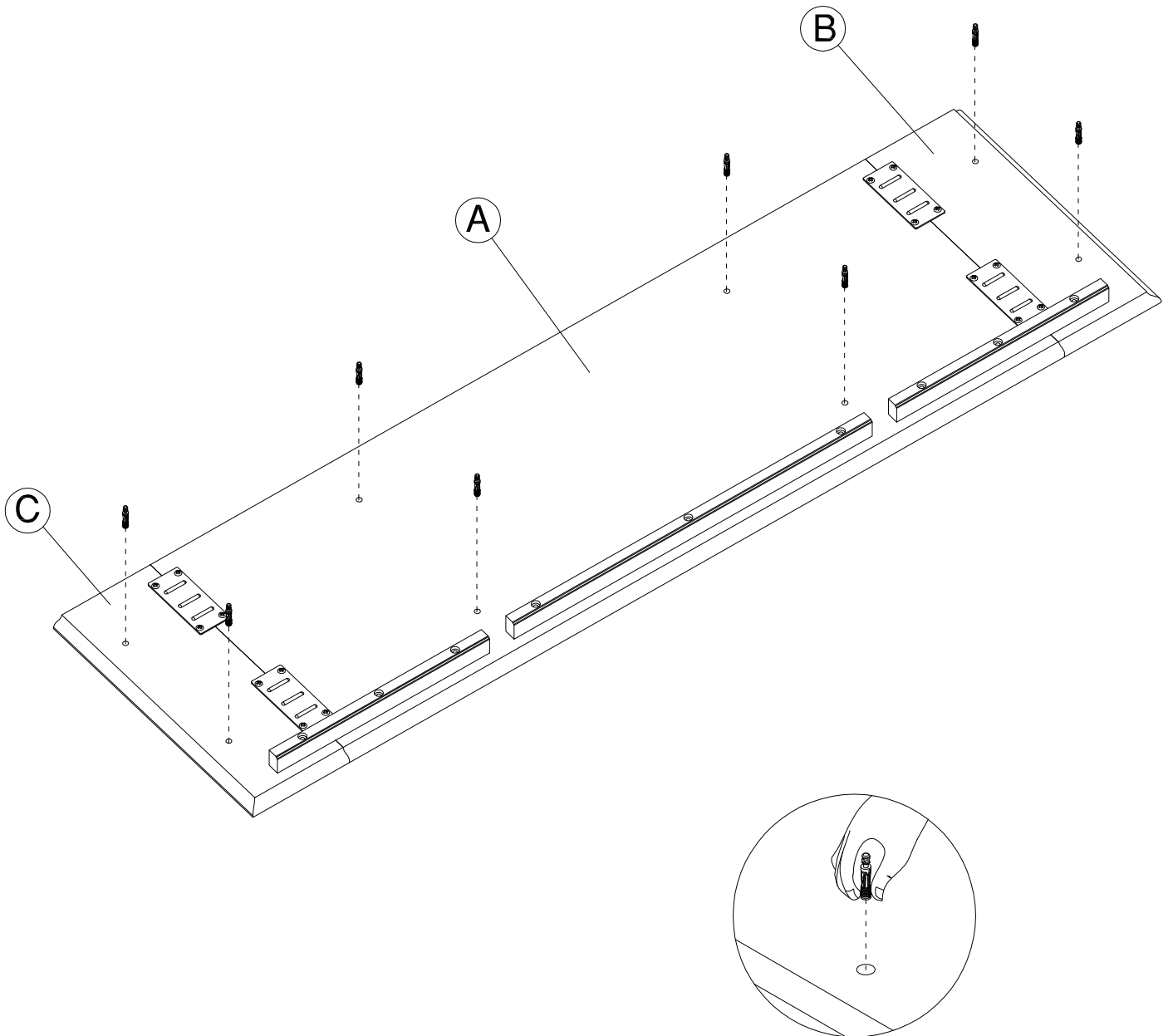

# STEP 20

# Assemble Panels

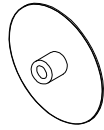

[ 4 ]

Cover Cap

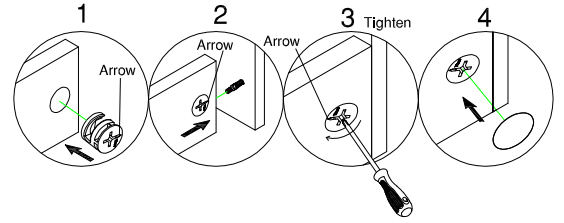

H181468

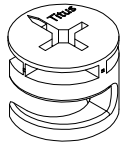

[ 8 ]

KD Cam

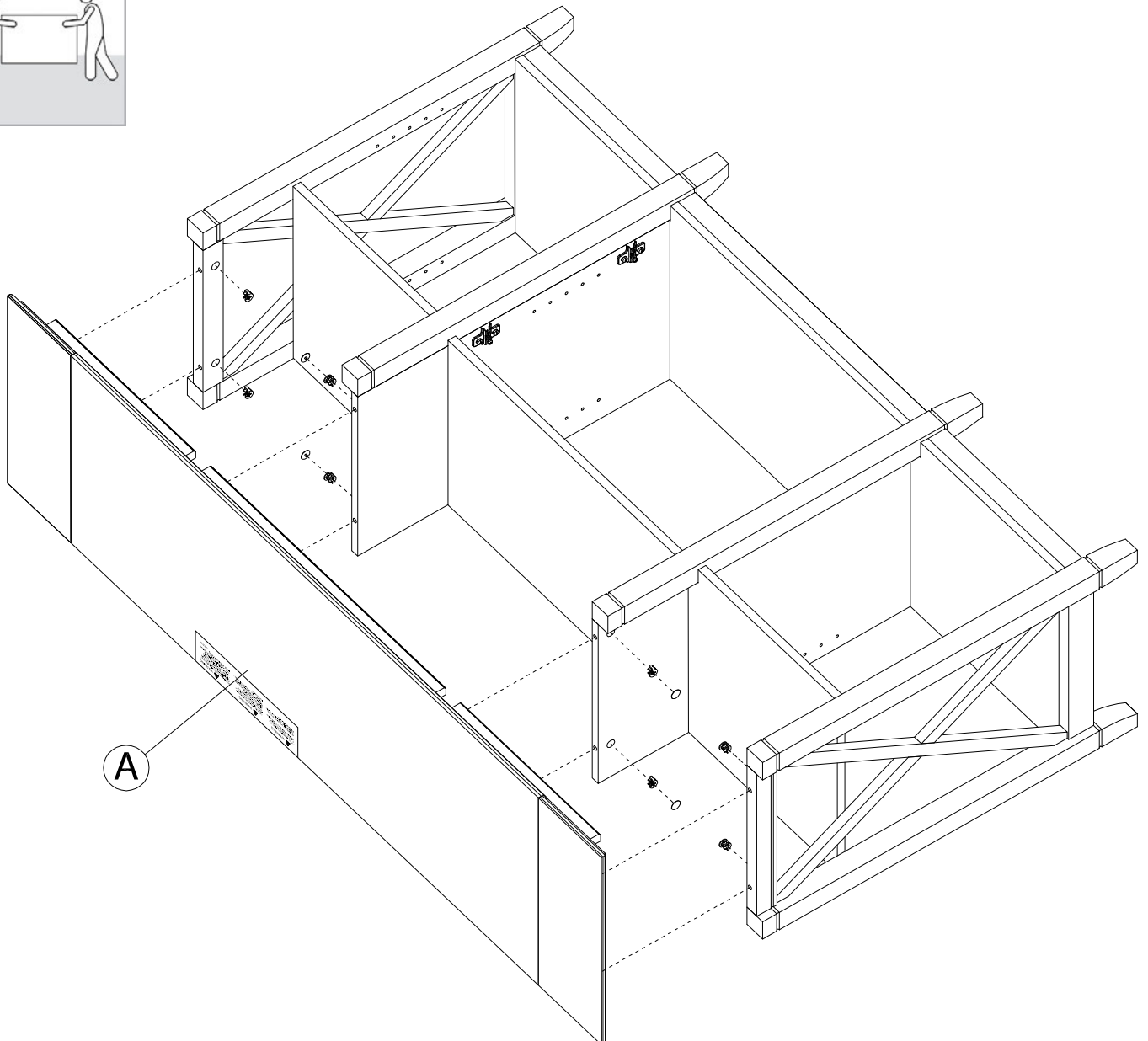
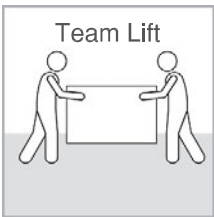

# STEP 21

# Assemble Rails

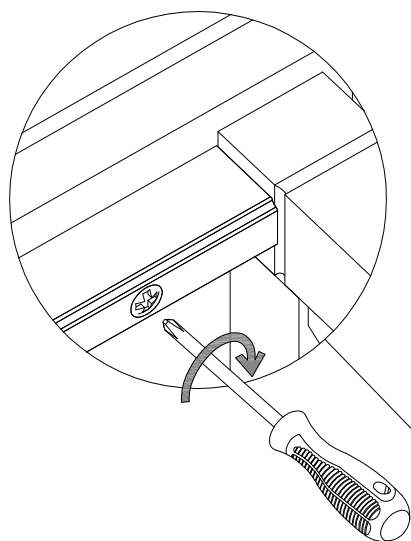

Tighten all screws.  
Apriete todos los tornillos.  
Serrez toutes les vis.

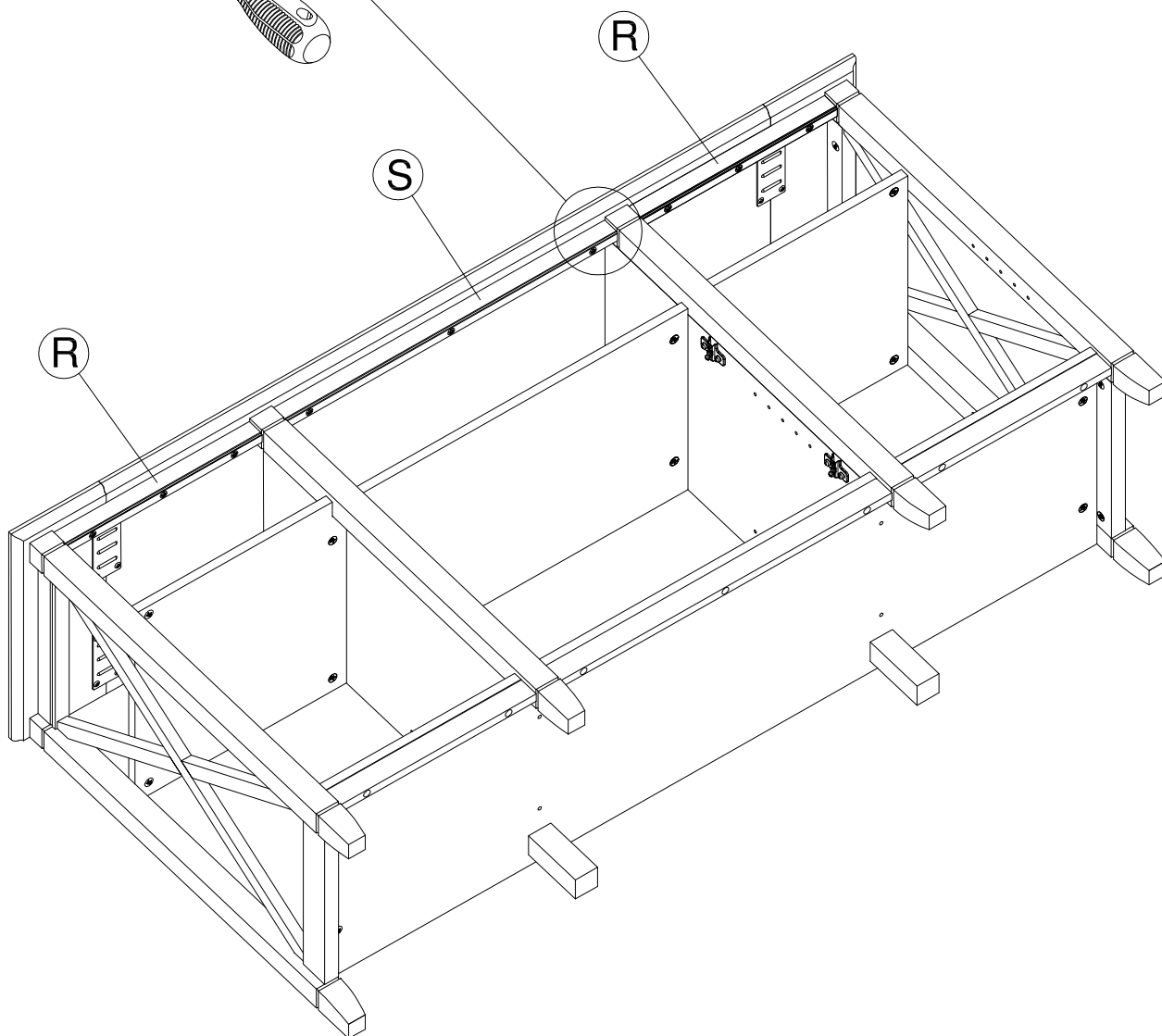

# STEP 22

# Attach Back Panel

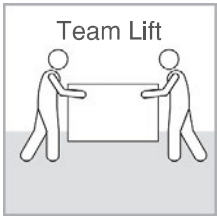

H34174

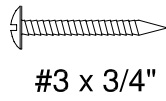

[ 16 ]

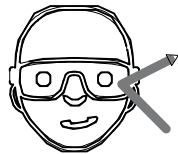

Safety glasses  
Gafas de seguridad  
Lunettes de protection

2mm  
1/16"

2mm  
1/16"

Grain to inside  
Grano para el interior  
Grain de l'intérieur

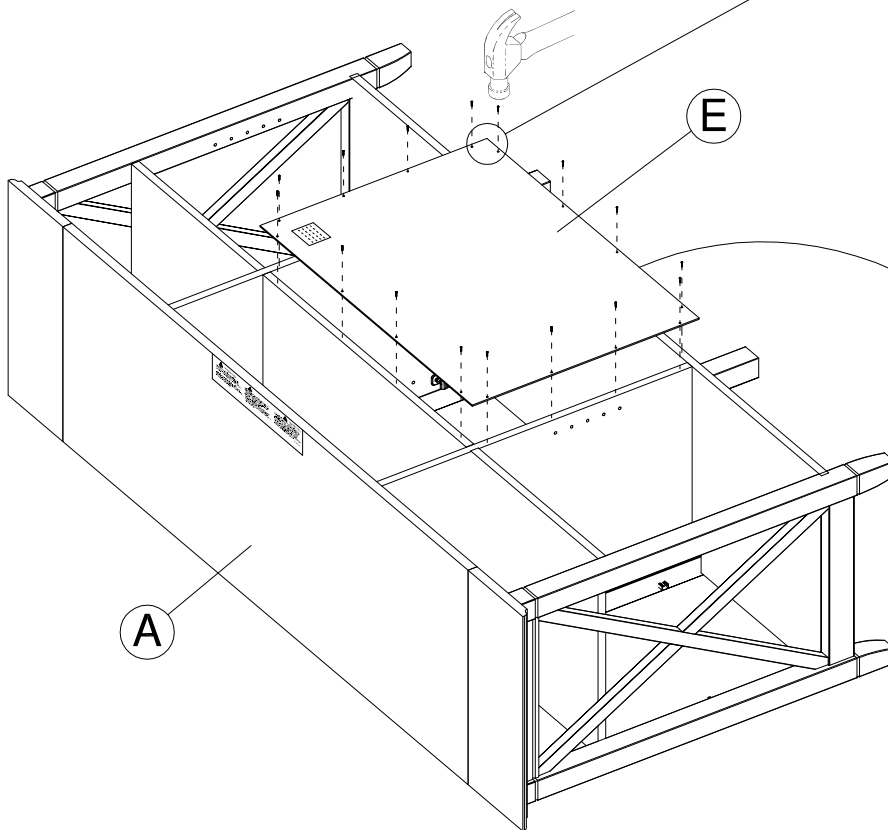

## WARNING

Failure to install every indicated nail and/or screw could lead to excessive shelf sagging or product collapse resulting in serious injury or death.

Si no se instalan todos los clavos y / o tornillos indicados, se podría producir un hundimiento excesivo del estante o el colapso del producto, lo que podría provocar lesiones graves o la muerte.

Le fait de ne pas installer chaque clou et / ou vis indiqué pourrait entraîner un affaissement excessif de l'étagère ou un effondrement du produit, entraînant des blessures graves, voire mortelles.

# STEP 23

# Insert Hardware

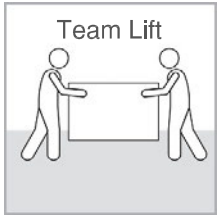

H23604

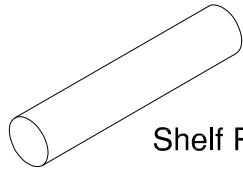

Shelf Pin

[ 12 ]

H126396

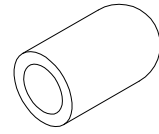

Shelf Pin Sleeve

[ 4 ]

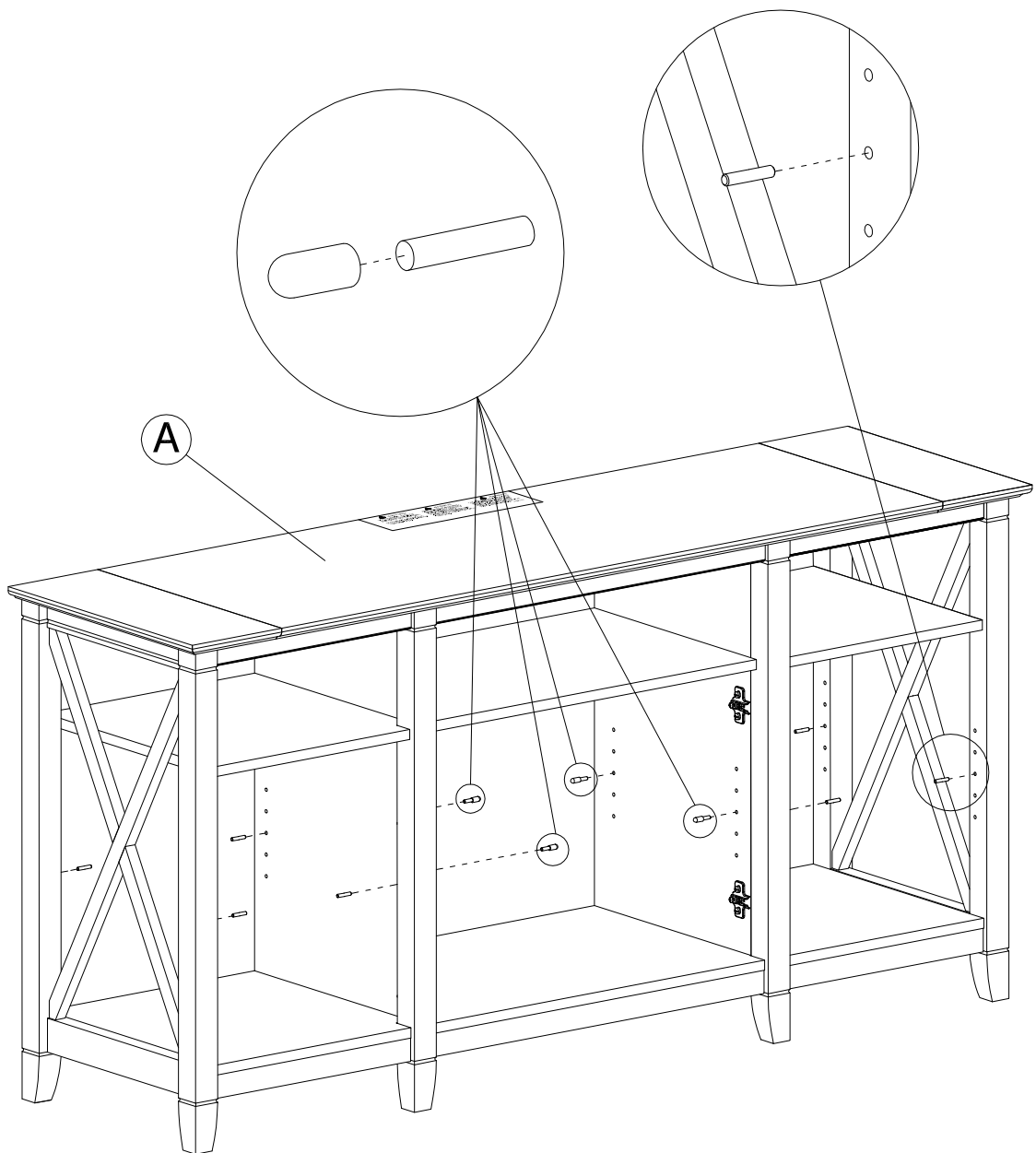

# STEP 24

# Install Shelves

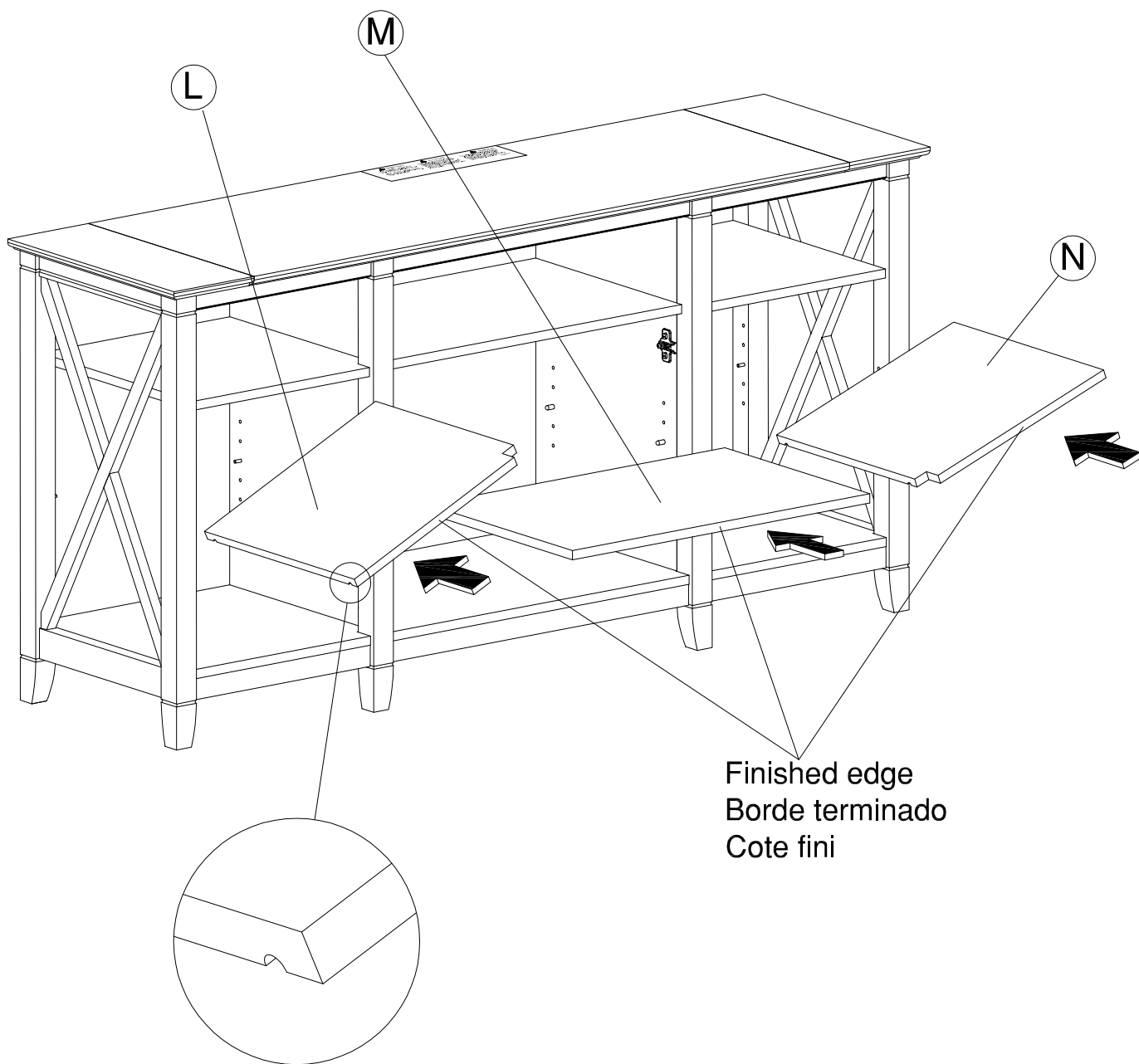

**STEP 25**

**Attach Doors**

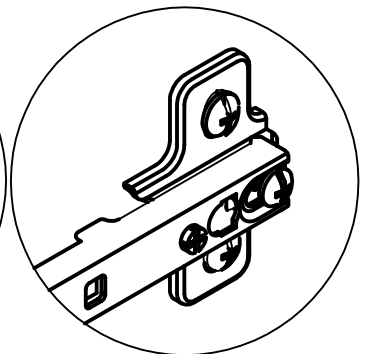
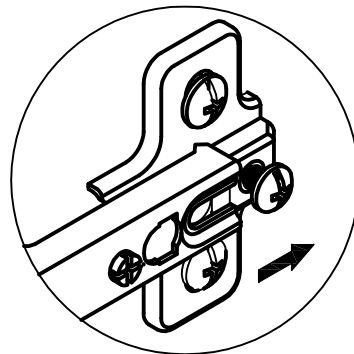
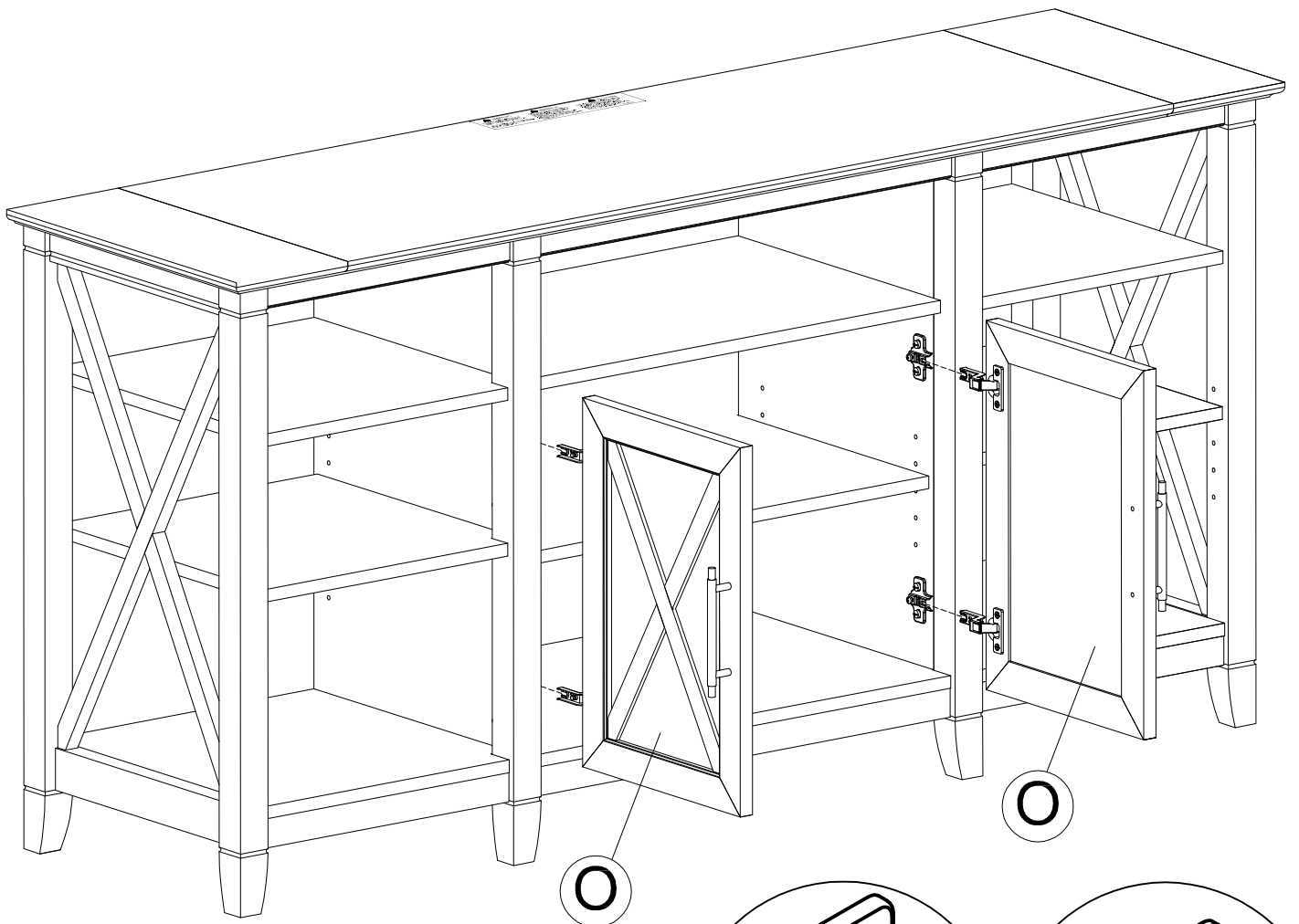
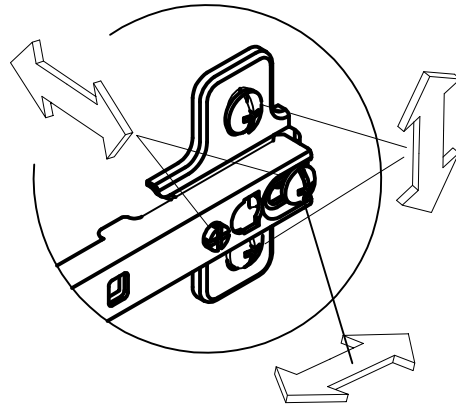

# STEP 26

# Install Hardware

H77351

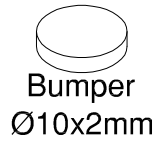

[ 2 ]

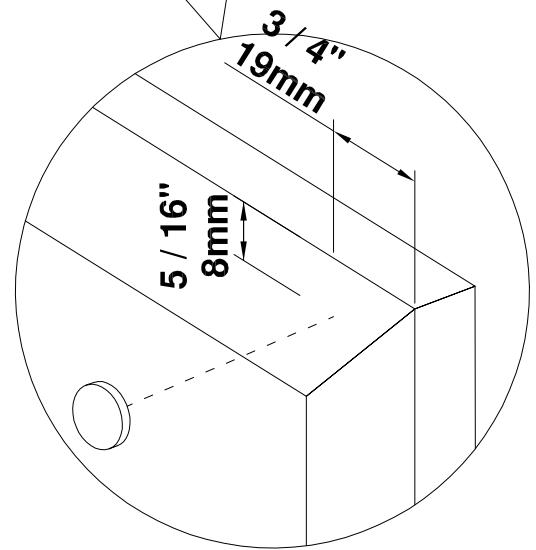
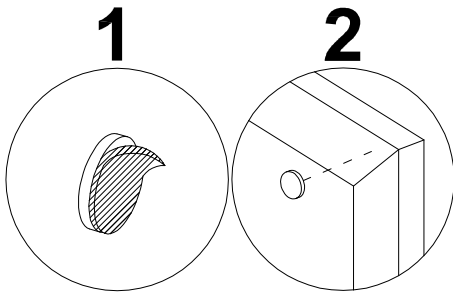
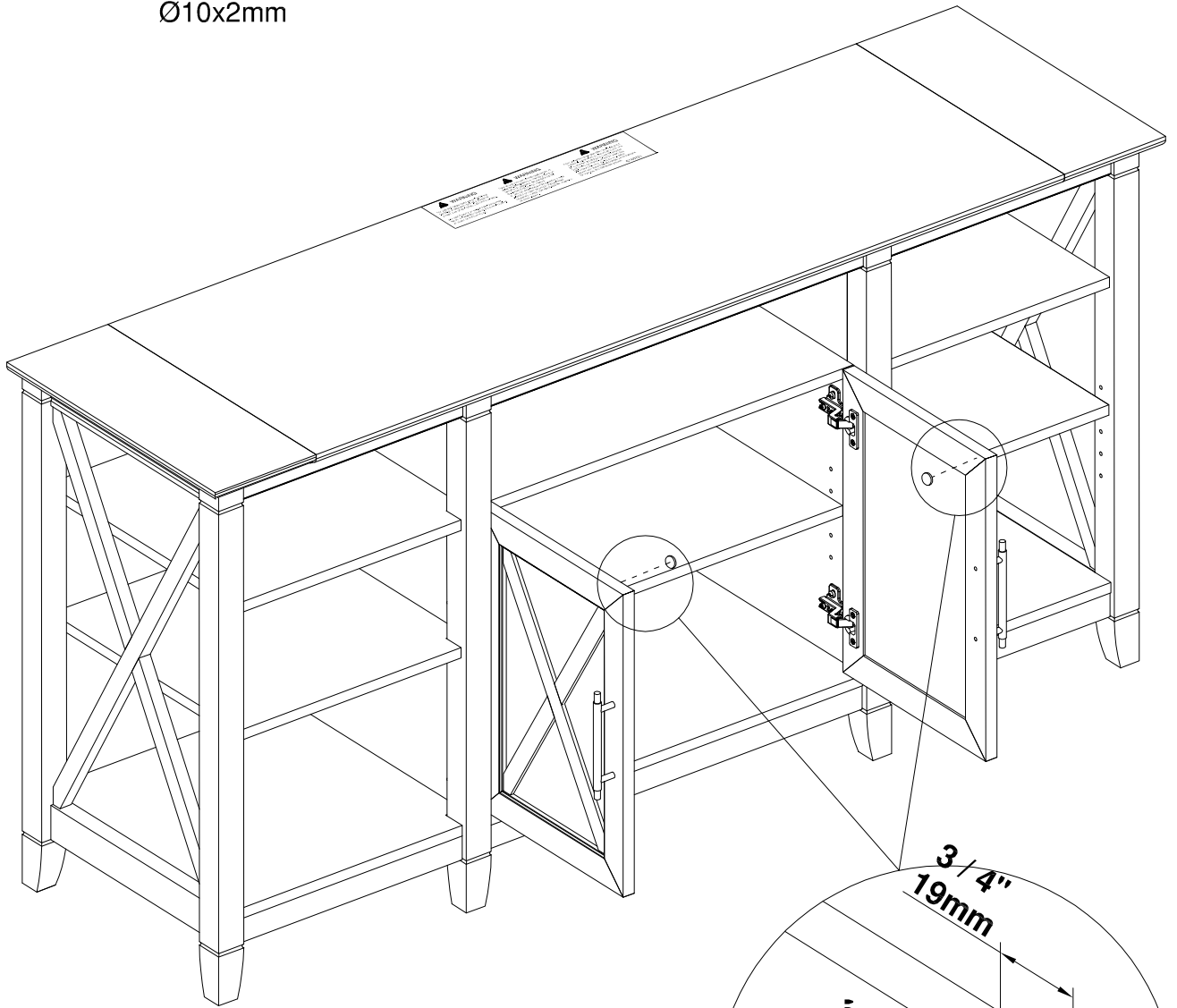

## STEP 27

## Wall Attachment

Secure unit to the wall with a tip-over restraint.

Unidad de seguro a la pared con un sistema de retención de un vuelco.

Fixer l'unité au mur avec un dispositif de retenue renversement.

1. Place unit in desired location.
2. Locate wall stud nearest unit center. **FIG A**
3. On wall, mark center of stud location 1" below top of unit. **FIG A**
4. If a wall stud cannot be located mark hollow wall at unit center. **FIG A**
5. On back of unit, mark corresponding location 3/8" below top of unit. **FIG B**

1. Coloque la unidad en el lugar deseado.
2. Localice pie derecho de pared centro de unidad más próxima.
3. En la pared del, marque el centro de la ubicación del montante 1 "abajo la parte superior de la unidad.
4. Si un poste de la pared no se puede localizar marcar pared hueca en el centro de la unidad.
5. En el dorso de la unidad, marque la ubicación 3/8 correspondiente abajo la parte superior de la unidad.

1. Placez l'unité à l'endroit désiré.
2. Localiser centre d'unité la plus proche de la paroi Stud.
3. Sur le mur, centre de emplacement du montant 1 "ci-dessous dessus de l'appareil de la marque.
4. Si un montant de mur ne peut pas être situé marquer mur creux au centre de l'unité.
5. Le dos de l'appareil, marquer l'emplacement 3/8 correspondant ci-dessous dessus de l'appareil.

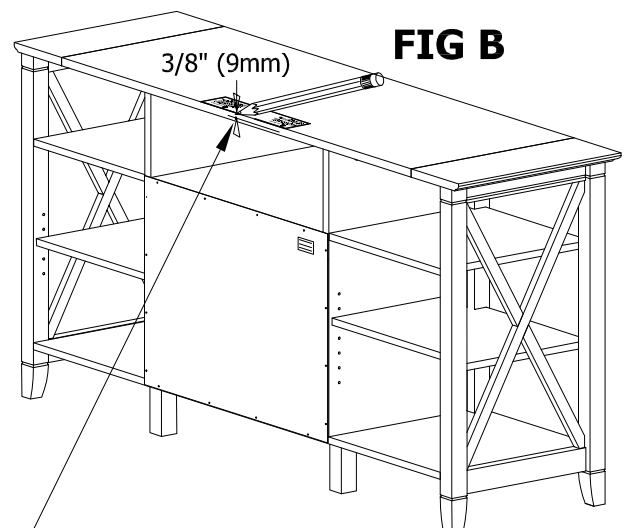
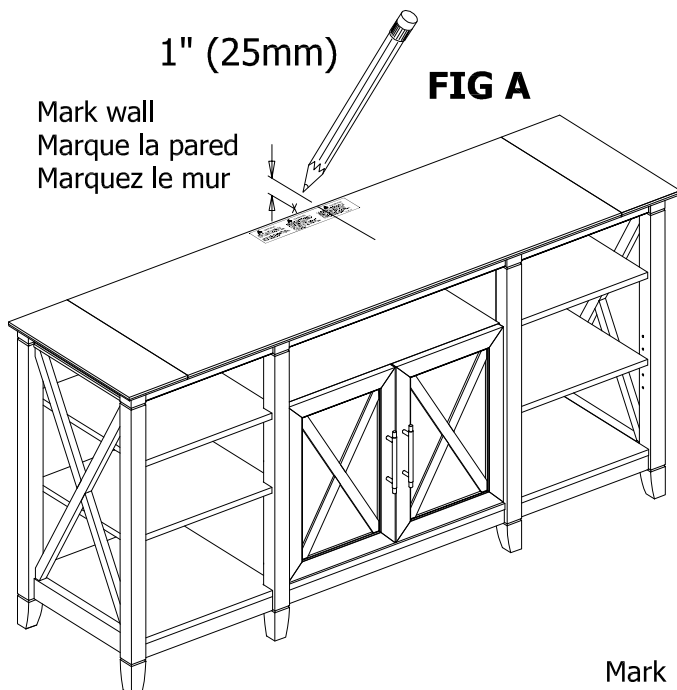

Mark back within 6" (150mm) of center.  
Marcar de vuelta dentro de 6" (150mm) de centro  
Mark dans les 6" (150mm) de centre.

# STEP 28

# Wall Attachment

## WALL STUD ATTACHMENT

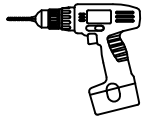

Drill 1/8" hole 2" deep at mark on wall.

Taladro 1/8 "agujero 2" de profundidad en la marca en la pared.

Percer 1/8 "trou de 2" de profondeur à la marque sur le mur.

H181434

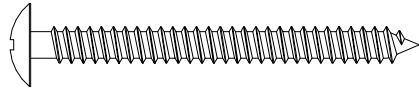

[ 1 ]

#10x2"

H181412

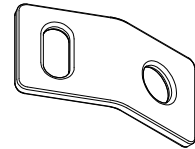

[ 1 ]

Connecting Plate

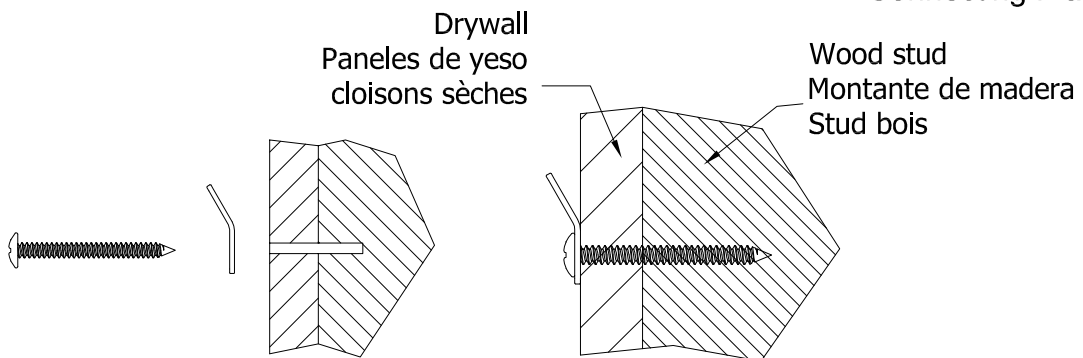

## HOLLOW WALL ATTACHMENT

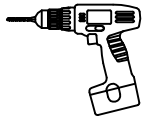

Drill 1/2" hole 1" deep at mark on wall.

Taladro 1/2 "agujero 1" de profundidad en la marca en la pared.

Percer 1/2 "trou de 1" de profondeur à la marque sur le mur.

H181419

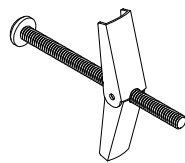

[ 1 ]

Toggle Bolt

H181412

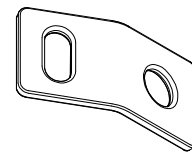

[ 1 ]

Connecting Plate

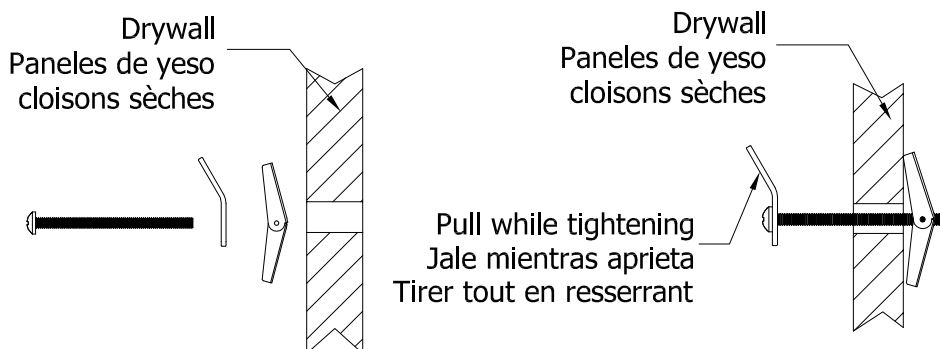

# STEP 29

# Wall Attachment

H107572

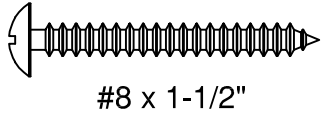

[ 1 ]

#8 x 1-1/2"

H181412

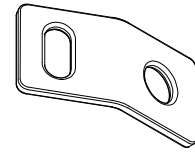

[ 1 ]

Connecting Plate

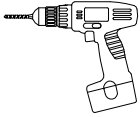

Drill 1/8" hole 1-1/4" deep at mark on unit.

Taladro 1/8 "agujero de 1-1/4" de profundidad en la marca de la unidad.

Perçer 1/8 "trou 1-1/4" de profondeur à la marque sur l'unité.

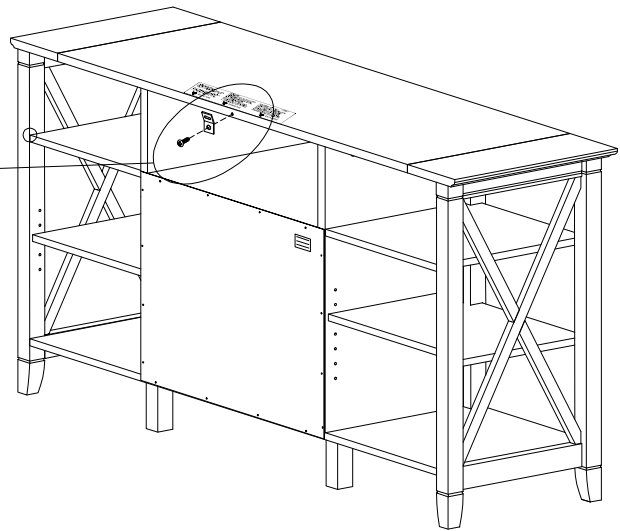
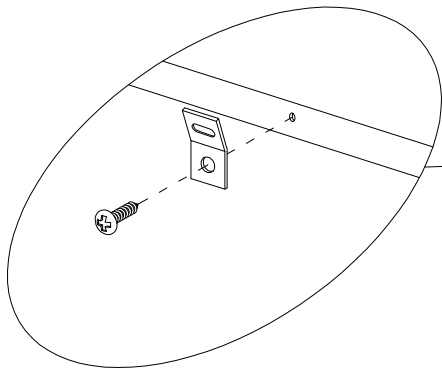

H181411

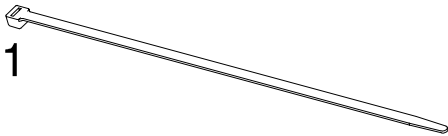

[ 1 ]

Nylon Cable Tie

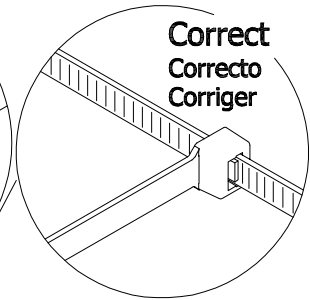
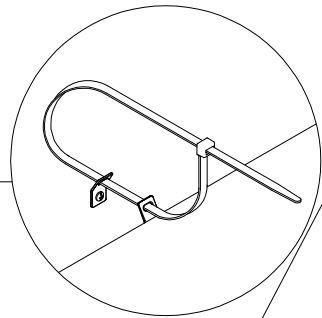
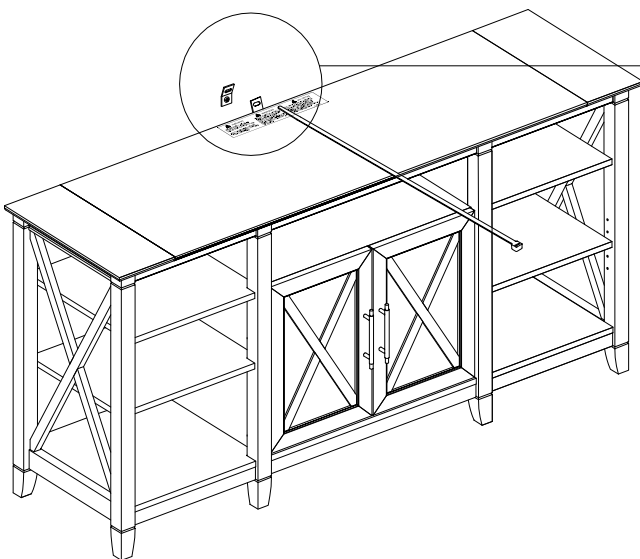

Pull to verify lock

Tire para verificar cerradura

Tirez pour vérifier serrure

Use replacement cable tie with minimum breaking strength of 120lbs.

Utilice reemplazo empaque Cable con resistencia a la rotura mínima de 120 libras.

Utilisez remplacement Attache de câble avec une force de rupture minimale de 120 lbs.

## STEP 30

## Maximum Loading and Cleaning

Gently clean surfaces with a damp sponge eraser.

MAXIMUM TELEVISION WIDTH:  
65 INCHES (1651 MM)

ANCHO DE LA TELEVISIÓN MÁXIMA:  
65 PULGADAS (1651 MM)

LARGEUR DE TÉLÉVISION MAXIMALE:  
65 POUCES (1651 MM)

MAXIMUM WEIGHT: 60 LBS (27.2 KG)  
PESO MÁXIMO: 60 LIBRAS (27.2 KILOGRAMO)  
POIDS MAXIMUM: 60 LIVRES (27.2 KILOGRAMME)

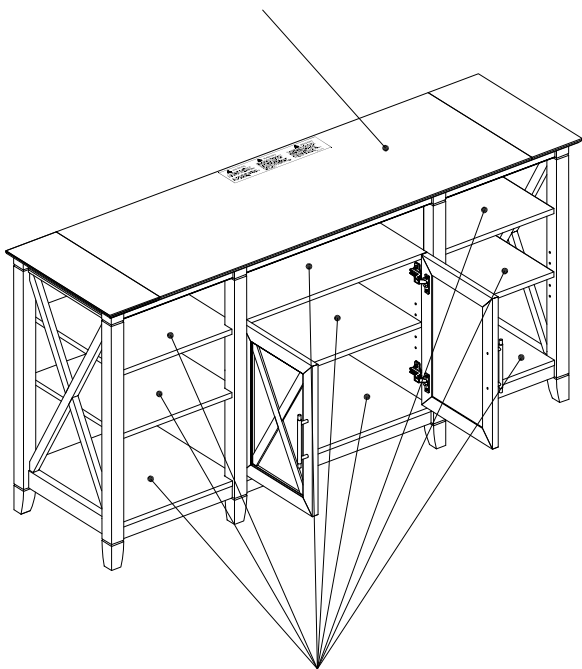

MAXIMUM WEIGHT: 25 LBS (11.34KG)  
PESO MÁXIMO: 25 LIBRAS (11.34KILOGRAMO)  
POIDS MAXIMUM: 25 LIVRES (11.34 KILOGRAMME)

**WARNING** - Death or serious injury may occur when children climb on audio and/or video equipment furniture. A remote control or toys placed on the furnishing may encourage a child to climb on the furnishing and as a result the furnishing may tip over on to the child.

**WARNING** - Relocating audio and/or video equipment to furniture not specifically designed to support audio and/or video equipment may result in death or serious injury due to the furnishing collapsing or over turning onto a child.

**ADVERTENCIA** - Pueden ocurrir lesiones graves o la muerte cuando los niños se suben a los muebles del equipo de audio y / o video. Un control remoto o juguetes colocados sobre el mueble pueden alentar al niño a trepar sobre el mueble y, como resultado, el mueble puede volcarse sobre el niño.

**ADVERTENCIA:** reubicar el equipo de audio y / o video en muebles que no estén diseñados específicamente para soportar equipos de audio y / o video puede resultar en la muerte o lesiones graves debido a que el mueble se derrumba o se voltea hacia un niño.

**AVERTISSEMENT** - La mort ou des blessures graves peuvent survenir lorsque des enfants grimpent sur les meubles d'un équipement audio et / ou vidéo. Une télécommande ou des jouets placés sur le meuble peuvent encourager un enfant à grimper sur le meuble et, par conséquent, le mobilier peut basculer sur l'enfant.

**AVERTISSEMENT** - Le déplacement de l'équipement audio et / ou vidéo sur un meuble non spécifiquement conçu pour supporter un équipement audio et / ou vidéo peut entraîner la mort ou des blessures graves en raison de l'effondrement du meuble ou du retournement sur un enfant.

**Congratulations! You are all done. If you have any questions or concerns, please call.**

# PARTS LIST

## KWV160GH

|                 |                 |
|-----------------|-----------------|
| A [ 1 ] W195188 | L [ 1 ] W195199 |
| B [ 1 ] W195189 | M [ 1 ] W195200 |
| C [ 1 ] W195190 | N [ 1 ] W195201 |
| D [ 2 ] S195191 | O [ 2 ] S195202 |
| E [ 1 ] W195192 | P [ 1 ] W195203 |
| F [ 1 ] S195193 | Q [ 1 ] W195204 |
| G [ 1 ] W195194 | R [ 2 ] W195205 |
| H [ 1 ] W195195 | S [ 1 ] W195206 |
| I [ 1 ] W195196 | T [ 2 ] S195207 |
| J [ 1 ] W195197 | U [ 2 ] W195208 |
| K [ 1 ] W195198 | V [ 1 ] W195209 |

H200205

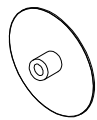

Cover Cap

[ 10 ]

H200219

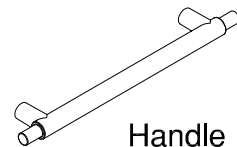

Handle

[ 2 ]

# PARTS LIST

## KWV160RCP

|                 |                 |
|-----------------|-----------------|
| A [ 1 ] W195210 | L [ 1 ] W195221 |
| B [ 1 ] W195211 | M [ 1 ] W195222 |
| C [ 1 ] W195212 | N [ 1 ] W195223 |
| D [ 2 ] S195213 | O [ 2 ] S195224 |
| E [ 1 ] W195214 | P [ 1 ] W195225 |
| F [ 1 ] S195215 | Q [ 1 ] W195226 |
| G [ 1 ] W195216 | R [ 2 ] W195227 |
| H [ 1 ] W195217 | S [ 1 ] W195228 |
| I [ 1 ] W195218 | T [ 2 ] S195229 |
| J [ 1 ] W195219 | U [ 2 ] W195230 |
| K [ 1 ] W195220 | V [ 1 ] W195231 |

H200199

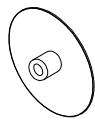

Cover Cap

[ 10 ]

H180971

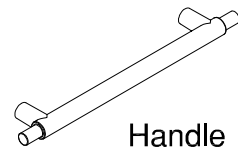

Handle

[ 2 ]

# PARTS LIST

## KWV160LW

|                 |                 |
|-----------------|-----------------|
| A [ 1 ] W195232 | L [ 1 ] W195243 |
| B [ 1 ] W195233 | M [ 1 ] W195244 |
| C [ 1 ] W195234 | N [ 1 ] W195245 |
| D [ 2 ] S195235 | O [ 2 ] S195246 |
| E [ 1 ] W195236 | P [ 1 ] W195247 |
| F [ 1 ] S195237 | Q [ 1 ] W195248 |
| G [ 1 ] W195238 | R [ 2 ] W195249 |
| H [ 1 ] W195239 | S [ 1 ] W195250 |
| I [ 1 ] W195240 | T [ 2 ] S195251 |
| J [ 1 ] W195241 | U [ 2 ] W195252 |
| K [ 1 ] W195242 | V [ 1 ] W195253 |

H200203

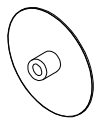

Cover Cap

[ 10 ]

H180971

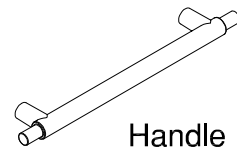

Handle

[ 2 ]

# PARTS LIST

A [ 1 ] W195254  
B [ 1 ] W195255  
C [ 1 ] W195256  
D [ 2 ] S195257  
E [ 1 ] W195258  
F [ 1 ] S195259  
G [ 1 ] W195260  
H [ 1 ] W195261  
I [ 1 ] W195262  
J [ 1 ] W195263  
K [ 1 ] W195264

L [ 1 ] W195265  
M [ 1 ] W195266  
N [ 1 ] W195267  
O [ 2 ] S195268  
P [ 1 ] W195269  
Q [ 1 ] W195270  
R [ 2 ] W195271  
S [ 1 ] W195272  
T [ 2 ] S195273  
U [ 2 ] W195274  
V [ 1 ] W195275

H186180

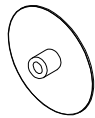

Cover Cap

[ 10 ]

H200219

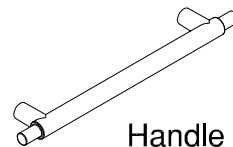

Handle

[ 2 ]

# PARTS LIST

A [ 1 ] W197145  
B [ 1 ] W197146  
C [ 1 ] W197147  
D [ 2 ] S197148  
E [ 1 ] W197149  
F [ 1 ] S197150  
G [ 1 ] W197151  
H [ 1 ] W197152  
I [ 1 ] W197153  
J [ 1 ] W197154  
K [ 1 ] W197155

L [ 1 ] W197156  
M [ 1 ] W197157  
N [ 1 ] W197158  
O [ 2 ] S197159  
P [ 1 ] W197160  
Q [ 1 ] W197161  
R [ 2 ] W197162  
S [ 1 ] W197163  
T [ 2 ] S197164  
U [ 2 ] W197165  
V [ 1 ] W197166

H170595

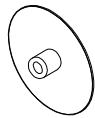

Cover Cap

[ 10 ]

H180971

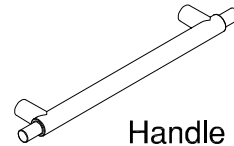

Handle

[ 2 ]

# PARTS LIST

A [ 1 ] W190409

B [ 1 ] W190410

C [ 1 ] W190411

D [ 2 ] S190412

E [ 1 ] W199361

F [ 1 ] S190414

G [ 1 ] W190415

H [ 1 ] W190416

I [ 1 ] W190417

J [ 1 ] W190418

K [ 1 ] W190419

L [ 1 ] W190420

M [ 1 ] W190421

N [ 1 ] W190422

O [ 2 ] S190423

P [ 1 ] W190424

Q [ 1 ] W190425

R [ 2 ] W190426

S [ 1 ] W190427

T [ 2 ] S190428

U [ 2 ] W190429

V [ 1 ] W190430

H180730

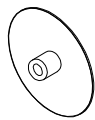

[ 10 ]

Cover Cap

H180971

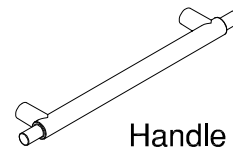

[ 2 ]

Handle

# PARTS LIST

A [ 1 ] W201945  
B [ 1 ] W201946  
C [ 1 ] W201947  
D [ 2 ] S201948  
E [ 1 ] W201949  
F [ 1 ] S201950  
G [ 1 ] W201951  
H [ 1 ] W201952  
I [ 1 ] W201953  
J [ 1 ] W201954  
K [ 1 ] W201955

L [ 1 ] W201956  
M [ 1 ] W201957  
N [ 1 ] W201958  
O [ 2 ] S201959  
P [ 1 ] W201960  
Q [ 1 ] W201961  
R [ 2 ] W201962  
S [ 1 ] W201963  
T [ 2 ] S201964  
U [ 2 ] W201965  
V [ 1 ] W201966

H159346

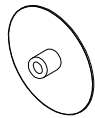

Cover Cap

[ 10 ]

H180971

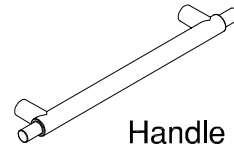

Handle

[ 2 ]

# PARTS LIST

A [ 1 ] W201967

B [ 1 ] W201968

C [ 1 ] W201969

D [ 2 ] S201970

E [ 1 ] W201971

F [ 1 ] S201972

G [ 1 ] W201973

H [ 1 ] W201974

I [ 1 ] W201975

J [ 1 ] W201976

K [ 1 ] W201977

L [ 1 ] W201978

M [ 1 ] W201979

N [ 1 ] W201980

O [ 2 ] S201981

P [ 1 ] W201982

Q [ 1 ] W201983

R [ 2 ] W201984

S [ 1 ] W201985

T [ 2 ] S201986

U [ 2 ] W201987

V [ 1 ] W201988

H192368

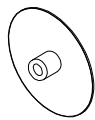

Cover Cap

[ 10 ]

H180971

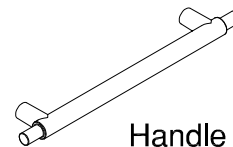

Handle

[ 2 ]

# WARRANTY INFORMATION/INFORMATIONS POUR LA GARANTIE/INFORMACIÓN DE GARANTÍA

## WRITTEN WARRANTY TO YOU

In order to provide you with timely assistance, please thoroughly inspect your furniture for missing or defective parts immediately after opening the carton. To receive replacement or missing parts under this warranty,

Please have the Model, Part, and Lot Numbers found in the instruction manual available for your reference. You will also need your sales receipt or other proof of purchase. Replacement part(s) will be shipped to you at no charge with Bush Industries assuming all shipping and handling charges.

This Bush Furniture product is warranted to the original purchaser at the time of purchase and for a period of one year thereafter.

We warrant to you, the original purchaser, that our furniture and all its parts and components are free of defects in material or workmanship. "Defects," as used in this warranty, is defined as any imperfection which impairs the use of the furniture product.

Our warranty is expressly limited to the replacement of furniture parts and components. For one year after the date of purchase, Bush will replace any parts that are defective in material or workmanship.

This warranty applies under conditions of normal use. Our Bush Furniture products are not intended for outdoor use. This warranty does not cover: 1) defects caused by improper assembly or disassembly; 2) defects occurring after purchase due to product modification, intentional damage, accident, misuse, abuse, negligence or exposure to the elements; and 3) labor or assembly costs. Batteries not included in warranty

IMPLIED WARRANTIES, INCLUDING THE WARRANTY OF MERCHANTABILITY, SHALL NOT EXTEND BEYOND THE DURATION OF THE WRITTEN WARRANTY STATED ABOVE, AND IN NO EVENT SHALL BUSH BE LIABLE FOR INCIDENTAL OR CONSEQUENTIAL DAMAGES RESULTING FROM USE OF THE PRODUCT. Some states do not allow a limitation on how long an implied warranty lasts or the exclusion or limitation of incidental or consequential damages, so the above limitation and exclusion may not apply to you.

This warranty gives you specific legal rights. You may also have other rights that may vary from state to state.

## VOTRE GARANTIE

Afin de vous assister rapidement, veuillez inspecter votre mobilier en détail immédiatement après l'ouverture du carton en cas de pièces manquantes ou défectueuses. Pour recevoir une pièce de rechange ou manquante couverte par cette garantie,

de pièce et de lot qui se trouvent dans le manuel d'instruction pour votre référence. Vous aurez également besoin de votre reçu ou d'une autre preuve d'achat. La (les) pièce(s) de rechange vous sera (seront) envoyée(s) sans frais, Bush Industries se chargeant de tous les frais d'expédition.

Tout le produit Bush Furniture est garanti à l'acheteur original à partir de la date d'achat pour une période d'un an.

Nous vous garantissons, à vous l'acheteur original, que notre mobilier et toutes ses pièces et composants sont sans défaut de matériau ou de fabrication. Le terme "défauts" utilisé dans cette garantie, est défini comme étant toutes les imperfections qui compromettent l'utilisation du meuble.

Notre garantie est expressément limitée au remplacement des pièces et des composants du mobilier. Pendant un an après la date d'achat, Bush remplacera toute pièce défectueuse dans le matériau ou sa fabrication.

Cette garantie d'applique sous des conditions d'utilisation normale. Nos produits ne sont pas destinés à être utilisés en plein air. Cette garantie ne couvre pas: 1) les défauts causés par un mauvais assemblage ou démontage; 2) les défauts ayant lieu après l'achat et dus à la modification du produit, des dommages intentionnels, des accidents, une mauvaise utilisation, un mauvais traitement, la négligence ou l'exposition aux éléments, et 3) les frais de main d'œuvre ou d'assemblage. Piles non incluses dans la garantie.

LES GARANTIES TACITES, Y COMPRIS LA GARANTIE DE QUALITE MARCHANDE, NE S'ETENDRONT PAS AU-DELA DE LA DUREE ECRITE CITEE CI-DESSUS, ET BUSH NE SERA EN AUCUN CAS RESPONSABLE DES DOMMAGES ACCESSOIRES OU INDIRECTS RESULTANT DE L'UTILISATION DU PRODUIT. Certains états ne permettent pas d'appliquer une limite à la durée de la garantie tacite, ni une exclusion ou limitation des dommages accessoires ou indirects; dans ce cas les limitations ou exclusion ci-dessus peuvent ne pas s'appliquer à vous.

Cette garantie vous donne des droits légaux spécifiques. Il se peut que vous ayez également d'autres droits qui peuvent varier d'un état à l'autre.

## GARANTIA ESCRITA DE PARA USTED

Para brindarle asistencia oportuna, por favor, verifique detalladamente que a su mueble no le falte o tenga piezas defectuosas inmediatamente después de abrir la caja. Pararecibir un reemplazo o la parte faltante bajo esta garantía,

tran en el manual de instrucciones disponible para su referencia. Además, necesitará el recibo de su compra u otra prueba de compra. La(s) pieza(s) de reemplazo le será(n) enviada(s) sin recargo por Bush Industries asumiendo los gastos de envío y manipuleo.

Todo mueble de Bush Furniture es garantizado al comprador original al momento de la compra y por un periodo de uno año en adelante.

Le garantizamos a usted, el comprador original, que nuestros muebles sus partes y componentes están libres de defectos en materiales o trabajo. "Defectos", según se usa en esta garantía, se define como una imperfección que perjudica el uso del producto mobiliario.

Nuestra garantía se limita expresamente al reemplazo de partes y componentes mobiliarios. Durante uno año después de la fecha de compra, Bush reemplazará cualquier parte defectuosa en material o trabajo.

Esta garantía se aplica bajo condiciones de uso normal. Nuestros productos de Bush Furniture no son para uso en exteriores. Esta garantía no cubre: 1) defectos causados por un ensamblaje o desensamblaje inadecuado; 2) defectos que ocurran después de la compra debido a modificación del producto, daño intencional, accidente, mal uso, abuso, negligencia o exposición a los elementos; y 3) costos de trabajo o ensamblaje. Baterías no incluidas en la garantía.

LAS GARANTÍAS IMPLICADAS, INCLUYENDO LA GARANTÍA DE COMERCIABILIDAD, NO SE EXTENDERÁN MÁS ALLÁ DE LA DURACIÓN DE LA GARANTÍA ESCRITA MENCIONADA, Y EN NINGÚN CASO BUSH SERÁ RESPONSABLE POR DAÑOS INCIDENTALES O CONSIGUIENTES COMO RESULTADO DEL USO DEL PRODUCTO. Algunos estados no permiten una limitación sobre el tiempo de duración de la garantía implicada o la exclusión o limitación de daños incidentales o consiguientes, de manera que la limitación y exclusión mencionadas pueden no aplicarse para usted.

Esta garantía le otorga derechos legales específicos. Puede también tener otros derechos que pueden variar según los estados.