

# Installation & Assembly

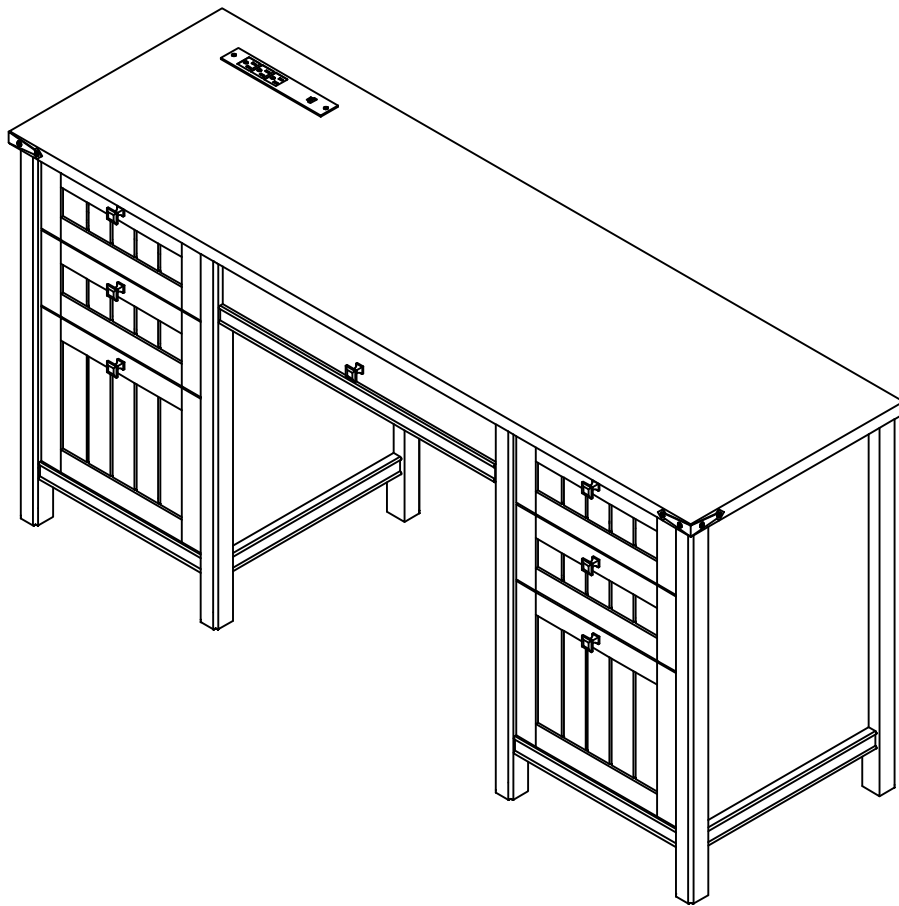

As this item contains many parts, please read the installation instruction carefully before installation . Please use tools properly and carefully. If you have any questions about the product and installation, please contact us.

Our professional after-sales team will serve you online all day.

---

# Before You Start

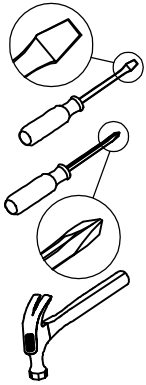

- ✓ Read through each step carefully and follow the proper order
- ✓ Separate and count all your parts and hardware
- ✓ Give yourself enough room for the assembly process
- ✓ Have the following tools: Flat Head Screwdriver, #2 Phillips Head Screwdriver and Hammer
- ✓ Caution: If using a power drill or power screwdriver for screwing, please be aware of to slow down and stop when screw is tight. Failure to do so may result in stripping the screw. (Assembly speed can be increased by using electric screwdriver)

# Helpful Hints

## PEOPLE NEEDED FOR ASSEMBLY: 1-2

- Open your item in the area you plan to keep it to avoid excessive heavy lifting.
- Identify, sort and count the parts before attempting assembly.
- Compression dowels are lightly tapped in with a hammer.
- Slides are labeled with an R (right) and L (left) for proper placement.
- Make sure to always face the point on the top of the Cam Lock towards the outer edge.
- If there is a back panel in the package, please install it to make sure your unit is complete and sturdy.
- Please fix all the screws provided for the back panel which can enhance product stability. If it is difficult to fix it when tightening, it can be fixed with the help of a hammer and then tightened.
- Do NOT use harsh chemicals or abrasive cleaners on this item.
- Never push, pull, or drag your furniture.



---

# Board Identification

Not actual size

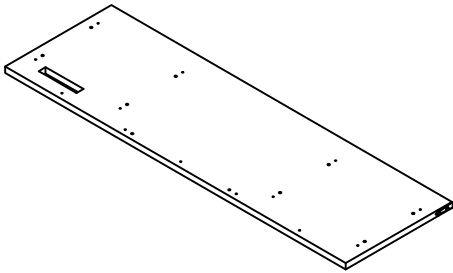

①  
DESK TOP  
Qty:1

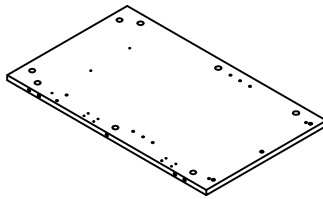

②  
LOWER LEFT SIDE PANEL  
Qty:1

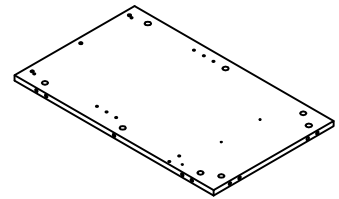

③  
EFT SIDE PARTITION  
Qty:1

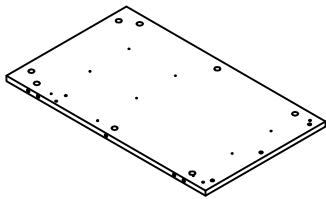

④  
RIGHT SIDE PARTITION  
Qty:1

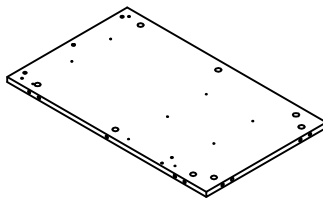

⑤  
LOWER RIGHT SIDE PANEL  
Qty:1

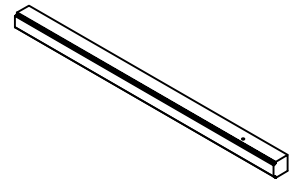

⑥  
LEG  
Qty:2

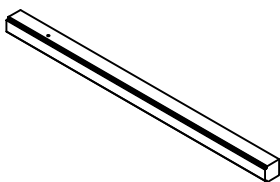

⑦  
LEG  
Qty:2

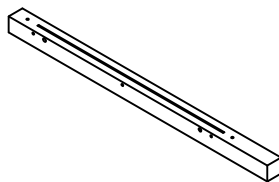

⑧  
LEG  
Qty:1

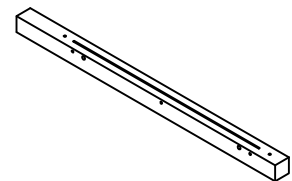

⑨  
LEG  
Qty:1

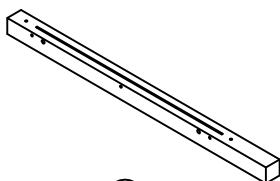

⑩  
LEG  
Qty:1

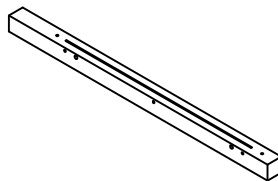

⑪  
LEG  
Qty:1

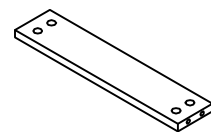

⑫  
FRONT SLAT  
Qty:2

---

# Board Identification

Not actual size

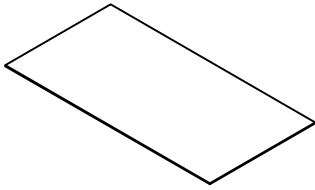

⑬  
BACK PANEL  
Qty:1

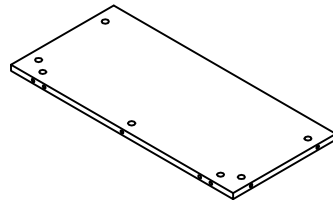

⑭  
BACK SLAT  
Qty:1

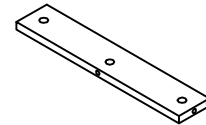

⑮  
BACK SLAT  
Qty:2

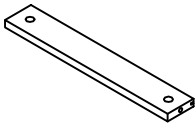

⑯  
BACK SLAT  
Qty:2

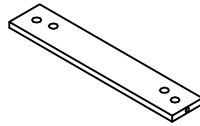

⑰  
BOTTOM LINKING RAIL  
Qty:2

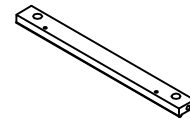

⑱  
BOTTOM FRONT RAIL  
Qty:2

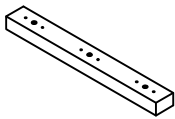

⑲  
FILLER LATH FOR RUNNER  
Qty:2

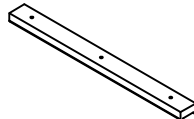

⑳  
DECORATION SLAT  
Qty:4

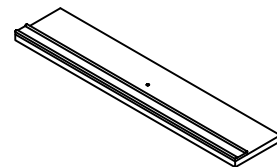

㉑  
DRAWER FRONT PANEL  
Qty:1

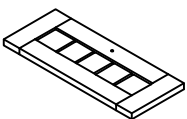

㉒  
FILLER LATH FOR RUNNER  
Qty:3

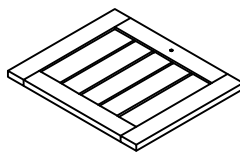

㉓  
DRAWER FRONT PANEL  
Qty:1

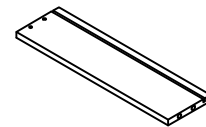

㉔  
DRAWER LEFT SIDE PANEL  
Qty:3

---

# Board Identification

Not actual size

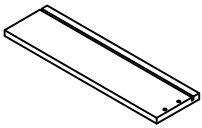

25

DRAWER RIGHT SIDE PANEL  
Qty:3

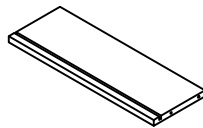

26

DRAWER BACK PANEL  
Qty:3

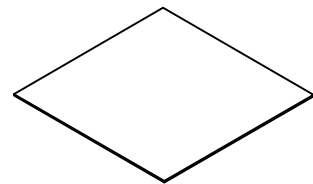

27

DRAWER BOTTOM PANEL  
Qty:3

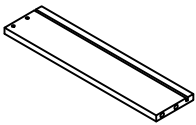

28

DRAWER LEFT SIDE PANEL  
Qty:1

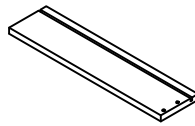

29

DRAWER RIGHT SIDE PANEL  
Qty:1

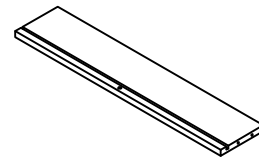

30

DRAWER BACK PANEL  
Qty:1

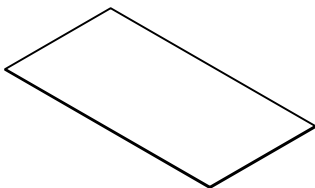

31

DRAWER BOTTOM PANEL  
Qty:1

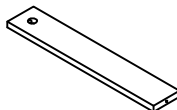

32

DRAWER BOTTOM SLAT  
Qty:1

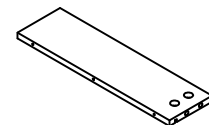

33

DRAWER LEFT SIDE PANEL  
Qty:1

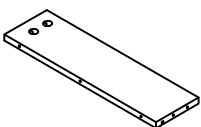

34

DRAWER RIGHT SIDE PANEL  
Qty:1

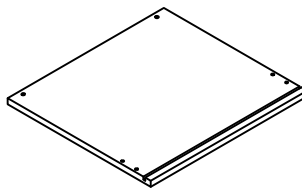

35

DRAWER BACK PANEL  
Qty:1

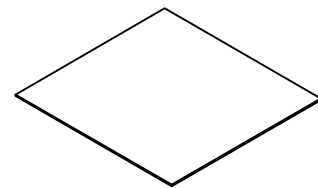

36

DRAWER BOTTOM PANEL  
Qty:1

---

# Board Identification

Not actual size

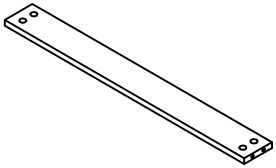

37

FRONT SLAT  
Qty:1

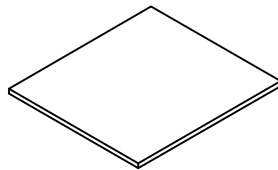

38

SHELF PANEL  
Qty:1

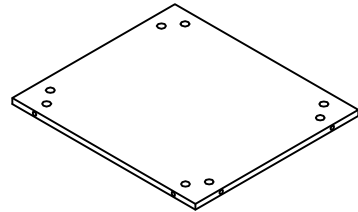

39

EFT BOTTOM  
Qty:1

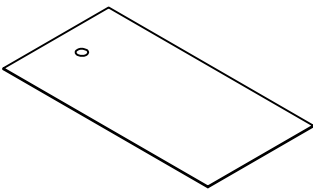

40

BACK PANEL  
Qty:1

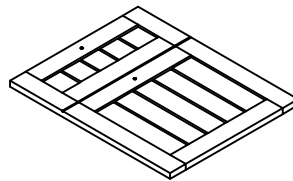

41

DOOR  
Qty:1

# Board Identification

Not actual size

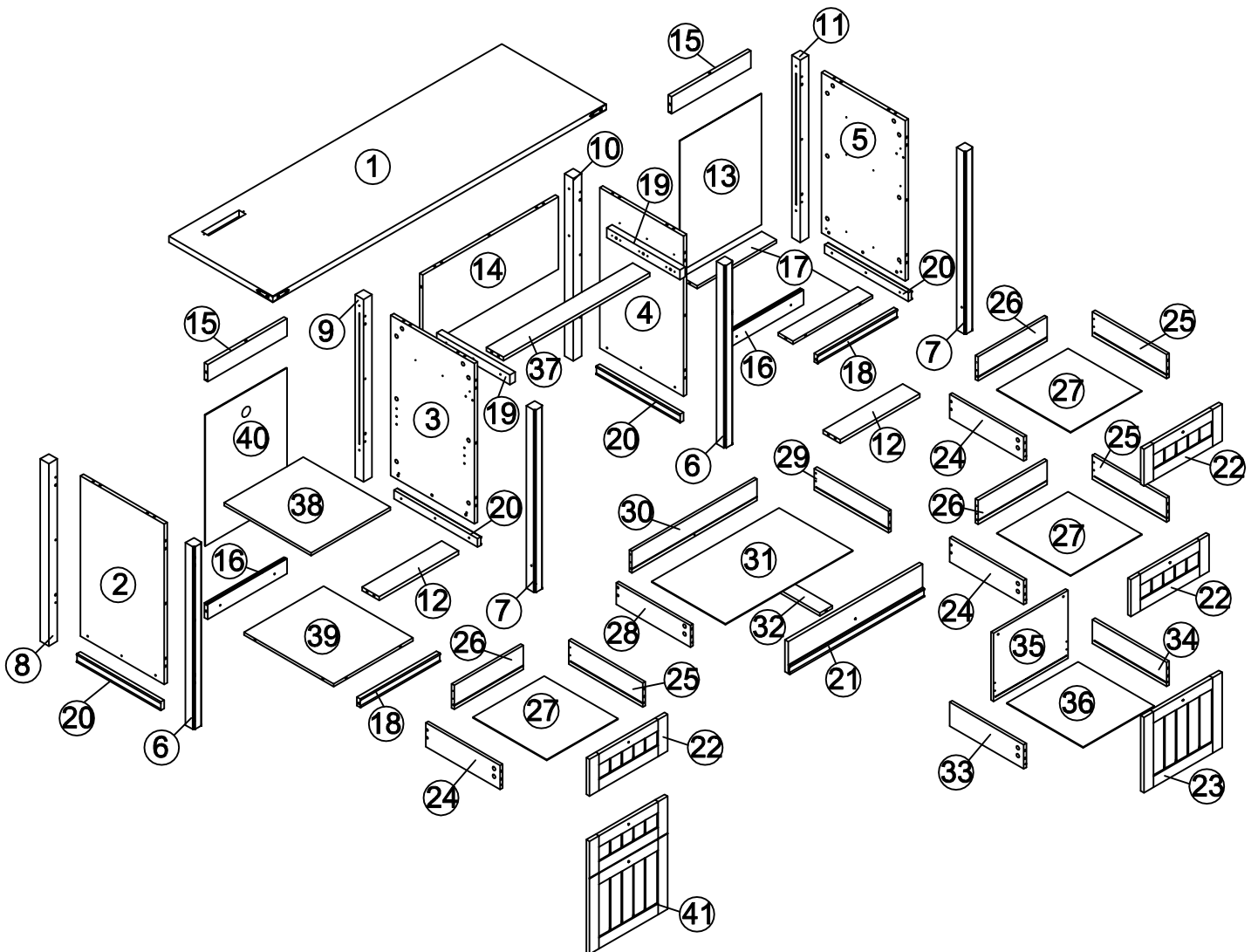

# Part List

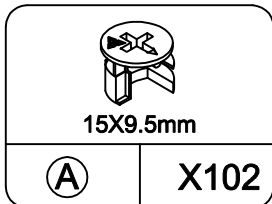

CAM LOCK  
spare:3

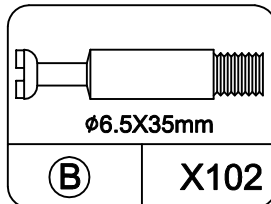

CAM BOLT  
spare:3

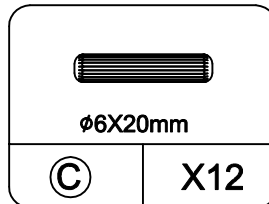

WOOD DOWEL  
spare:2

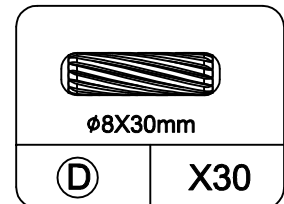

WOOD DOWEL  
spare:2

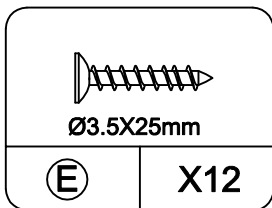

SCREW  
spare:2

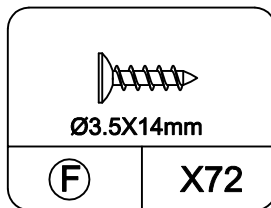

SCREW  
spare:3

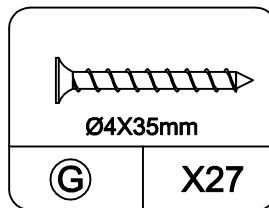

SCREW  
spare:2

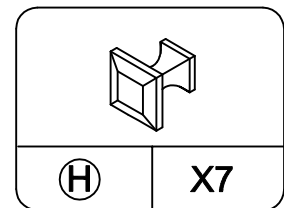

HANDLE

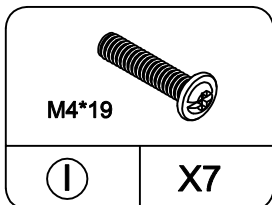

SCREW  
spare:1

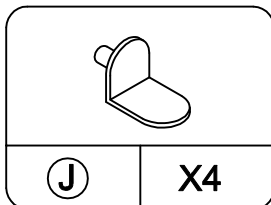

SHELF SUPPORT

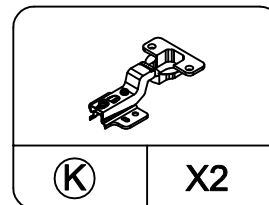

HINGE

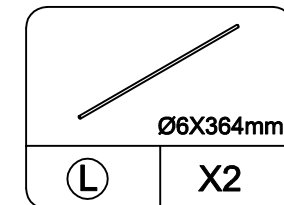

HANDLE

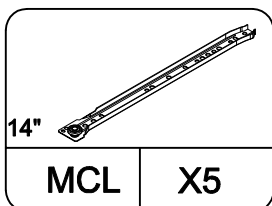

LEFT CABINET MEMBER

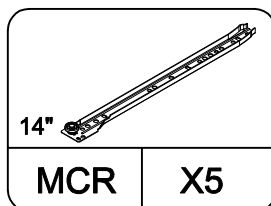

RIGHT CABINET MEMBER

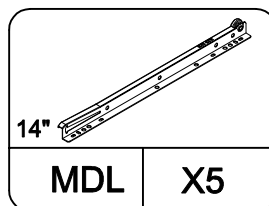

LEFT DRAWER RUNNER

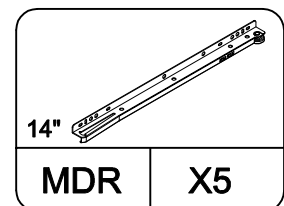

RIGHT DRAWER RUNNER

# Part List

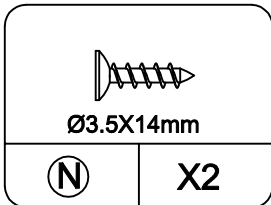

SCREW  
spare:1

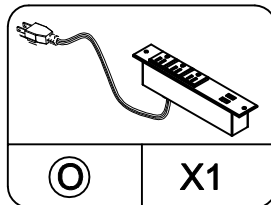

PLUG BOARD

## Cam Lock Fastening System

Insert the cam bolt into the hole first, then insert the cam lock and lock it.

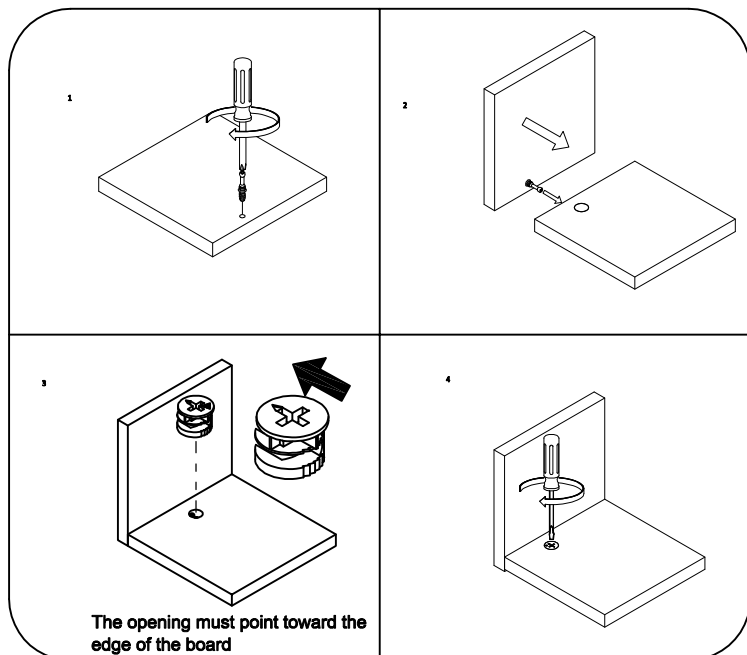

# STEP 1

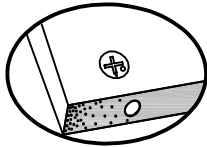
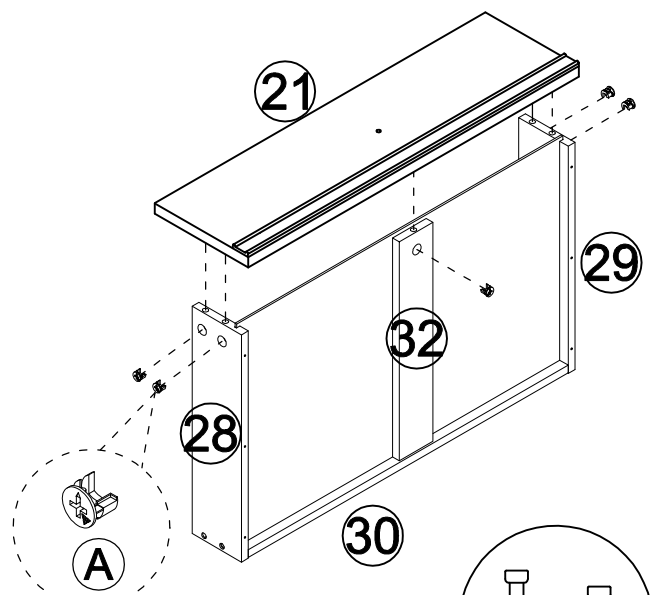
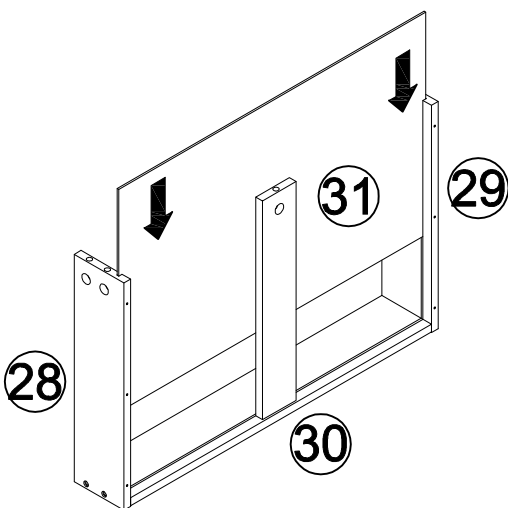
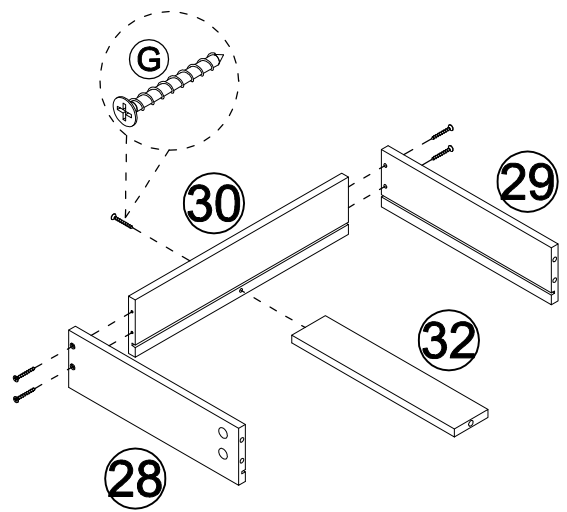
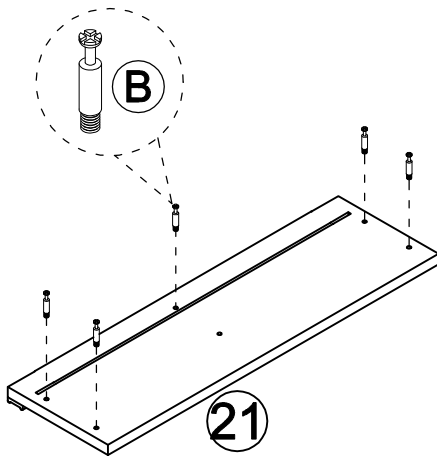
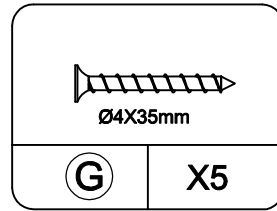
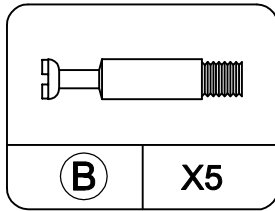
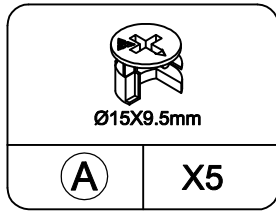
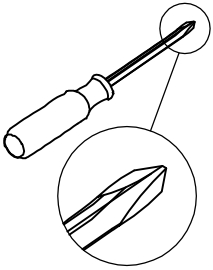

Proper orientation of CAM LOCK

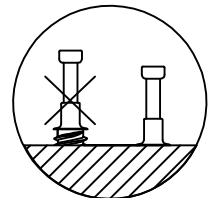

# STEP 2

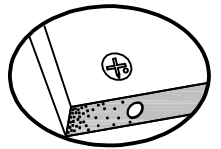
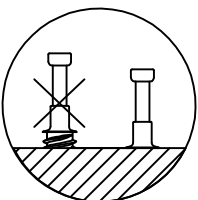
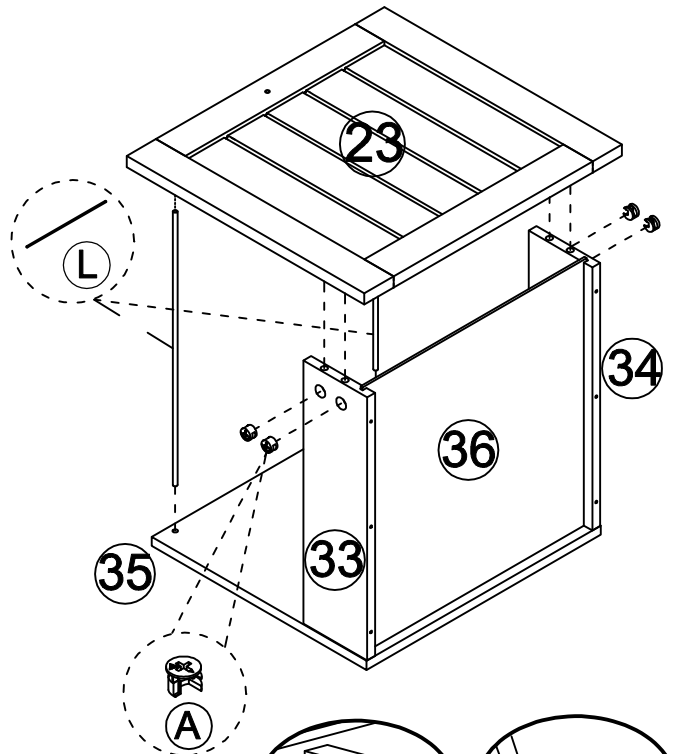
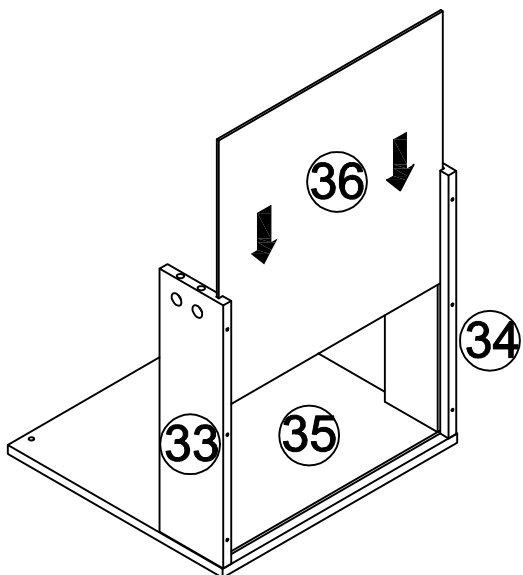
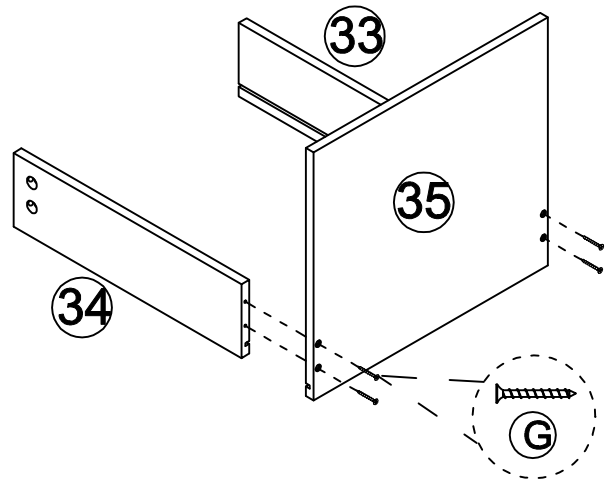
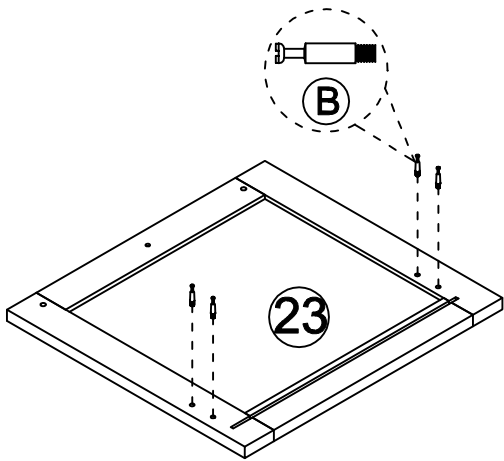
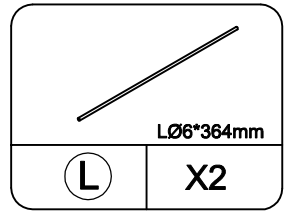
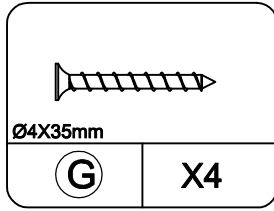
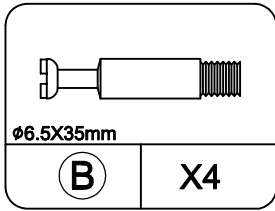
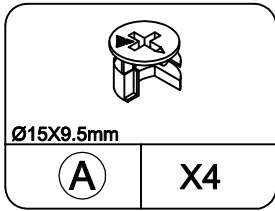
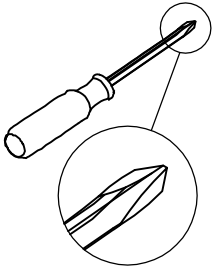

Proper orientation of CAM LOCK

# STEP 3

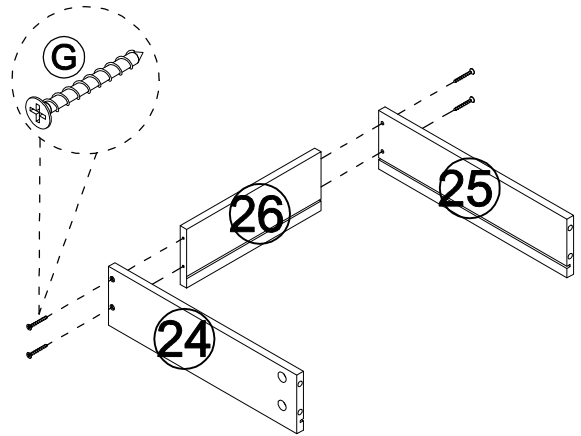
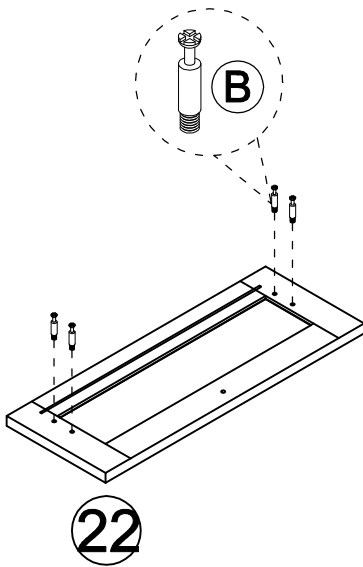
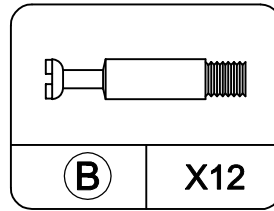
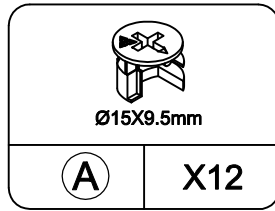
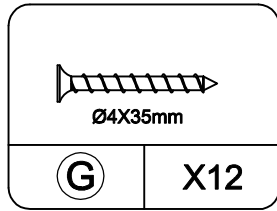
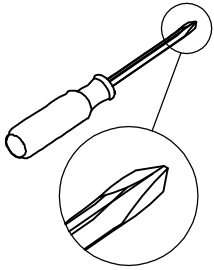

X 3

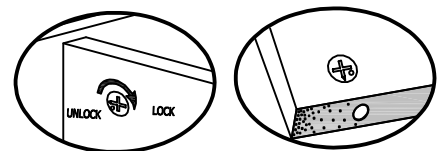
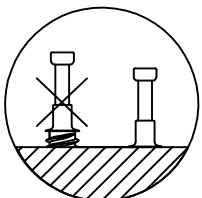
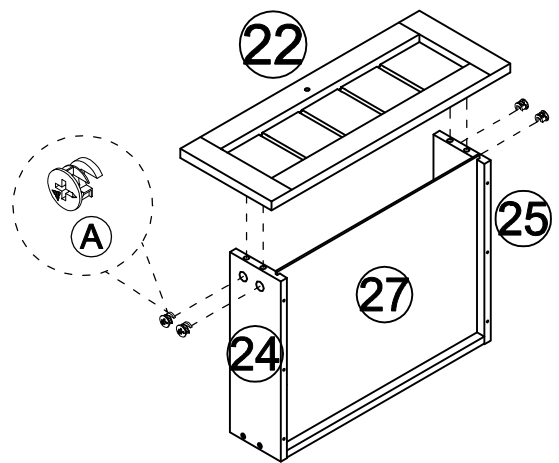
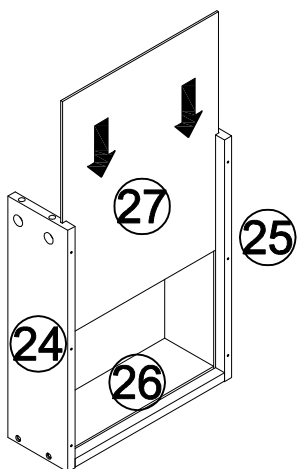

Proper orientation of CAM LOCK

# STEP4

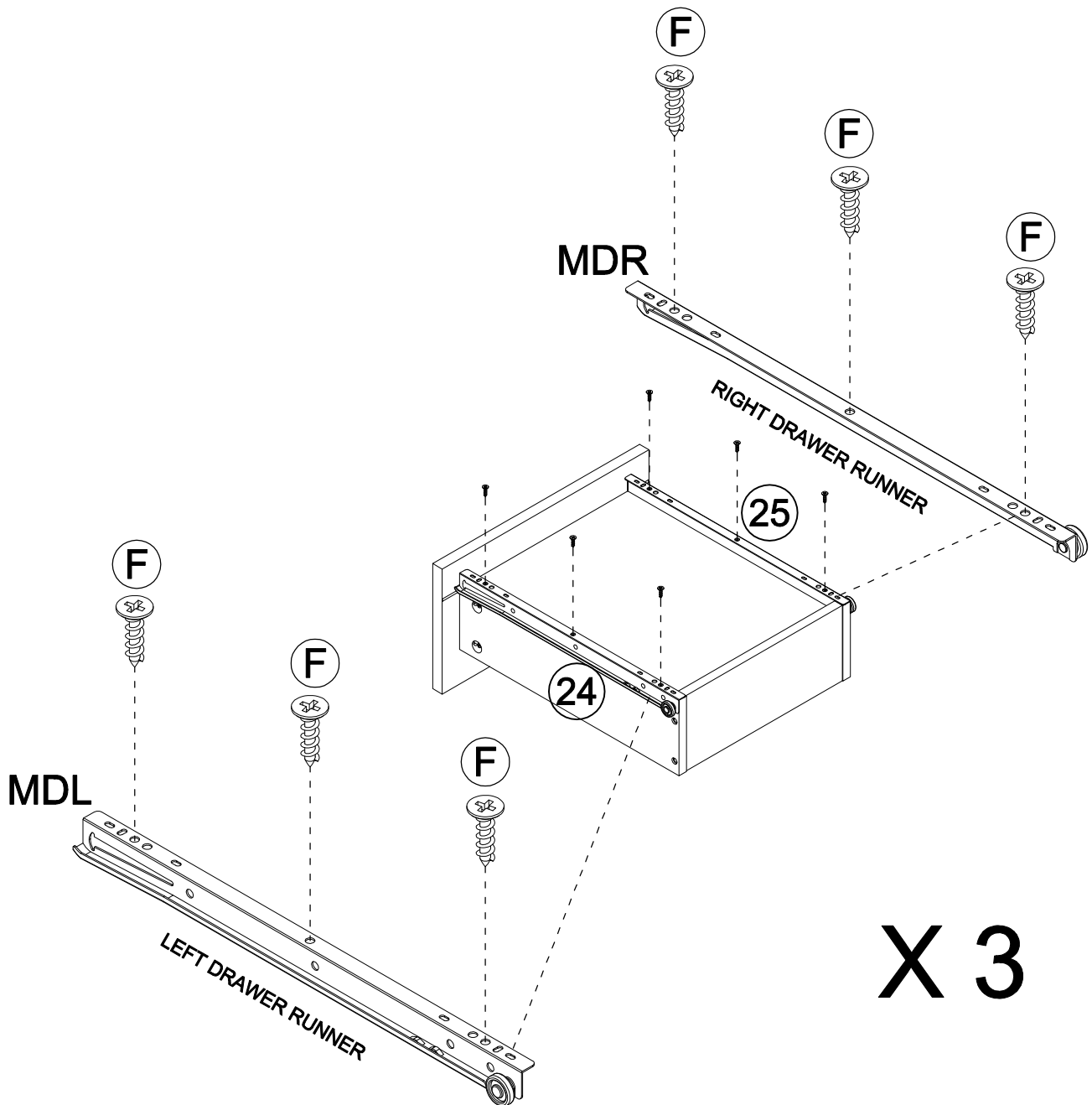
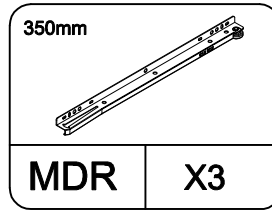
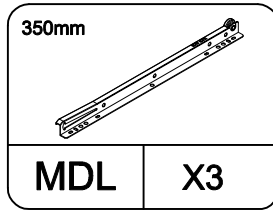
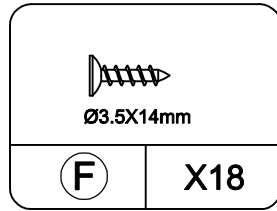
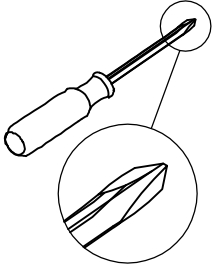

# STEP5

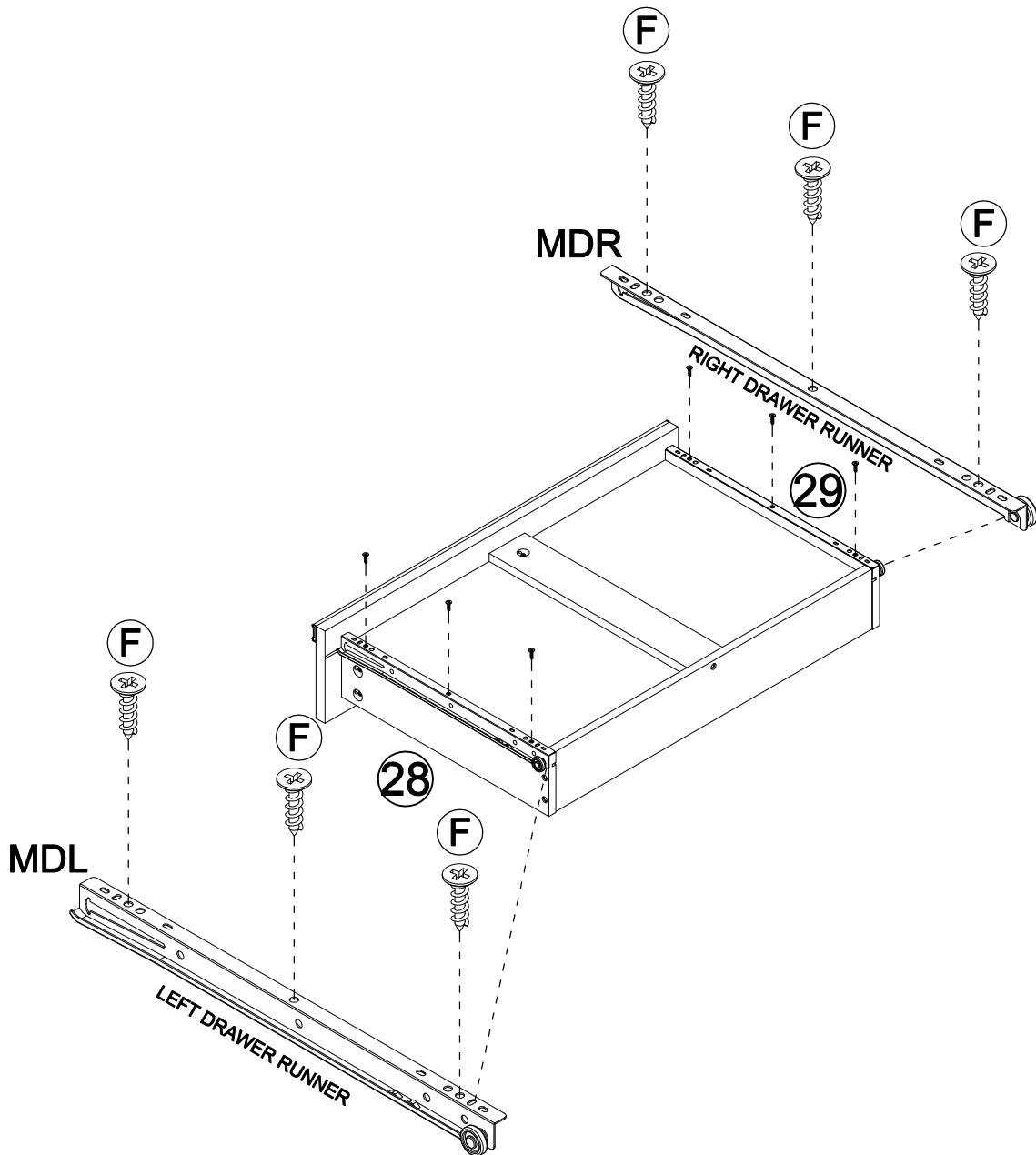
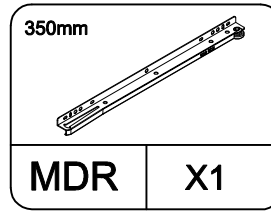
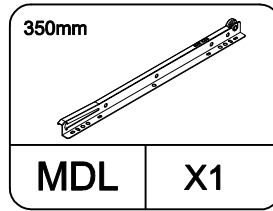
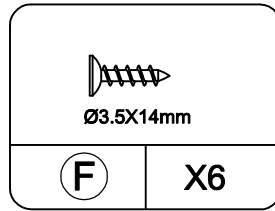
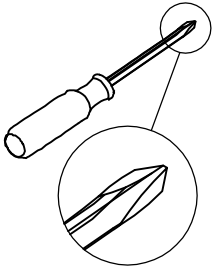

# STEP 6

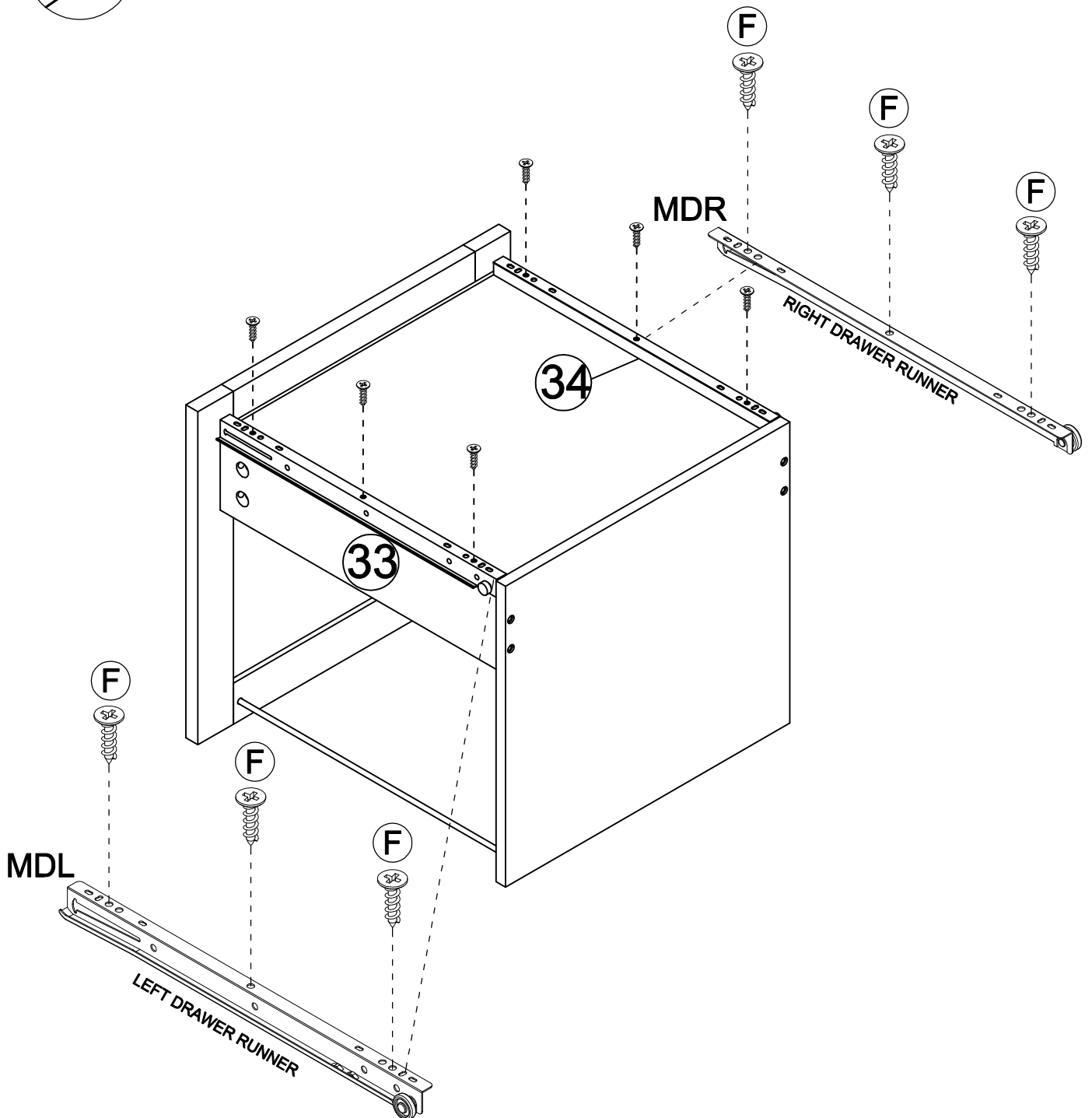
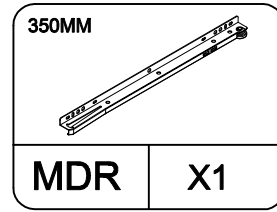
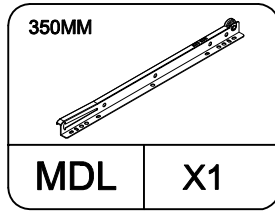
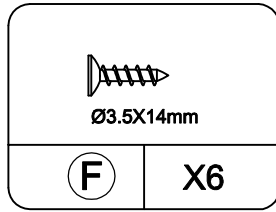
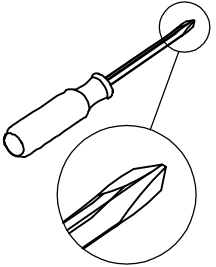

# STEP 7

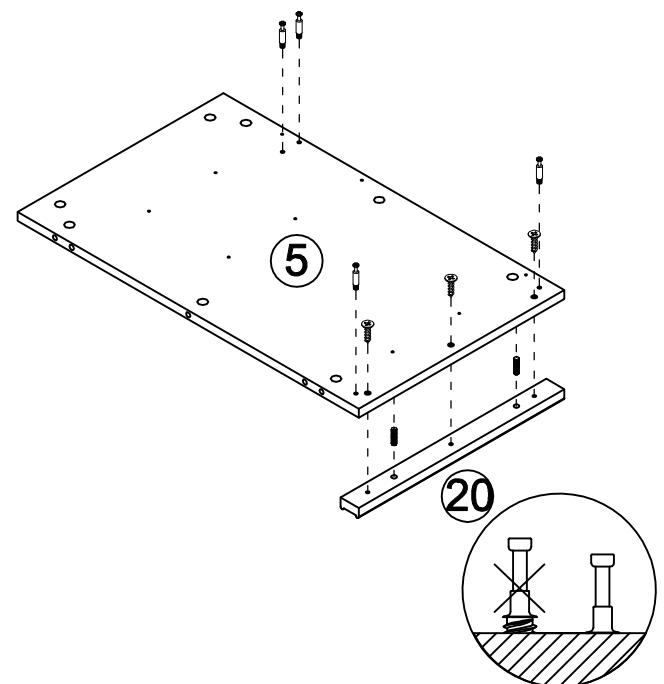
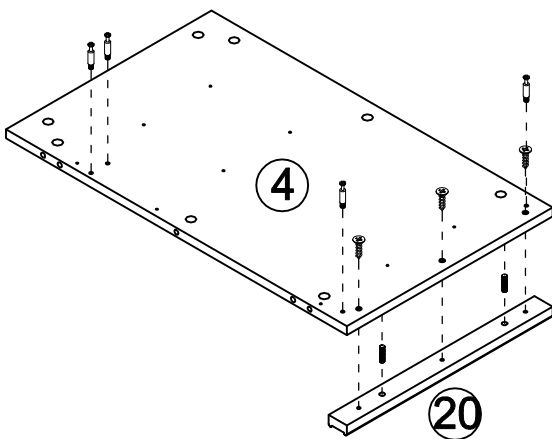
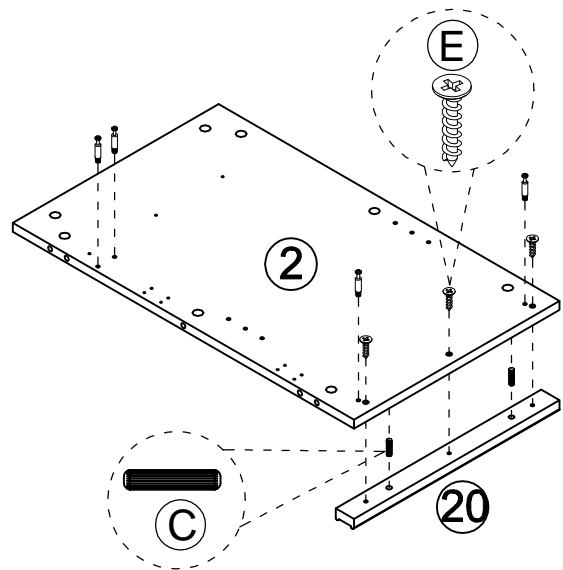
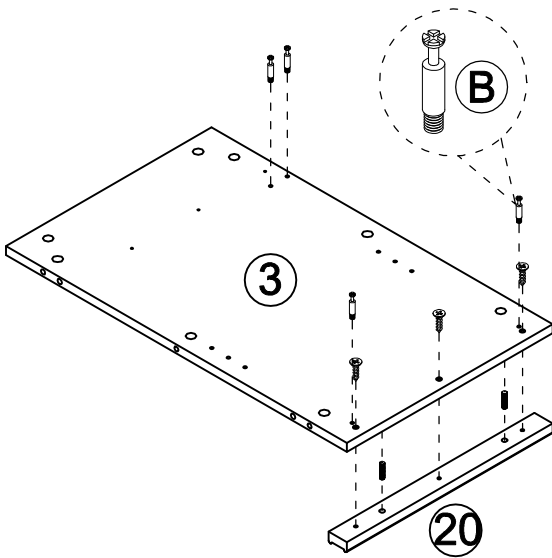
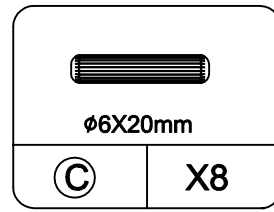
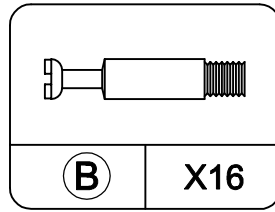
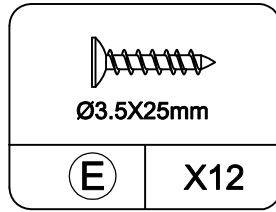
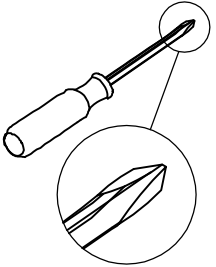

# STEP 8

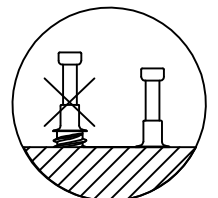
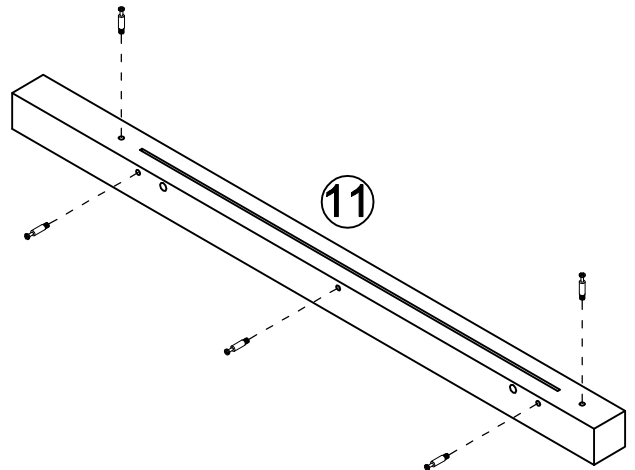
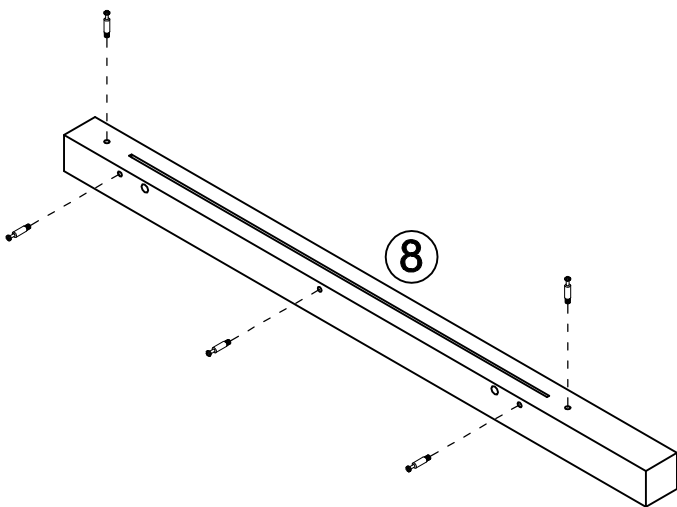
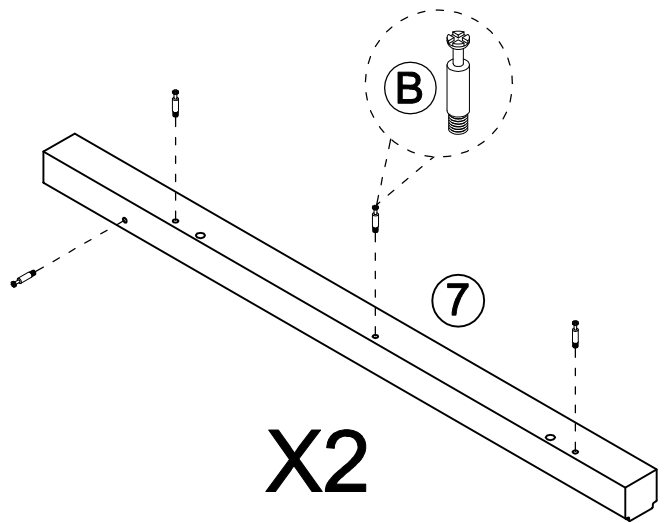
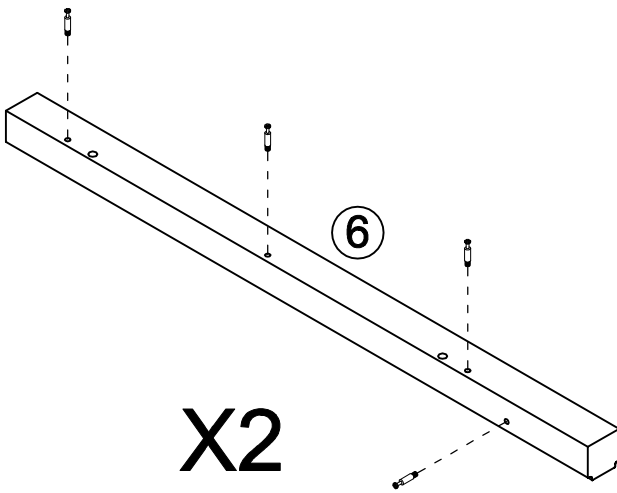
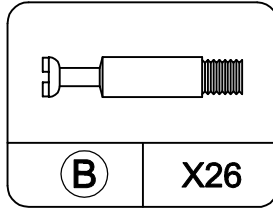
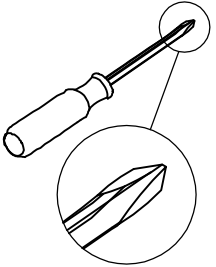

# STEP 9

---

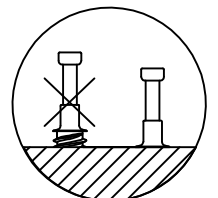
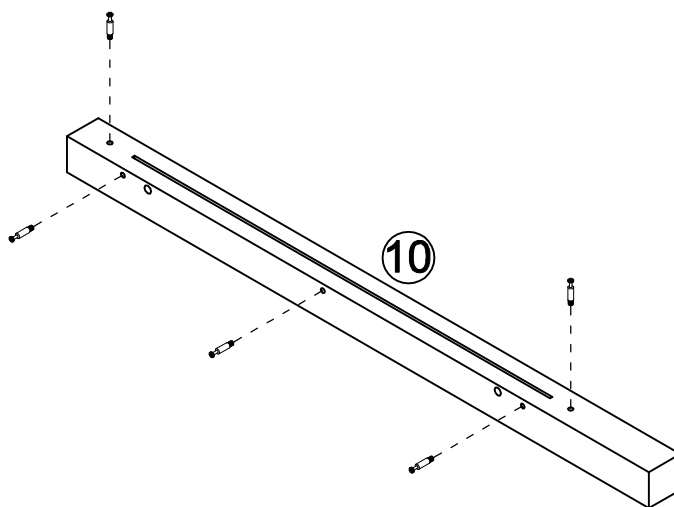
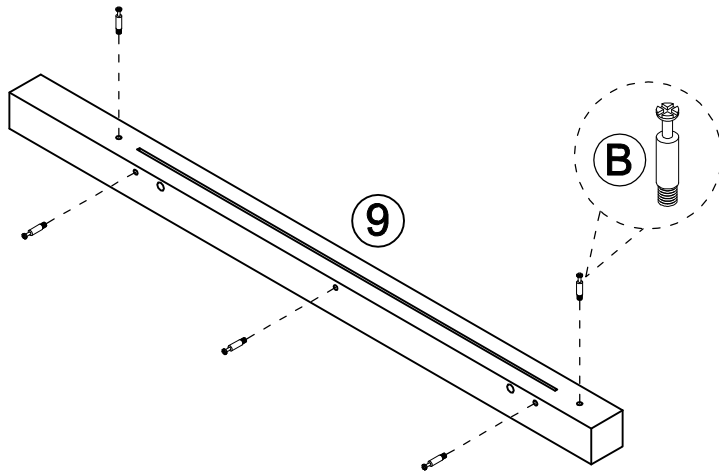
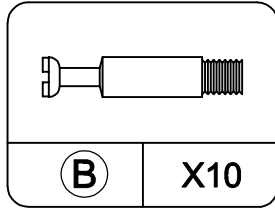
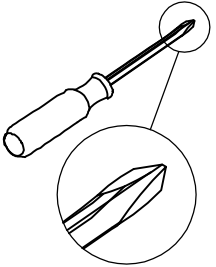

# STEP 10

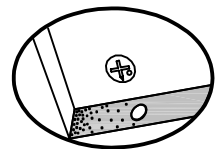
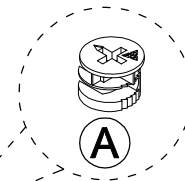
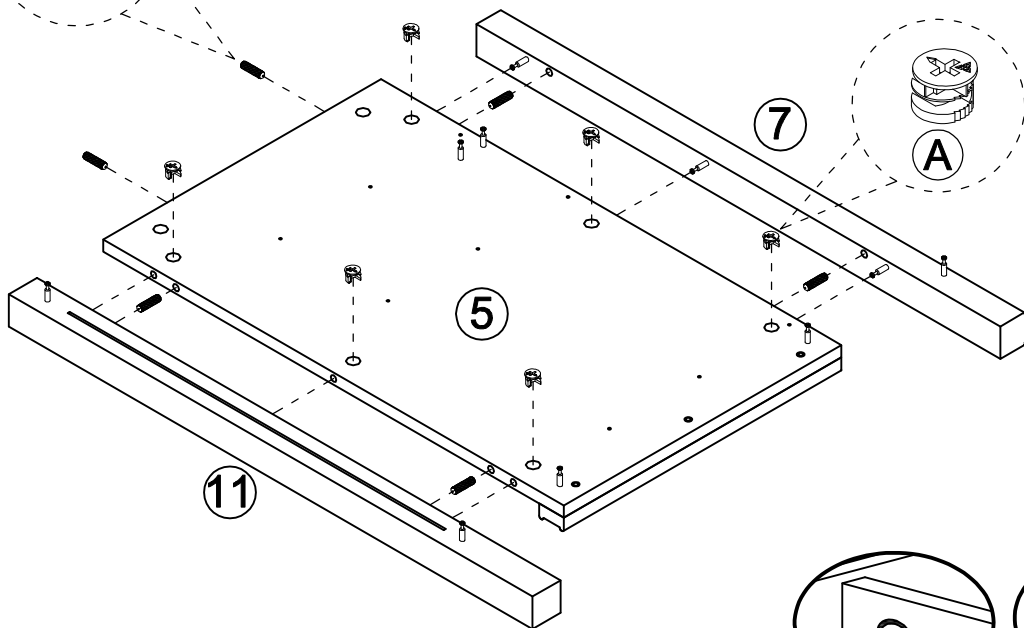
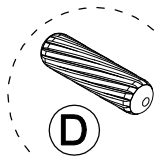
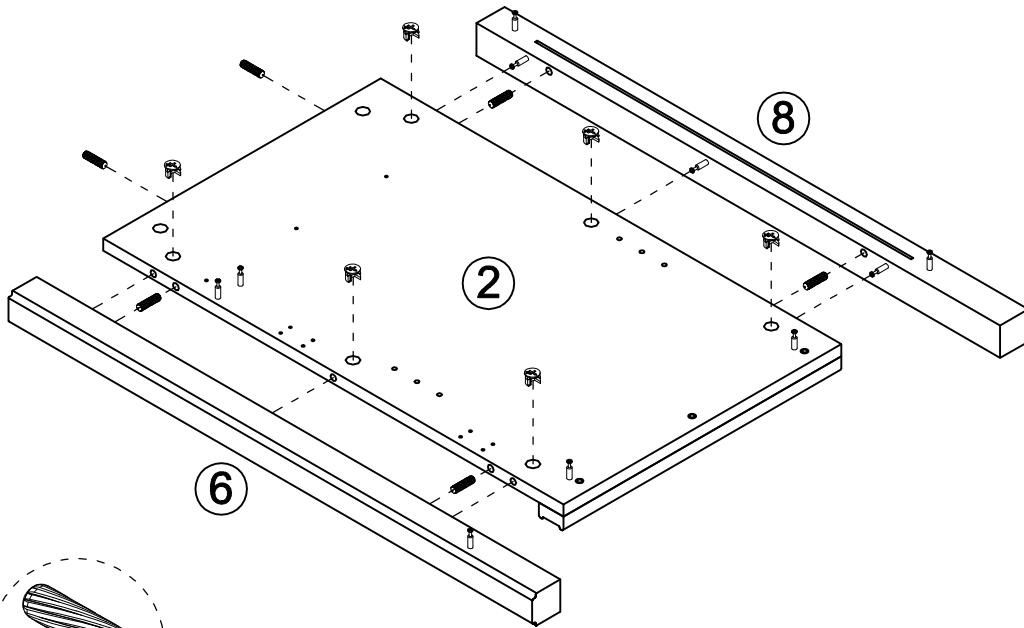
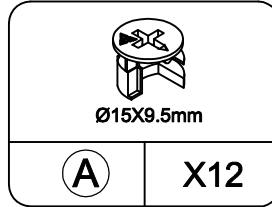
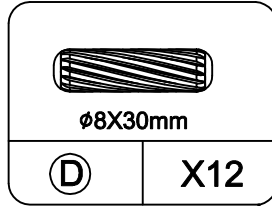
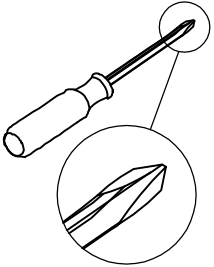

Proper orientation of CAM LOCK

# STEP 11

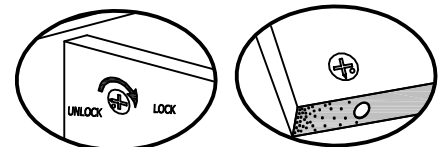
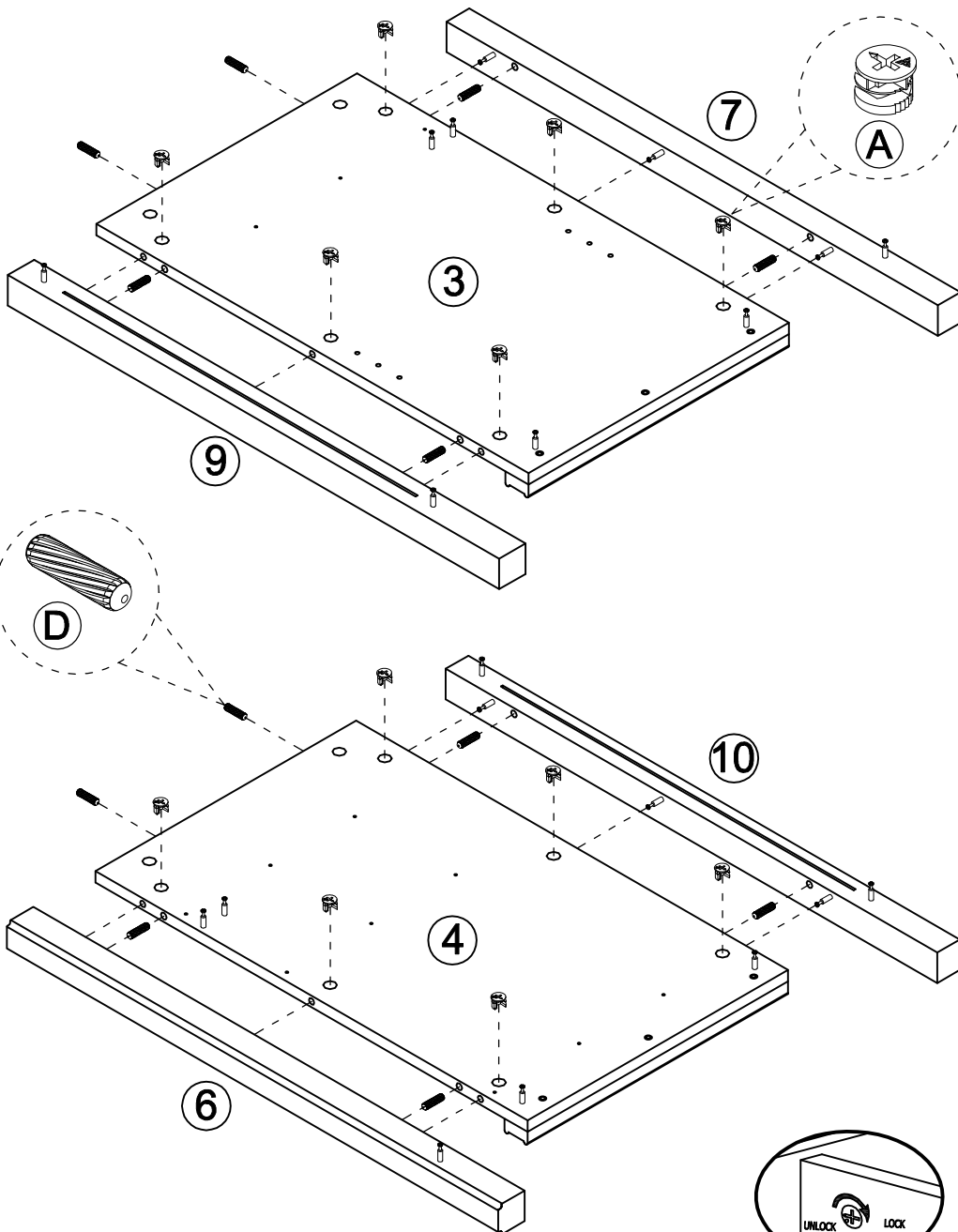
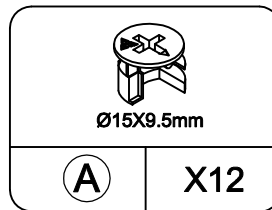
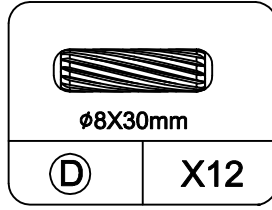
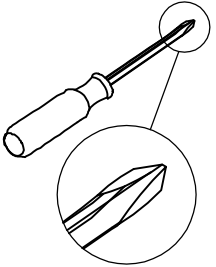

Proper orientation of CAM LOCK

# STEP 12

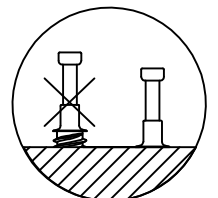
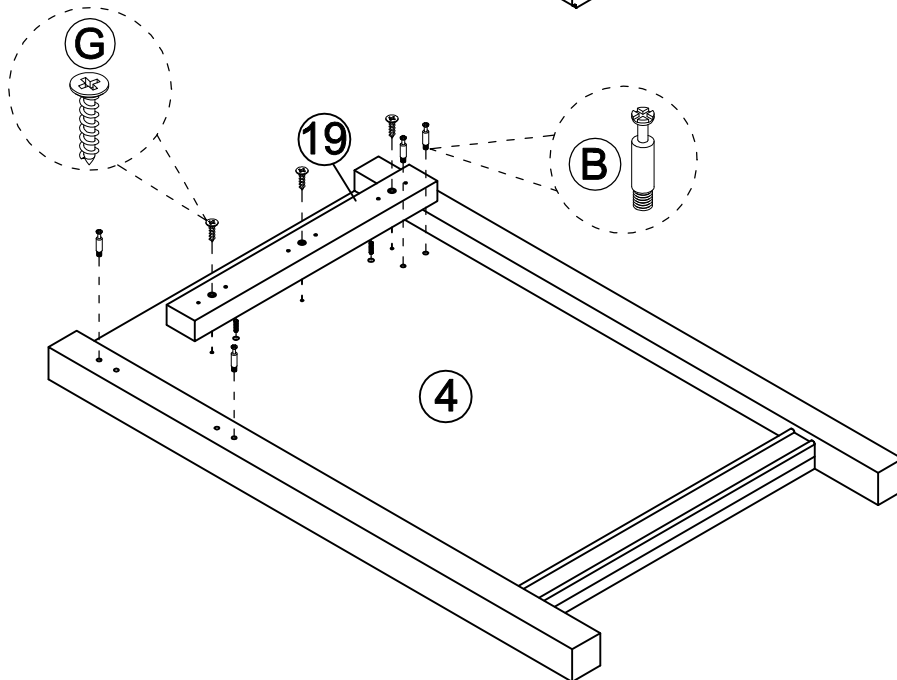
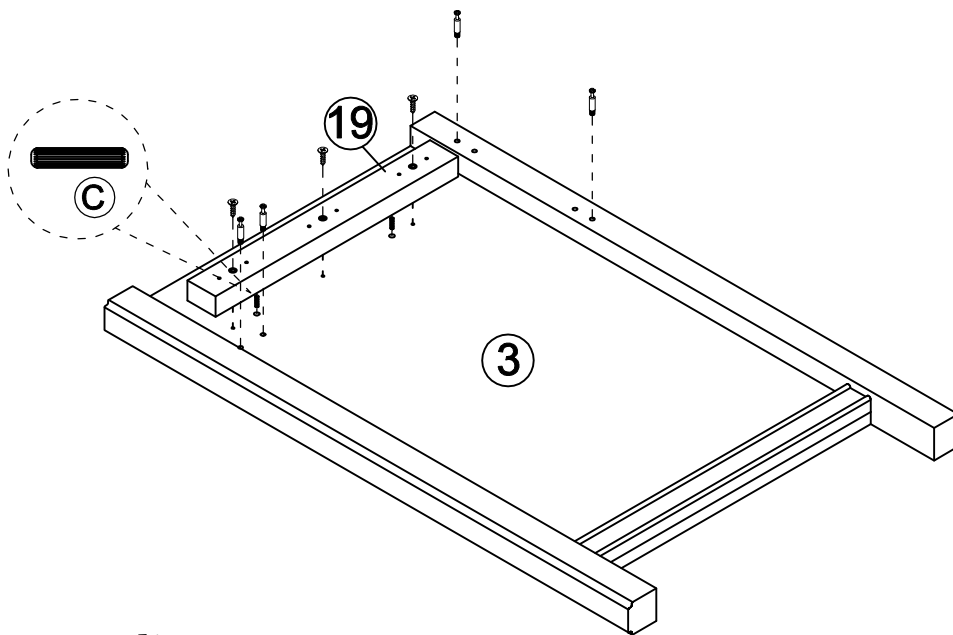
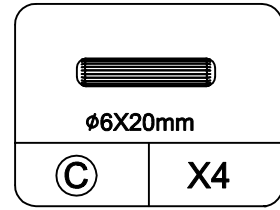
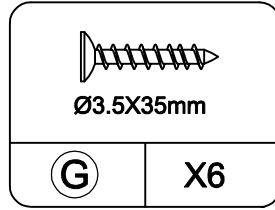
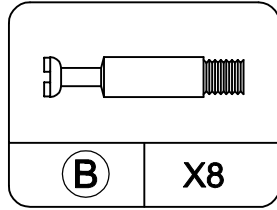
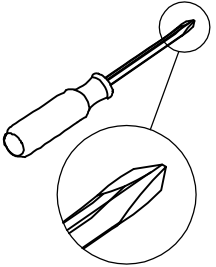

# STEP 13

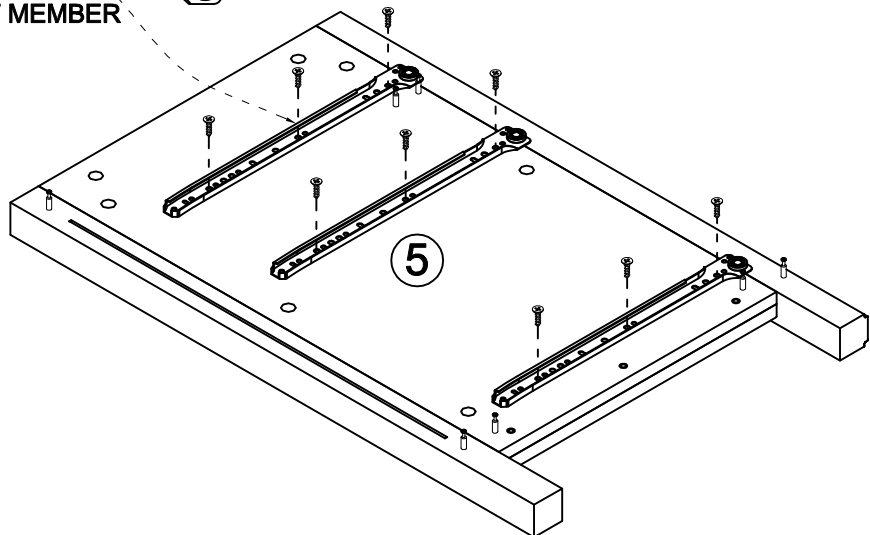
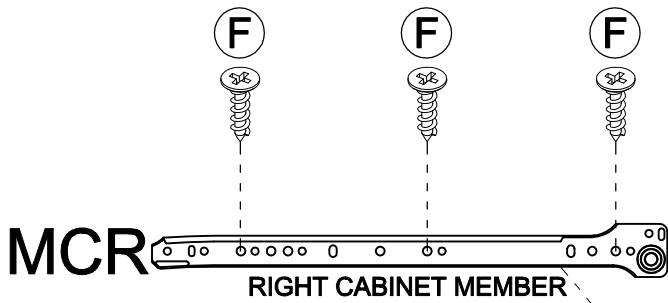
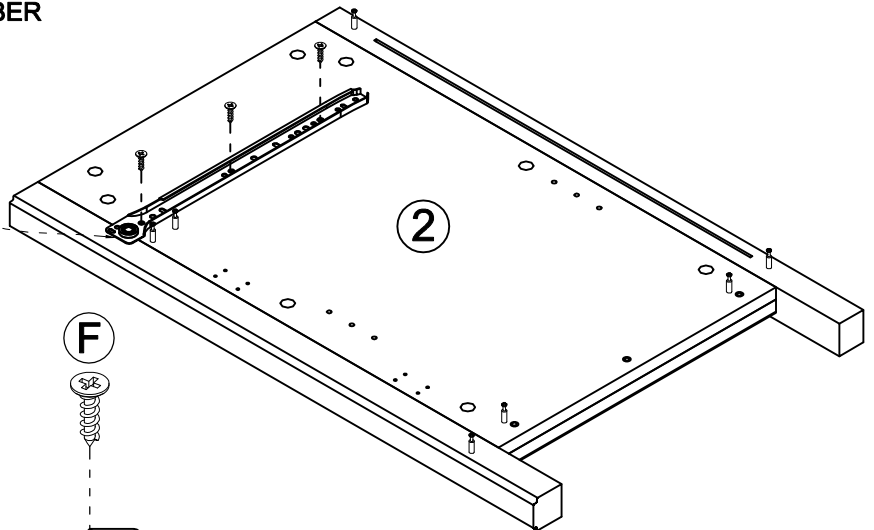
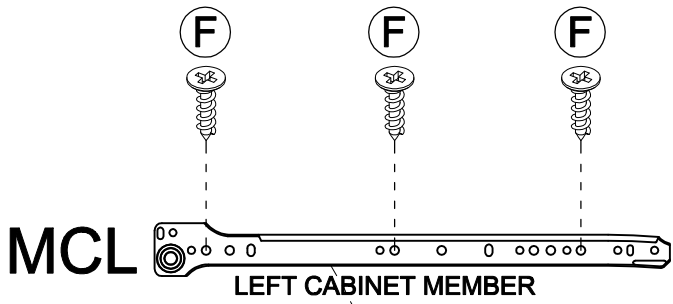
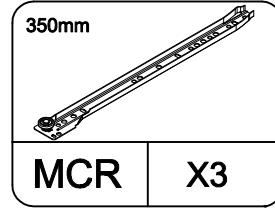
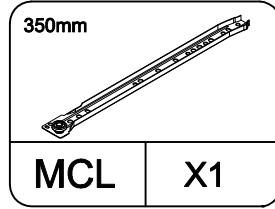
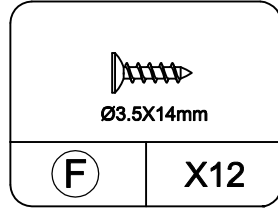
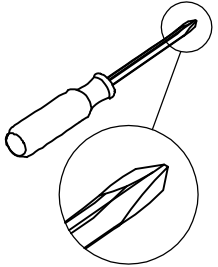

# STEP 14

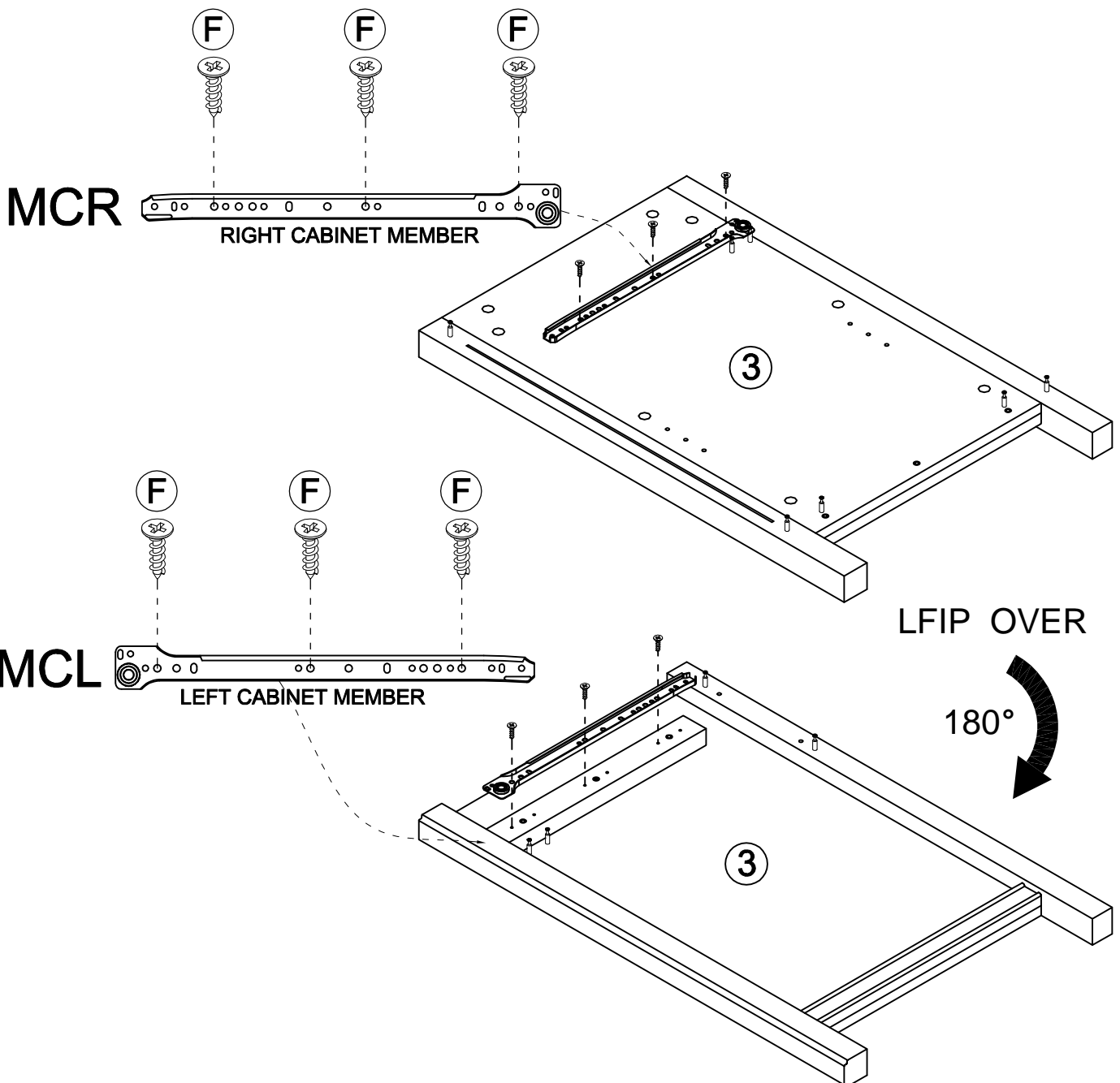
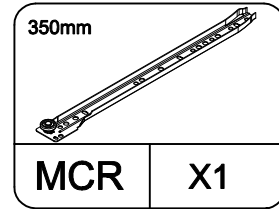
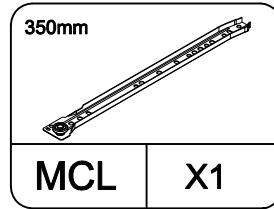
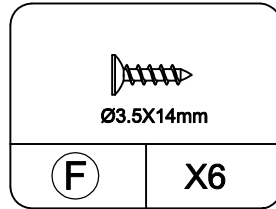
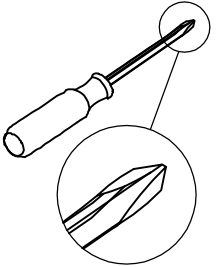

# STEP 15

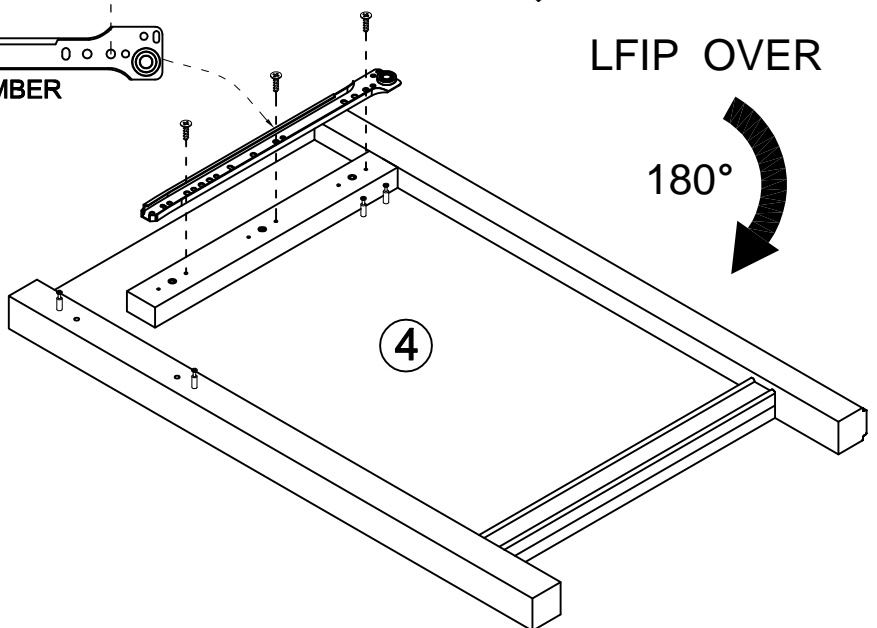
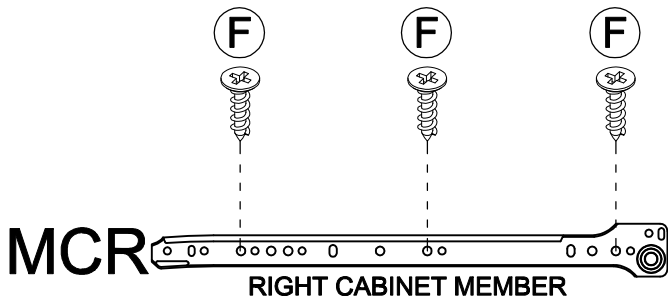
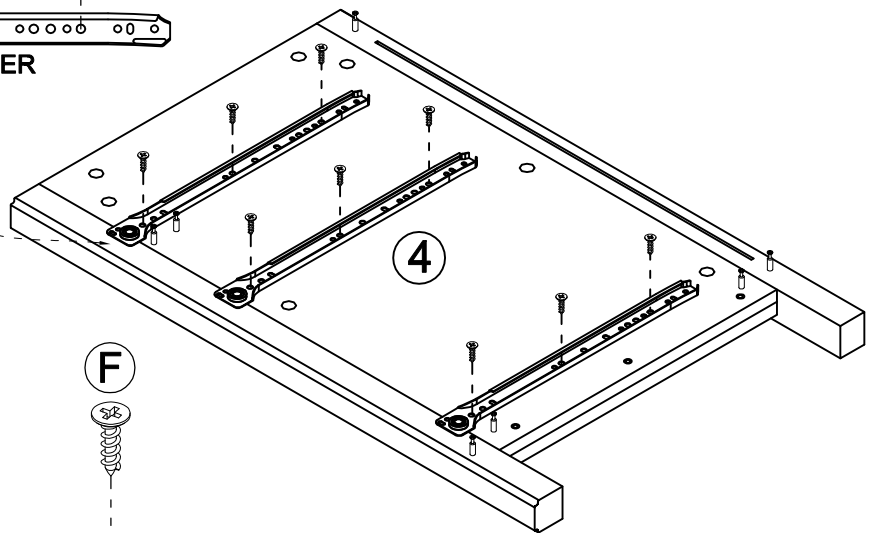
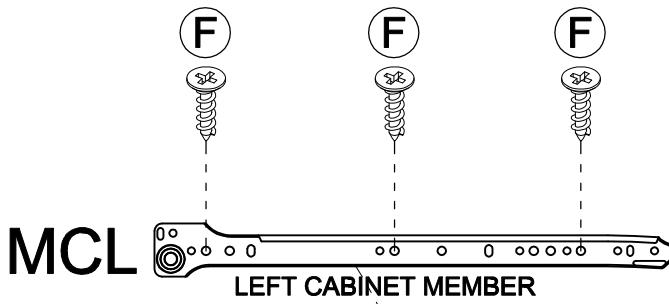
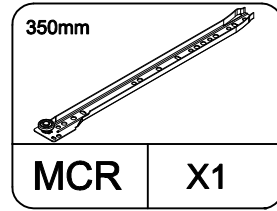
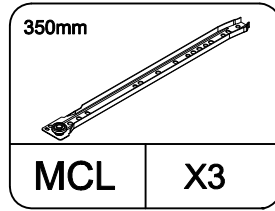
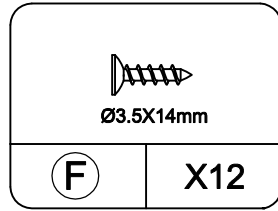
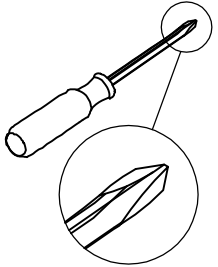

# STEP 16

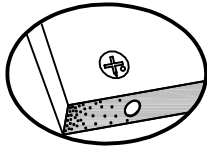
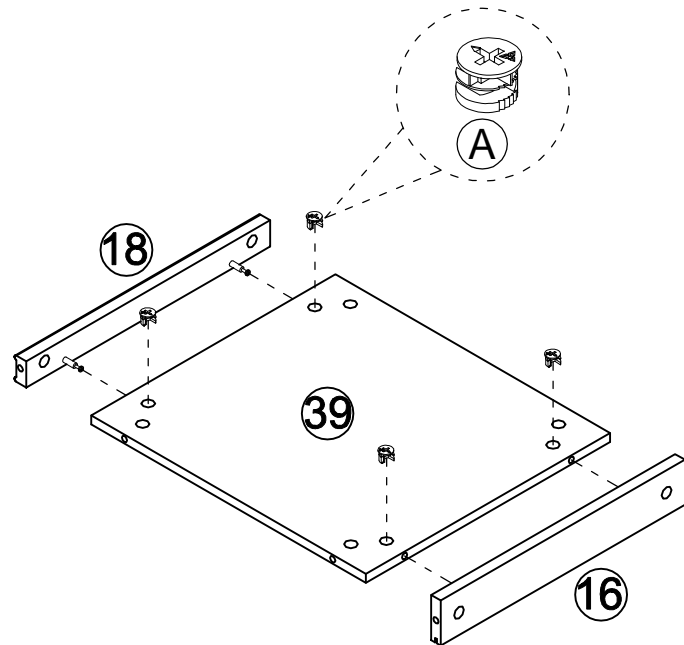
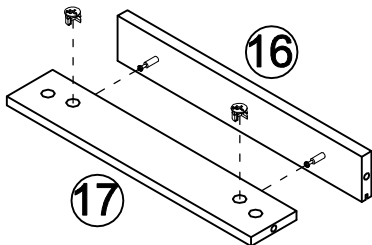
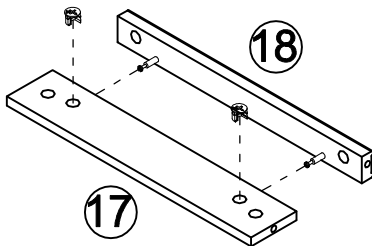
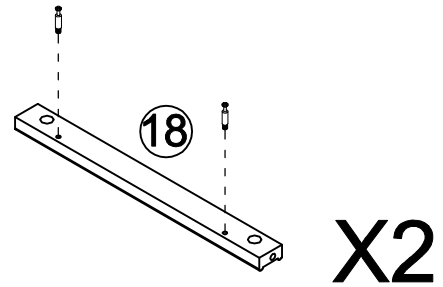
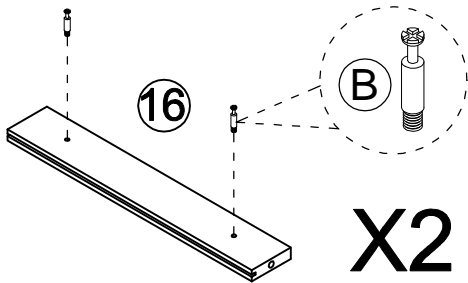
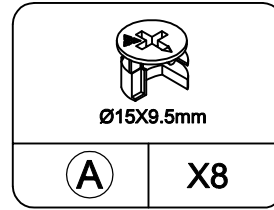
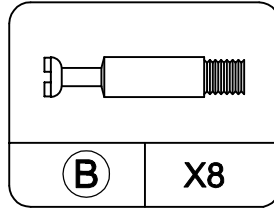
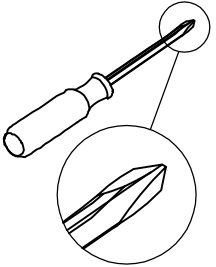

Proper orientation of CAM LOCK

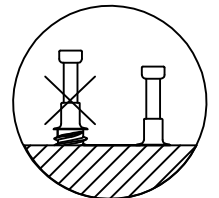

# STEP 17

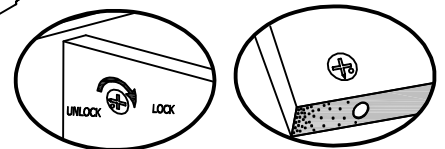
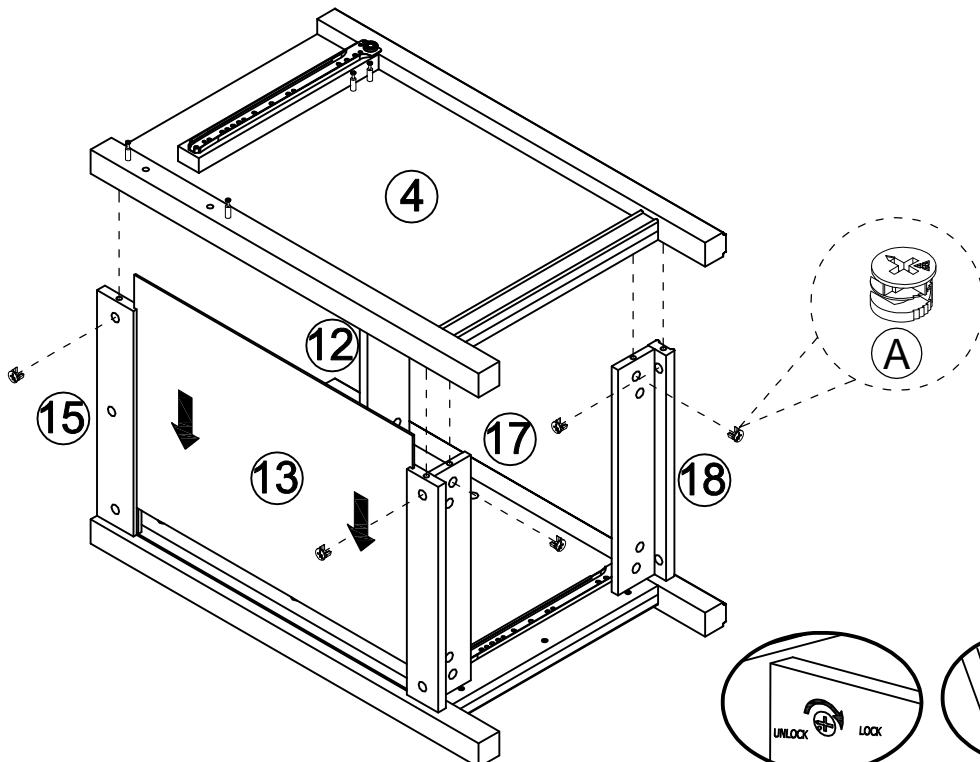
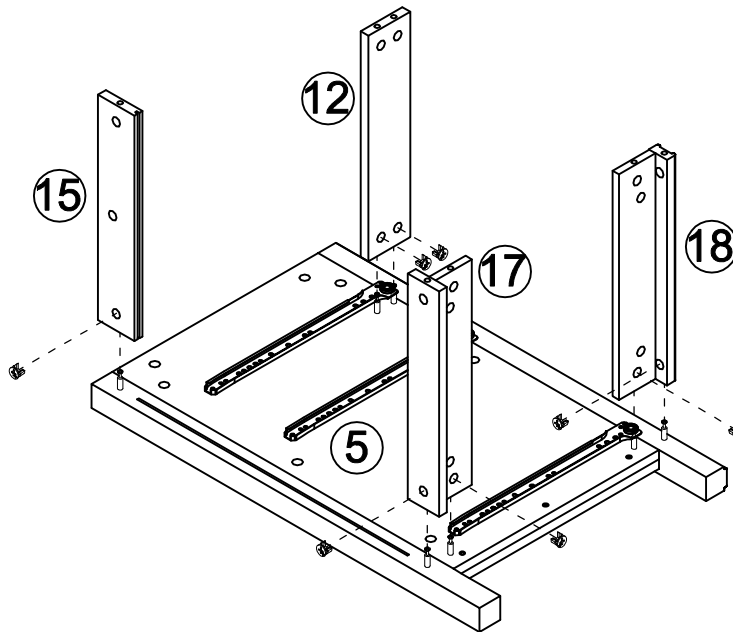
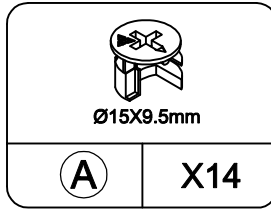
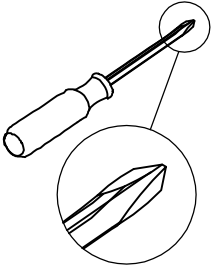

Proper orientation of CAM LOCK

# STEP 18

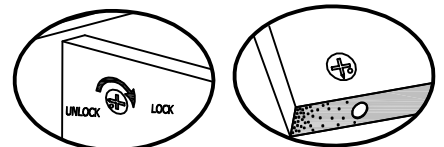
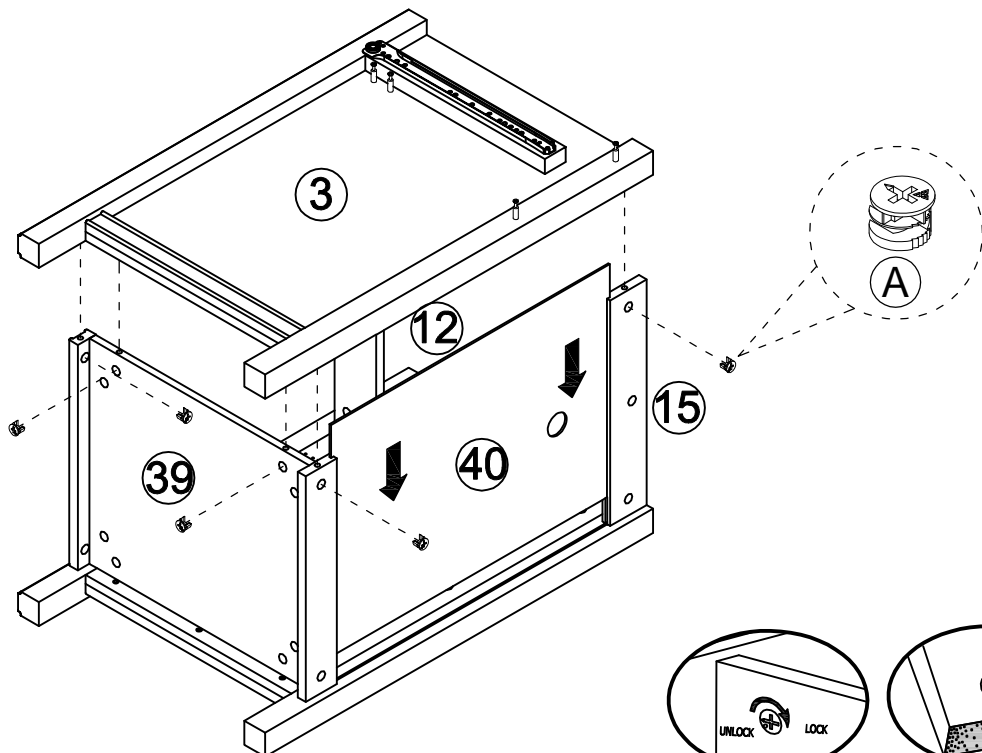
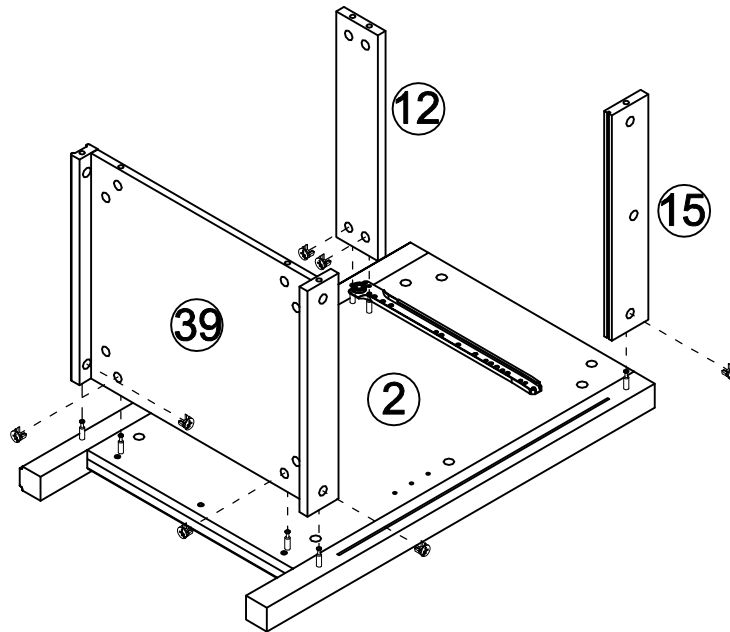
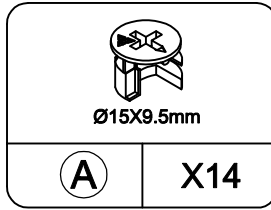
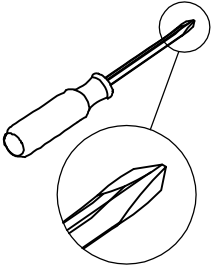

Proper orientation of CAM LOCK

# STEP 19

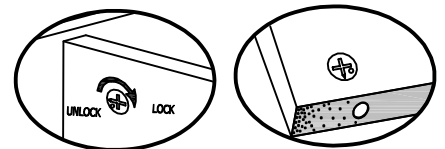
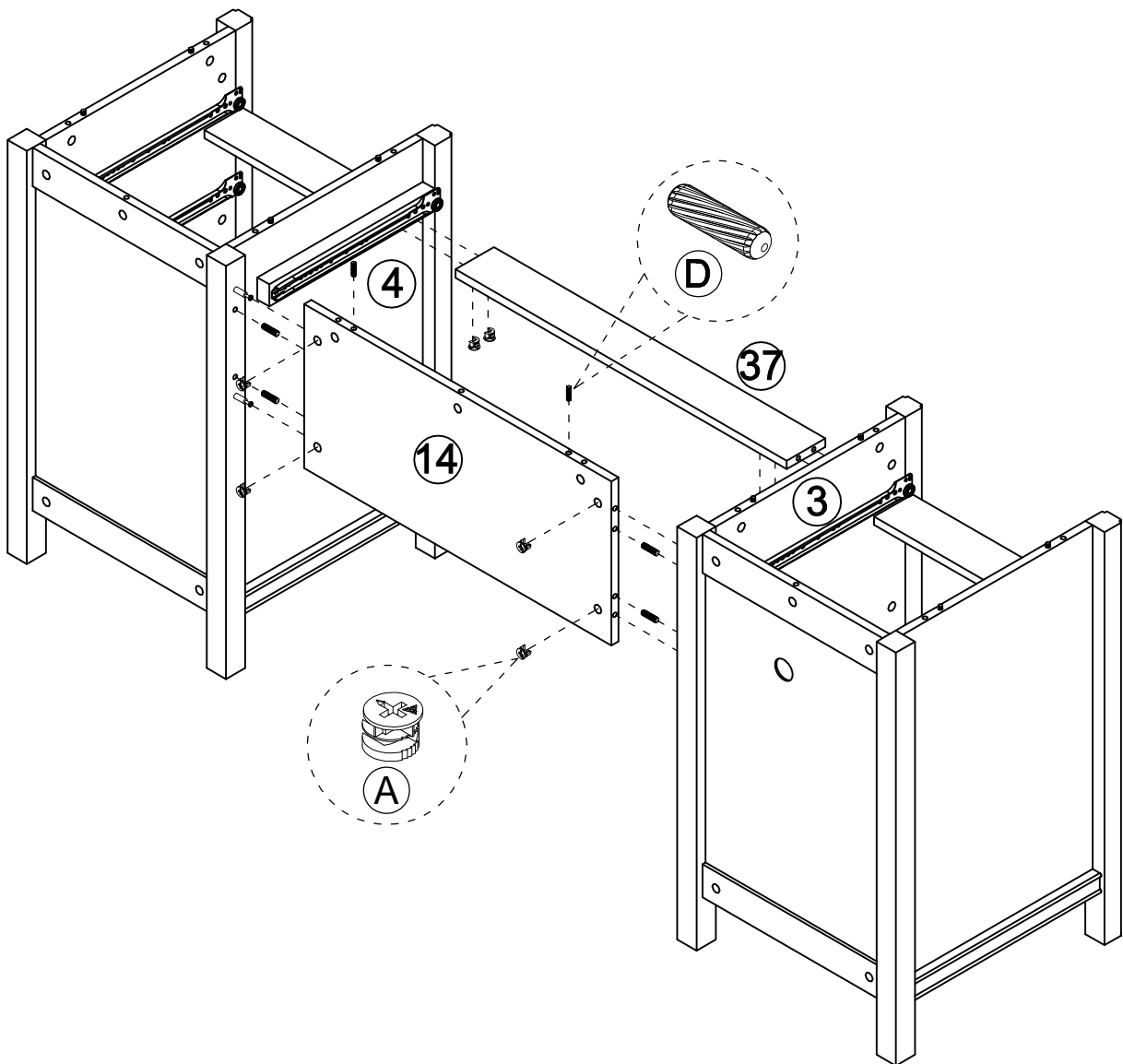
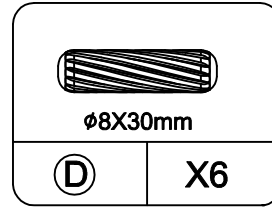
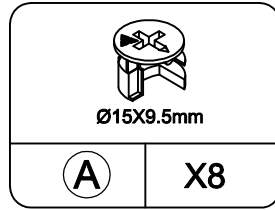
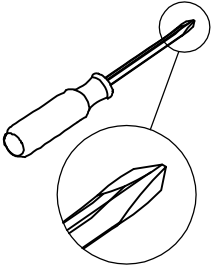

Proper orientation of CAM LOCK

# STEP 20

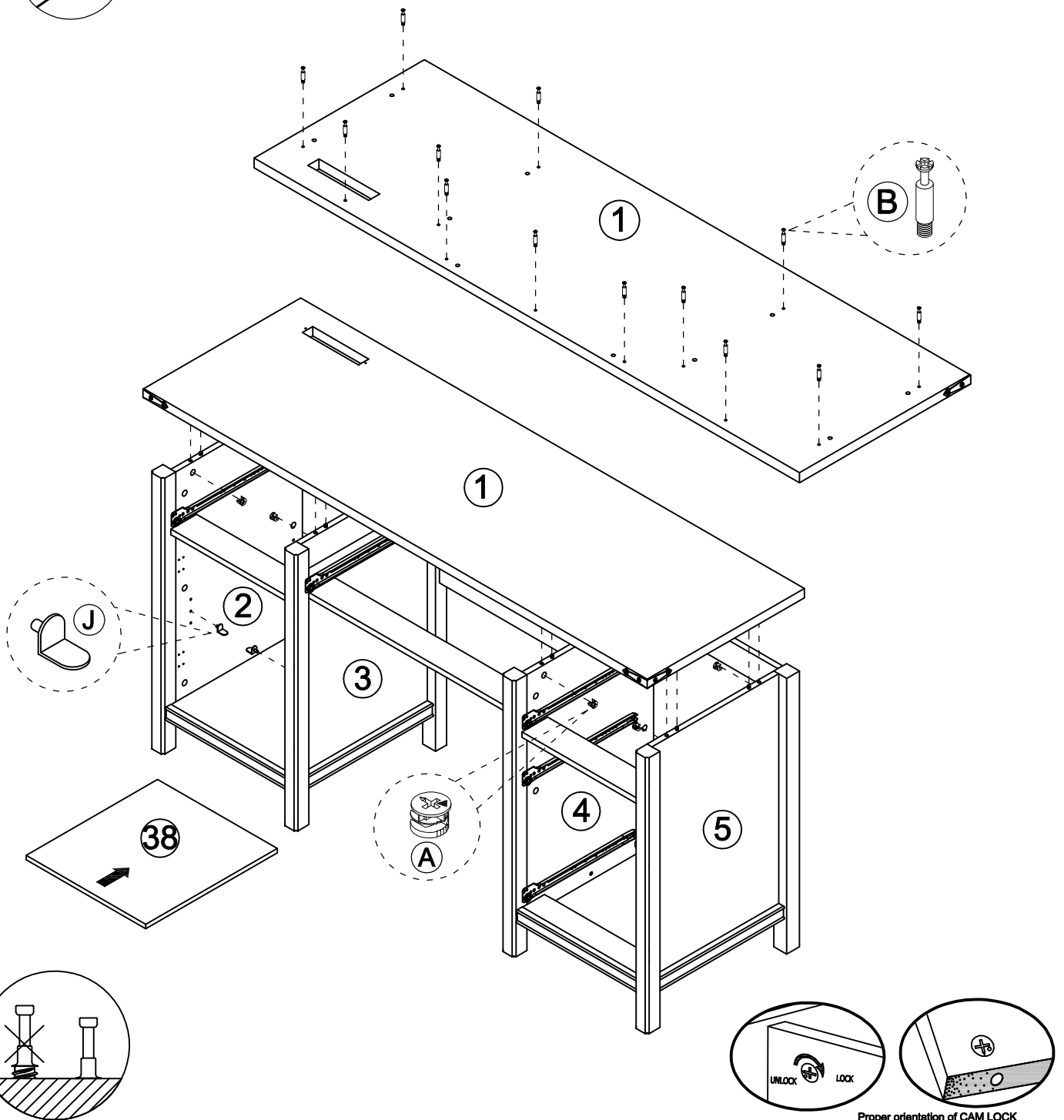
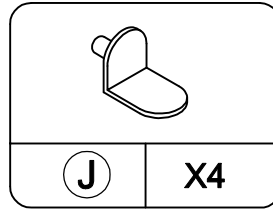
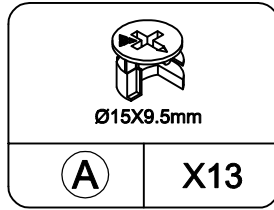
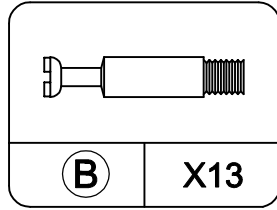
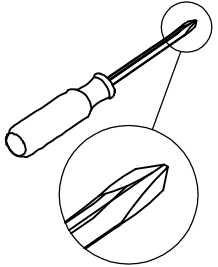

# STEP 21

---

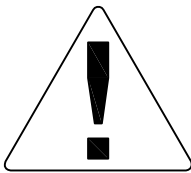
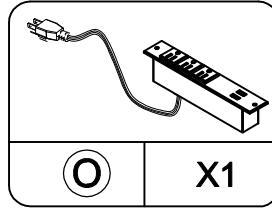
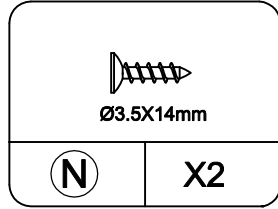
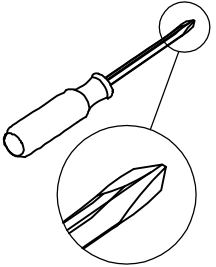

The power of using electrical appliances cannot exceed 1500W

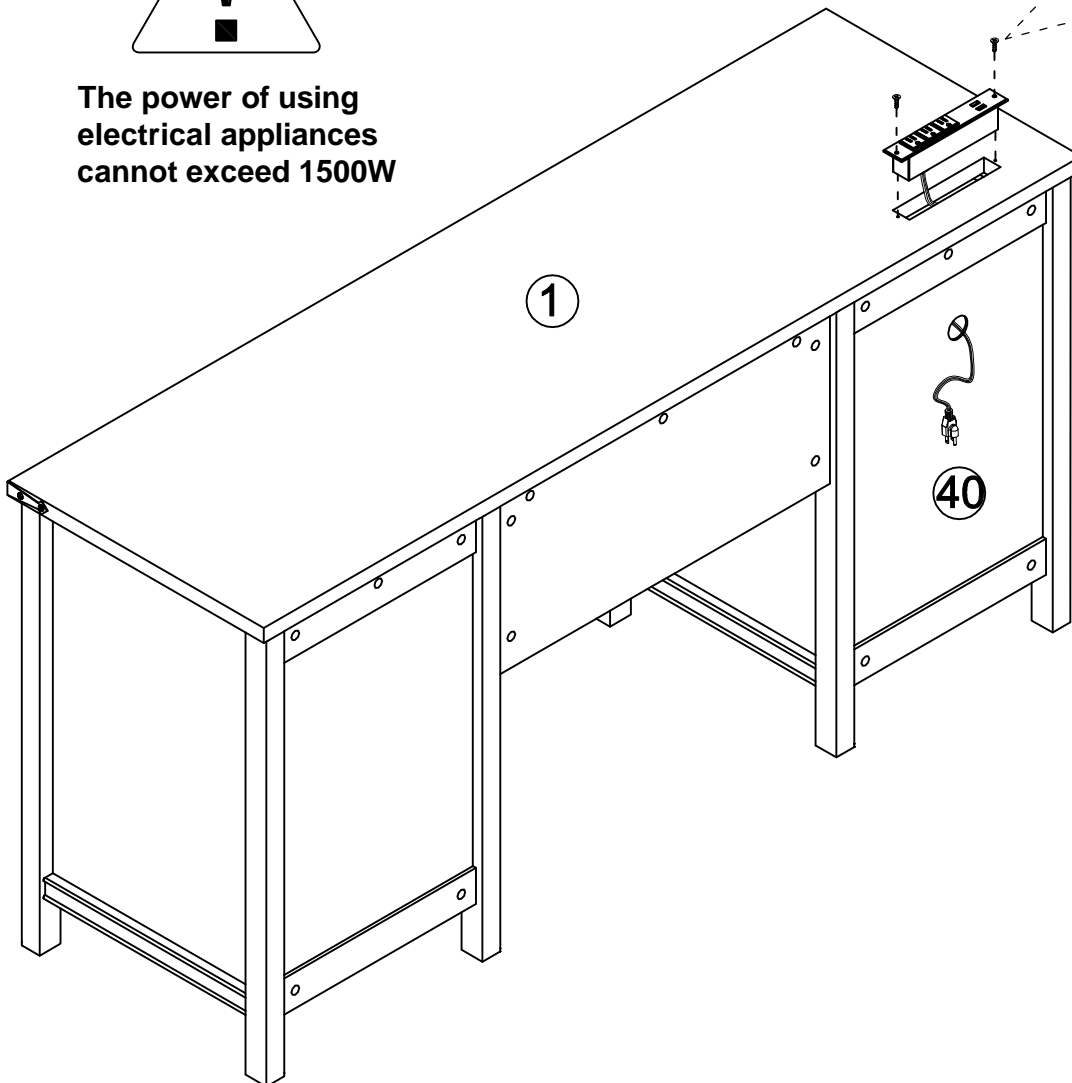
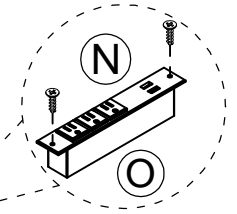

# STEP 22

---

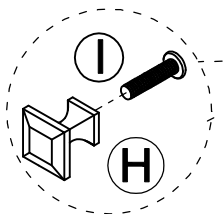
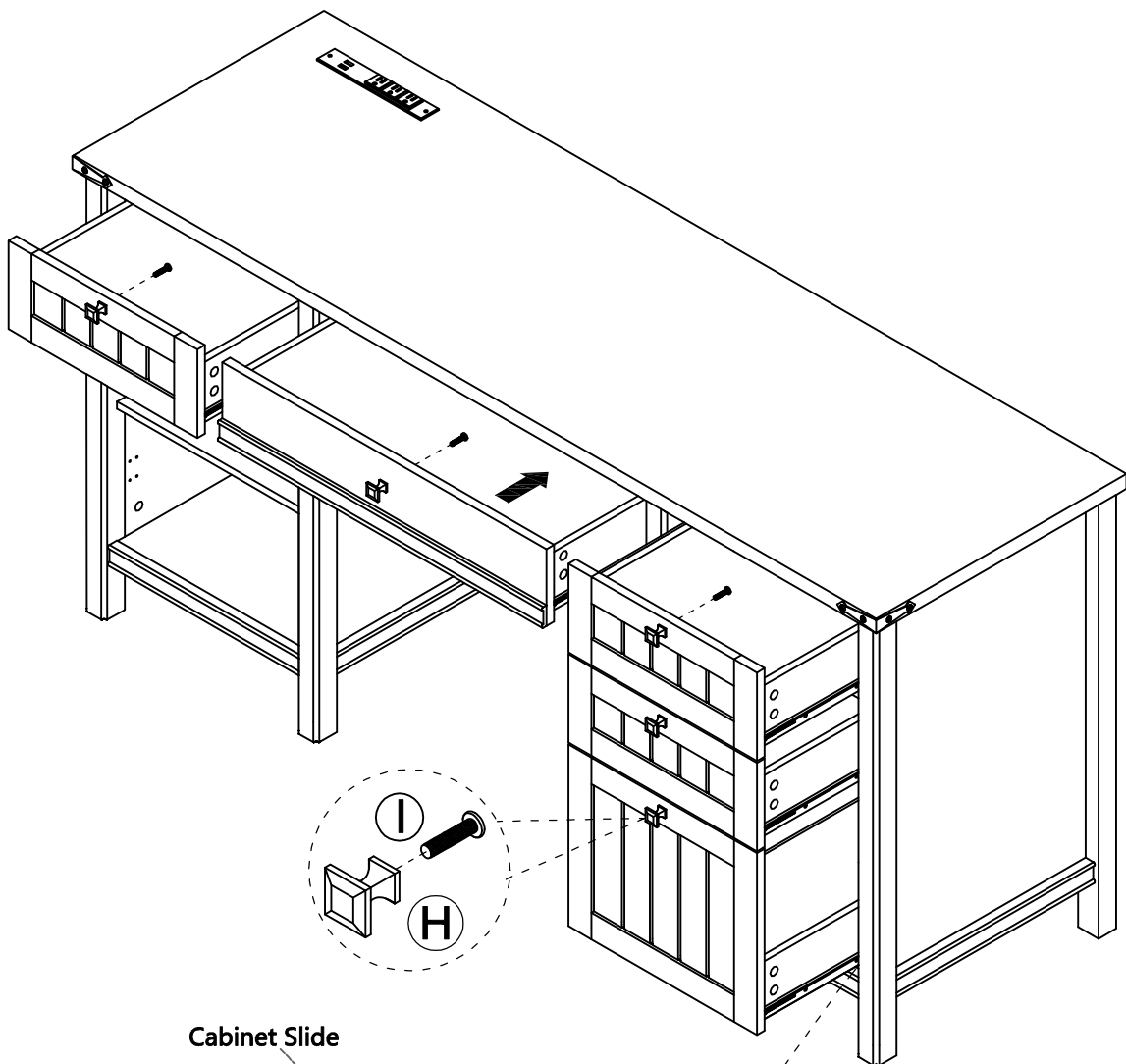
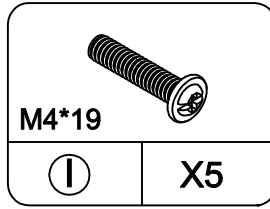
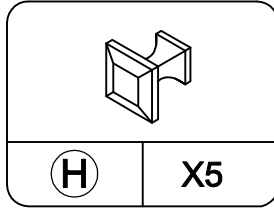
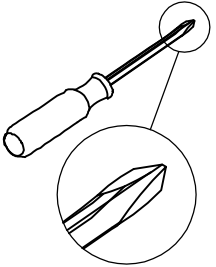

Cabinet Slide

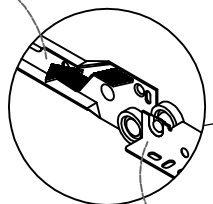

Drawer Slide

# STEP 23

