



NOTE:

This brochure contains IMPORTANT safety info. Please read and keep for future reference.

MAINTAINANCE AND WARNING

- 1.Keep furniture away from heat sources.
- 2.Do not clean furniture with harsh cleaner or polishes.Do not use detergents,solvents,abrasives,spray packs or leather cleaner. Use non-color mild soa with warm water to clean spills(Mix 1:10 soap to water).
- 3.Do not place furniture under direct sunlight,material will possibly fade over time.
- 4.Do not use on site dry cleaning machine.Children should not climb or jump on the furniture.
- 5.Do not write on furniture that is not protectedby a padded barrier.
- 6.Not for commercial use,only for residential use.



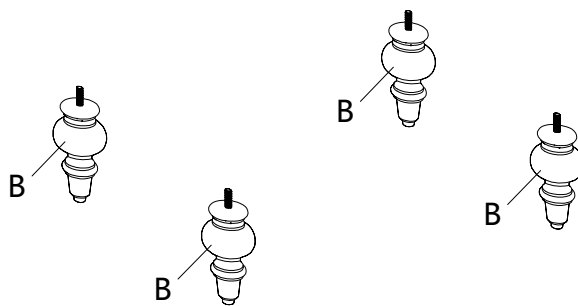
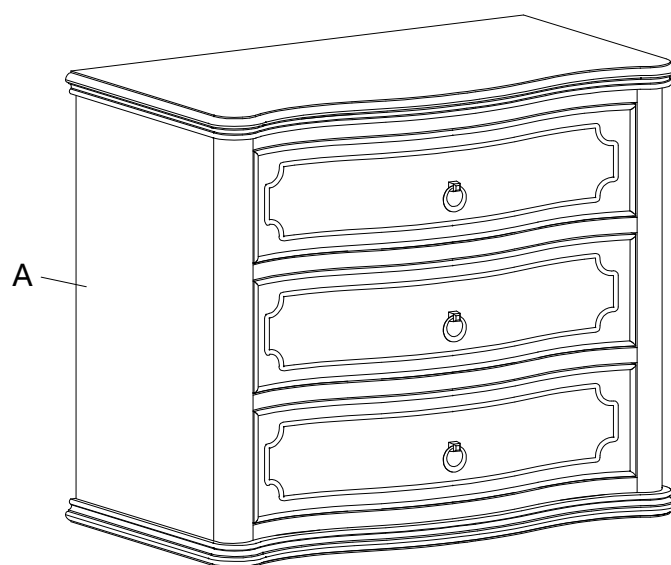

Weight Limitation
110 LBS

EXPLOSIVE VIEW



PARTS LIST

A	x1	B	x4
			

HARDWARE LIST

#1	x2
	

TOOL LIST

#2	x1
	

ASSEMBLY INSTRUCTIONS

STEP-1

Screw the four leg(B) onto the base plate(A).

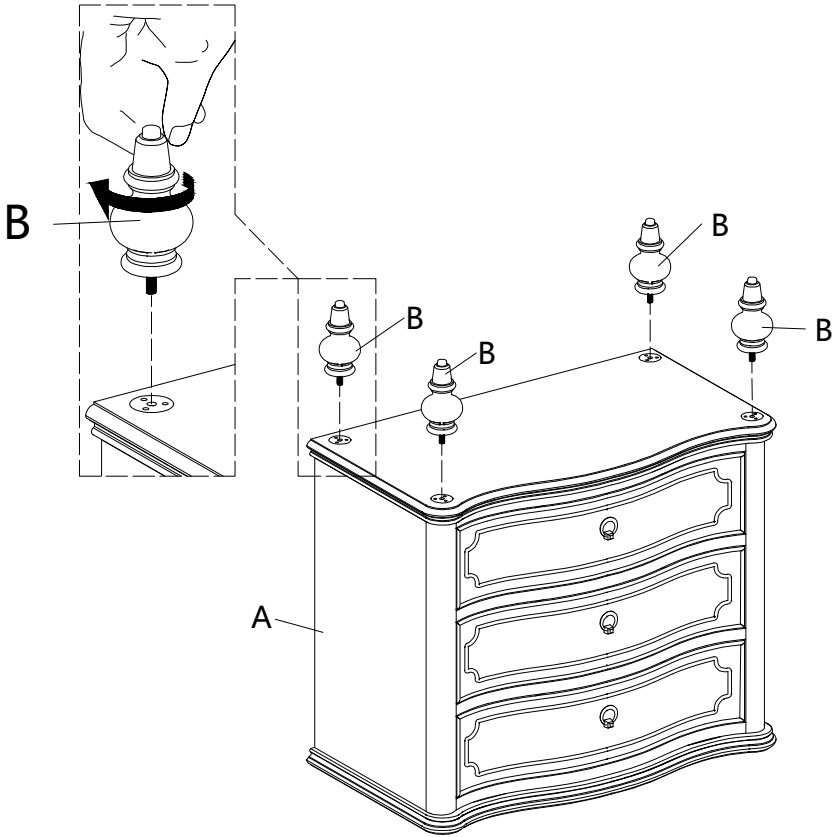

ASSEMBLY INSTRUCTIONS



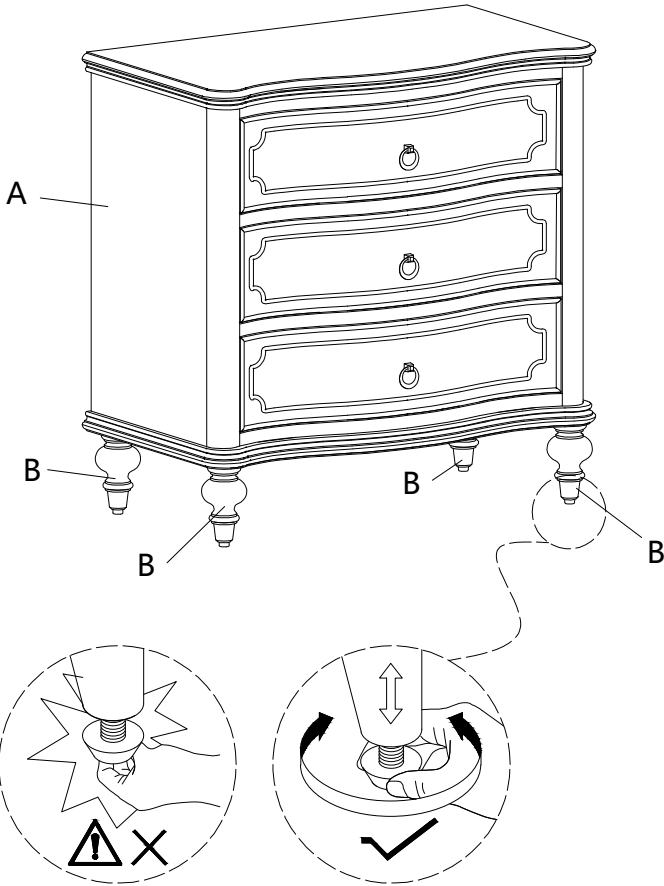
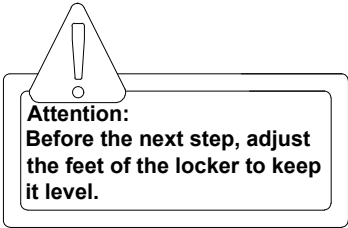

STEP-2

Attention:

Before the next step, adjust the feet of the locker to keep it level.

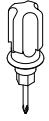

ASSEMBLY INSTRUCTIONS



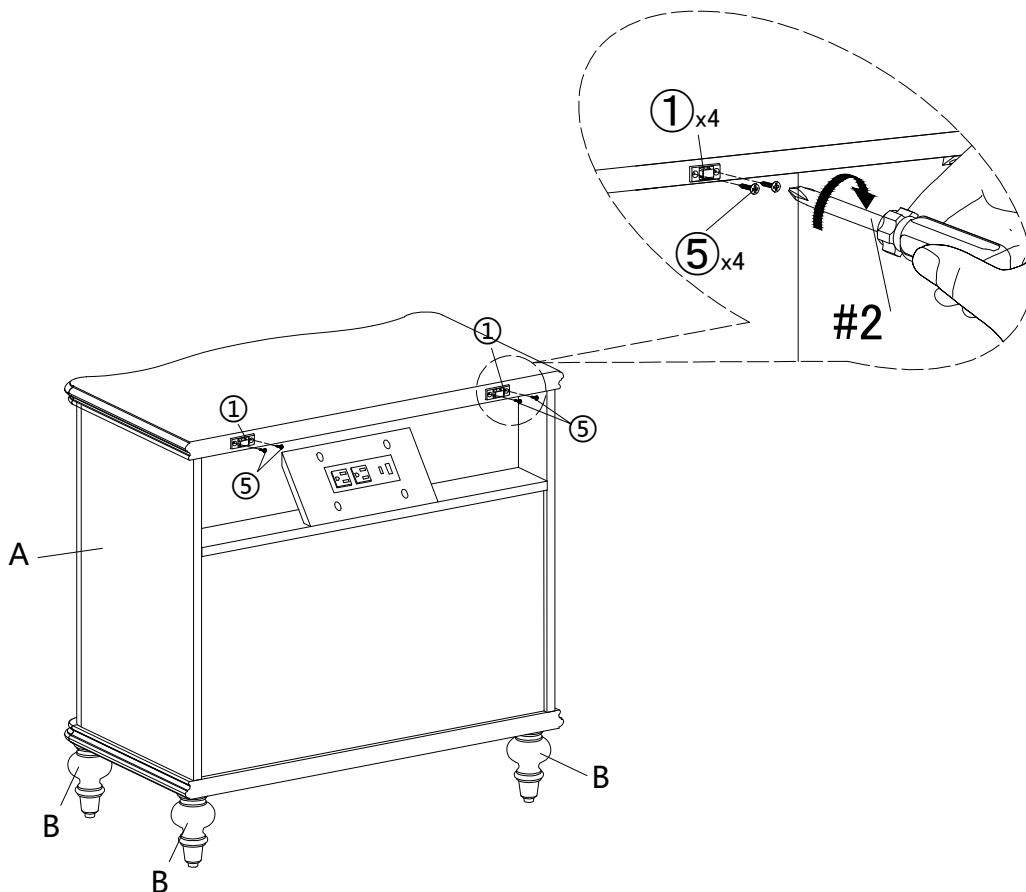

#2	x1	#1	x2	①	x2	⑤	x4
							

STEP-3

Use nylon packaging #1 Inside screw ⑤ to attach bracket ① to the corresponding hole of top panel(A), tighten screw with screwdriver #2.

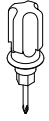

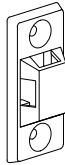
ASSEMBLY INSTRUCTIONS

#2	x1	#1	x2	①	x2	②	x4	③	x4
									

STEP-4:

1. Mark the position on the wall, that corresponds to the location of bracket ① on the back of top panel A; Drill and insert the expandable screw ② by hammer.

2. Assemble the bracket ① to the wall. Align the hole in the bracket ① with the expandable screw ②, use screw ③ to attach it, tighten screw ③ with screwdriver#2.

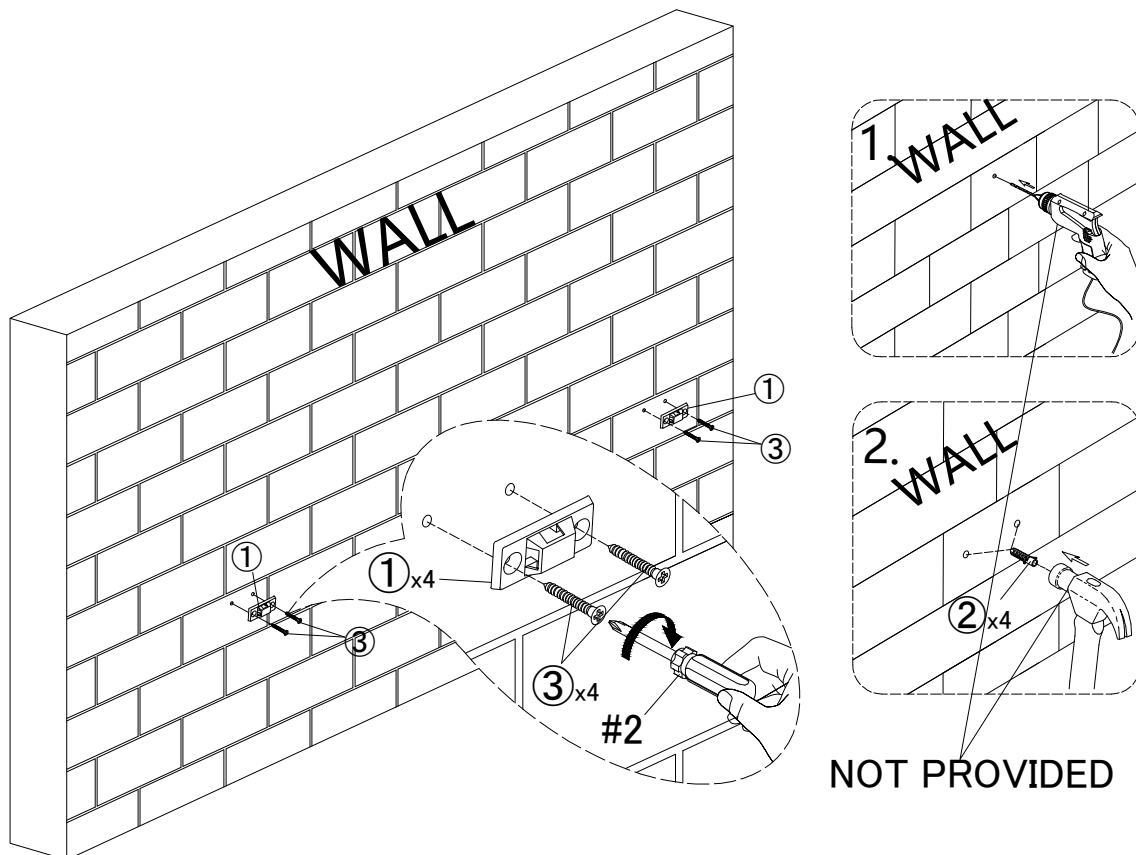

ASSEMBLY INSTRUCTIONS

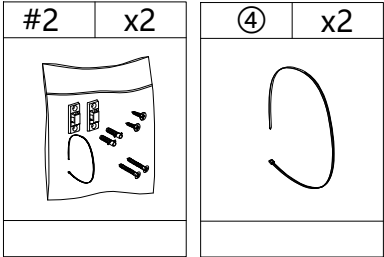

STEP-5

3. Let the plastic belt ③ pass through bracket ① and pull tightly.

If you encounter difficulties during the installation process, please watch the installation video!

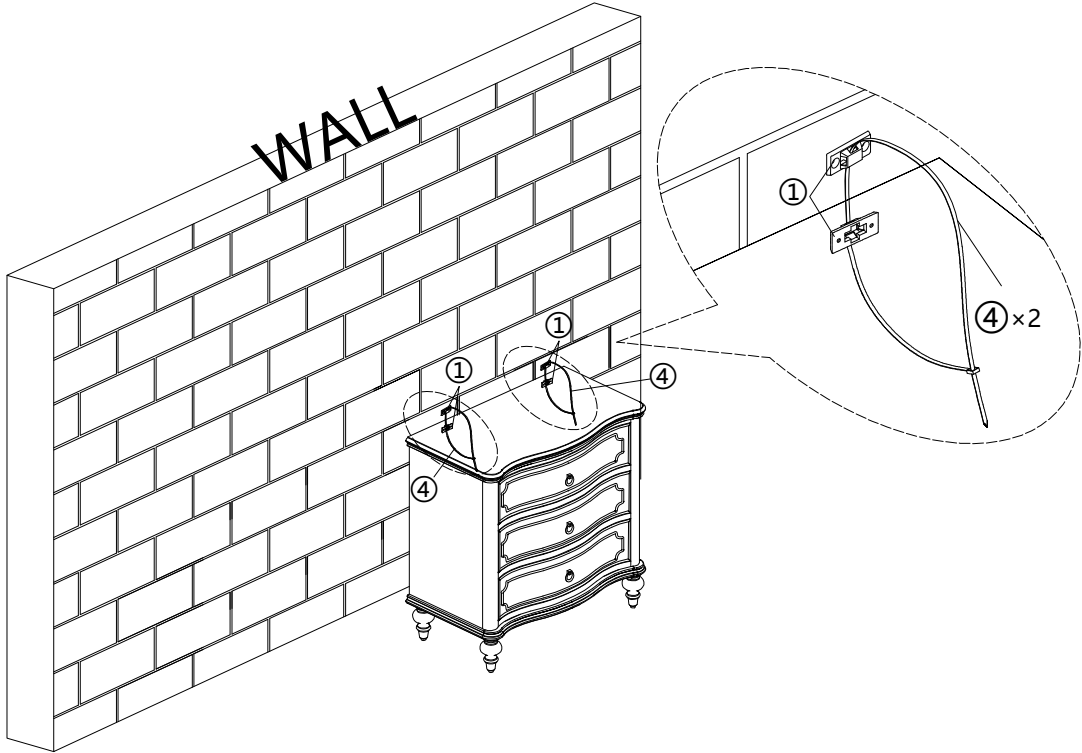

WARRANTY

1. We strive to offer high-quality products, and we also try our best to satisfy each and every customer that orders from us with product or service as needed.
2. We provide 30 days warranty starting from the time you receive the item. Each customer must provide a record of their order such as the order number, or item receipt for any items that are out of the warranty period you may also still receive.
3. Replacement parts by purchasing them with our company if they are available.