

# Installation Diagram

NOTE: (Installed) in the Parts List and Hardware List indicates that it is installed in the finished product, not in the hardware package!!!!

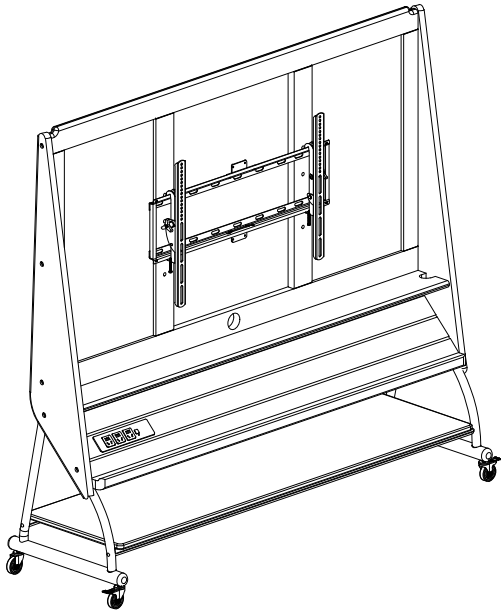

# Parts List

Num.	Name	i con	standard	quantity
1	Left Frame Iron Shelf		470*485*75MM	1
2	left side panel		1116*259*20MM	1
3	Right side frame Iron frame		470*485*75MM	1
4	right side panel		1116*259*20MM	1
5	base plate		1470*400*37MM	1
6	sockets		223*53*29.5mm	1
7	horizontal board		1530*320*50MM	1
8	lami nate		1530*155*20MM	1
9	backpl ane		1530*830*25MM	1
10	TV stand		812*508*65MM	1

# Hardware List

Num.	Name	i con	speci fi cation	quantity
A	Mute casters		∅50*64HMM	2
B	Mute casters with brake		∅50*64HMM	2
C	open-end wrench		12MM	1
D	Countersunk head hexagon socket screws		M6*35MM	10
E	Flat head internal angle screw		M6*30MM	10
F	wood screw		∅3.0*10MM	3
G	Allen key		M4*57MM	1
H	Hexagon socket wire		M7*48MM	4
I	wood tenon		∅10*40MM	4
J	Flat head hexagon socket screws		M6*15MM	8

This product by the wood inspection, paint inspection in full compliance with national quality inspection standards, to confirm that the packaging is intact for sale, in order to ensure our commitment, customers are welcome to our after-sales service to provide valuable advice.

Name	furni ture
Qual i fied	Qual i fied
level	First

standard:

GB/T 3324  
GB/ 18584

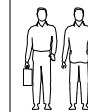

Step 1

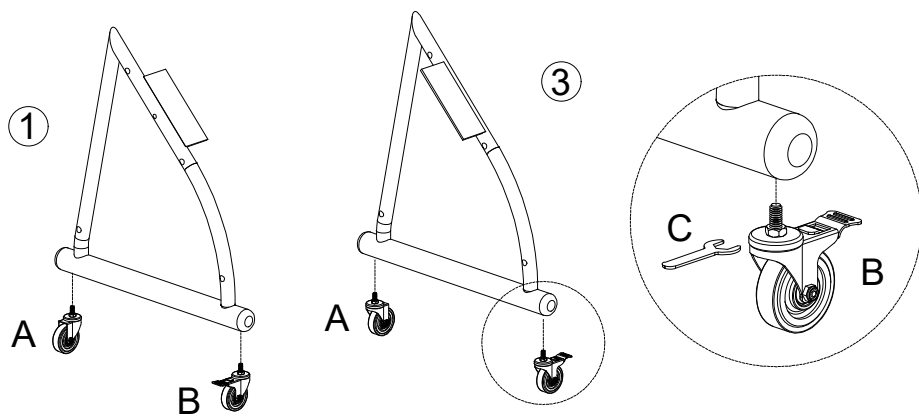

Note: After unpacking, please check the number of assembled parts as shown against the instruction manual to see if they are correct, then assemble as shown. As shown in the picture, fix the hardware A/B with hardware C on the 1/2 parts.

Step 2

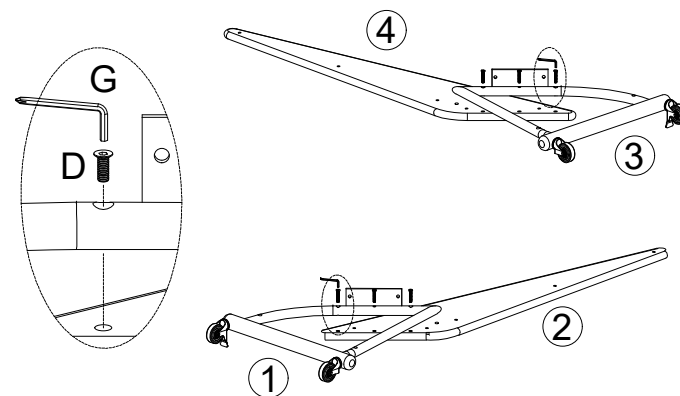

►Connect the parts grouped in step 1 and part 2/4 with hardware D,G as shown.

Step 3

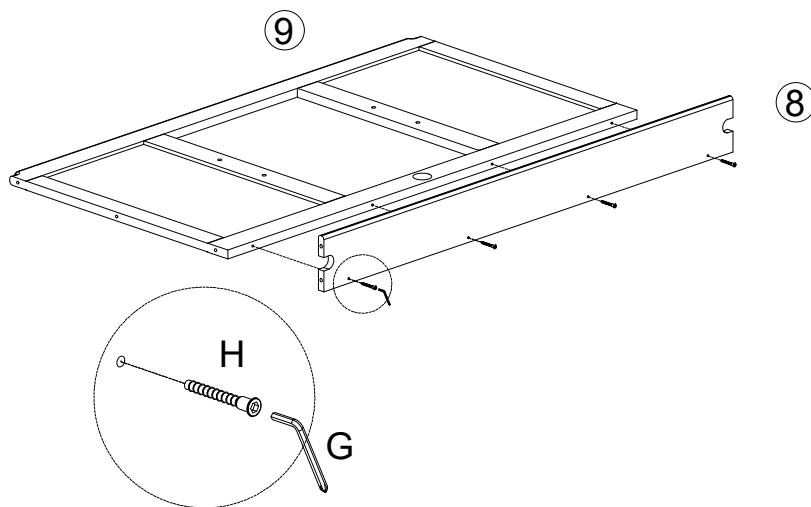

►Connect parts 8/9 with hardware H/G as shown

Step 4

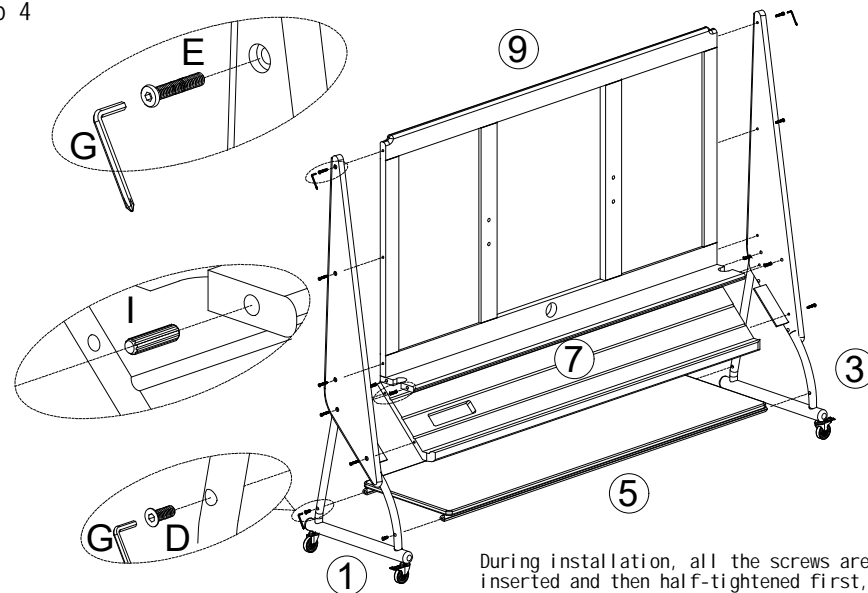

As shown. Connect part 7 and the parts grouped in step 1/2/3 with hardware D/E/I. Tighten again with wrench G.

During installation, all the screws are inserted and then half-tightened first, without tightening them for the time being. After all screws are inserted, tighten them together.

Step 5

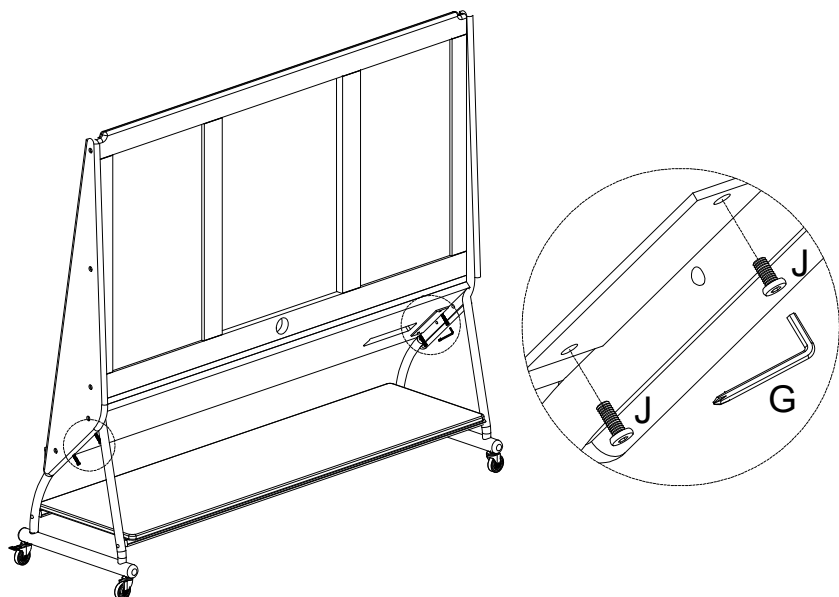

As shown.  
Attach the backs of the parts assembled in step 4 with hardware J ,  
Tighten with wrench G.

Step 6

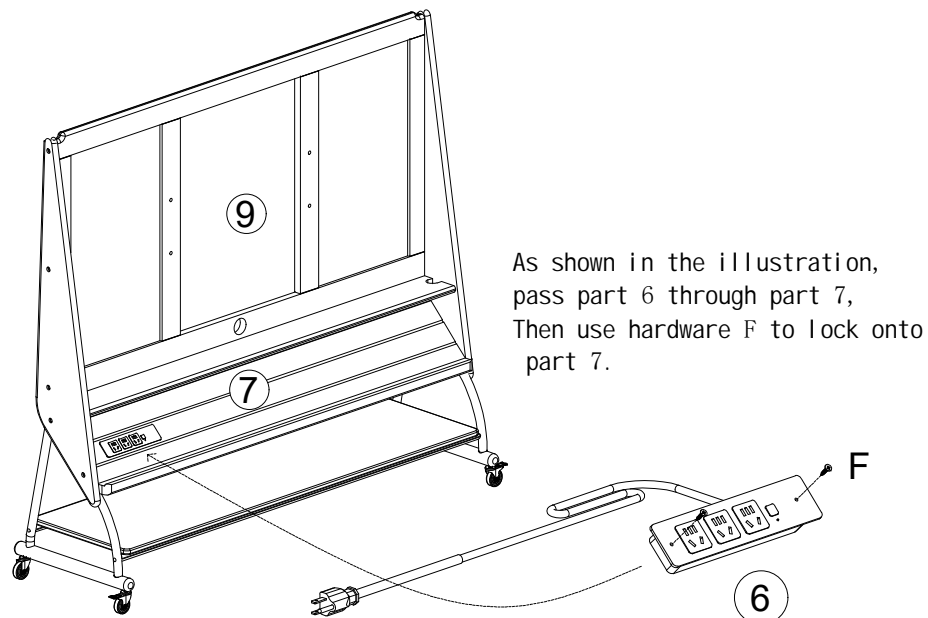

As shown in the illustration,  
pass part 6 through part 7,  
Then use hardware F to lock onto  
part 7.

As shown, the socket 6 is secured with hardware F to the parts grouped in step 5

Step 7

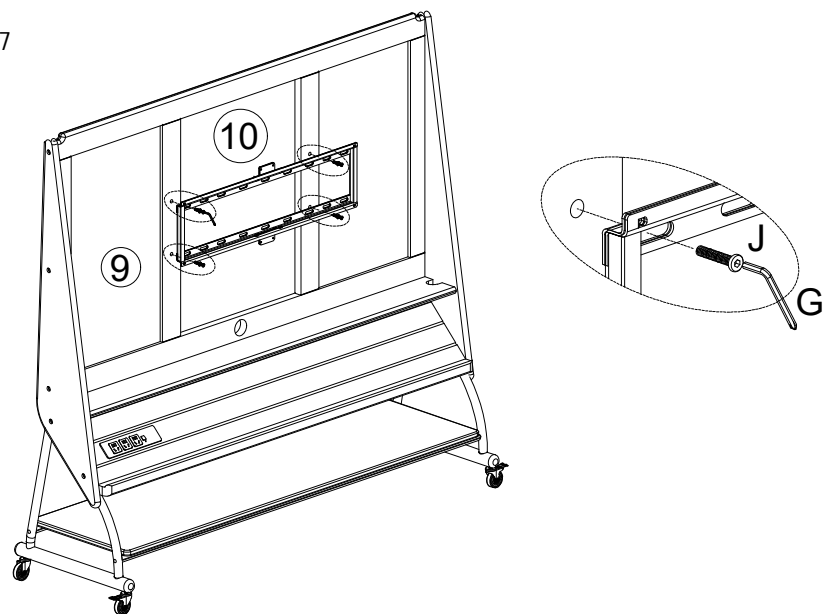

As shown in the figure, use hardware G/J to secure part 10 to  
part 9, and then securely hang the TV set.

Step 8

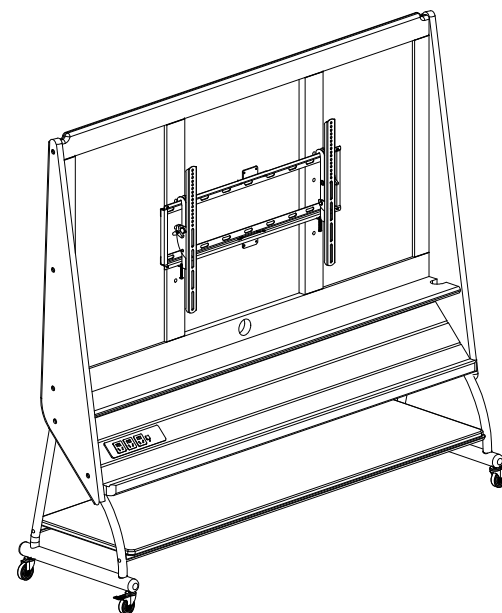

►Assembly is complete.