

CARE AND MAINTENANCE





Wipe clean with a soft, dry cloth. Test the cleaning method on a hidden area before using them over the entire area.

NOTICE

- * Please make sure that you have all parts indicated before you begin assembly of this item.
- * This item should be assembled on a soft surface to prevent scratching the finished product during assembly.
- * This item may require periodic tightening.

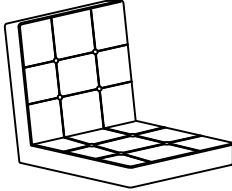
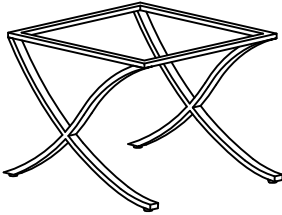
Product Dimensions: 18-1/2"W*23"Dx35"H

Part List and Hardware List

PIECE	DESCRIPTION	PICTURE	QUANTITY
A	Cushion		1x
B	Metal Base		1x
H1	Allen Bolt	 1/4"x1-1/4"	4x
H2	Flat washer	 ϕ 16x1.0	4x
H3	Allen Key	 M4	1x

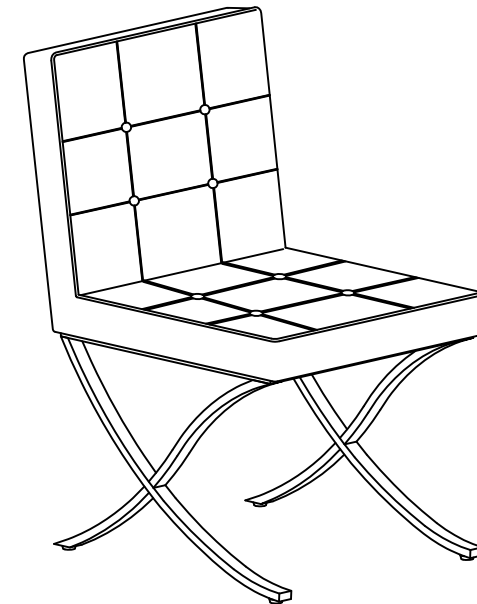

Weight capacity: 275lbs
WARNING: DO NOT STAND ON CHAIR

PREPARATION

Before beginning assembly of product, make sure all parts are present. Compare parts with package contents list and hardware contents list. If any part is missing or damaged, do not attempt to assemble the product.

Estimated Assembly Time: 10 minutes.

Tools Required for Assembly (included): Allen Key

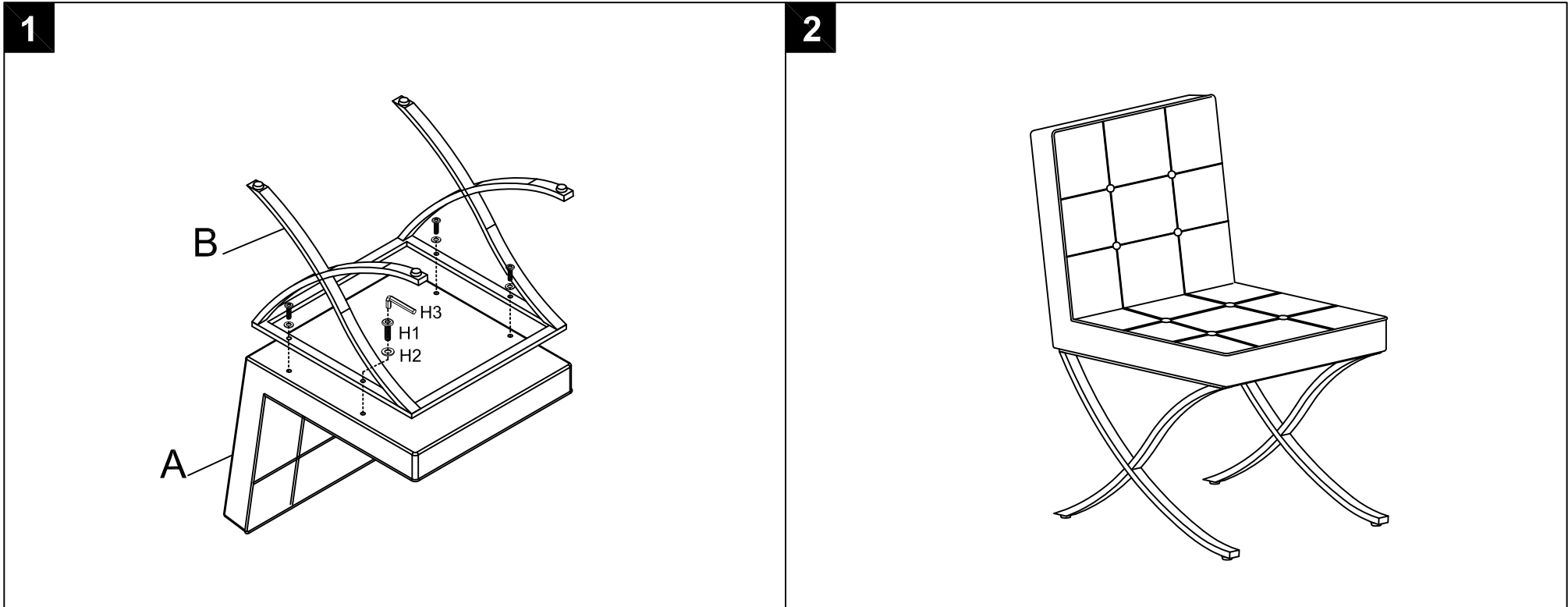

Step 1

Assembly the metal base (B) on the underneath of the cushion (A) by using Allen key (H3) to lock 4*Allen bolts (H1) with 4*flat washers (H2), as picture.

Step 2

Assembly is completed.