

# ASSEMBLY INSTRUCTIONS

MONTAGEANLEITUNG  
INSTRUCTIONS DE MONTAGE  
ISTRUZIONI DI MONTAGGIO  
INSTRUCCIONES DE MONTAJE

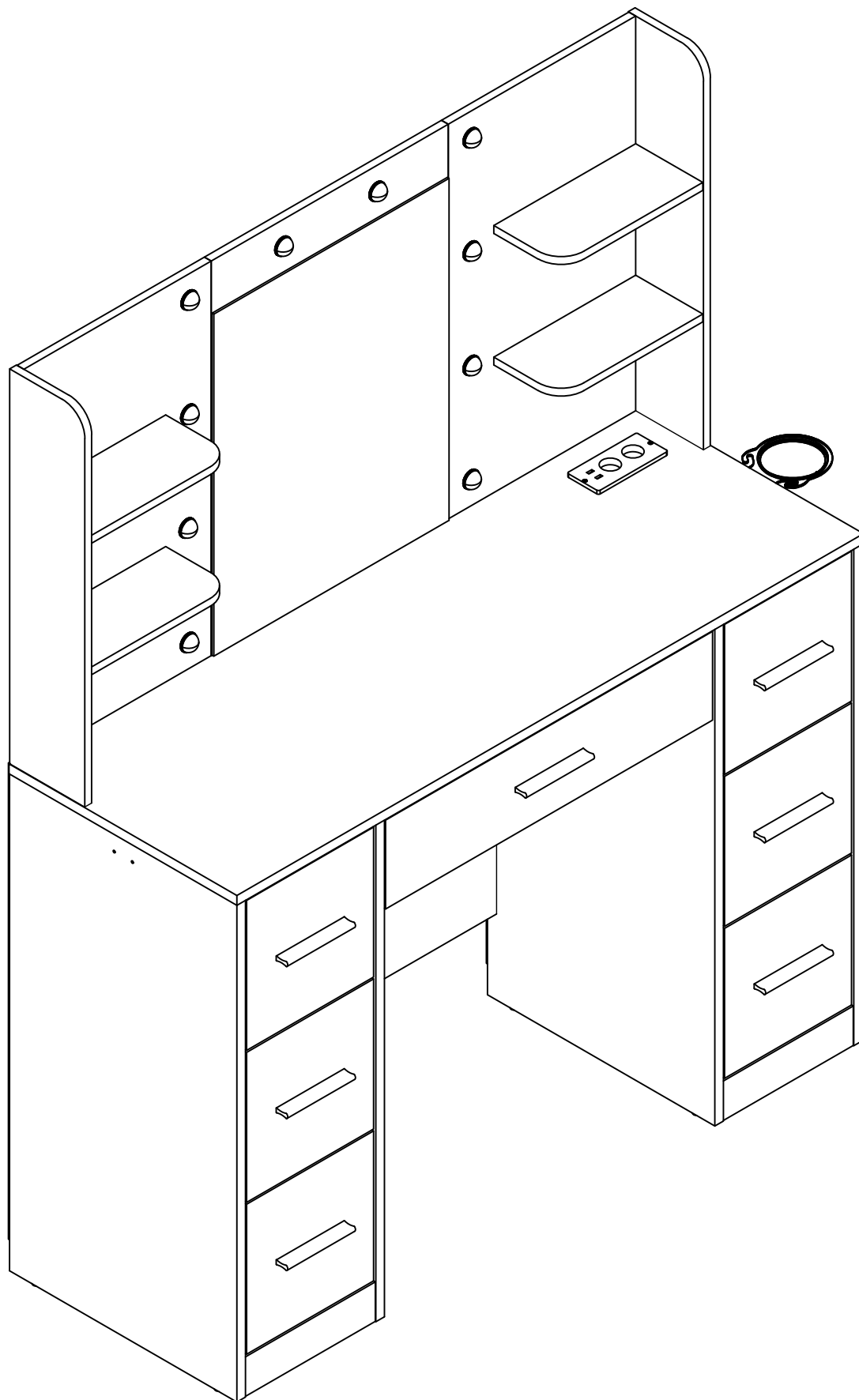

## Warning

This manual is intended to describe the items that you should be aware of when using the product to prevent harm to you and other people and damage to property. For safe use, please be sure to follow the contents of this manual.

Please read this manual carefully before use to ensure the correct and safe use of the product. Also, please read the quality label attached to the product.

The contents of this manual and the precautions for use describe measures to prevent incorrect usage and accidents. Please keep this manual in a safe place and refer to it when necessary. When renting or transferring the product to a third party, be sure to attach this manual and fully explain the handling method.

The precautions written here are intended to prevent harm or damage to you or others. All of these are important guidelines for safe use, so please be sure to observe them.

### 1. **\*\*Prevent Electrical Hazards\*\***

This product contains electrical components (LED lights and light strips). Please ensure that the socket and power cord are intact before use. If the cable is damaged, do not use the product and contact a professional for repair.

Before cleaning or maintenance, be sure to disconnect the power to avoid the risk of electric shock.

Do not allow water or other liquids to come into contact with the lighting components to avoid electrical short circuits or damage.

### 2. **\*\*Prevent Overheating and Fire\*\***

Do not cover the light or LED strip vents to avoid overheating of the equipment.

Do not place the dressing table near high temperatures or heat sources (such as radiators or ovens) to prevent overheating or fire.

### 3. **\*\*Product Assembly and Stability\*\***

When assembling this product, strictly follow the steps in the instruction manual. Ensure that all screws and fasteners are firmly secured to prevent loosening or detachment.

Regularly check the screws and connectors of the product to prevent loosening after long-term use. If loose, tighten them promptly.

When in use, make sure the product is placed on a stable and solid surface to prevent tipping.

### 4. **\*\*Child Safety Protection\*\***

This product is not suitable for children to use alone. During assembly, keep small parts out of the reach of children to prevent choking or suffocation.

Do not allow children to climb on or play around the dressing table to avoid accidental injury or tipping.

### 5. **\*\*Prevent Material Damage\*\***

Avoid exposing this product to direct sunlight or humid environments to prevent material deformation or damage.

Do not use sharp objects on the surface of the dressing table to prevent scratches or damage to the panels.

When tightening screws, avoid over-tightening to prevent the panels from cracking.

### 6. **\*\*Lighting Usage Precautions\*\***

This product is equipped with an LED light strip for indoor use only. When using, avoid looking directly at the light for extended periods to prevent eye discomfort.

Do not disassemble or replace the lighting components yourself. If replacement is necessary, contact a professional technician.

### 7. **\*\*Weight and Load Capacity\*\***

Do not place heavy objects on the dressing table. Exceeding the product's weight limit may cause structural damage or deformation.

---

### **\*\*Important Reminder\*\***

This product is for indoor use only and should not be placed in an outdoor environment. When renting or transferring this product to others, be sure to provide this manual to ensure proper use. Keep this manual for future reference.

## Avvertenza

Questo manuale descrive gli elementi di cui devi essere a conoscenza durante l'uso del prodotto per prevenire danni a te stesso, ad altre persone e alle proprietà. Per un utilizzo sicuro, assicurati di seguire attentamente il contenuto di questo manuale.

Leggi attentamente questo manuale prima dell'uso per garantire un uso corretto e sicuro del prodotto. Leggi anche l'etichetta di qualità allegata al prodotto.

Il contenuto di questo manuale e le precauzioni d'uso descrivono misure per prevenire l'uso scorretto e gli incidenti. Conserva questo manuale in un luogo sicuro e consultalo quando necessario. Quando noleggi o trasferisci il prodotto a una terza parte, assicurati di allegare questo manuale e di spiegare completamente il metodo di utilizzo.

Le precauzioni scritte qui sono intese a prevenire danni o lesioni a te o ad altri. Tutte queste sono linee guida importanti per un uso sicuro, quindi assicurati di rispettarle.

### 1. **\*\*Prevenire i rischi elettrici\*\***

Questo prodotto contiene componenti elettrici (luci LED e strisce luminose). Assicurati che la presa e il cavo di alimentazione siano intatti prima dell'uso. Se il cavo è danneggiato, non utilizzare il prodotto e contatta un professionista per la riparazione.

Prima della pulizia o della manutenzione, scollega l'alimentazione per evitare il rischio di scosse elettriche.

Non consentire che acqua o altri liquidi entrino in contatto con i componenti di illuminazione per evitare cortocircuiti elettrici o danni.

### 2. **\*\*Prevenire il surriscaldamento e gli incendi\*\***

Non coprire le prese d'aria delle luci o delle strisce LED per evitare il surriscaldamento del dispositivo.

Non posizionare il tavolo da toeletta vicino a fonti di calore (come radiatori o forni) per prevenire il surriscaldamento o incendi.

### 3. **\*\*Assemblaggio e stabilità del prodotto\*\***

Durante l'assemblaggio di questo prodotto, segui attentamente i passaggi nel manuale di istruzioni. Assicurati che tutte le viti e i dispositivi di fissaggio siano saldamente serrati per evitare allentamenti o distacchi.

Controlla regolarmente le viti e i connettori del prodotto per prevenire allentamenti dopo un uso prolungato. Se sono allentati, stringili immediatamente.

Durante l'uso, assicurati che il prodotto sia posizionato su una superficie stabile e solida per evitare ribaltamenti.

### 4. **\*\*Protezione dei bambini\*\***

Questo prodotto non è adatto per l'uso da parte di bambini senza supervisione. Durante l'assemblaggio, tieni le piccole parti fuori dalla portata dei bambini per evitare il rischio di soffocamento o ingestione.

Non permettere ai bambini di arrampicarsi o giocare intorno al tavolo da toeletta per evitare lesioni accidentali o ribaltamenti.

### 5. **\*\*Prevenire danni ai materiali\*\***

Evita di esporre questo prodotto alla luce solare diretta o a ambienti umidi per prevenire deformazioni o danni ai materiali.

Non utilizzare oggetti affilati sulla superficie del tavolo da toeletta per evitare graffi o danni ai pannelli.

Quando stringi le viti, evita di stringerle eccessivamente per non danneggiare i pannelli.

### 6. **\*\*Precauzioni sull'uso dell'illuminazione\*\***

Questo prodotto è dotato di una striscia LED, progettata solo per uso interno. Quando lo utilizzi, evita di guardare direttamente la luce per lunghi periodi per prevenire fastidi agli occhi.

Non smontare o sostituire i componenti di illuminazione da solo. Se è necessario sostituirli, contatta un tecnico professionista.

### 7. **\*\*Peso e capacità di carico\*\***

Non posizionare oggetti pesanti sul tavolo da toeletta. Superare il limite di peso del prodotto può causare danni strutturali o deformazioni.

---

### **\*\*Promemoria importante\*\***

Questo prodotto è destinato esclusivamente all'uso interno e non deve essere utilizzato in un ambiente esterno. Quando noleggi o trasferisci questo prodotto ad altre persone, assicurati di fornire questo manuale per garantire un uso corretto. Conserva questo manuale per riferimenti futuri.

---

## Advertencia

Este manual describe los elementos que debe tener en cuenta al utilizar el producto para evitar daños a usted, a otras personas y a la propiedad. Para un uso seguro, asegúrese de seguir el contenido de este manual.

Lea detenidamente este manual antes de usar el producto para garantizar un uso correcto y seguro. Además, lea la etiqueta de calidad adjunta al producto.

El contenido de este manual y las precauciones de uso describen medidas para prevenir el uso incorrecto y los accidentes. Guarde este manual en un lugar seguro y consúltelo cuando sea necesario. Al alquilar o transferir el producto a un tercero, asegúrese de adjuntar este manual y explicar completamente el método de manejo.

Las precauciones escritas aquí están destinadas a prevenir daños o lesiones a usted o a otros. Todas estas son pautas importantes para un uso seguro, por lo que asegúrese de observarlas.

### 1. **\*\*Prevenir peligros eléctricos\*\***

Este producto contiene componentes eléctricos (lucos LED y tiras de luz). Asegúrese de que la toma de corriente y el cable de alimentación estén intactos antes de su uso. Si el cable está dañado, no utilice el producto y póngase en contacto con un profesional para su reparación.

Antes de la limpieza o el mantenimiento, asegúrese de desconectar la alimentación para evitar el riesgo de descarga eléctrica.

No permita que el agua u otros líquidos entren en contacto con los componentes de iluminación para evitar cortocircuitos eléctricos o daños.

### 2. **\*\*Prevenir el sobrecalentamiento y los incendios\*\***

No cubra las rejillas de ventilación de las luces o tiras de LED para evitar el sobrecalentamiento del equipo.

No coloque el tocador cerca de fuentes de calor (como radiadores o hornos) para evitar el sobrecalentamiento o incendios.

### 3. **\*\*Montaje y estabilidad del producto\*\***

Al ensamblar este producto, siga estrictamente los pasos en el manual de instrucciones. Asegúrese de que todos los tornillos y sujetadores estén firmemente asegurados para evitar que se aflojen o se desprendan.

Revise regularmente los tornillos y conectores del producto para evitar el aflojamiento después de un uso prolongado. Si están sueltos, apriételos de inmediato.

Cuando use el producto, asegúrese de que esté colocado sobre una superficie estable y sólida para evitar que se vuelque.

### 4. **\*\*Protección infantil\*\***

Este producto no es adecuado para el uso de niños sin supervisión. Durante el montaje, mantenga las piezas pequeñas fuera del alcance de los niños para evitar el riesgo de asfixia o ingestión.

No permita que los niños trepen o jueguen alrededor del tocador para evitar lesiones accidentales o vuelcos.

### 5. **\*\*Prevenir daños en los materiales\*\***

Evite exponer este producto a la luz solar directa o ambientes húmedos para prevenir deformaciones o daños en los materiales.

No utilice objetos afilados en la superficie del tocador para evitar arañazos o daños en los paneles.

Al apretar los tornillos, evite apretarlos demasiado para no dañar los paneles.

### 6. **\*\*Precauciones en el uso de la iluminación\*\***

Este producto está equipado con una tira de luz LED diseñada solo para uso en interiores. Cuando lo utilice, evite mirar directamente a la luz durante largos períodos para prevenir molestias oculares.

No desmonte ni reemplace los componentes de iluminación usted mismo. Si es necesario reemplazarlos, póngase en contacto con un técnico profesional.

### 7. **\*\*Capacidad de peso y carga\*\***

No coloque objetos pesados en el tocador. Superar el límite de peso del producto puede causar daños estructurales o deformaciones.

---

### **\*\*Recordatorio importante\*\***

Este producto es solo para uso en interiores y no debe colocarse en un entorno exterior. Al alquilar o transferir este producto a otras personas, asegúrese de proporcionar este manual para garantizar un uso correcto. Guarde este manual para futuras consultas.

## Warnung

Dieses Handbuch beschreibt die Punkte, die Sie beim Gebrauch des Produkts beachten sollten, um Schäden für Sie, andere Personen und Eigentum zu vermeiden. Für eine sichere Nutzung befolgen Sie bitte die Anweisungen in diesem Handbuch.

Bitte lesen Sie dieses Handbuch vor der Verwendung sorgfältig durch, um den korrekten und sicheren Gebrauch des Produkts sicherzustellen. Lesen Sie auch das am Produkt angebrachte Qualitätsetikett.

Der Inhalt dieses Handbuchs und die Gebrauchshinweise beschreiben Maßnahmen zur Vermeidung falscher Nutzung und Unfälle. Bewahren Sie dieses Handbuch an einem sicheren Ort auf und lesen Sie es bei Bedarf. Beim Vermieten oder Weitergeben des Produkts an Dritte legen Sie dieses Handbuch bitte bei und erklären Sie die Handhabung vollständig.

Die hier aufgeführten Vorsichtsmaßnahmen dienen dazu, Schäden oder Verletzungen bei Ihnen oder anderen zu vermeiden. Diese Hinweise sind wichtig für die sichere Verwendung, bitte befolgen Sie sie sorgfältig.

### 1. \*\*Vermeidung von Stromschlägen\*\*

Dieses Produkt enthält elektrische Komponenten (LED-Leuchten und Lichtstreifen). Stellen Sie vor der Verwendung sicher, dass die Steckdose und das Netzkabel unbeschädigt sind. Wenn das Kabel beschädigt ist, verwenden Sie das Produkt nicht und wenden Sie sich an einen Fachmann zur Reparatur.

Schalten Sie das Gerät vor der Reinigung oder Wartung aus, um Stromschläge zu vermeiden.

Lassen Sie kein Wasser oder andere Flüssigkeiten mit den Beleuchtungskomponenten in Kontakt kommen, um Kurzschlüsse oder Schäden zu vermeiden.

### 2. \*\*Vermeidung von Überhitzung und Feuer\*\*

Decken Sie die Lüftungsschlitze der Leuchte oder des LED-Streifens nicht ab, um eine Überhitzung des Geräts zu vermeiden.

Stellen Sie den Schminktisch nicht in die Nähe von Wärmequellen (wie Heizkörpern oder Öfen), um Überhitzung oder Feuer zu vermeiden.

### 3. \*\*Produktmontage und Stabilität\*\*

Befolgen Sie beim Zusammenbau dieses Produkts genau die Schritte in der Anleitung. Stellen Sie sicher, dass alle Schrauben und Befestigungselemente festgezogen sind, um ein Lösen oder Ablösen zu verhindern.

Überprüfen Sie regelmäßig die Schrauben und Verbindungen des Produkts, um eine Lockerung nach längerer Nutzung zu vermeiden. Ziehen Sie bei Bedarf lose Schrauben nach.

Stellen Sie sicher, dass das Produkt auf einer stabilen und festen Oberfläche steht, um ein Umkippen zu verhindern.

### 4. \*\*Kindersicherheit\*\*

Dieses Produkt ist nicht für die alleinige Verwendung durch Kinder geeignet. Halten Sie bei der Montage kleine Teile außerhalb der Reichweite von Kindern, um Erstickten oder Verschlucken zu vermeiden.

Lassen Sie Kinder nicht auf den Schminktisch klettern oder in dessen Nähe spielen, um Verletzungen oder ein Umkippen zu vermeiden.

### 5. \*\*Vermeidung von Materialschäden\*\*

Vermeiden Sie es, dieses Produkt direktem Sonnenlicht oder feuchten Umgebungen auszusetzen, um Materialverformungen oder -schäden zu verhindern.

Verwenden Sie keine scharfen Gegenstände auf der Oberfläche des Schminktisches, um Kratzer oder Beschädigungen der Platten zu vermeiden.

Vermeiden Sie ein Überdrehen der Schrauben, um ein Brechen der Platten zu verhindern.

### 6. \*\*Beleuchtungshinweise\*\*

Dieses Produkt ist mit einem LED-Lichtstreifen ausgestattet und nur für den Innenbereich vorgesehen. Vermeiden Sie es, längere Zeit direkt in das Licht zu schauen, um Augenbeschwerden zu vermeiden.

Zerlegen oder ersetzen Sie die Beleuchtungskomponenten nicht selbst. Bei Bedarf wenden Sie sich an einen Fachmann.

### 7. \*\*Gewicht und Belastungskapazität\*\*

Stellen Sie keine schweren Gegenstände auf den Schminktisch. Überschreiten Sie nicht die Belastungsgrenze des Produkts, da dies zu strukturellen Schäden oder Verformungen führen kann.

---

### \*\*Wichtiger Hinweis\*\*

Dieses Produkt ist nur für den Innenbereich vorgesehen und darf nicht in einer Außenumgebung verwendet werden. Beim Vermieten oder Weitergeben dieses Produkts an andere Personen stellen Sie sicher, dass dieses Handbuch beigelegt wird, um eine ordnungsgemäße Nutzung zu gewährleisten. Bewahren Sie dieses Handbuch für zukünftige Referenz auf.

## Avertissement

Ce manuel décrit les éléments dont vous devez être conscient lors de l'utilisation du produit afin de prévenir tout danger pour vous-même, d'autres personnes et des dommages matériels. Pour une utilisation en toute sécurité, veuillez suivre attentivement les consignes de ce manuel.

Veuillez lire attentivement ce manuel avant utilisation pour assurer une utilisation correcte et sécurisée du produit. Lisez également l'étiquette de qualité attachée au produit.

Le contenu de ce manuel et les précautions d'utilisation décrivent les mesures pour éviter une mauvaise utilisation et les accidents. Conservez ce manuel dans un endroit sûr et consultez-le en cas de besoin. Lorsque vous louez ou transférez le produit à un tiers, assurez-vous de joindre ce manuel et d'expliquer complètement les instructions d'utilisation.

Les précautions énoncées ici visent à prévenir les dommages ou les blessures à vous ou à autrui. Toutes ces consignes sont importantes pour une utilisation en toute sécurité, veuillez donc les respecter.

### 1. \*\*Prévenir les risques électriques\*\*

Ce produit contient des composants électriques (lampes LED et bandes lumineuses). Veuillez vous assurer que la prise et le câble d'alimentation sont intacts avant utilisation. Si le câble est endommagé, n'utilisez pas le produit et contactez un professionnel pour une réparation.

Avant de procéder au nettoyage ou à la maintenance, assurez-vous de débrancher l'alimentation électrique afin d'éviter tout risque d'électrocution.

Ne laissez pas l'eau ou d'autres liquides entrer en contact avec les composants d'éclairage pour éviter les courts-circuits ou les dommages.

### 2. \*\*Prévenir la surchauffe et les incendies\*\*

Ne couvrez pas les aérations des lampes ou des bandes lumineuses LED afin d'éviter toute surchauffe de l'équipement.

Ne placez pas la coiffeuse à proximité de sources de chaleur (comme des radiateurs ou des fours) afin de prévenir les risques de surchauffe ou d'incendie.

### 3. \*\*Assemblage et stabilité du produit\*\*

Lors de l'assemblage de ce produit, suivez scrupuleusement les étapes décrites dans le manuel. Assurez-vous que toutes les vis et les attaches sont fermement fixées pour éviter tout desserrage ou détachement.

Vérifiez régulièrement les vis et les connecteurs du produit afin de prévenir tout desserrage dû à une utilisation prolongée. Si elles sont desserrées, resserrez-les rapidement.

Lors de l'utilisation, assurez-vous que le produit est placé sur une surface stable et solide afin d'éviter tout basculement.

### 4. \*\*Protection des enfants\*\*

Ce produit n'est pas adapté à une utilisation par des enfants sans surveillance. Lors de l'assemblage, gardez les petites pièces hors de la portée des enfants afin de prévenir tout risque d'étouffement ou d'ingestion.

Ne laissez pas les enfants grimper ou jouer autour de la coiffeuse pour éviter les blessures accidentelles ou le basculement.

### 5. \*\*Prévenir les dommages matériels\*\*

Évitez d'exposer ce produit à la lumière directe du soleil ou à des environnements humides pour prévenir toute déformation ou détérioration des matériaux.

N'utilisez pas d'objets tranchants sur la surface de la coiffeuse afin d'éviter les rayures ou les dommages aux panneaux.

Lors du serrage des vis, évitez de trop serrer pour ne pas endommager les panneaux.

### 6. \*\*Précautions concernant l'utilisation de l'éclairage\*\*

Ce produit est équipé d'une bande lumineuse LED, conçue uniquement pour une utilisation en intérieur. Lors de l'utilisation, évitez de regarder directement la lumière pendant de longues périodes afin de prévenir la fatigue oculaire.

Ne démontez pas et ne remplacez pas vous-même les composants d'éclairage. Si un remplacement est nécessaire, contactez un technicien professionnel.

### 7. \*\*Poids et capacité de charge\*\*

Ne placez pas d'objets lourds sur la coiffeuse. Dépassez la limite de poids du produit peut causer des dommages structurels ou des déformations.

---

### \*\*Rappel important\*\*

Ce produit est destiné à une utilisation en intérieur uniquement et ne doit pas être utilisé en extérieur. Lors de la location ou du transfert de ce produit à une autre personne, assurez-vous de fournir ce manuel pour garantir une utilisation correcte. Conservez ce manuel pour une consultation ultérieure.

# WARNING!

WARNHINWEIS!  
AVERTISSEMENT!  
AVVERTIMENTO!  
ADVERTENCIA!

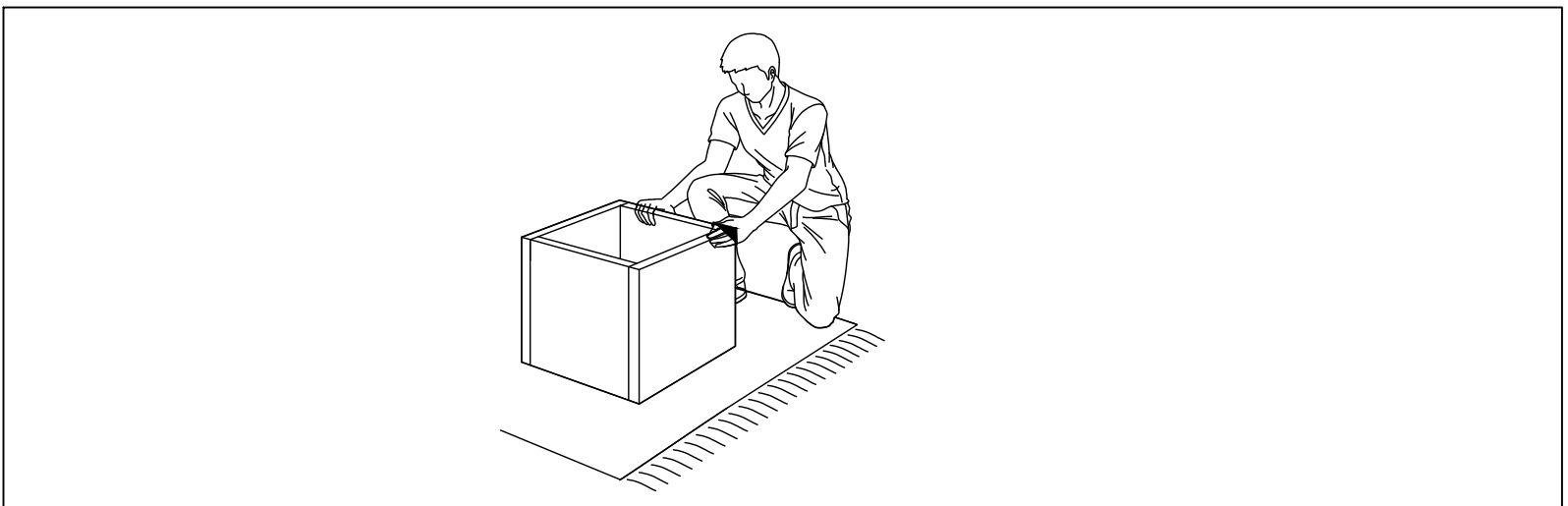
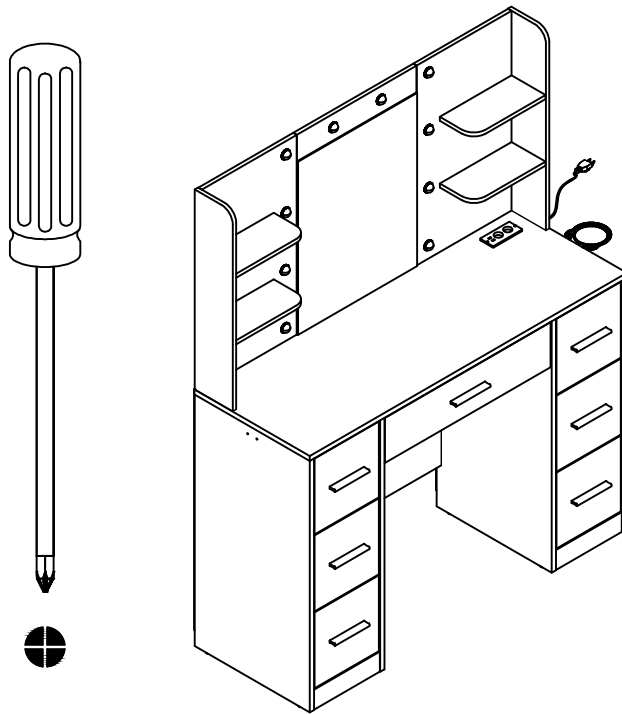

Assemble the furniture on an empty carton, carpet or rug to prevent scratches or damage.

Verwenden Sie bei der Montage einen Karton, Teppich oder eine andere weiche Unterlage um Kratzer und Beschädigungen zu vermeiden.

Lors de l'assemblage, utilisez une boîte en carton, un tapis ou toute autre surface douce pour éviter les rayures et les dommages.

Durante il montaggio, utilizzare una scatola di cartone, un tappeto o un'altra superficie morbida per evitare graffi e danni.

Al realizar el montaje, utilice una caja de cartón, alfombra u otra superficie suave para evitar rayones y daños.

# WARNING!

WARNHINWEIS!  
AVERTISSEMENT!  
AVVERTIMENTO!  
¡ADVERTENCIA!

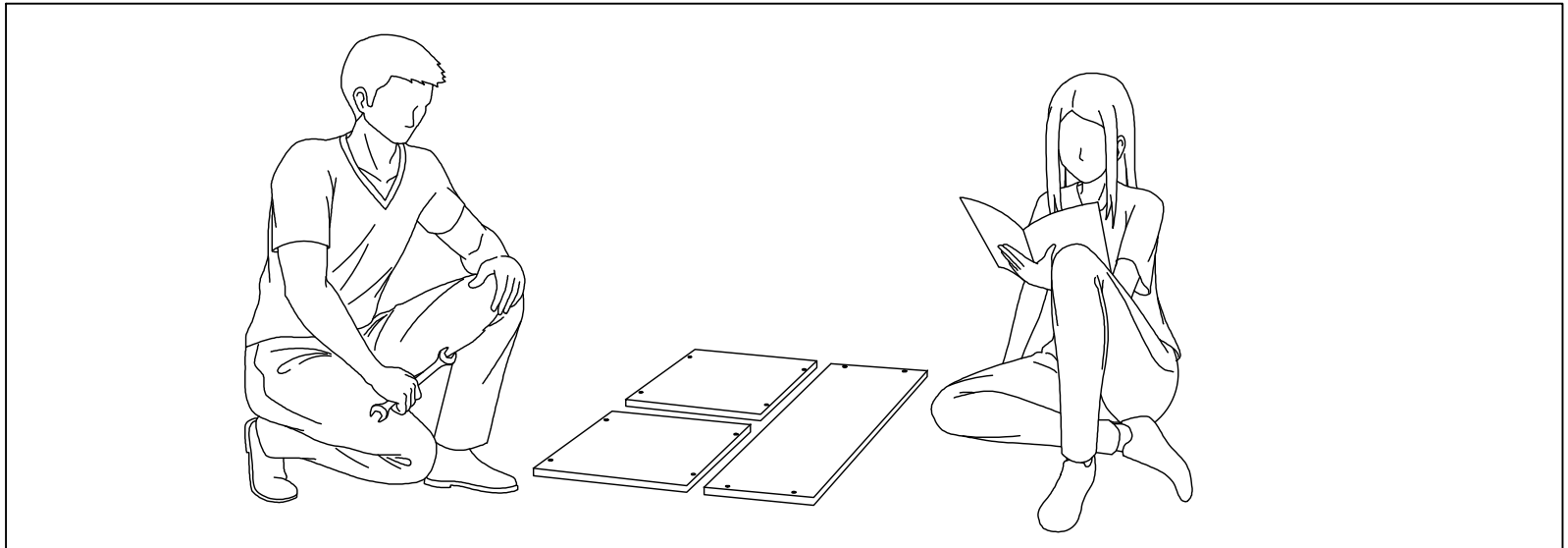

This furniture requires two people for assembly. Make sure no parts are missing or damaged prior to assembly.

Fuer den Zusammenbau dieses Moebelstuecks werden zwei Personen benoetigt. Versichern Sie sich, dass alle Teile vorhanden und unbeschaedigt sind bevor Sie mit dem Zusammenbau beginnen.

Deux personnes sont nécessaires pour assembler ce meuble. Assurez-vous que toutes les pièces sont présentes et en bon état avant de commencer l'assemblage.

Sono necessarie due persone per montare questo mobile. Assicurarsi che tutte le parti siano presenti e non danneggiate prima di iniziare il montaggio.

Se necesitan dos personas para montar este mueble. Asegúrese de que todas las piezas estén presentes y sin daños antes de comenzar el montaje.

Not actual size

Keine Originalgroesse/Pas de taille originale  
/Dimensioni non originali/Tamaño no original

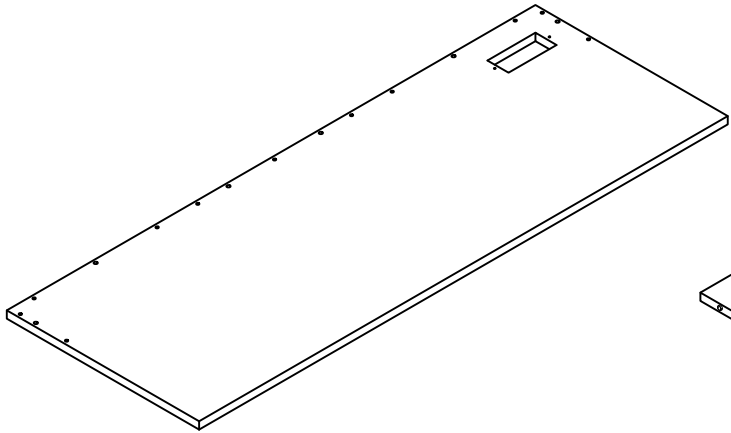

① X1

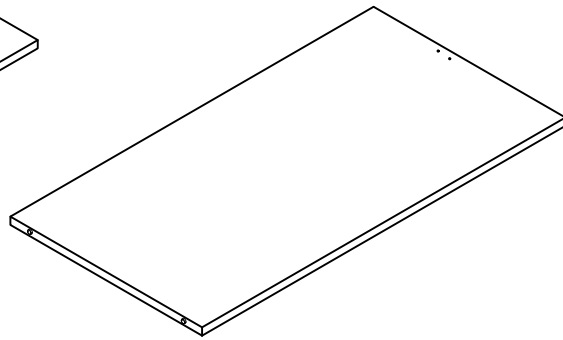

② X1

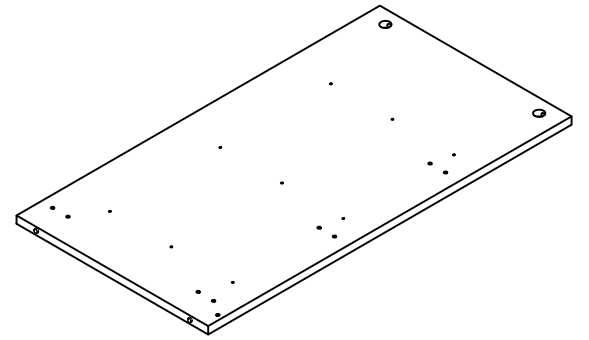

③ X1

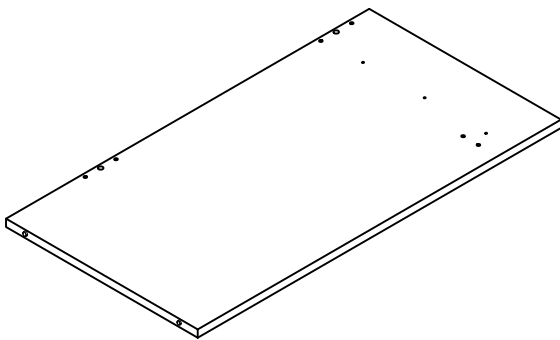

④ X1

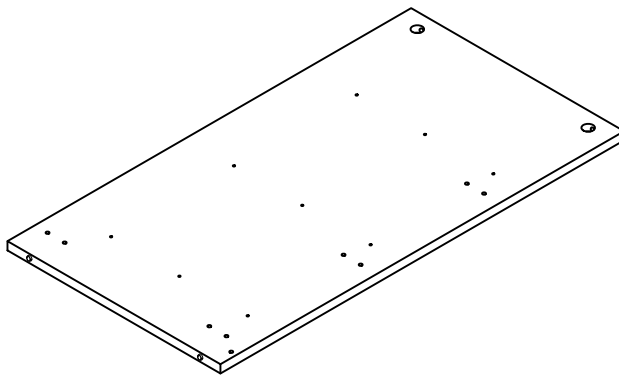

⑤ X1

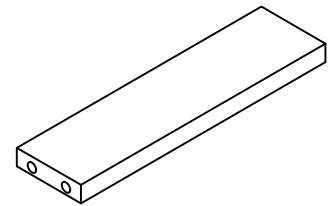

⑥ X4

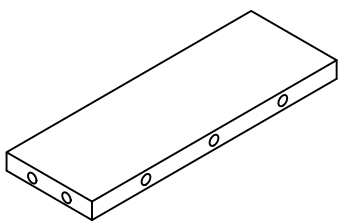

⑦ X2

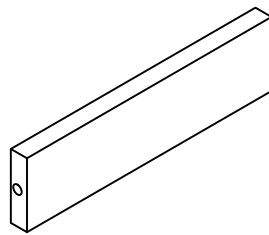

⑧ X2

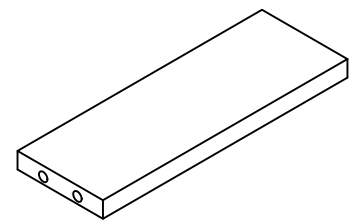

⑨ X2

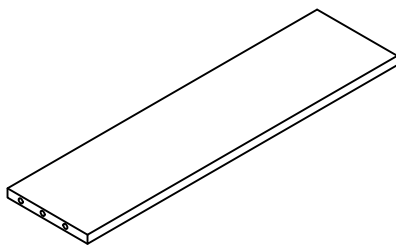

⑩ X1

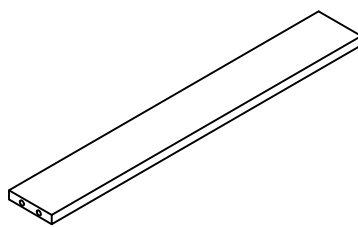

⑪ X1

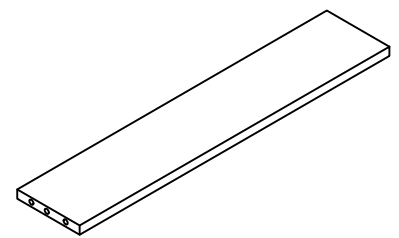

⑫ X1

# BOARD IDENTIFICATION

## IDENTIFICATION DU CIRCUIT IMPRIME

Not actual size

Keine Originalgroesse/Pas de taille originale  
/Dimensioni non originali/Tamaño no original

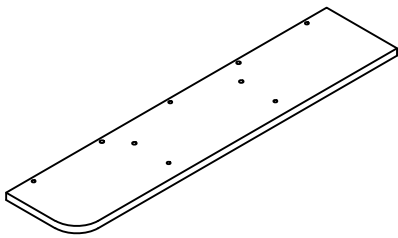

⑬ X1

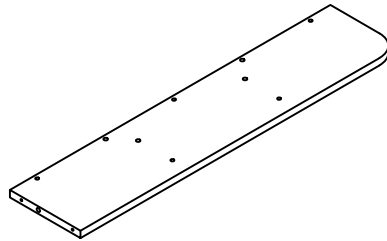

⑭ X1

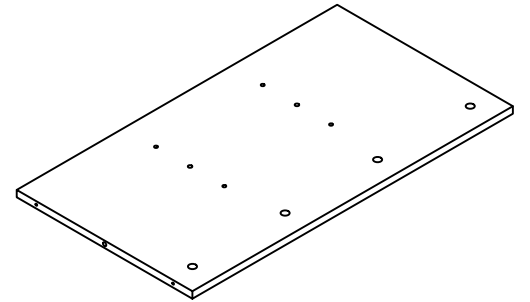

⑮ X1

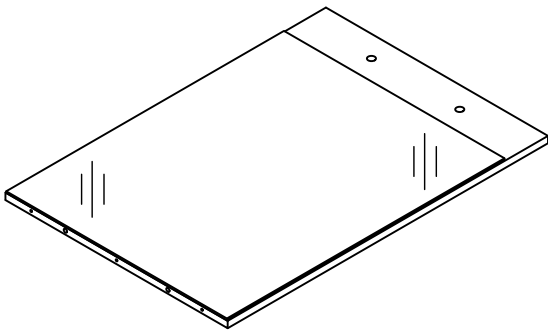

⑯ X1

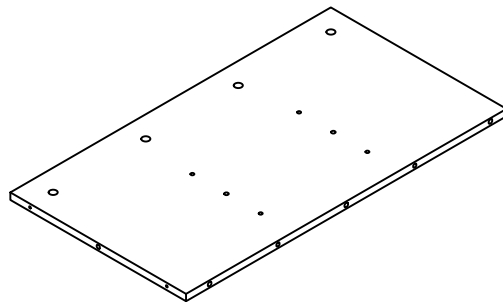

⑰ X1

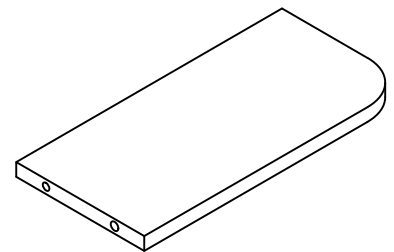

⑱ X2

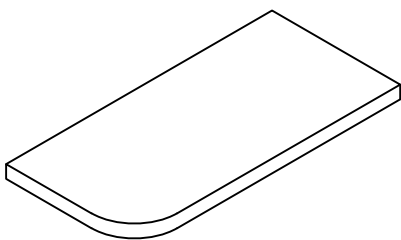

⑲ X2

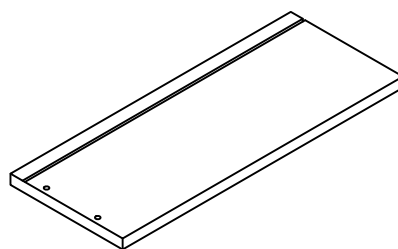

⑳ X5

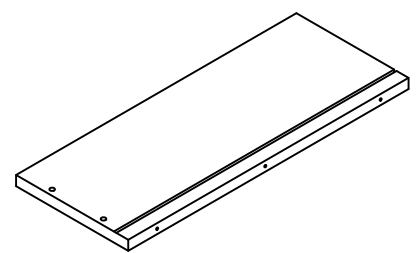

㉑ X5

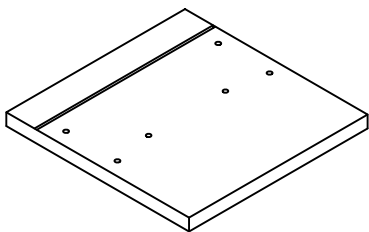

㉒ X6

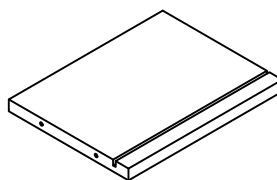

㉓ X6

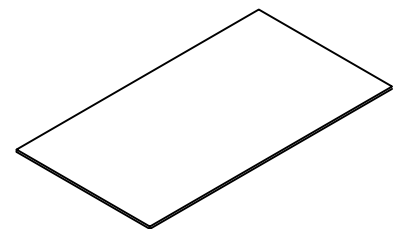

㉔ X5

# BOARD IDENTIFICATION

## IDENTIFICATION DU CIRCUIT IMPRIME

Not actual size

Keine Originalgroesse/Pas de taille originale  
/Dimensioni non originali/Tamaño no original

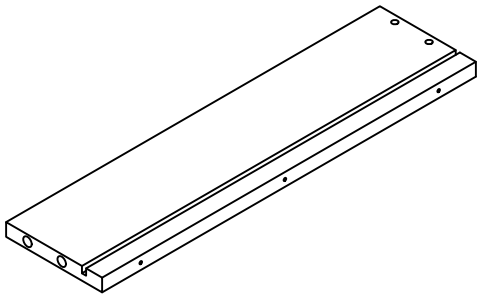

②⑤ X1

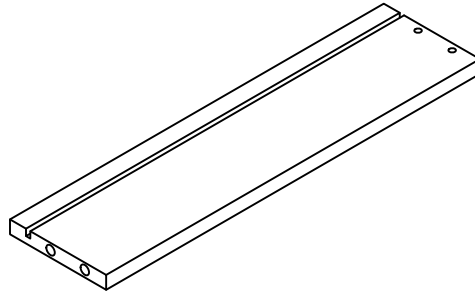

②⑥ X1

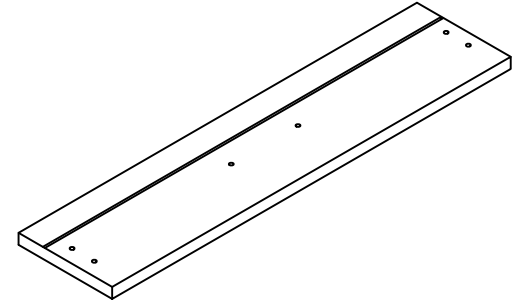

②⑦ X1

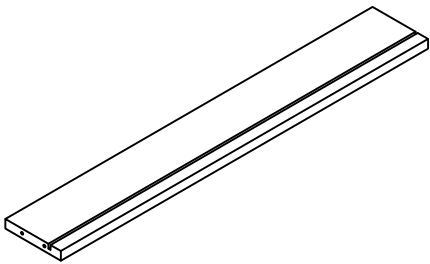

②⑧ X1

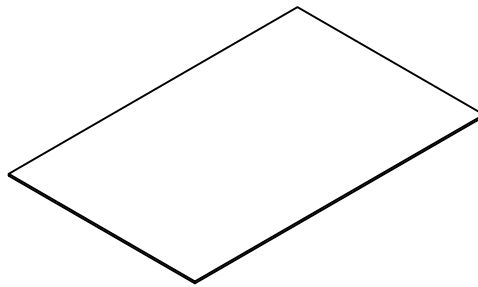

②⑨ X1

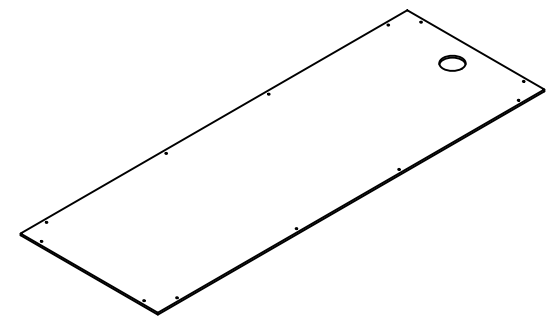

③⑦ X2

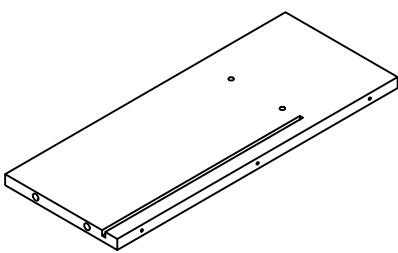

③① X1

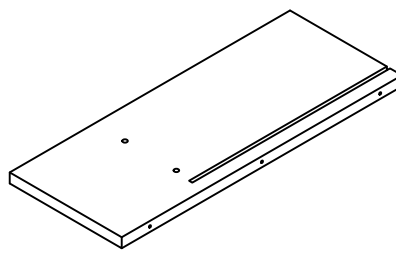

③② X1

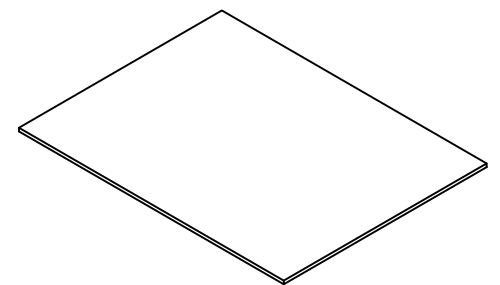

③③ X1







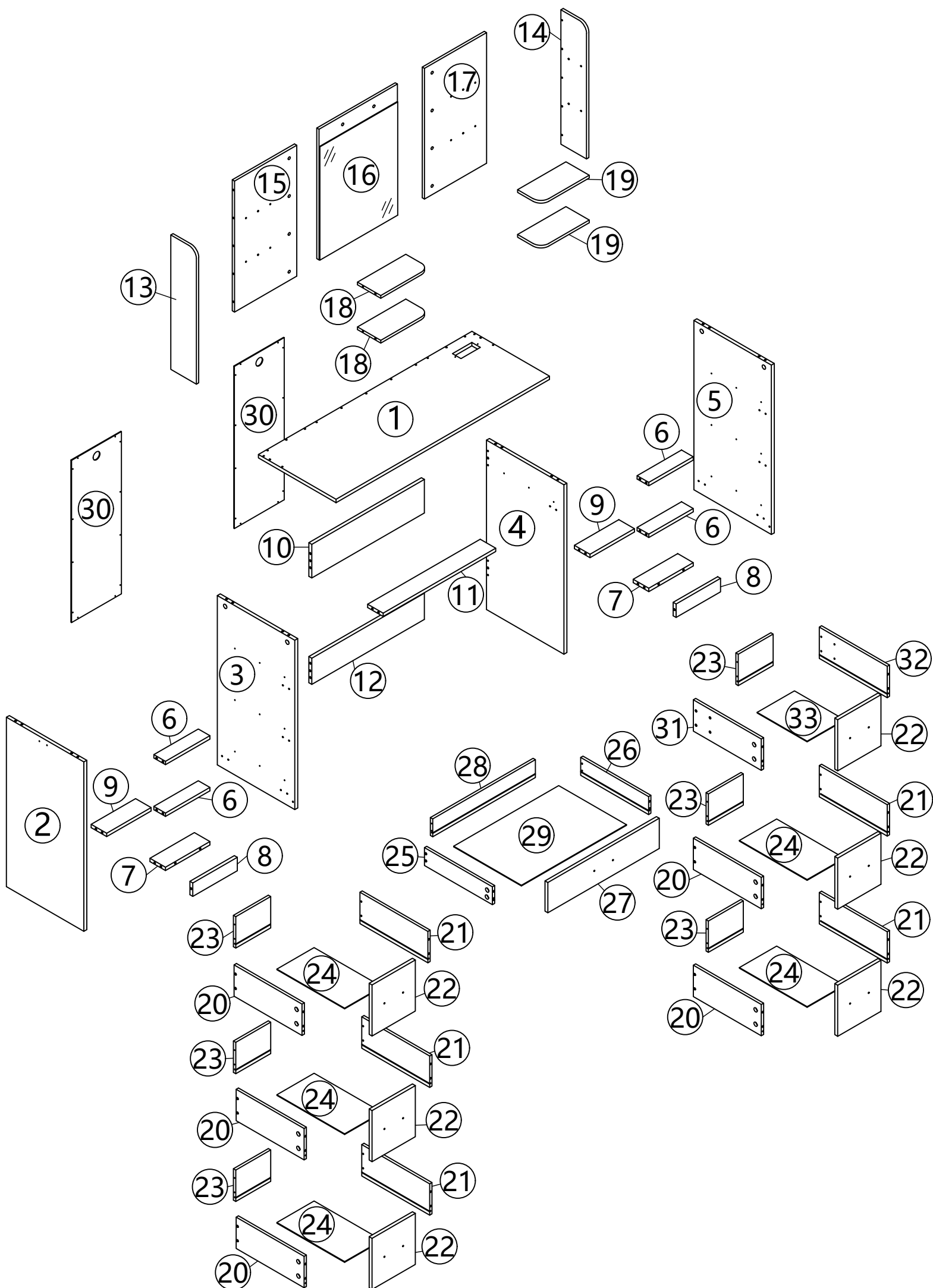

# PACKAGE CONTENT

# CONTENU DE L'EMBALLAGE

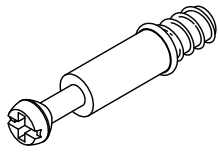
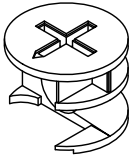
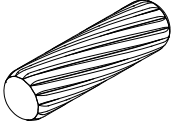
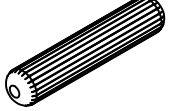

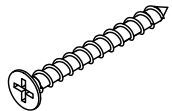
# HARDWARE PART LIST

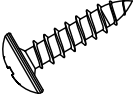
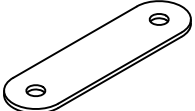
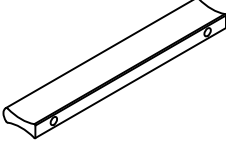
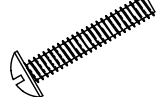
## LISTE DES PIÈCES DE MATÉRIEL

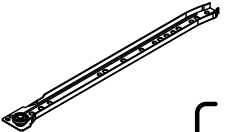
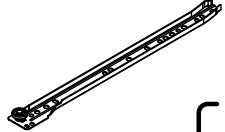
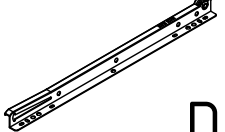
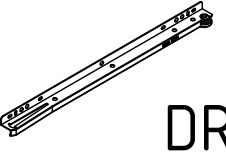
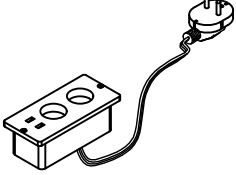
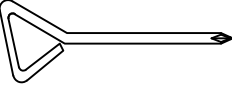
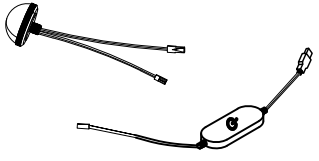
<p>(A) X104+3</p>  <p>∅6.5*35</p>	<p>(B) X104+3</p>  <p>∅15*9.5</p>	<p>(C) X16+1</p>  <p>∅8*30</p>	<p>(D) X18+1</p>  <p>∅6*30</p>
<p>(E) X84+3</p>  <p>∅3.5*14</p>	<p>(F) X14+1</p>  <p>∅3*12</p>	<p>(G) X39+2</p>  <p>∅4*35</p>	<p>(H) X24+2</p>  <p>∅3*14</p>
<p>(I) X2</p>  <p>∅4*14</p>	<p>(J) X6</p>  <p>12*45</p>	<p>(K) X7</p>  <p>106*16*8</p>	<p>(L) X14</p>  <p>∅4*18</p>
<p>(M) X1</p>  <p>109*99*38.5</p>	<p>(N) X7</p>  <p>CL L=350</p>	<p>(N) X7</p>  <p>CR L=350</p>	<p>(N) X7</p>  <p>DL L=350</p>
<p>(N) X7</p>  <p>DR L=350</p>	<p>(O) X1</p> 	<p>(P) X1</p>  <p>70*30*5</p>	<p>(Q) X10+2</p> 

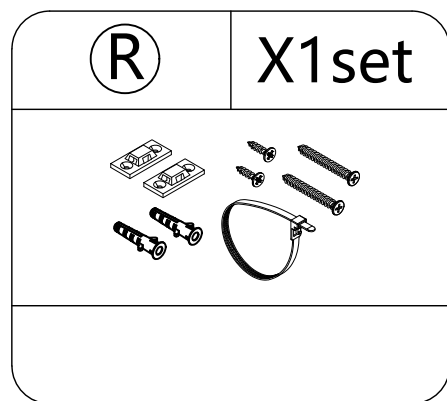

### Cam Lock Fastening System

/Nockenbolzen Verankerungssystem

/Système d'ancrage par boulon à came

/Sistema di ancoraggio con bullone a camma

/Sistema de anclaje con pernos de leva

Insert the cam bolt into the hole first, then insert the cam lock and fasten it.

/Führen Sie zuerst den Nockenbolzen in das Bohrloch ein, anschliessend stecken Sie die den Haltenocken in die dafür vorgesehene Öffnung und ziehen ihn an.

/Insérez d'abord le boulon à came dans le trou percé, puis insérez la came de retenue dans l'ouverture prévue et serrez-la.

/Inserire prima il bullone della camma nel foro, quindi inserire la camma di fissaggio nell'apposita apertura e serrarla.

/Primero inserte el perno de leva en el orificio perforado, luego inserte la leva de retención en la abertura prevista y apriétela.

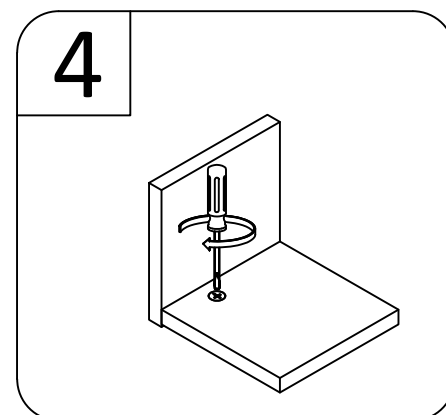
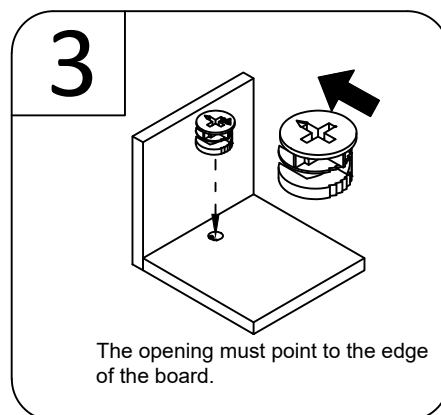
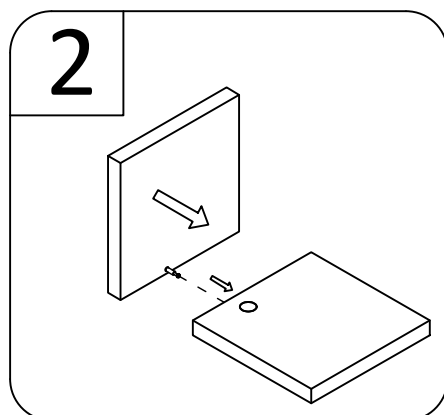
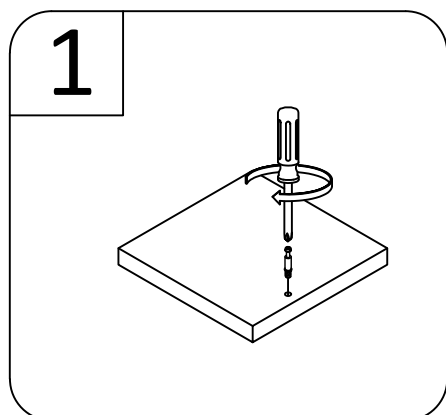

/Das offene Ende des Haltenockens muss in Richtung der Kante des Bauteils zeigen.

/L'extrémité ouverte de la came de retenue doit pointer vers le bord du composant.

/L'estremità aperta della camma di fissaggio deve essere rivolta verso il bordo del componente.

/El extremo abierto de la leva de retención debe apuntar hacia el borde del componente.

STEP 1  
 SCHRITT 1  
 ÉTAPE 1  
 PASSO 1  
 PASO 1

(E)	X18
	
Ø3.5*14	

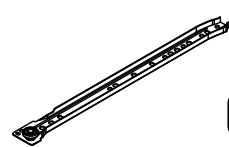
(N)	X3
	
CL	
L=350	

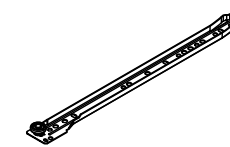
(N)	X3
	
CR	
L=350	

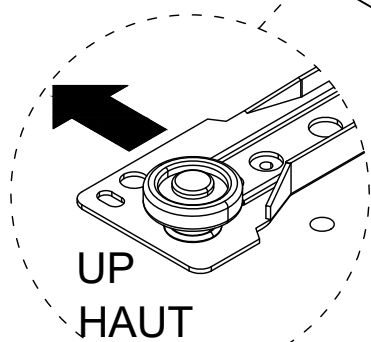
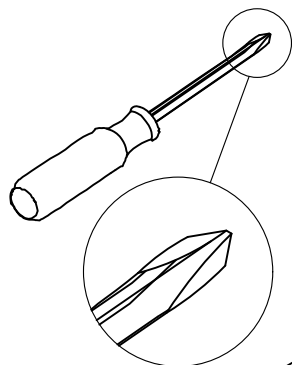

UP  
 HAUT  
 ARRIBA  
 SUPERIORE  
 OBERSEITE

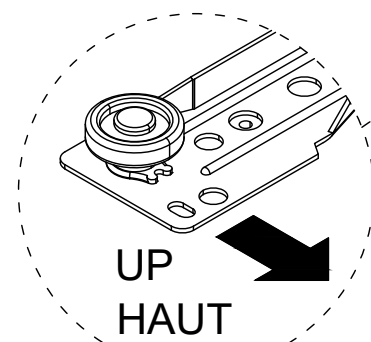

UP  
 HAUT  
 ARRIBA  
 SUPERIORE  
 OBERSEITE

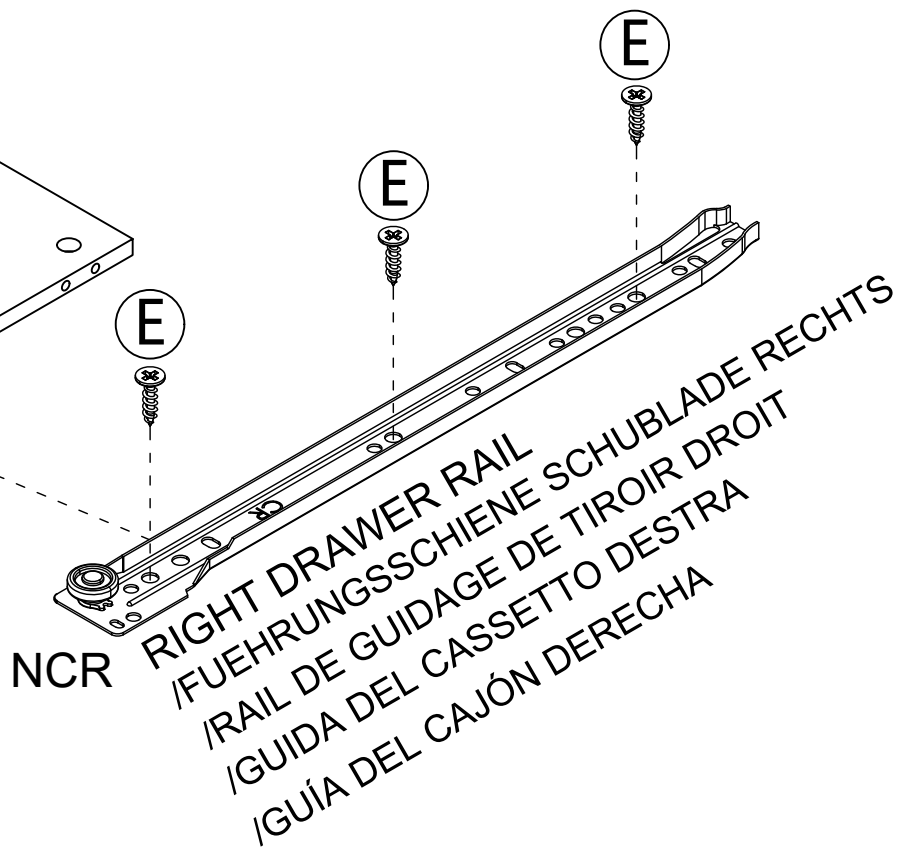
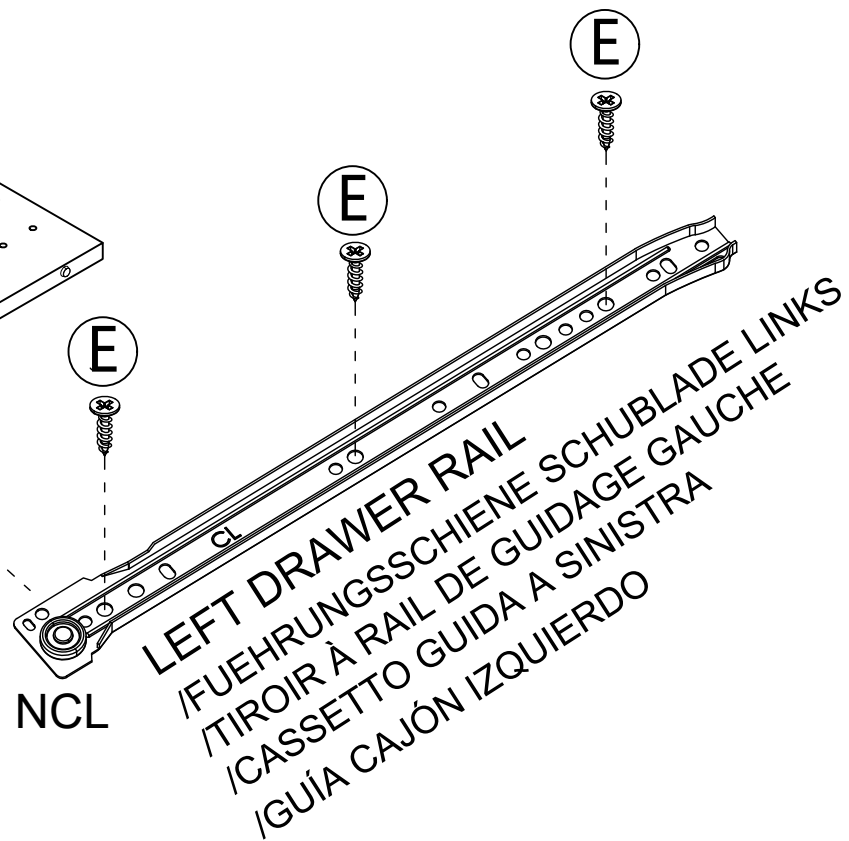
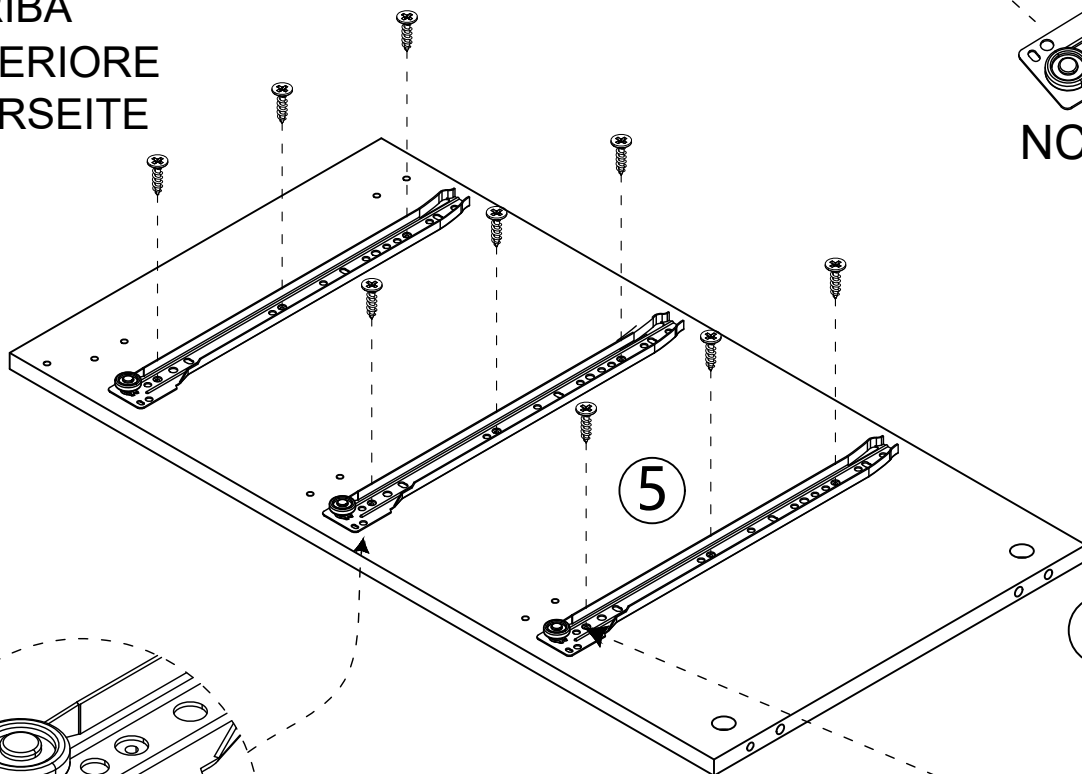
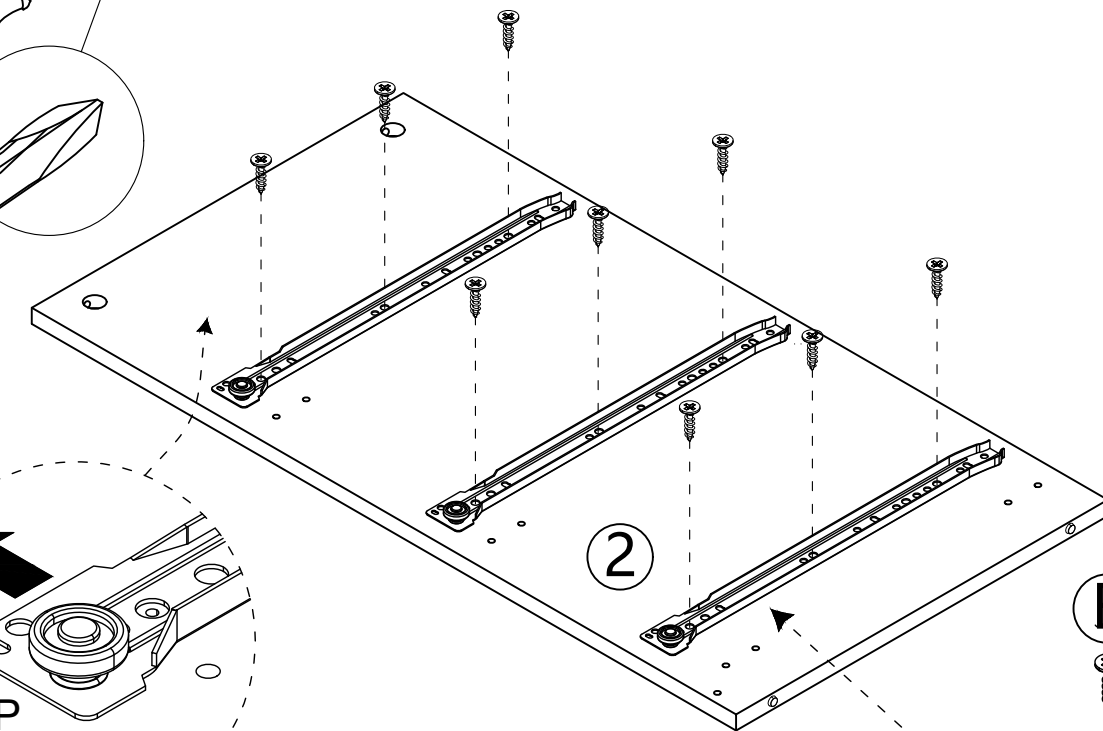

STEP 2  
SCHRITT 2  
ÉTAPE 2  
PASSO 2  
PASO 2

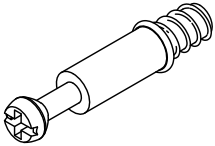
(A)	X18
	
ø6.5*35	

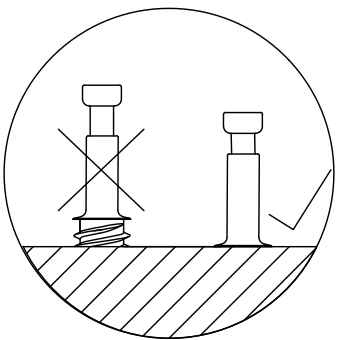
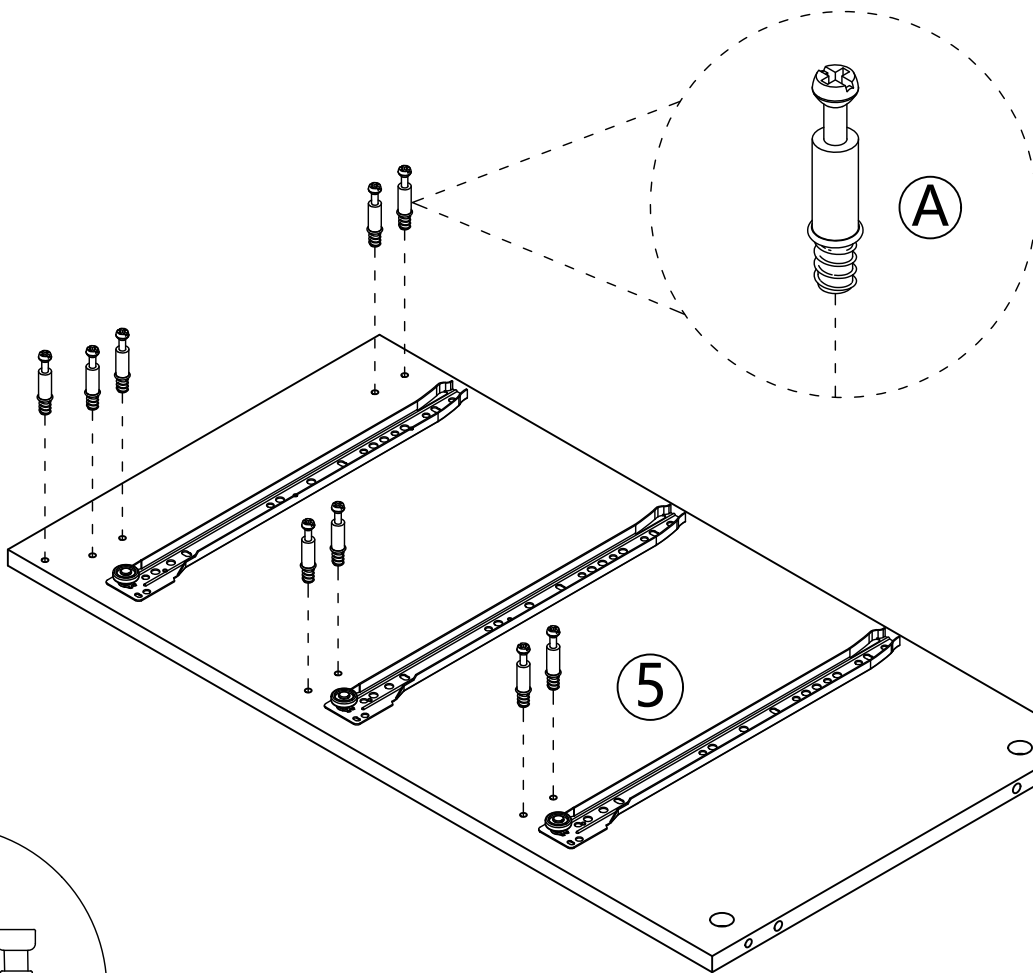
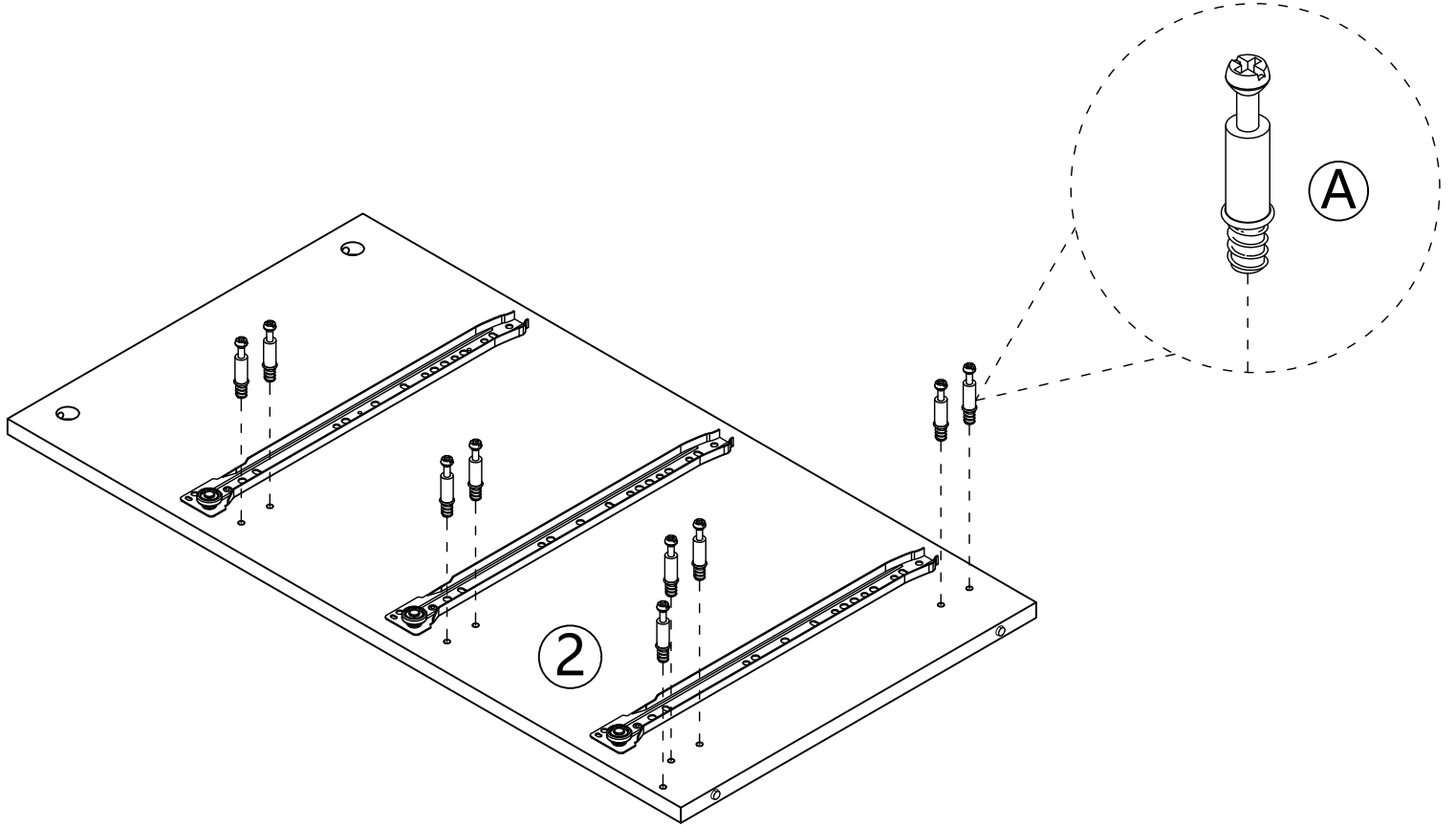
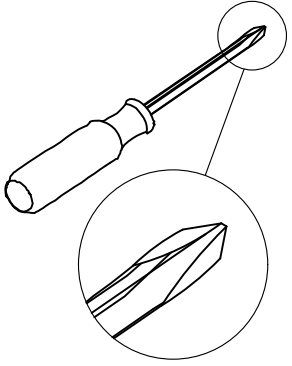

**STEP 3**  
**SCHRITT 3**  
**ÉTAPE 3**  
**PASSO 3**  
**PASO 3**

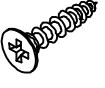
(E)	X12
	
Ø3.5*14	

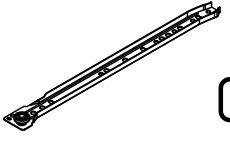
(N)	X1
	
L=350	

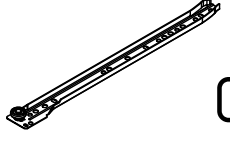
(N)	X3
	
L=350	

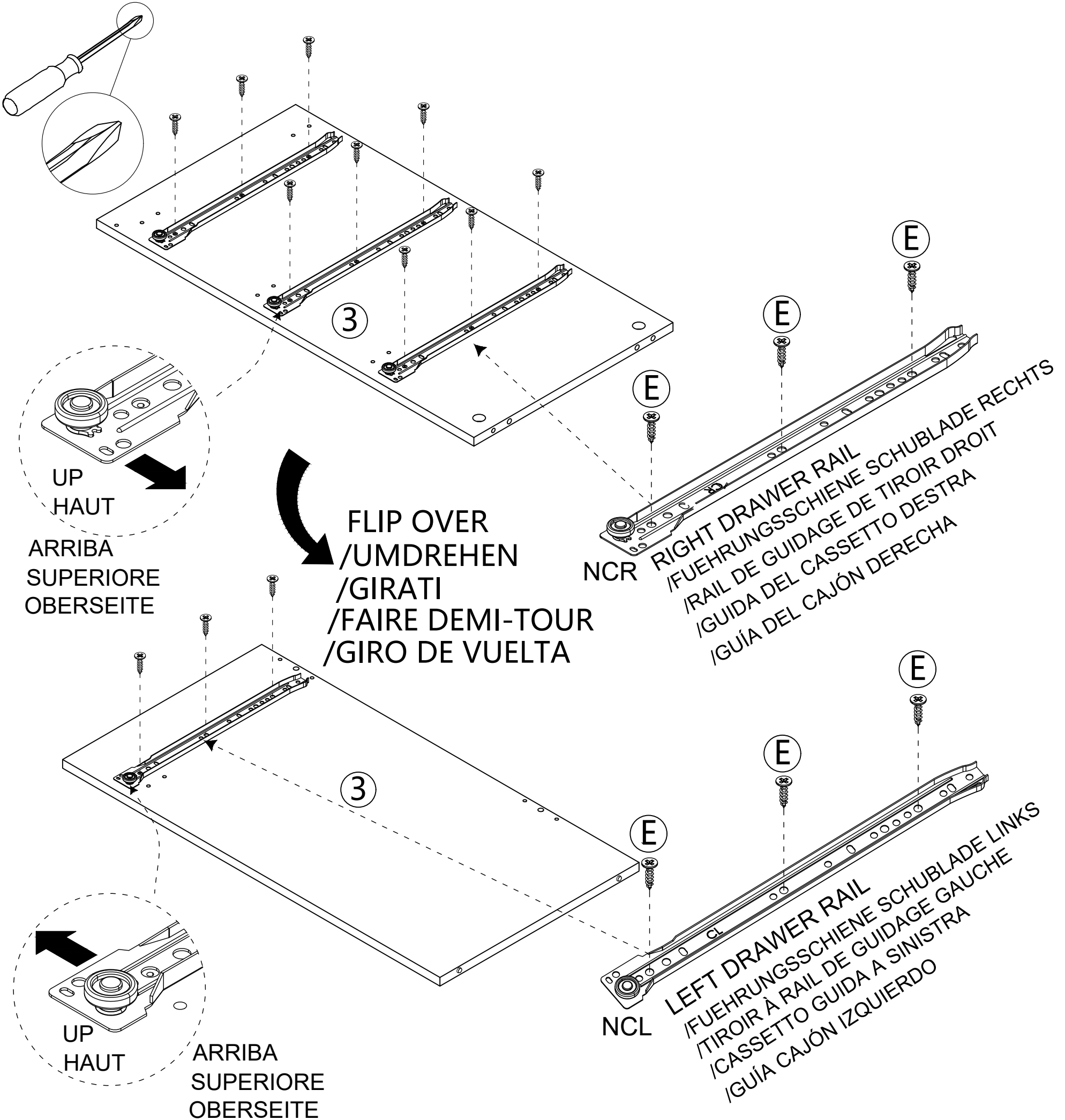

STEP 4  
SCHRITT 4  
ÉTAPE 4  
PASSO 4  
PASO 4

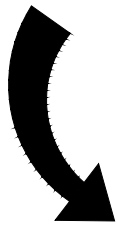
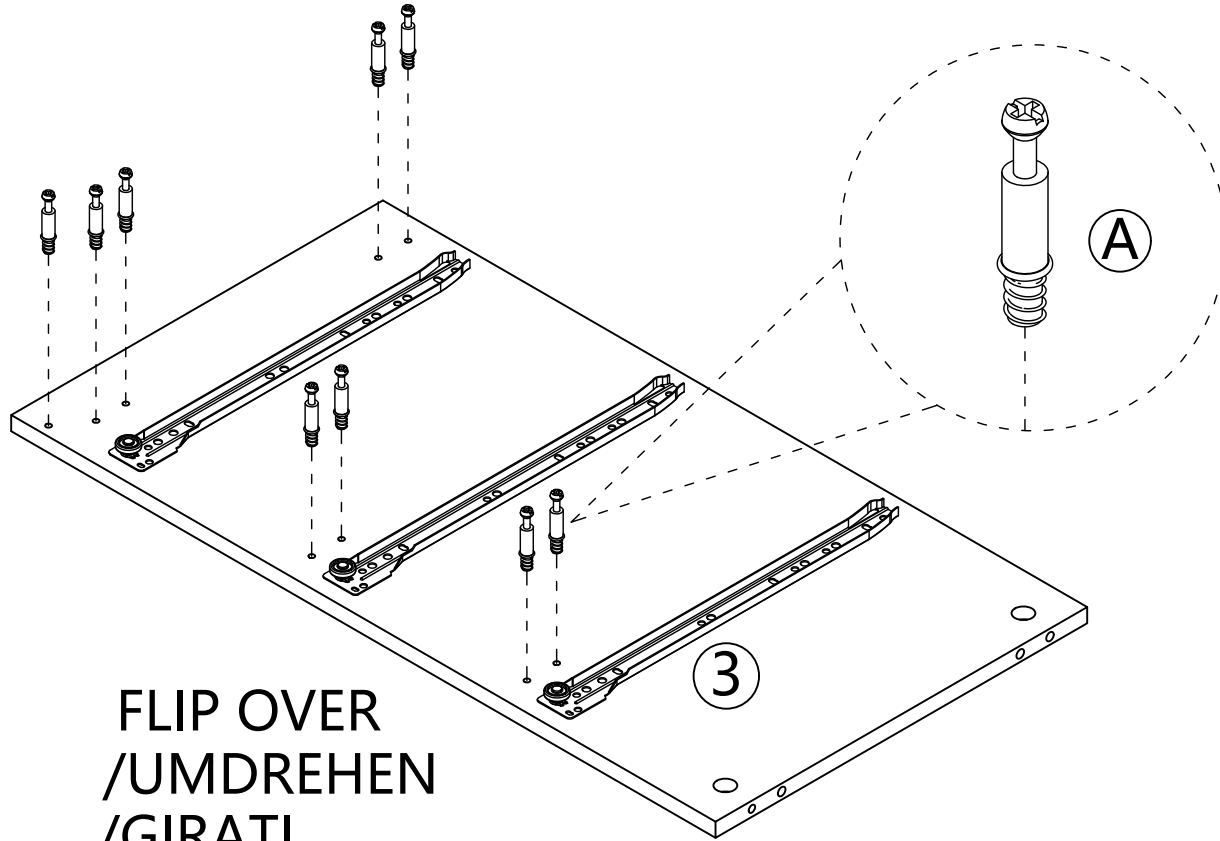
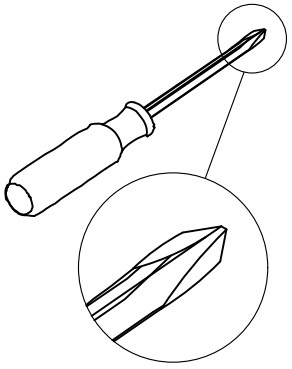
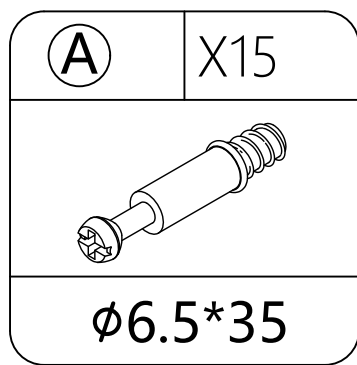

FLIP OVER  
/UMDREHEN  
/GIRATI  
/FAIRE DEMI-TOUR  
/GIRO DE VUELTA

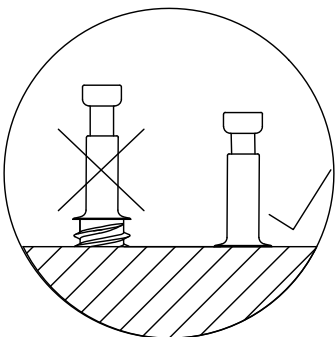
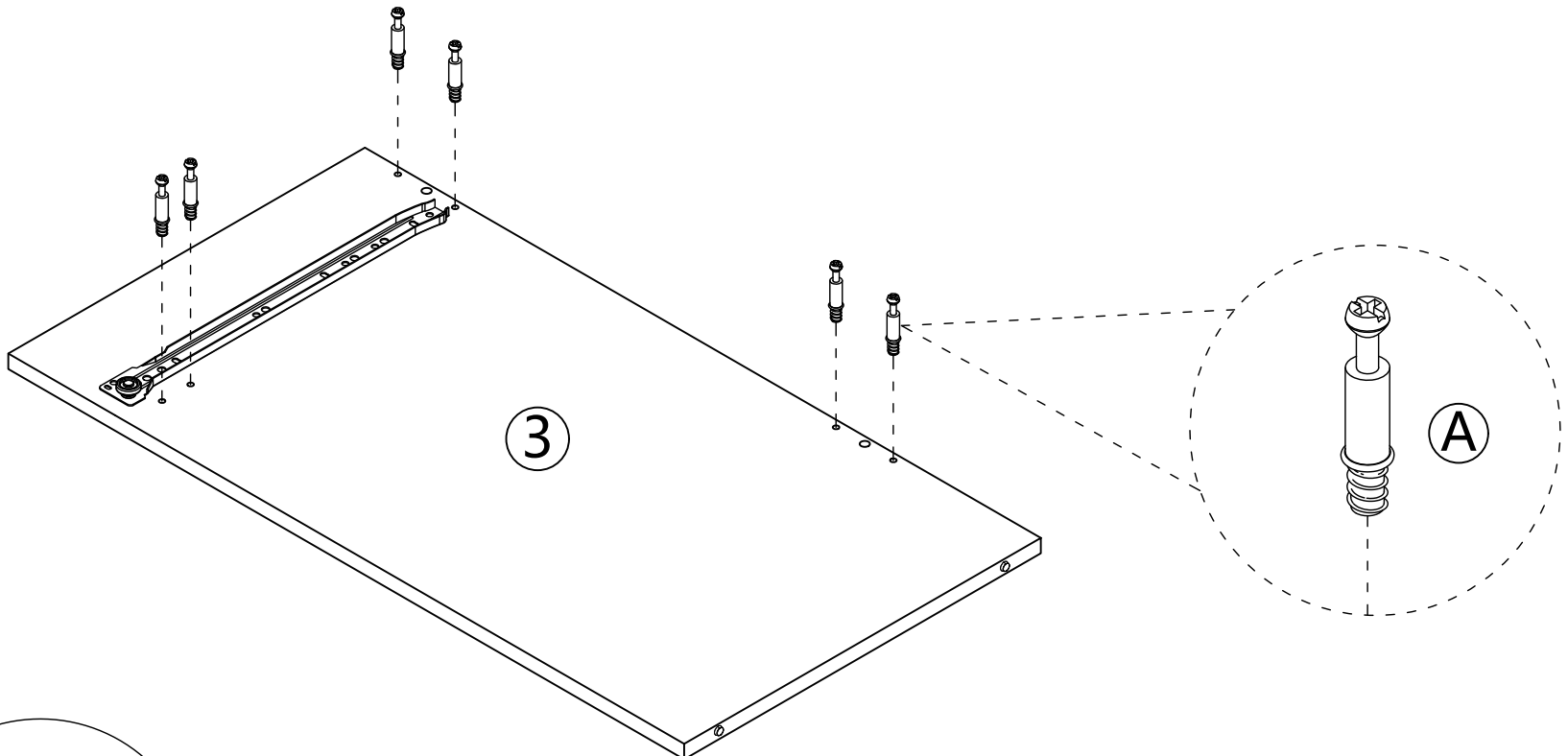

STEP 5  
 SCHRITT 5  
 ÉTAPE 5  
 PASSO 5  
 PASO 5

(E)	X12
	
Ø3.5*14	

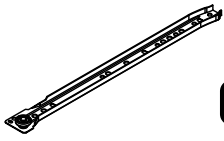
(N)	X3
	
CL	
L=350	

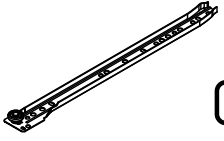
(N)	X1
	
CR	
L=350	

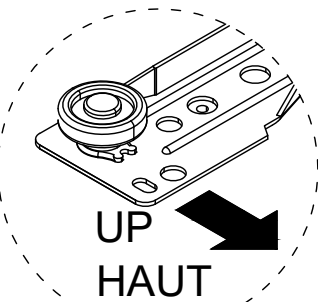
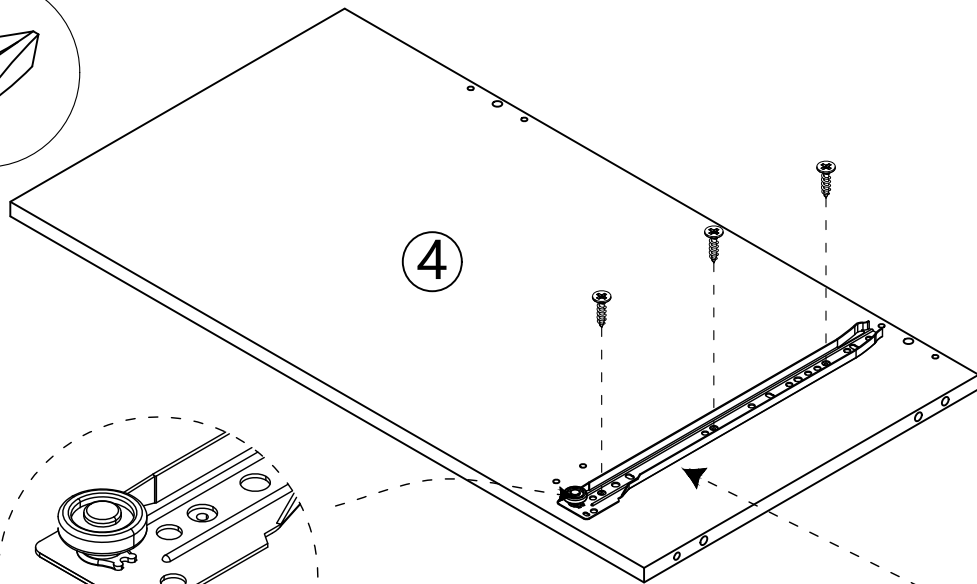
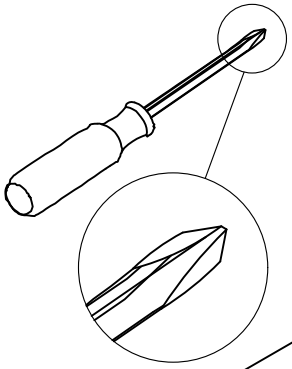

UP  
 HAUT  
 ARRIBA  
 SUPERIORE  
 OBERSEITE

FLIP OVER  
 /UMDREHEN  
 /GIRATI  
 /FAIRE DEMI-TOUR  
 /GIRO DE VUELTA

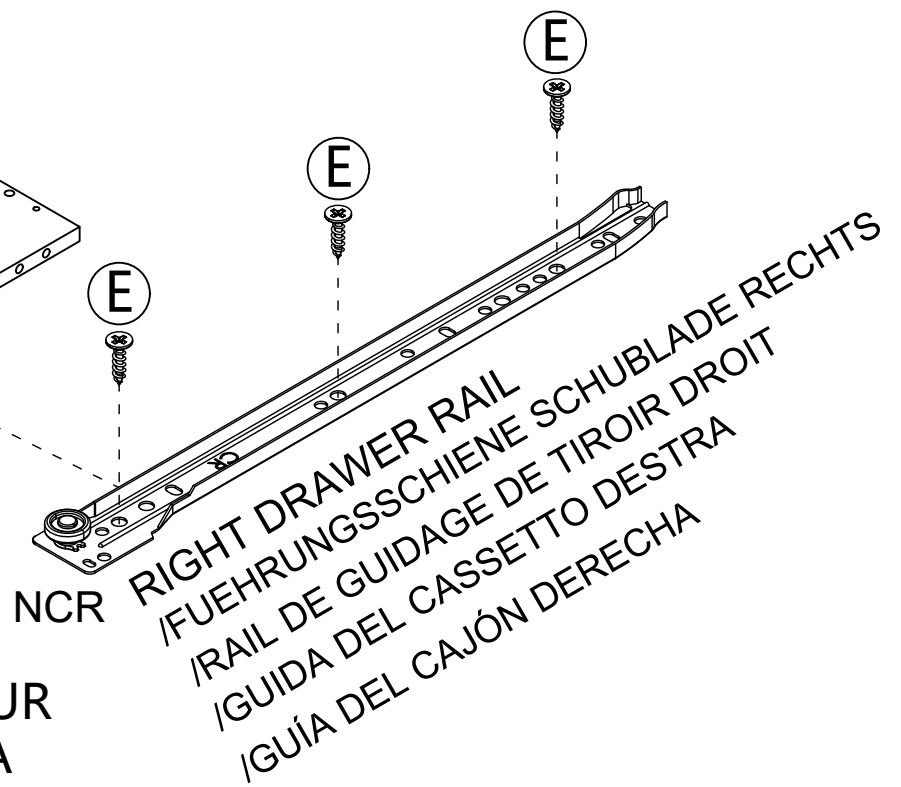

NCR RIGHT DRAWER RAIL  
 /FUEHRUNGSSCHIENE SCHUBLADE RECHTS  
 /RAIL DE GUIDAGE DE TIROIR DROIT  
 /GUIDA DEL CASSETTO DESTRA  
 /GUÍA DEL CAJÓN DERECHA

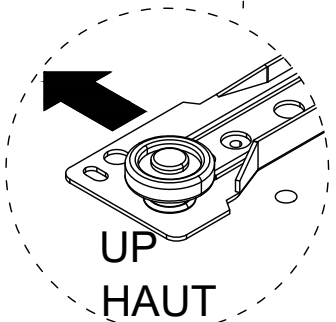
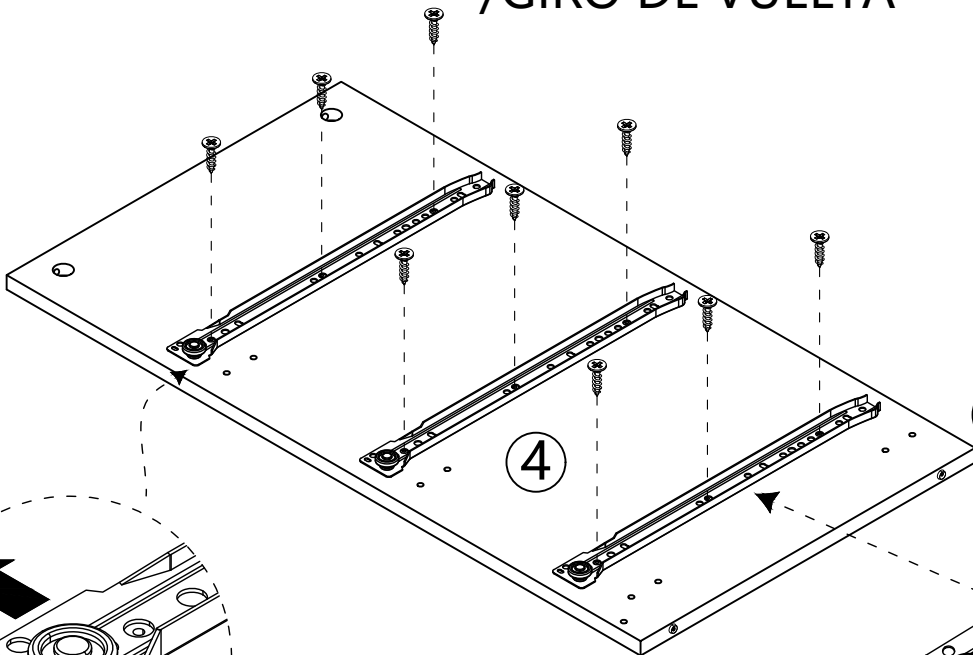

UP  
 HAUT  
 ARRIBA  
 SUPERIORE  
 OBERSEITE

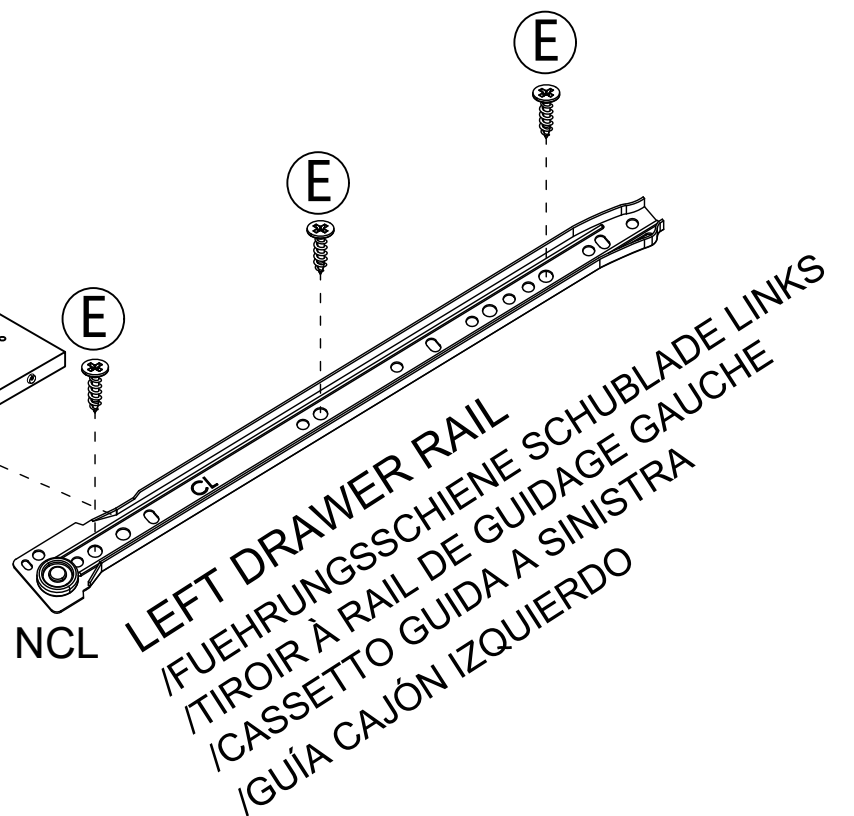

NCL LEFT DRAWER RAIL  
 /FUEHRUNGSSCHIENE SCHUBLADE LINKS  
 /TIROIR À RAIL DE GUIDAGE GAUCHE  
 /CASSETTO GUIDA A SINISTRA  
 /GUÍA CAJÓN IZQUIERDO

STEP 6  
SCHRITT 6  
ÉTAPE 6  
PASSO 6  
PASO 6

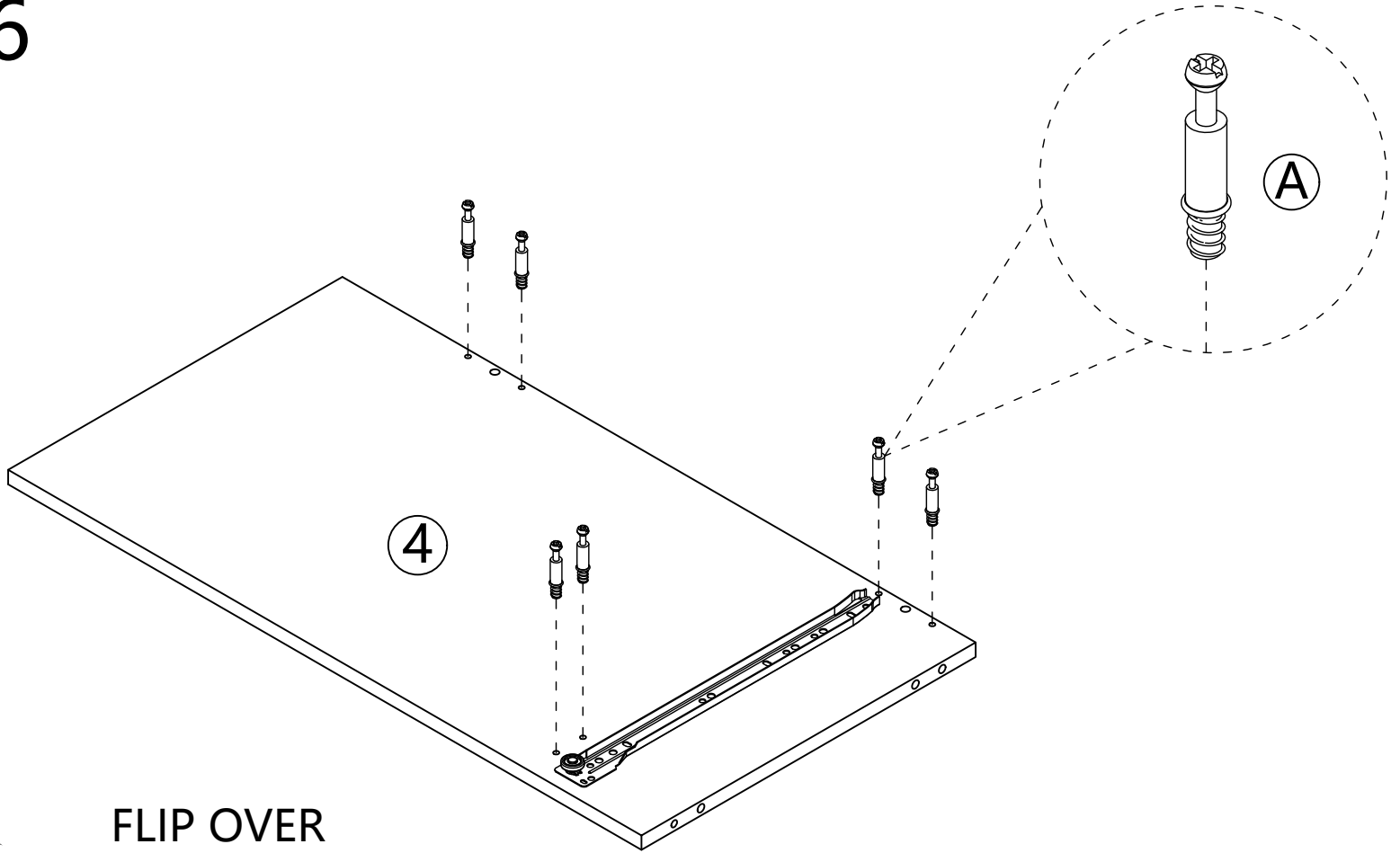
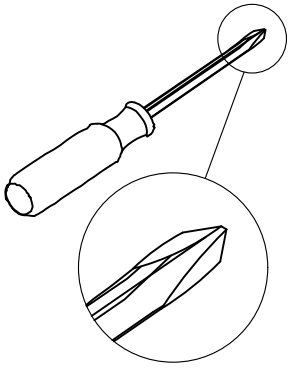
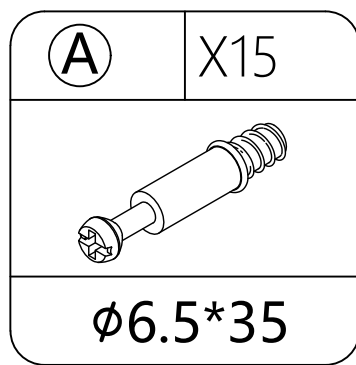

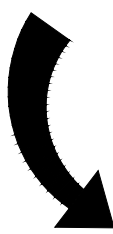
 FLIP OVER  
/UMDREHEN  
/GIRATI  
/FAIRE DEMI-TOUR  
/GIRO DE VUELTA

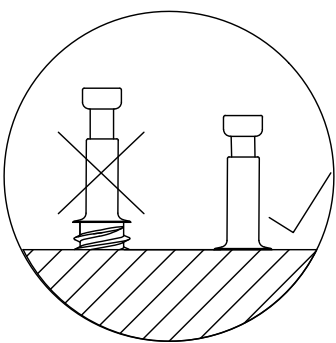
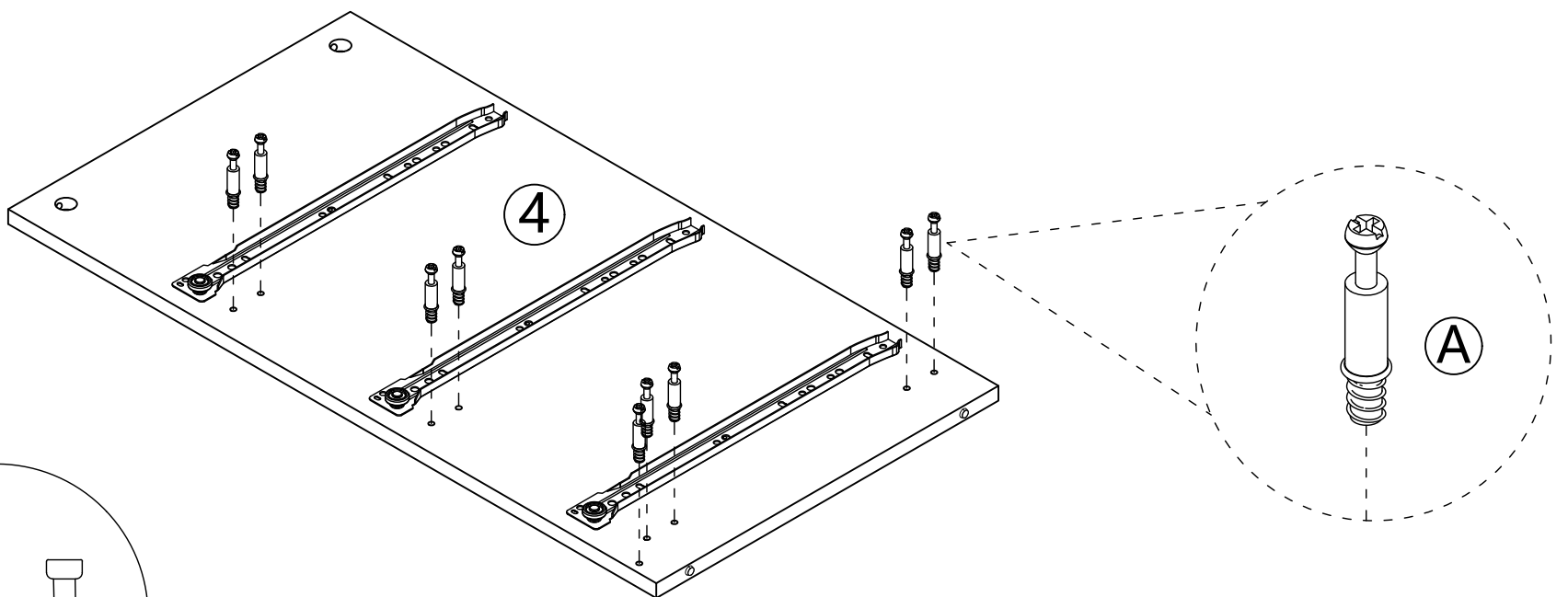

# STEP 7

# SCHRITT 7

# ÉTAPE 7

# PASSO 7

# PASO 7

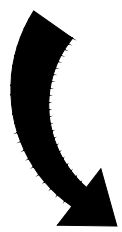
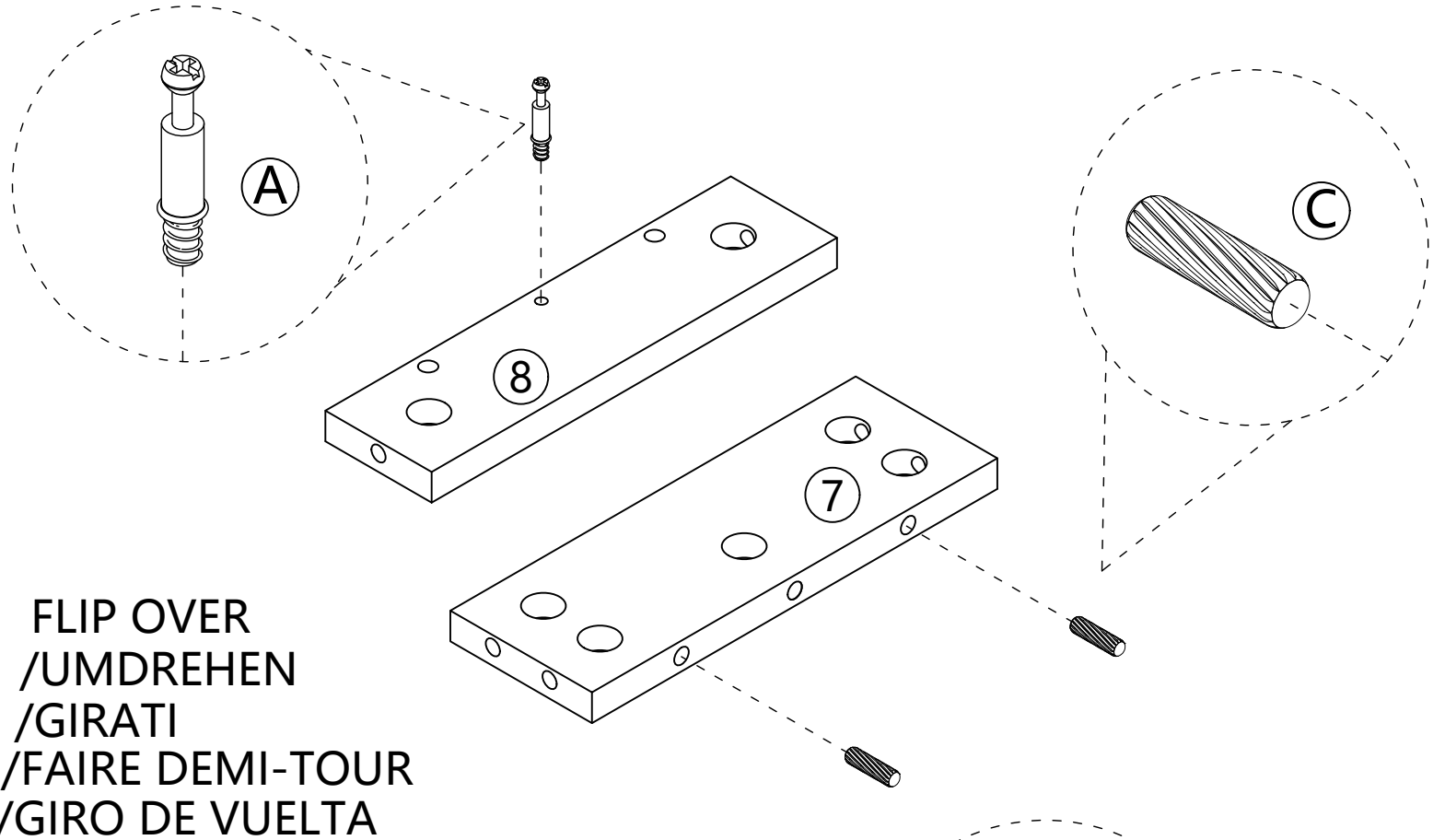
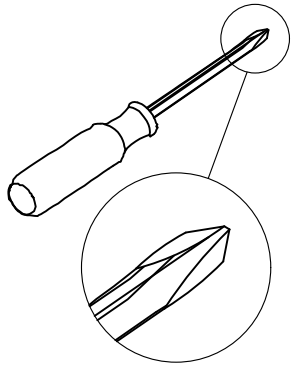
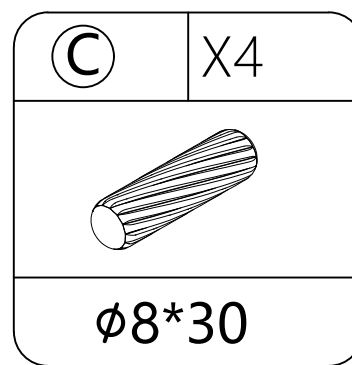
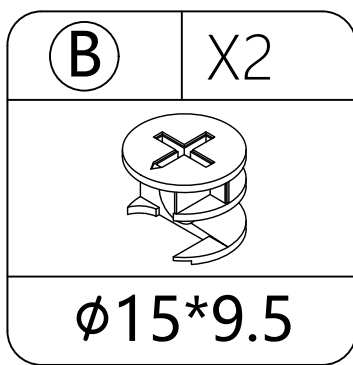
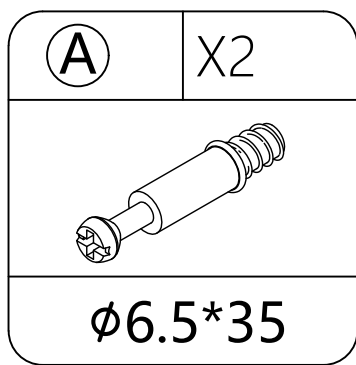

FLIP OVER  
/UMDREHEN  
/GIRATI  
/FAIRE DEMI-TOUR  
/GIRO DE VUELTA

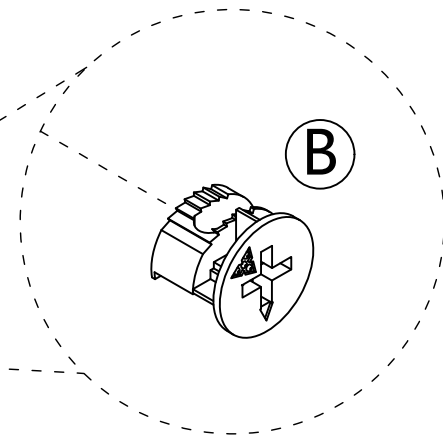
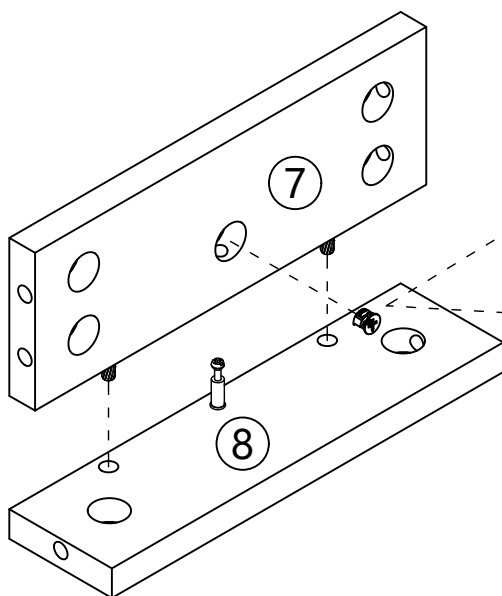
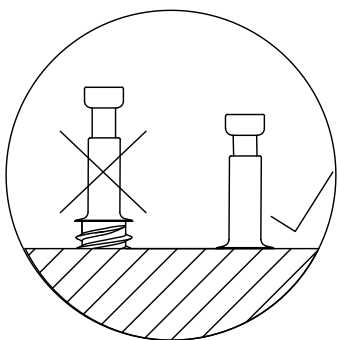

# X 2

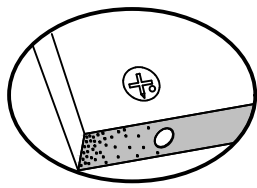
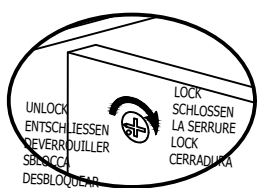

Proper orientation of CAM LOCK  
/Richtige Ausrichtung des CAM LOCK  
/La bonne orientation du verrou à came  
/Orientamento corretto del CAM LOCK  
/La dirección correcta de la cerradura de la Cámara

INSERT THE CAM BOLT INTO THE HOLE FIRST, THEN INSERT THE CAM LOCK AND FASTEN IT.  
/FUEHREN SIE ZUERST DEN NOCKENBOLZEN IN DAS BOHRLOCH EIN, ANSCHLIESSEND STECKEN SIE DEN HALTENOCKEN IN DIE DAFUER VORGESEHEN OEFFNUNG UND ZIEHEN IHN AN.  
/INSÉREZ D'ABORD LE BOULON À CAME DANS LE TROU DE PERÇAGE, PUIS INSÉREZ LA CAME DE MAINTIEN DANS L'OUVERTURE PRÉVUE À CELLE-CI ET SERREZ-LA.  
/INSERIRE PRIMA IL BULLONE DELLA CAMMA NEL FORO, POI INSERIRE LA CAMMA DI FISSAGGIO NELL'APERTURA PREVISTA E SERRARE.  
/PRIMERO INSERTE EL PERNO DE LEVA EN EL ORIFICIO DE PERFORACIÓN, LUEGO INSERTE LA LEVA DE SUJECIÓN EN LA ABERTURA PROPORCIONADA PARA ELLO Y APRIETE.

# STEP 8

## SCHRITT 8

### ÉTAPE 8

### PASSO 8

### PASO 8

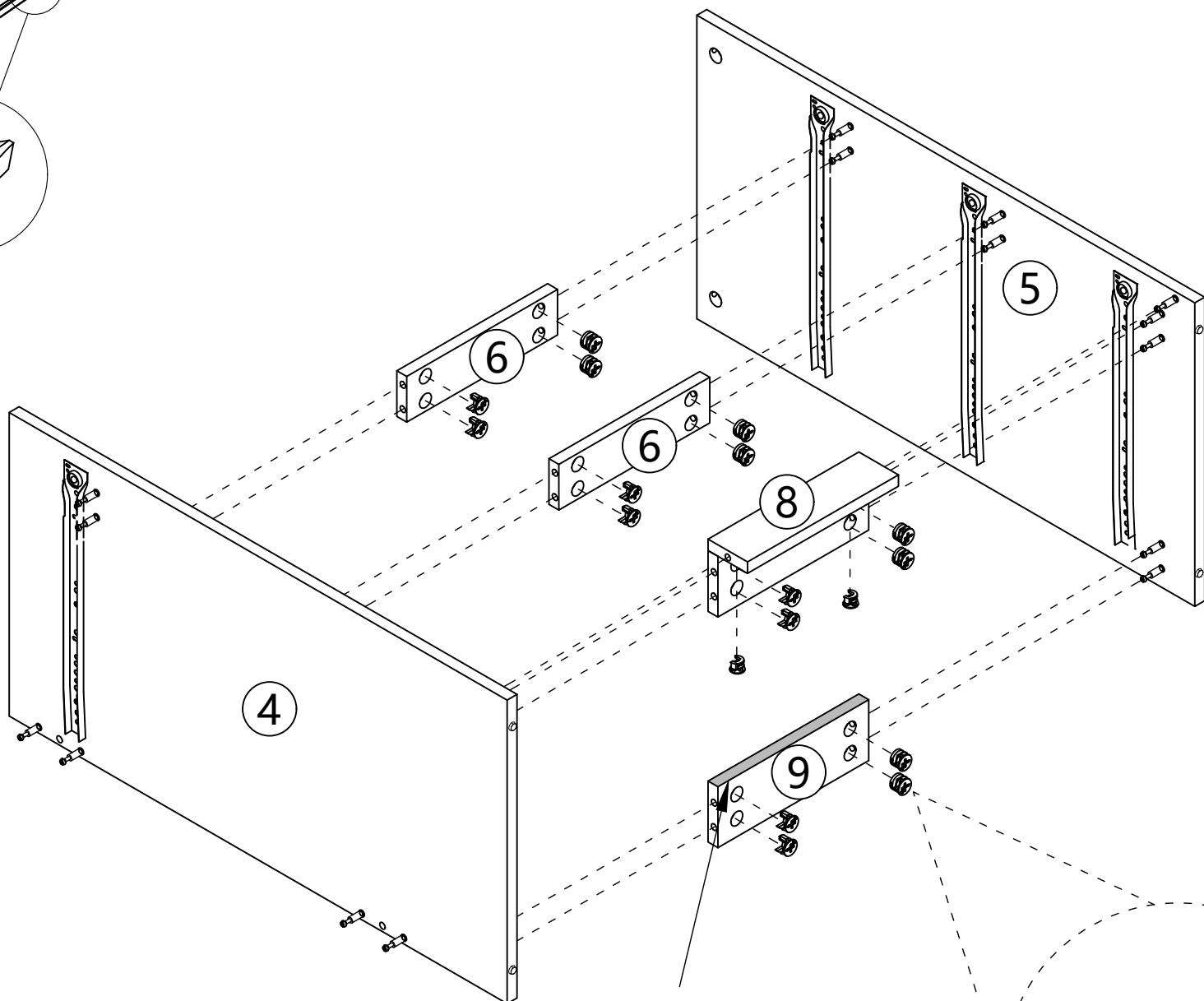
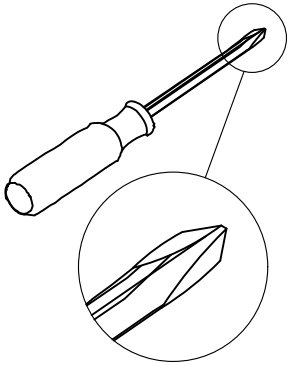
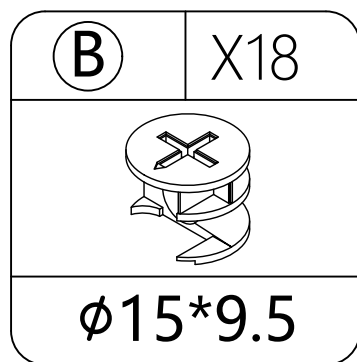

EDGE WITHOUT FINISHING  
 /OFFENE KANTE  
 /BORD OUVERT  
 /BORDO APERTO  
 /BORDE ABIERTO

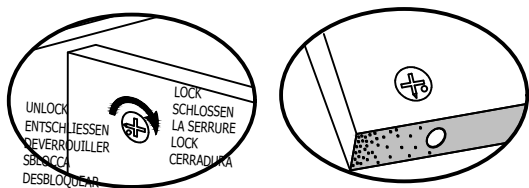
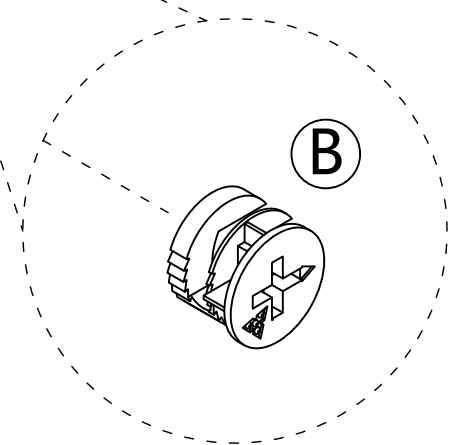

Proper orientation of CAM LOCK  
 /Richtige Ausrichtung des CAM LOCK  
 /La bonne orientation du verrou à came  
 /Orientamento corretto del CAM LOCK  
 /La dirección correcta de la cerradura de la Cámara

INSERT THE CAM BOLT INTO THE HOLE FIRST, THEN INSERT THE CAM LOCK AND FASTEN IT.  
 /FUEHREN SIE ZUERST DEN NOCKENBOLZEN IN DAS BOHRLOCH EIN, ANSCHLIESSEND STECKEN SIE DEN HALTENOCKEN IN DIE DAFUER VORGESEHEN OEFFNUNG UND ZIEHEN IHN AN.  
 /INSÉREZ D'ABORD LE BOULON À CAME DANS LE TROU DE PERÇAGE, PUIS INSÉREZ LA CAME DE MAINTIEN DANS L'OUVERTURE PRÉVUE À CELLE-CI ET SERREZ-LA.  
 /INSERIRE PRIMA IL BULLONE DELLA CAMMA NEL FORO, POI INSERIRE LA CAMMA DI FISSAGGIO NELL'APERTURA PREVISTA E SERRARE.  
 /PRIMERO INSERTE EL PERNO DE LEVA EN EL ORIFICIO DE PERFORACIÓN, LUEGO INSERTE LA LEVA DE SUJECIÓN EN LA ABERTURA PROPORCIONADA PARA ELLO Y APRIETE.

# STEP 9

# SCHRITT 9

# ÉTAPE 9

# PASSO 9

# PASO 9

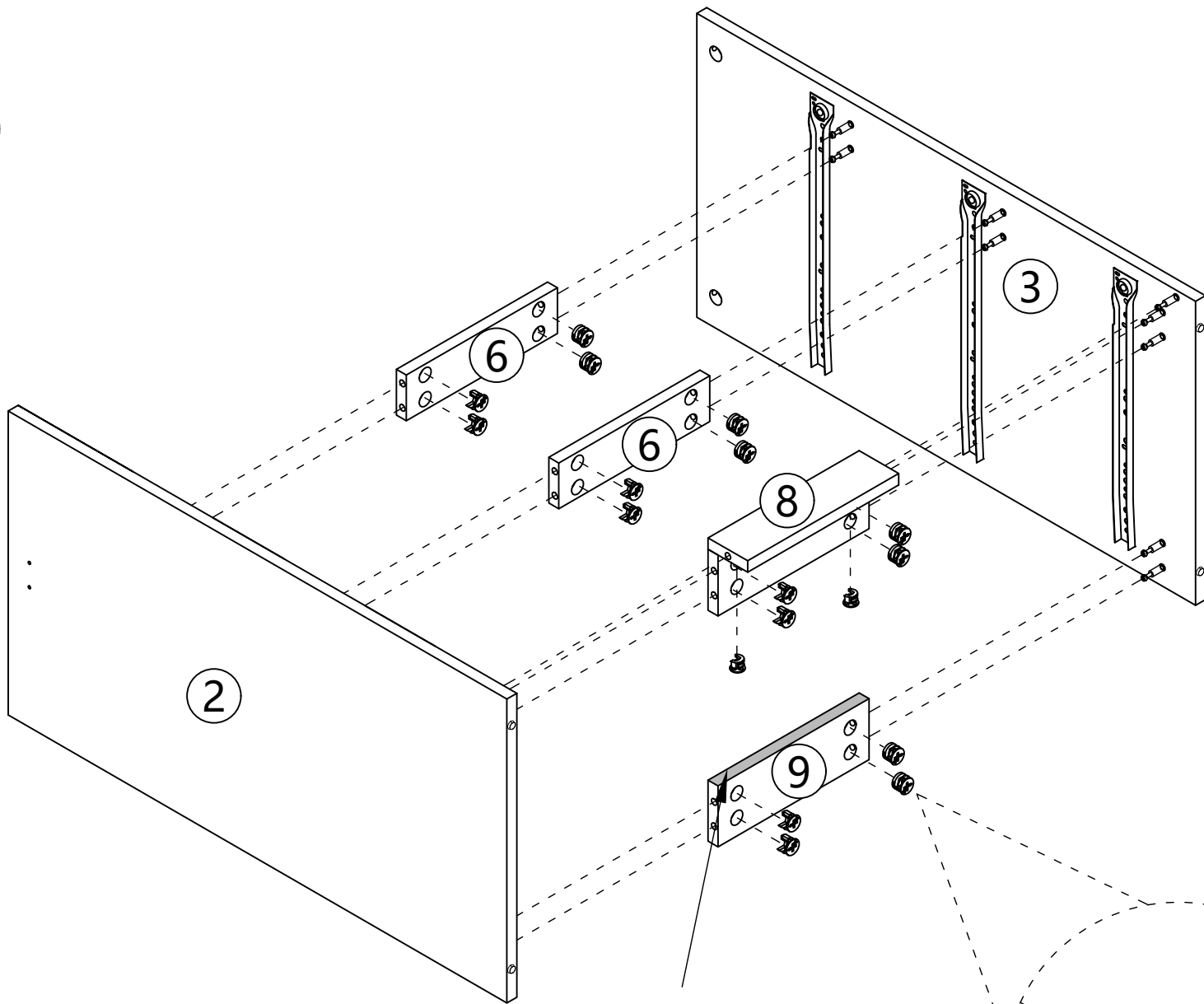
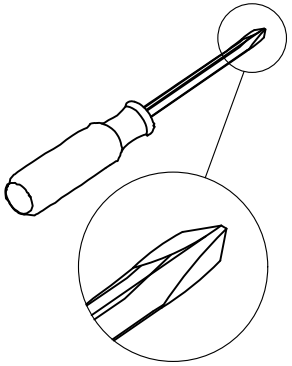
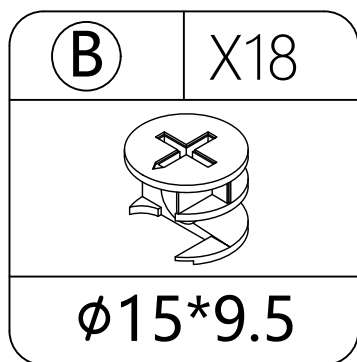

EDGE WITHOUT FINISHING  
 /OFFENE KANTE  
 /BORD OUVERT  
 /BORDO APERTO  
 /BORDE ABIERTO

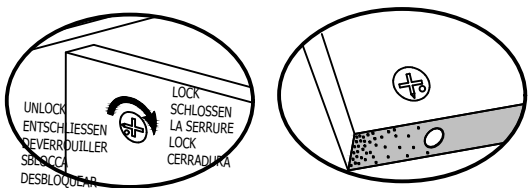
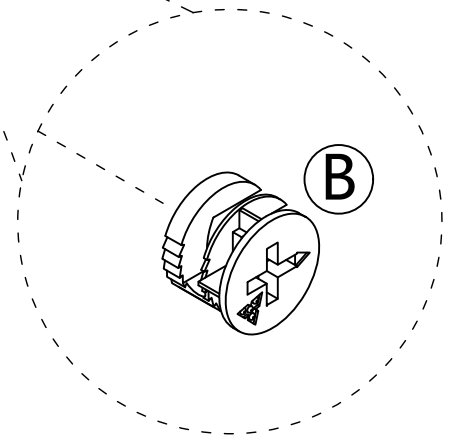

Proper orientation of CAM LOCK  
 /Richtige Ausrichtung des CAM LOCK  
 /La bonne orientation du verrou à came  
 /Orientamento corretto del CAM LOCK  
 /La dirección correcta de la cerradura de la Cámara

INSERT THE CAM BOLT INTO THE HOLE FIRST, THEN INSERT THE CAM LOCK AND FASTEN IT.  
 /FUEHREN SIE ZUERST DEN NOCKENBOLZEN IN DAS BOHRLOCH EIN, ANSCHLIESSEND STECKEN SIE DEN HALTENOCKEN IN DIE DAFUER VORGESEHEN OEFFNUNG UND ZIEHEN IHN AN.  
 /INSÉREZ D'ABORD LE BOULON À CAME DANS LE TROU DE PERÇAGE, PUIS INSÉREZ LA CAME DE MAINTIEN DANS L'OUVERTURE PRÉVUE À CELLE-CI ET SERREZ-LA.  
 /INSERIRE PRIMA IL BULLONE DELLA CAMMA NEL FORO, POI INSERIRE LA CAMMA DI FISSAGGIO NELL'APERTURA PREVISTA E SERRARE.  
 /PRIMERO INSERTE EL PERNO DE LEVA EN EL ORIFICIO DE PERFORACIÓN, LUEGO INSERTE LA LEVA DE SUJECIÓN EN LA ABERTURA PROPORCIONADA PARA ELLO Y APRIETE.

# STEP 10

## SCHRITT 10

### ÉTAPE 10

### PASSO 10

### PASO 10

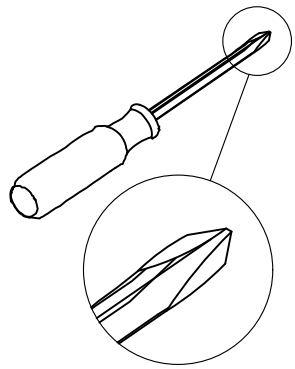
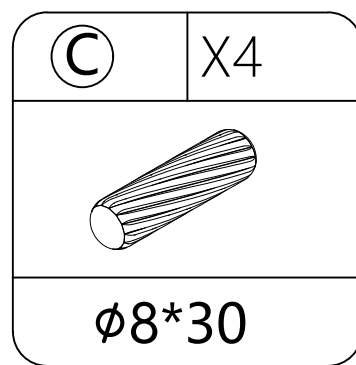
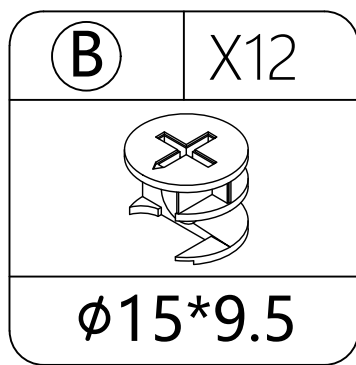

VENEERED EDGE  
/FURNIERTE KANTE  
/BORD PLAQUÉ  
/BORDO IMPIALLACCIATO  
/BORDE CHAPADO

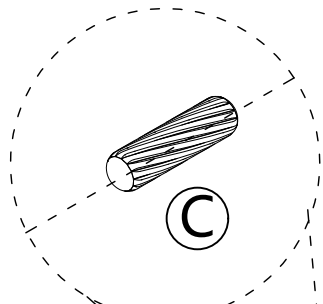

VENEERED EDGE  
/FURNIERTE KANTE  
/BORD PLAQUÉ  
/BORDO IMPIALLACCIATO  
/BORDE CHAPADO

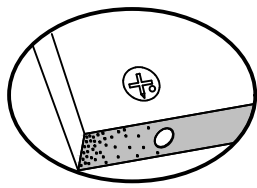
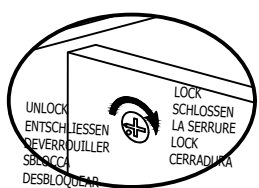
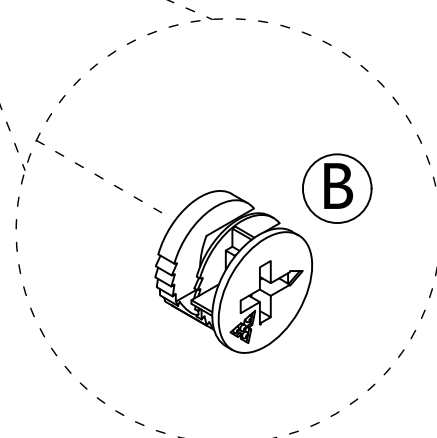
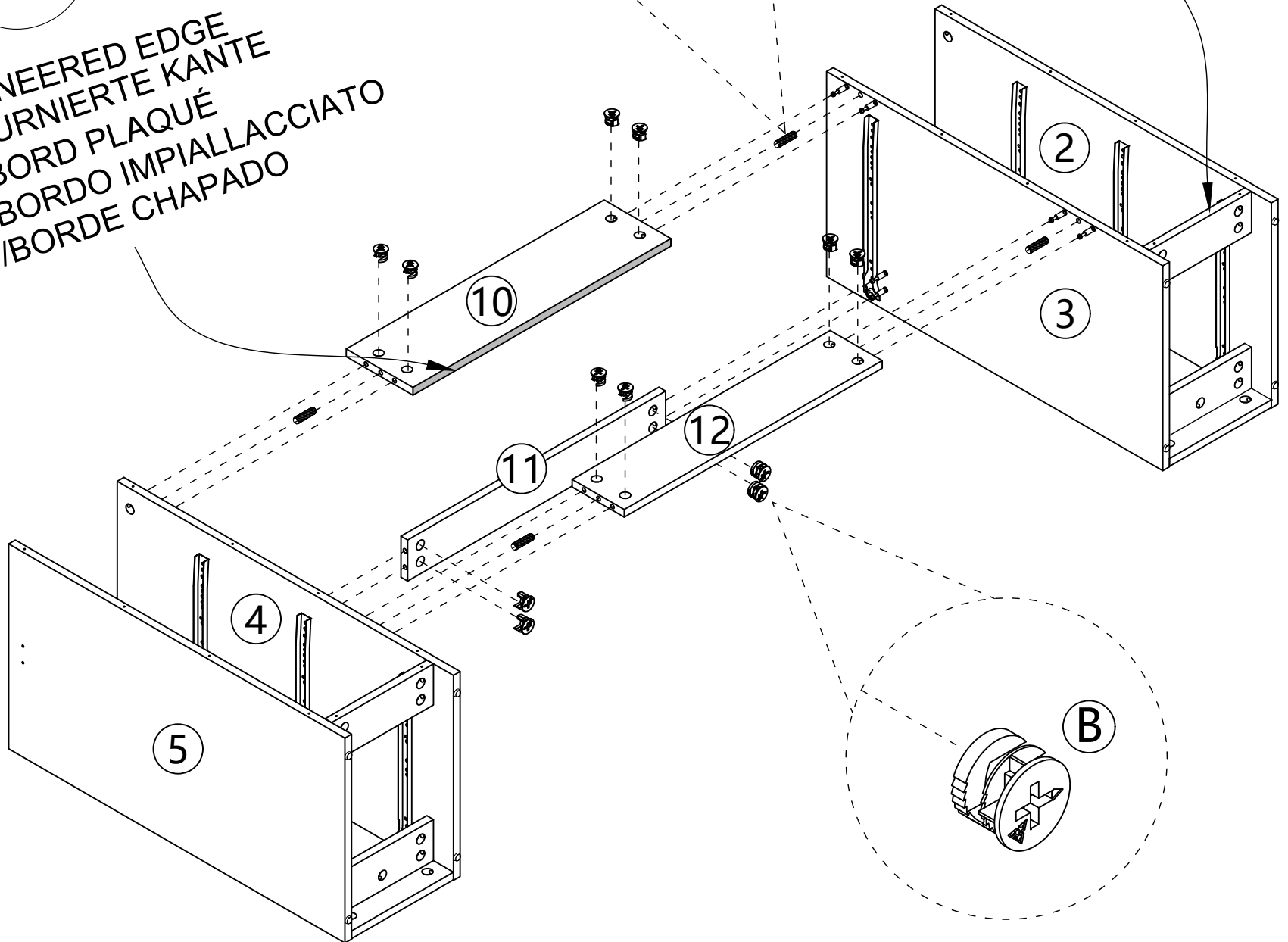

Proper orientation of CAM LOCK  
/Richtige Ausrichtung des CAM LOCK  
/La bonne orientation du verrou à came  
/Orientamento corretto del CAM LOCK  
/La dirección correcta de la cerradura de la Cámara

INSERT THE CAM BOLT INTO THE HOLE FIRST, THEN INSERT THE CAM LOCK AND FASTEN IT.  
/FUEHREN SIE ZUERST DEN NOCKENBOLZEN IN DAS BOHRLOCH EIN, ANSCHLIESSEND STECKEN SIE DEN HALTENOCKEN IN DIE DAFUER VORGESEHEN OEFFNUNG UND ZIEHEN IHN AN.  
/INSÉREZ D'ABORD LE BOULON À CAME DANS LE TROU DE PERÇAGE, PUIS INSÉREZ LA CAME DE MAINTIEN DANS L'OUVERTURE PRÉVUE À CELLE-CI ET SERREZ-LA.  
/INSERIRE PRIMA IL BULLONE DELLA CAMMA NEL FORO, POI INSERIRE LA CAMMA DI FISSAGGIO NELL'APERTURA PREVISTA E SERRARE.  
/PRIMERO INSERTE EL PERNO DE LEVA EN EL ORIFICIO DE PERFORACIÓN, LUEGO INSERTE LA LEVA DE SUJECIÓN EN LA ABERTURA PROPORCIONADA PARA ELLO Y APRIETE.

# STEP 11

# SCHRITT 11

# ÉTAPE 11

# PASSO 11

# PASO 11

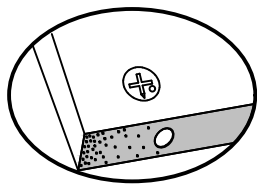
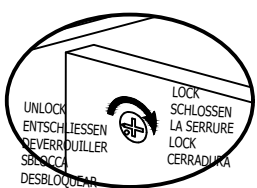
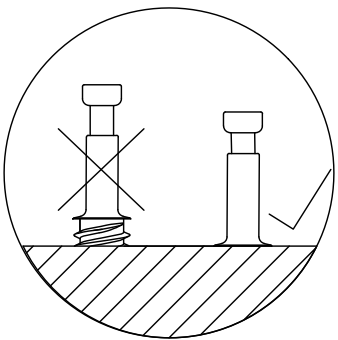
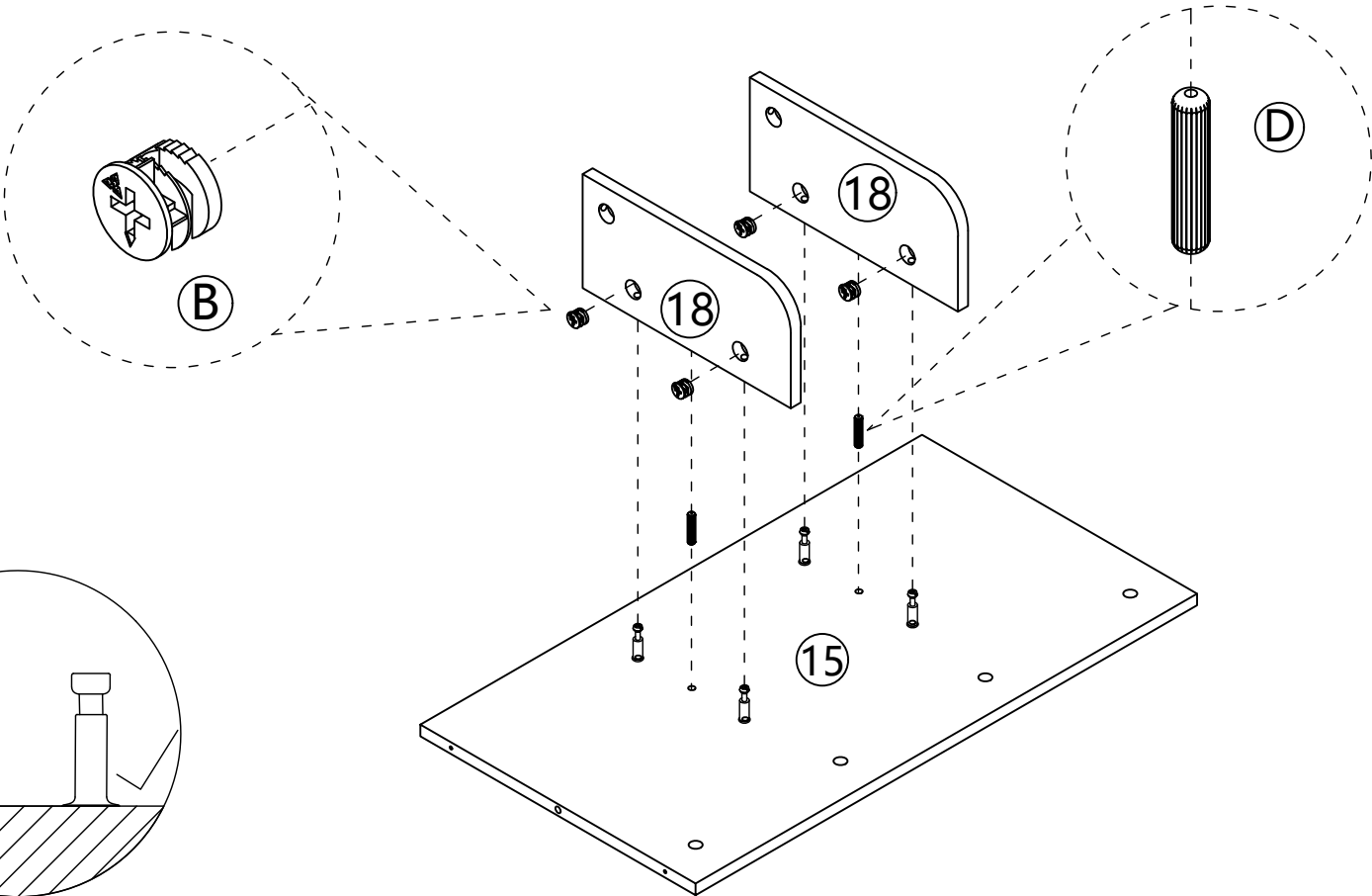
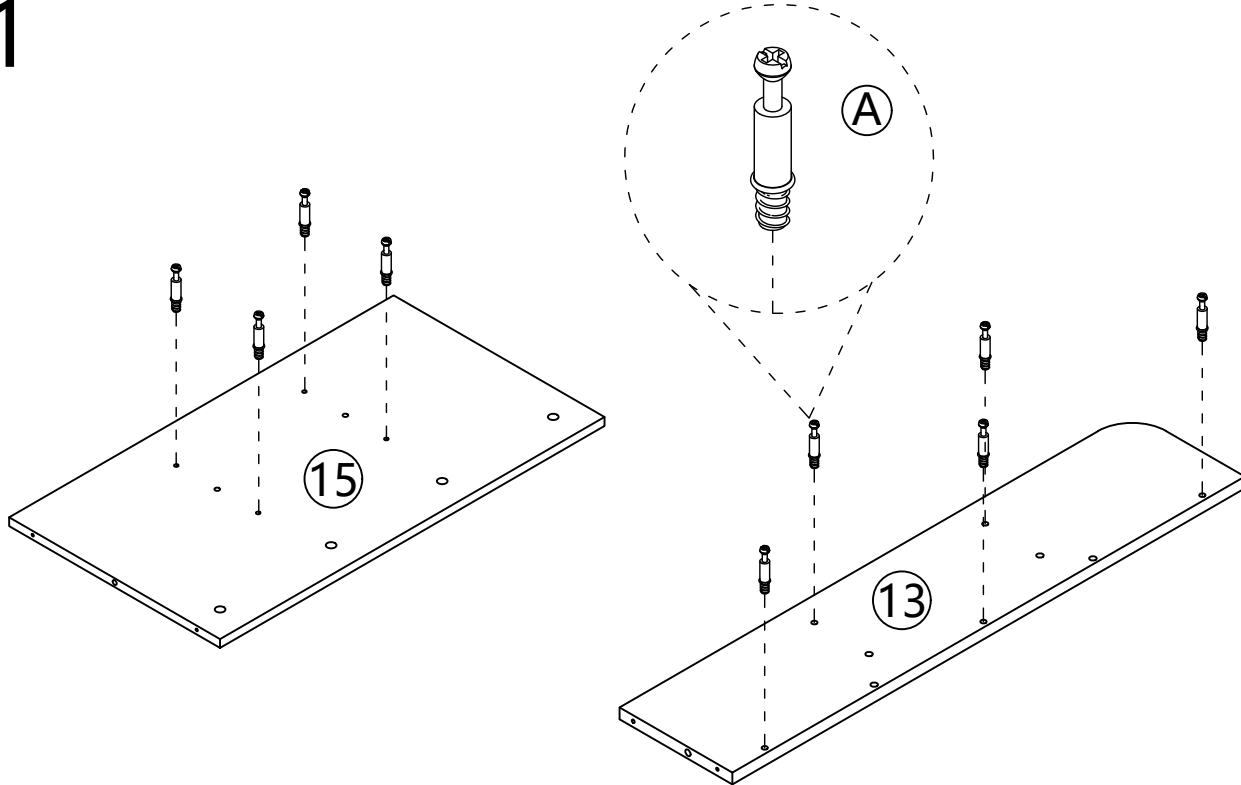
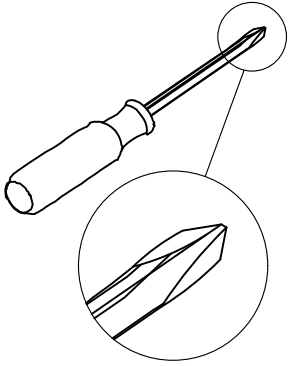
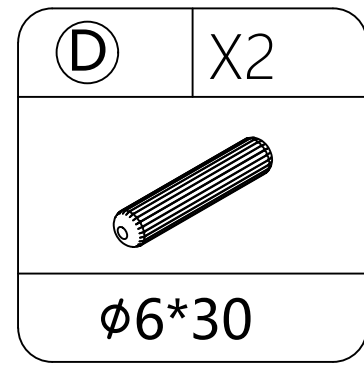
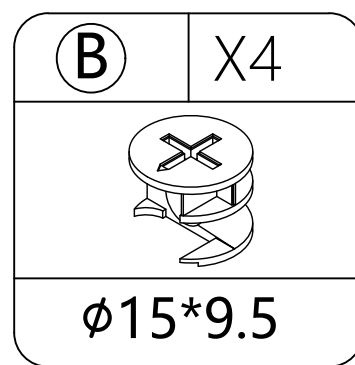
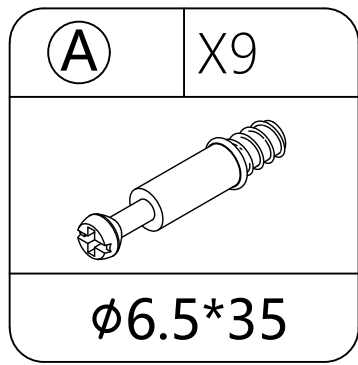

Proper orientation of CAM LOCK  
 /Richtige Ausrichtung des CAM LOCK  
 /La bonne orientation du verrou à came  
 /Orientamento corretto del CAM LOCK  
 /La dirección correcta de la cerradura de la Cámara

INSERT THE CAM BOLT INTO THE HOLE FIRST, THEN INSERT THE CAM LOCK AND FASTEN IT.  
 /FUEHREN SIE ZUERST DEN NOCKENBOLZEN IN DAS BOHRLOCH EIN, ANSCHLIESSEND STECKEN SIE DEN HALTENOCKEN IN DIE DAFUER VORGESEHEN OEFFNUNG UND ZIEHEN IHN AN.  
 /INSÉREZ D'ABORD LE BOULON À CAME DANS LE TROU DE PERÇAGE, PUIS INSÉREZ LA CAME DE MAINTIEN DANS L'OUVERTURE PRÉVUE À CELLE-CI ET SERREZ-LA.  
 /INSERIRE PRIMA IL BULLONE DELLA CAMMA NEL FORO, POI INSERIRE LA CAMMA DI FISSAGGIO NELL'APERTURA PREVISTA E SERRARE.  
 /PRIMERO INSERTE EL PERNO DE LEVA EN EL ORIFICIO DE PERFORACIÓN, LUEGO INSERTE LA LEVA DE SUJECIÓN EN LA ABERTURA PROPORCIONADA PARA ELLO Y APRIETE.

# STEP 12

# SCHRITT 12

# ÉTAPE 12

# PASSO 12

# PASO 12

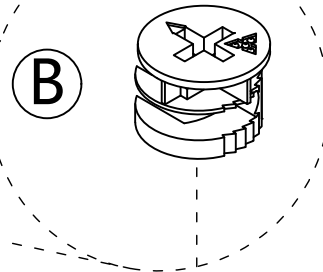
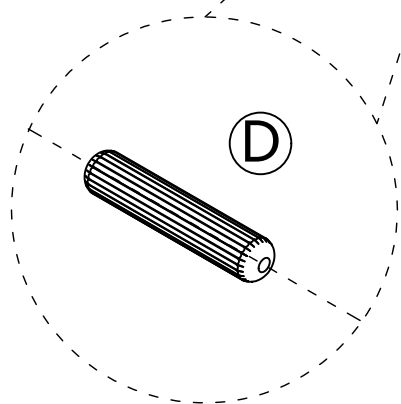
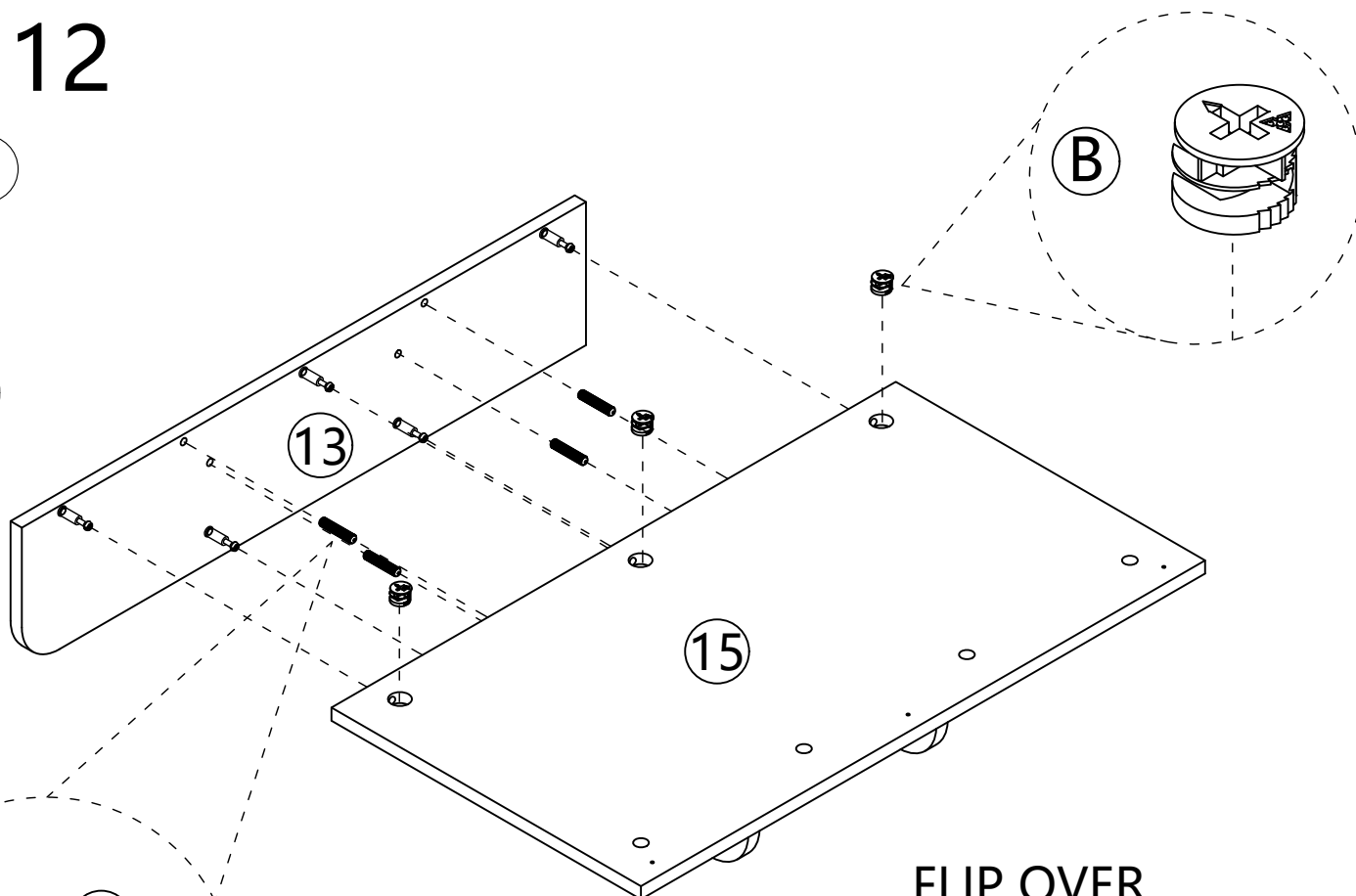
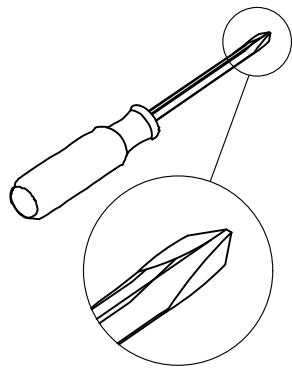
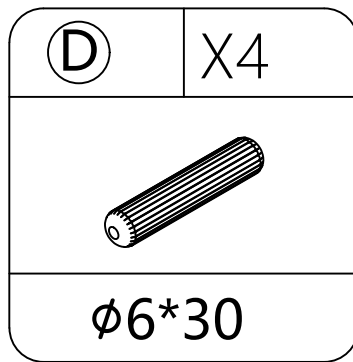
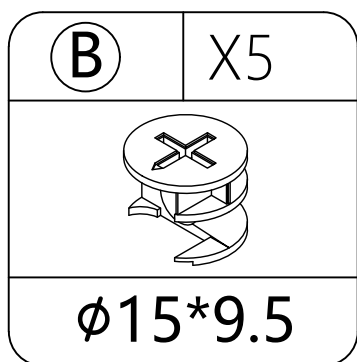

**FLIP OVER**  
**/UMDREHEN**  
**/GIRATI**  
**/FAIRE DEMI-TOUR**  
**/GIRO DE VUELTA**

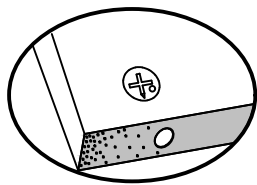
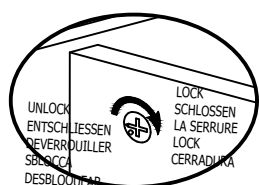
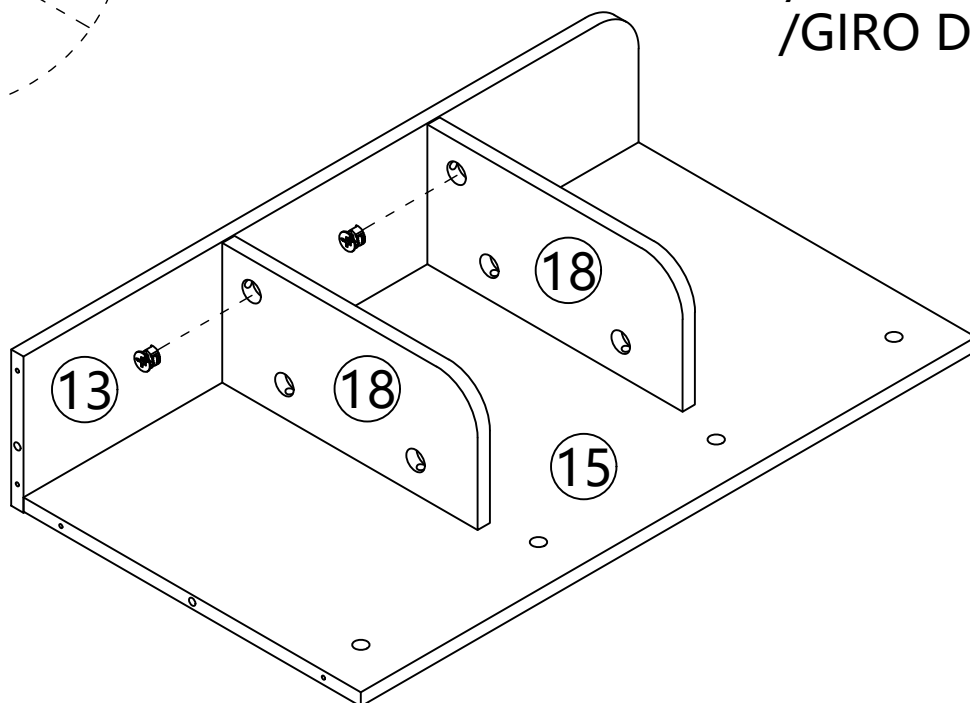
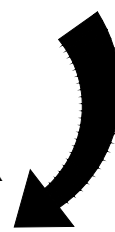

Proper orientation of CAM LOCK  
 /Richtige Ausrichtung des CAM LOCK  
 /La bonne orientation du verrou à came  
 /Orientamento corretto del CAM LOCK  
 /La dirección correcta de la cerradura de la Cámara

INSERT THE CAM BOLT INTO THE HOLE FIRST, THEN INSERT THE CAM LOCK AND FASTEN IT.  
 /FUEHREN SIE ZUERST DEN NOCKENBOLZEN IN DAS BOHRLOCH EIN, ANSCHLIESSEND STECKEN SIE DEN HALTENOCKEN IN DIE DAFUER VORGESEHEN OEFFNUNG UND ZIEHEN IHN AN.  
 /INSÉREZ D'ABORD LE BOULON À CAME DANS LE TROU DE PERÇAGE, PUIS INSÉREZ LA CAME DE MAINTIEN DANS L'OUVERTURE PRÉVUE À CELLE-CI ET SERREZ-LA.  
 /INSERIRE PRIMA IL BULLONE DELLA CAMMA NEL FORO, POI INSERIRE LA CAMMA DI FISSAGGIO NELL'APERTURA PREVISTA E SERRARE.  
 /PRIMERO INSERTE EL PERNO DE LEVA EN EL ORIFICIO DE PERFORACIÓN, LUEGO INSERTE LA LEVA DE SUJECIÓN EN LA ABERTURA PROPORCIONADA PARA ELLO Y APRIETE.

# STEP 13

## SCHRITT 13

### ÉTAPE 13

### PASSO 13

### PASO 13

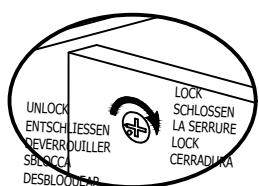
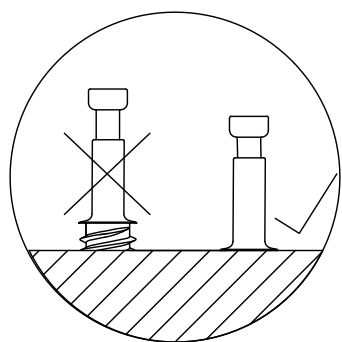
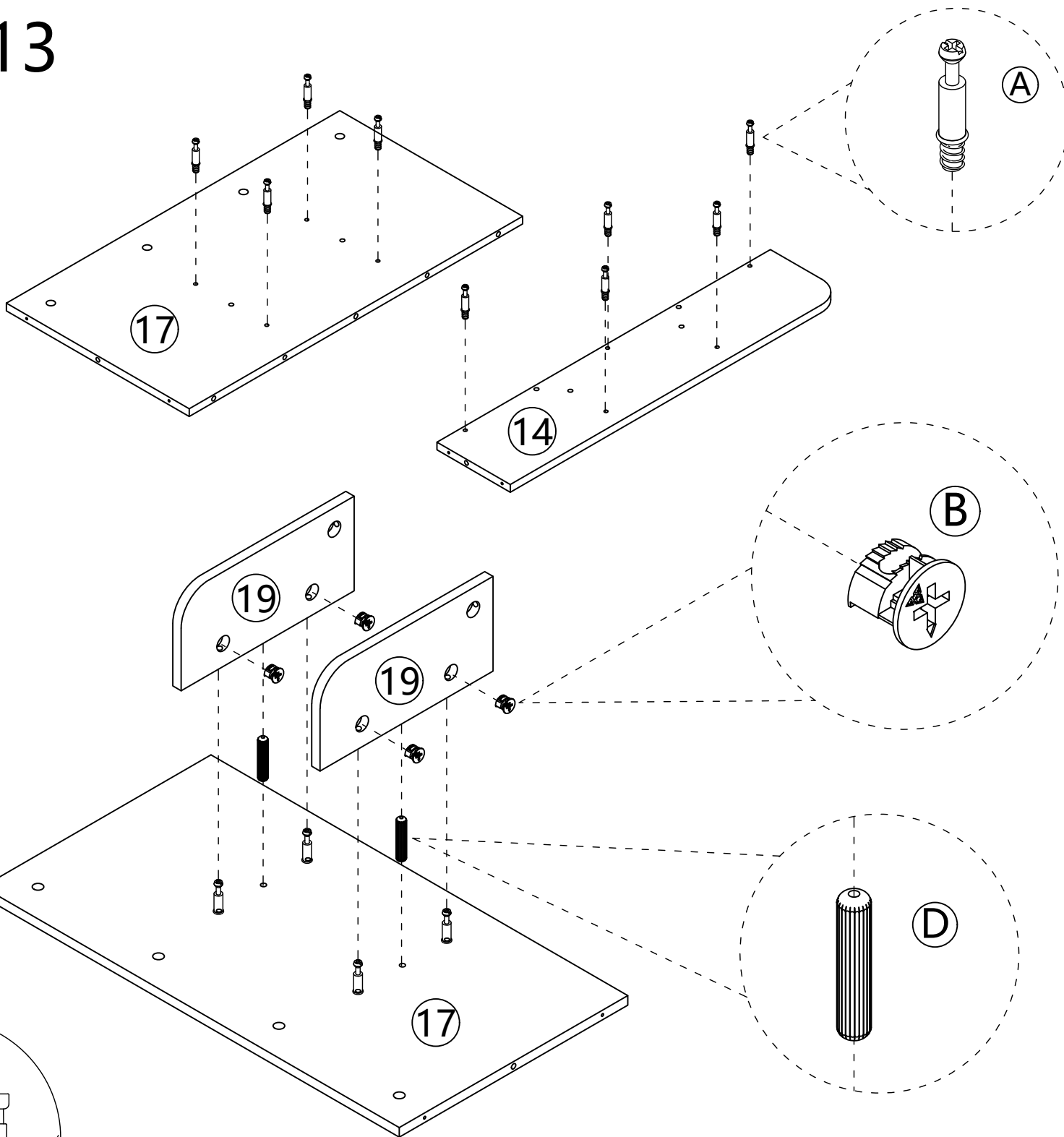
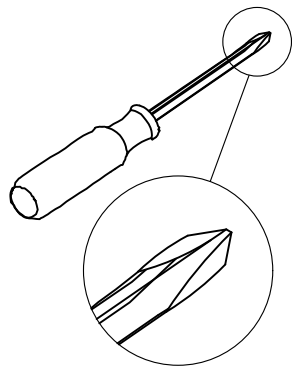
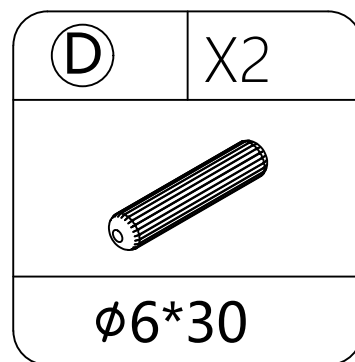
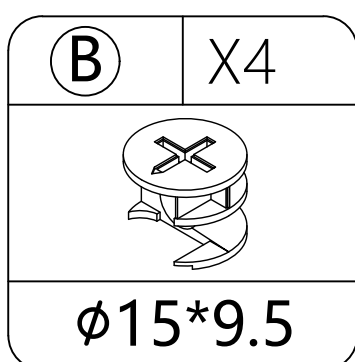
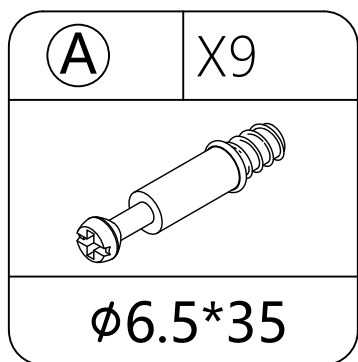

Proper orientation of CAM LOCK  
 /Richtige Ausrichtung des CAM LOCK  
 /La bonne orientation du verrou à came  
 /Orientamento corretto del CAM LOCK  
 /La dirección correcta de la cerradura de la Cámara

INSERT THE CAM BOLT INTO THE HOLE FIRST, THEN INSERT THE CAM LOCK AND FASTEN IT.  
 /FÜHREN SIE ZUERST DEN NOCKENBOLZEN IN DAS BOHRLOCH EIN, ANSCHLIESSEND STECKEN SIE DEN HALTENOCKEN IN DIE DAFUER VORGESEHEN OEFFNUNG UND ZIEHEN IHN AN.  
 /INSÉREZ D'ABORD LE BOULON À CAME DANS LE TROU DE PERÇAGE, PUIS INSÉREZ LA CAME DE MAINTIEN DANS L'OUVERTURE PRÉVUE À CELLE-CI ET SERREZ-LA.  
 /INSERIRE PRIMA IL BULLONE DELLA CAMMA NEL FORO, POI INSERIRE LA CAMMA DI FISSAGGIO NELL'APERTURA PREVISTA E SERRARE.  
 /PRIMERO INSERTE EL PERNO DE LEVA EN EL ORIFICIO DE PERFORACIÓN, LUEGO INSERTE LA LEVA DE SUJECIÓN EN LA ABERTURA PROPORCIONADA PARA ELLO Y APIRIETE.

# STEP 14

## SCHRITT 14

### ÉTAPE 14

### PASSO 14

### PASO 14

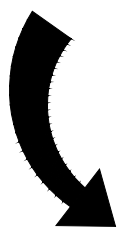
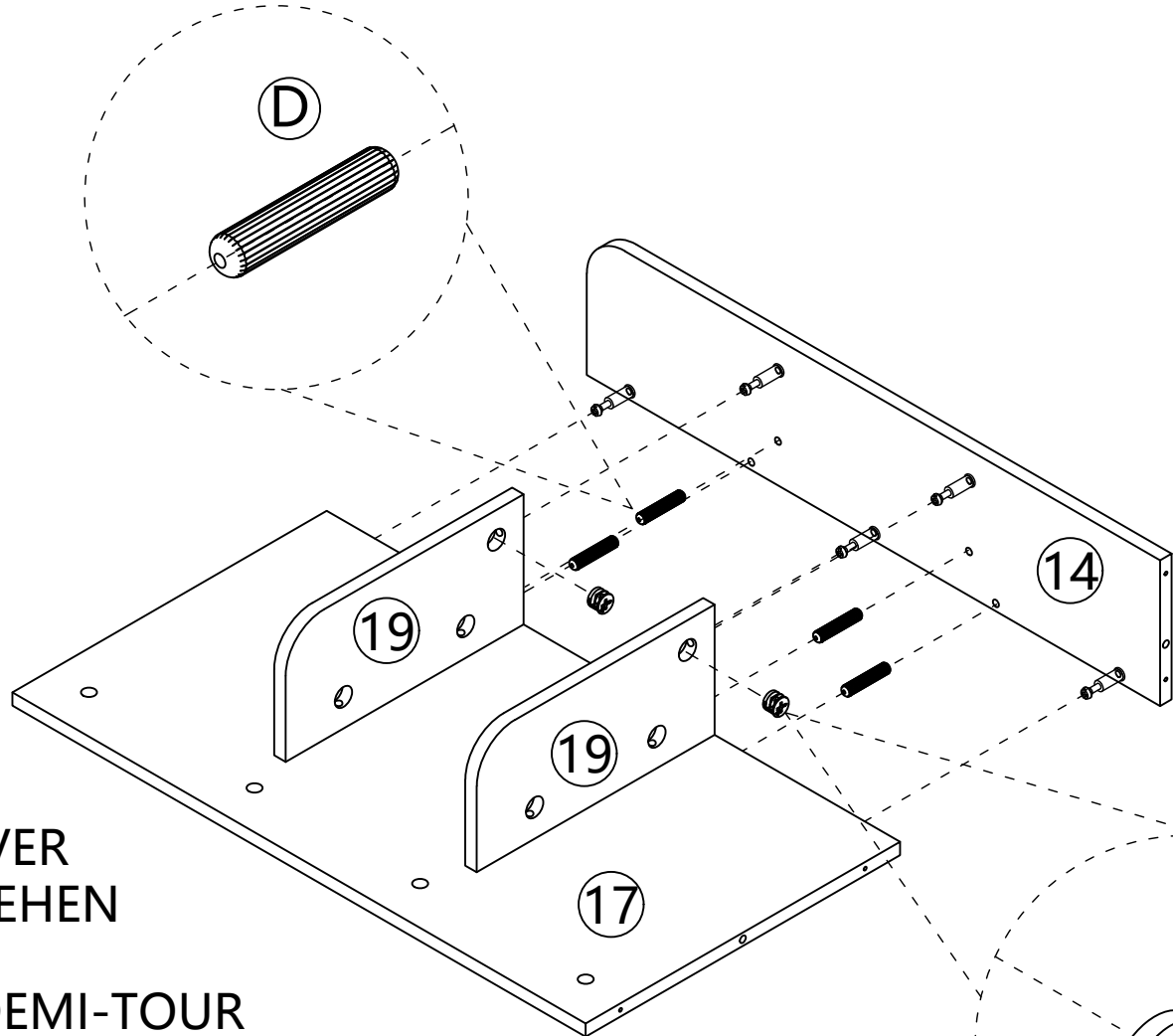
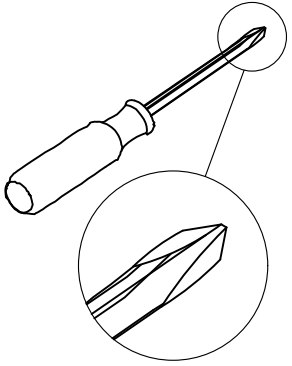
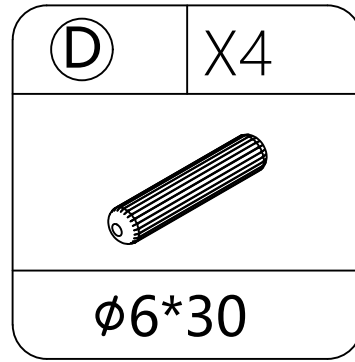
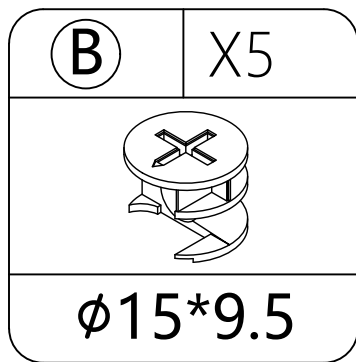

FLIP OVER  
/UMDREHEN  
/GIRATI  
/FAIRE DEMI-TOUR  
/GIRO DE VUELTA

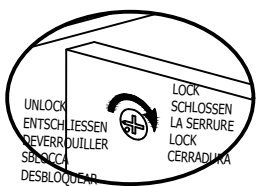
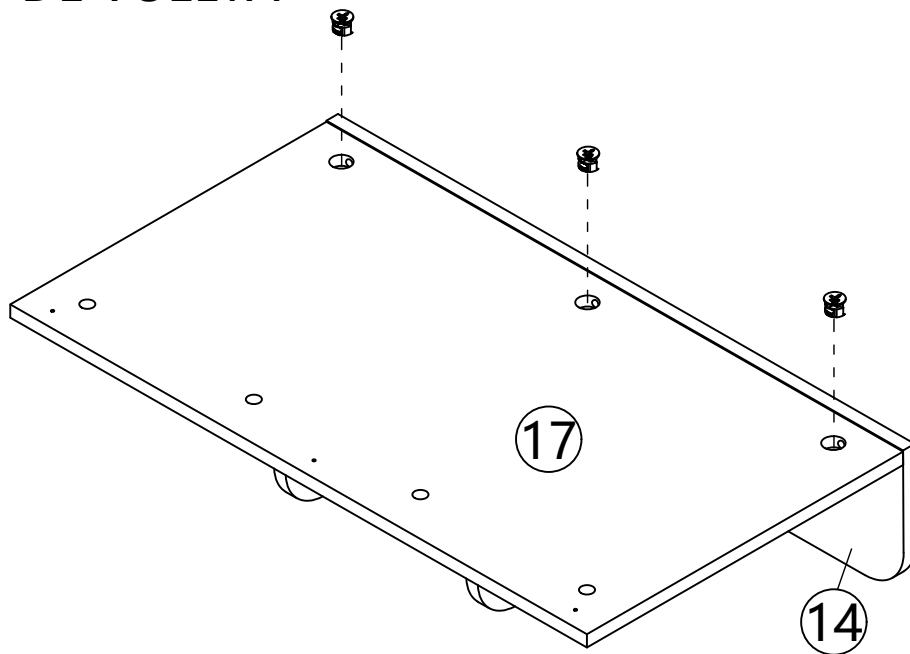

Proper orientation of CAM LOCK  
/Richtige Ausrichtung des CAM LOCK  
/La bonne orientation du verrou à came  
/Orientamento corretto del CAM LOCK  
/La dirección correcta de la cerradura de la Cámara

INSERT THE CAM BOLT INTO THE HOLE FIRST, THEN INSERT THE CAM LOCK AND FASTEN IT.  
/FUEHREN SIE ZUERST DEN NOCKENBOLZEN IN DAS BOHRLOCH EIN, ANSCHLIESSEND STECKEN SIE DEN HALTENOCKEN IN DIE DAFUER VORGESEHEN OEFFNUNG UND ZIEHEN IHN AN.  
/INSÉREZ D'ABORD LE BOULON À CAME DANS LE TROU DE PERÇAGE, PUIS INSÉREZ LA CAME DE MAINTIEN DANS L'OUVERTURE PRÉVUE À CELLE-CI ET SERREZ-LA.  
/INSERIRE PRIMA IL BULLONE DELLA CAMMA NEL FORO, POI INSERIRE LA CAMMA DI FISSAGGIO NELL'APERTURA PREVISTA E SERRARE.  
/PRIMERO INSERTE EL PERNO DE LEVA EN EL ORIFICIO DE PERFORACIÓN, LUEGO INSERTE LA LEVA DE SUJECIÓN EN LA ABERTURA PROPORCIONADA PARA ELLO Y APRIETE.

STEP 15  
 SCHRITT 15  
 ÉTAPE 15  
 PASSO 15  
 PASO 15

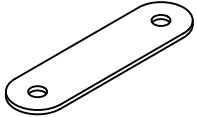
(J)	X6
	
12*45	

(F)	X12
	
ø3*12	

THIS STEP REQUIRES TWO PEOPLE  
 /FUER DIESEN MONTAGESCHRITT WERDEN ZWEI PERSONEN BENOETIGT  
 /DEUX PERSONNES SONT NÉCESSAIRES POUR CETTE ÉTAPE DE MONTAGE  
 /PER QUESTA FASE DI MONTAGGIO SONO NECESSARI DUE PERSONE  
 /SE REQUIEREN DOS PERSONAS PARA ESTE PASO DE MONTAJE

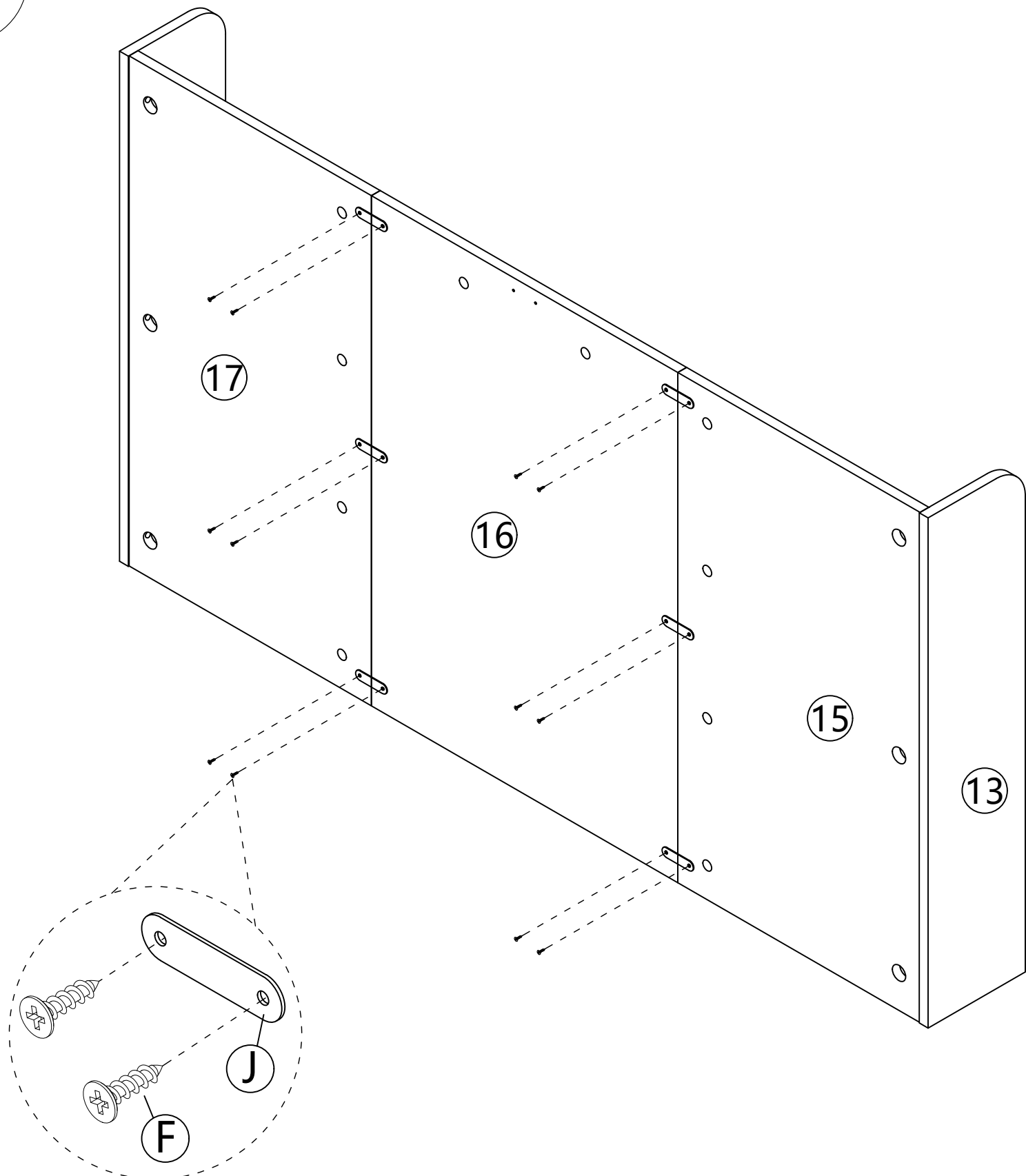
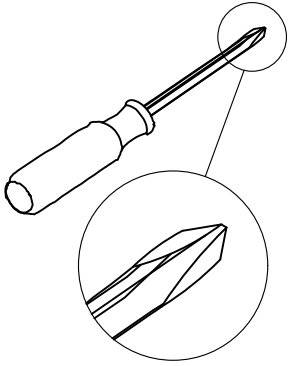

STEP 16  
 SCHRITT 16  
 ÉTAPE 16  
 PASSO 16  
 PASO 16

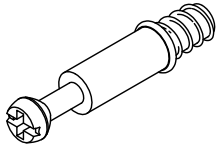
(A)	X8
	
ø6.5*35	

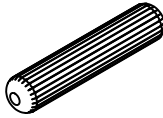
(D)	X6
	
ø6*30	

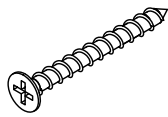
(G)	X11
	
ø4*35	

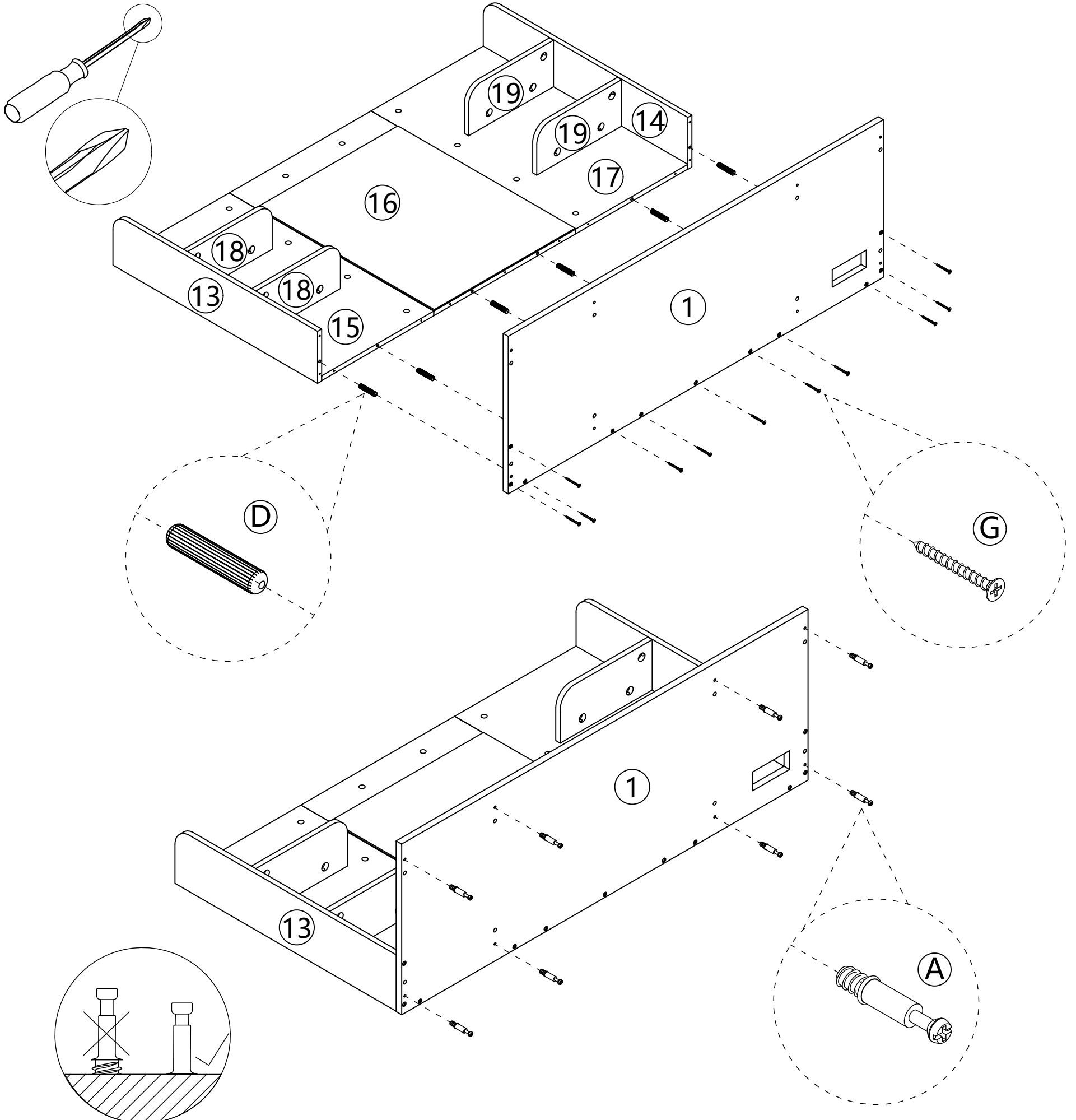

# STEP 17

# SCHRITT 17

# ÉTAPE 17

# PASSO 17

# PASO 17

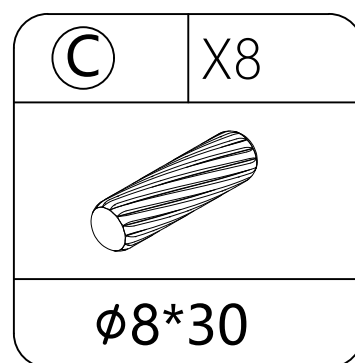
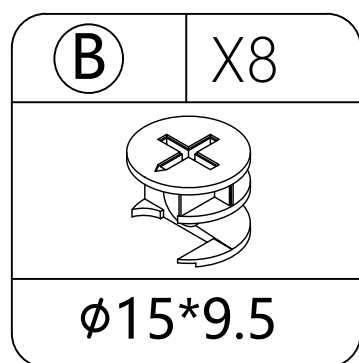

THIS STEP REQUIRES TWO PEOPLE  
 /FUER DIESEN MONTAGESCHRITT WERDEN ZWEI PERSONEN BENOETIGT  
 /DEUX PERSONNES SONT NÉCESSAIRES POUR CETTE ÉTAPE DE MONTAGE  
 /PER QUESTA FASE DI MONTAGGIO SONO NECESSARI DUE PERSONE  
 /SE REQUIEREN DOS PERSONAS PARA ESTE PASO DE MONTAJE

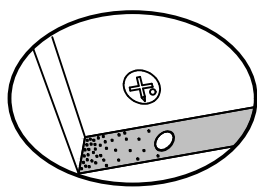
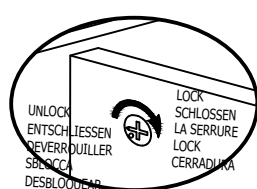
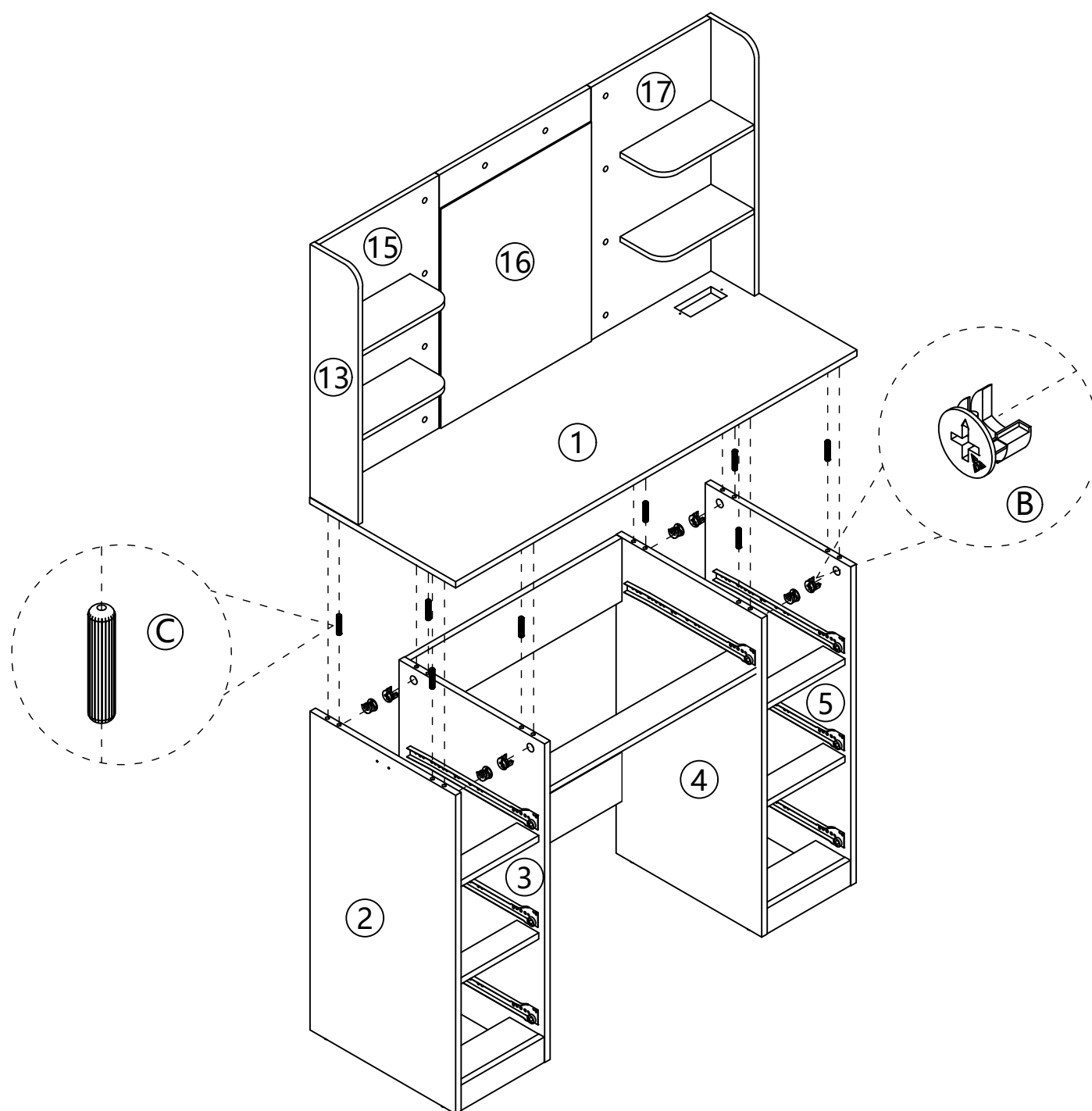
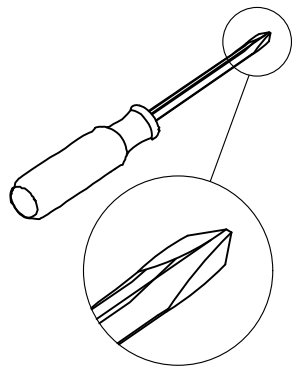

Proper orientation of CAM LOCK  
 /Richtige Ausrichtung des CAM LOCK  
 /La bonne orientation du verrou à came  
 /Orientamento corretto del CAM LOCK  
 /La dirección correcta de la cerradura de la Cámara

INSERT THE CAM BOLT INTO THE HOLE FIRST, THEN INSERT THE CAM LOCK AND FASTEN IT.  
 /FUEHREN SIE ZUERST DEN NOCKENBOLZEN IN DAS BOHRLOCH EIN, ANSCHLIESSEND STECKEN SIE DEN HALTENOCKEN IN DIE DAFUER VORGESEHEN OEFFNUNG UND ZIEHEN IHN AN.  
 /INSÉREZ D'ABORD LE BOULON À CAME DANS LE TROU DE PERÇAGE, PUIS INSÉREZ LA CAME DE MAINTIEN DANS L'OUVERTURE PRÉVUE À CELLE-CI ET SERREZ-LA.  
 /INSERIRE PRIMA IL BULLONE DELLA CAMMA NEL FORO, POI INSERIRE LA CAMMA DI FISSAGGIO NELL'APERTURA PREVISTA E SERRARE.  
 /PRIMERO INSERTE EL PERNO DE LEVA EN EL ORIFICIO DE PERFORACIÓN, LUEGO INSERTE LA LEVA DE SUJECIÓN EN LA ABERTURA PROPORCIONADA PARA ELLO Y APRIETE.

# STEP 18

## SCHRITT 18

### ÉTAPE 18

### PASSO 18

### PASO 18

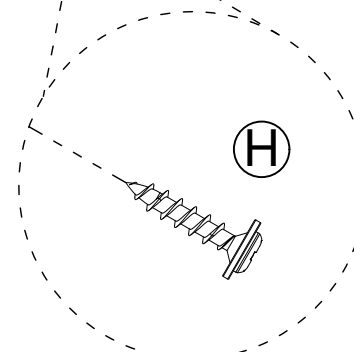
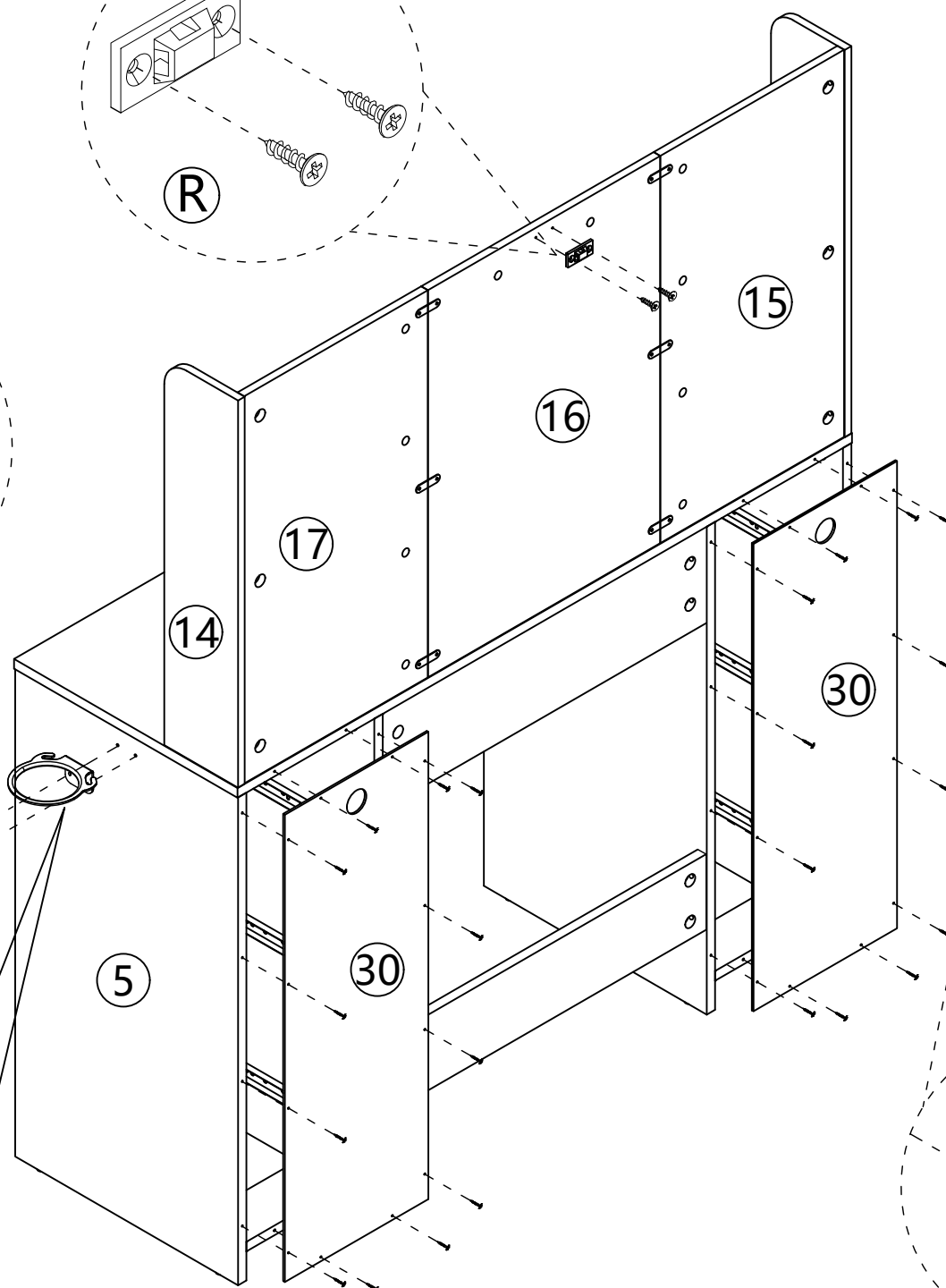
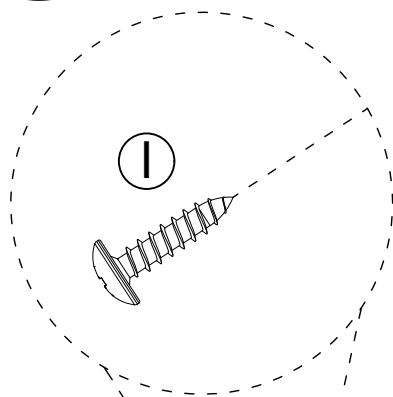
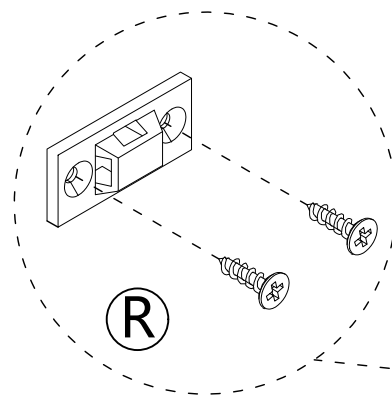
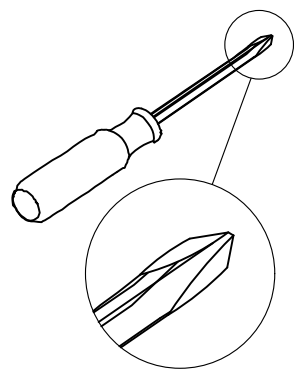
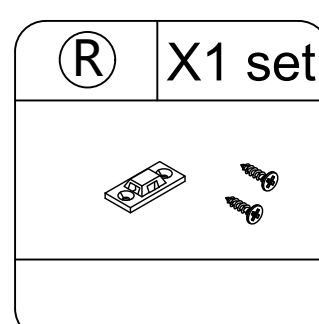
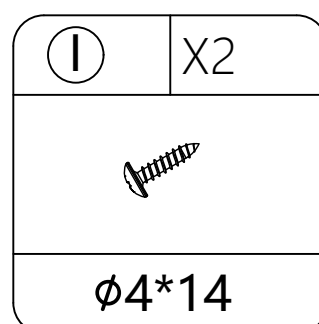
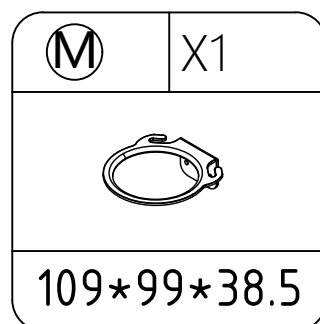
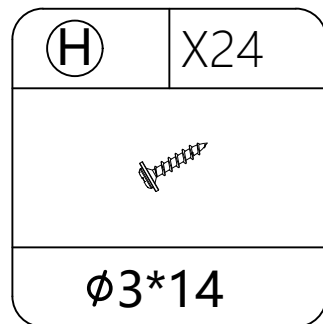

YOU CAN INSTALL THE HAIRDRYER MOUNT (M) ON THE LEFT OR THE RIGHT HAND SIDE ACCORDING TO YOUR NEEDS  
 /SIE KOENNEN DIE FOEHNHALTERUNG (M) WUNSCHGEMAESS AUF DER LINKEN ODER RECHTEN SEITE ANBRINGEN.  
 /VOUS POUVEZ FIXER LE SUPPORT À CHEVEUX (M) SUR LE CÔTÉ GAUCHE OU DROIT SELON NÉCESSAIRE.  
 /È POSSIBILE FISSARE IL SUPPORTO PER CAPELLI (M) SUL LATO SINISTRO O DESTRO COME NECESSARIO.  
 /PUEDES FIJAR EL SOPORTE PARA EL PELO (M) EN EL LADO IZQUIERDO O DERECHO SEGÚN SE NECESITE.

# STEP 19

# SCHRITT 19

# ÉTAPE 19

# PASSO 19

# PASO 19

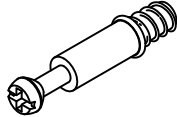
(A)	X20
	
Ø6.5*35	

(B)	X20
	
Ø15*9.5	

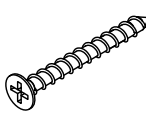
(G)	X20
	
Ø4*35	

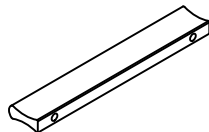
(K)	X5
	
106*16*8	

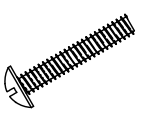
(L)	X10
	
Ø4*18	

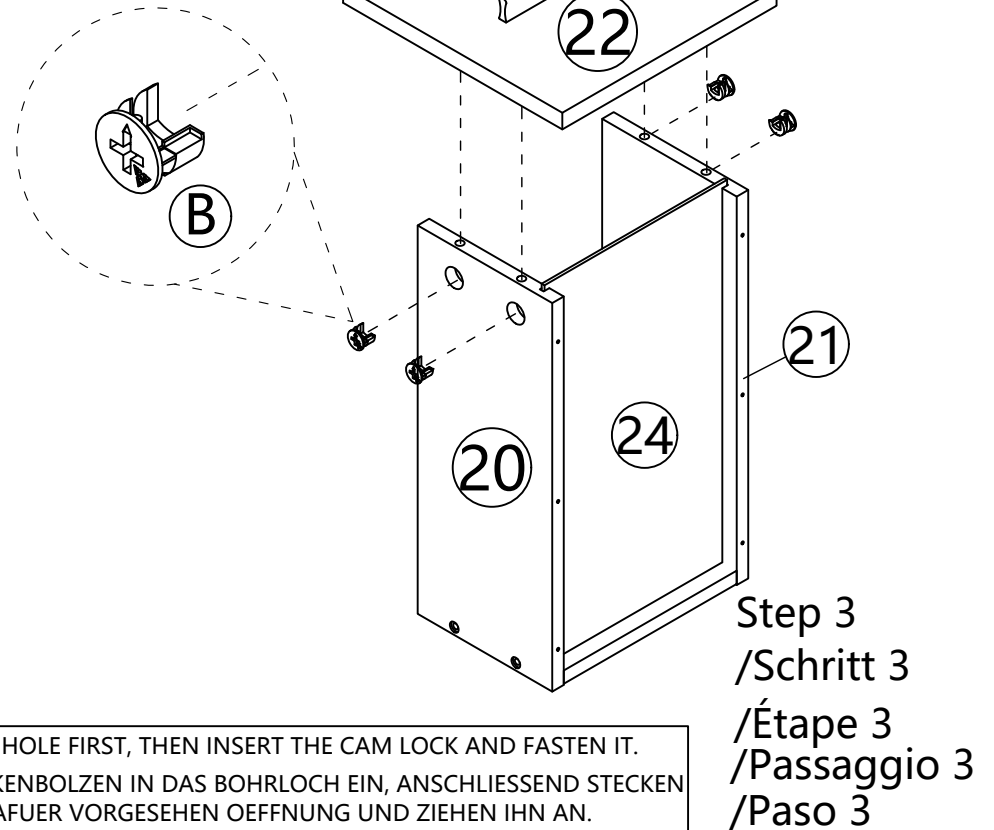
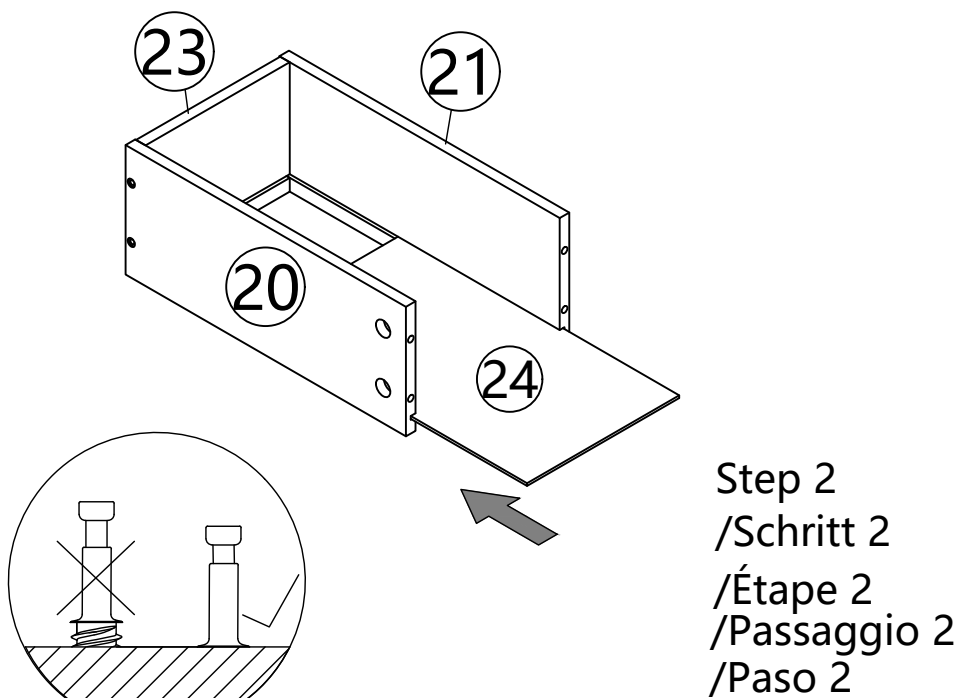
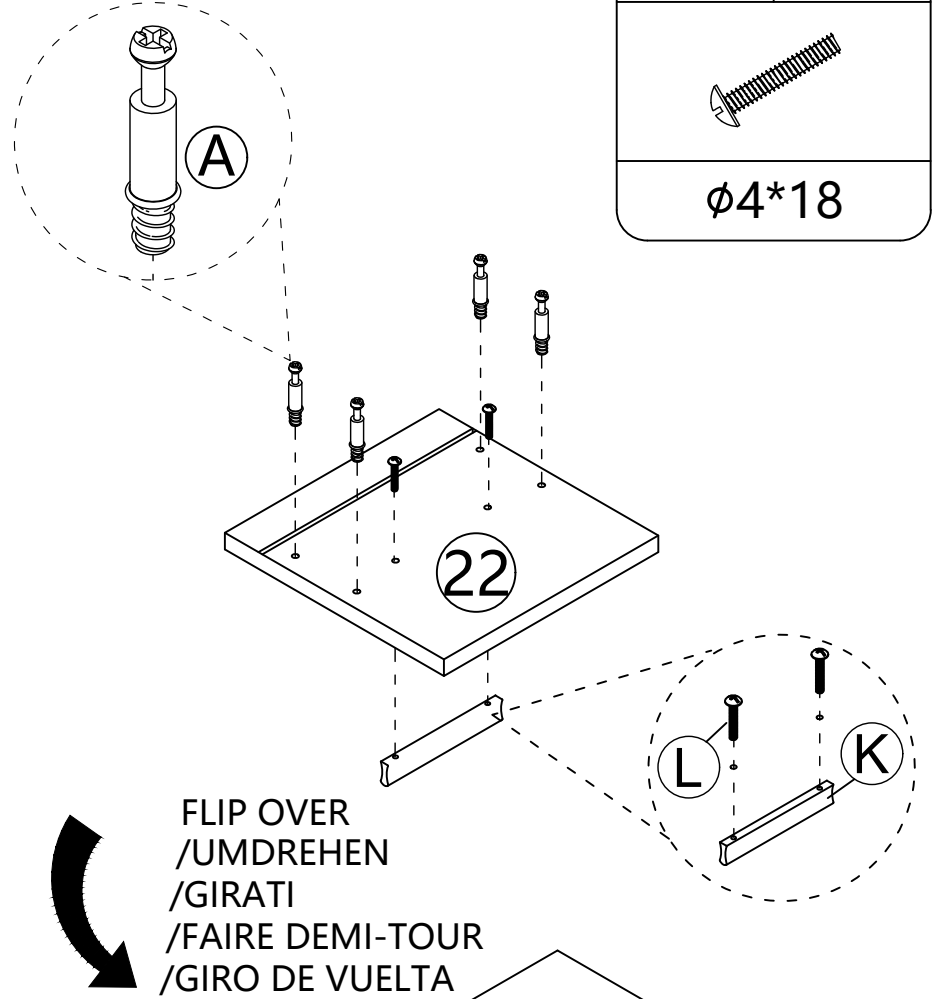
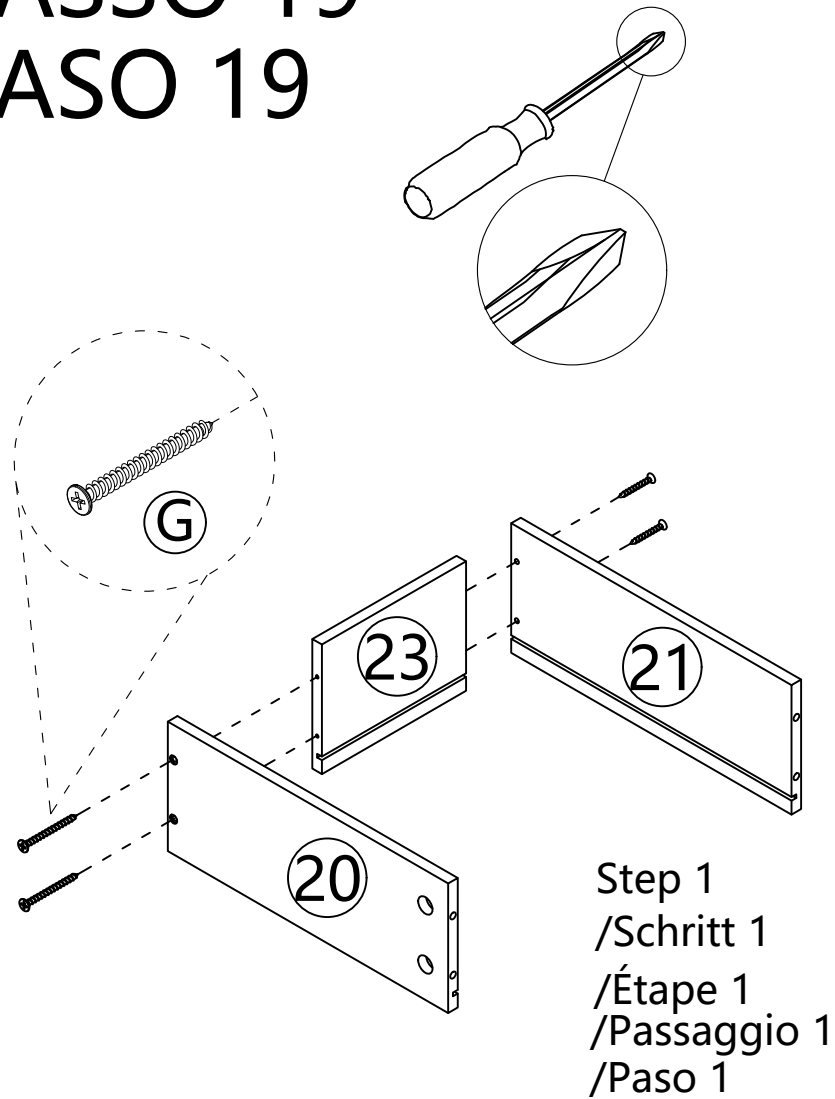

INSERT THE CAM BOLT INTO THE HOLE FIRST, THEN INSERT THE CAM LOCK AND FASTEN IT.  
/FUEHREN SIE ZUERST DEN NOCKENBOLZEN IN DAS BOHRLOCH EIN, ANSCHLIESSEND STECKEN SIE DEN HALTENOCKEN IN DIE DAFUER VORGESEHEN OEFFNUNG UND ZIEHEN IHN AN.  
/INSÉREZ D'ABORD LE BOULON À CAME DANS LE TROU DE PERÇAGE, PUIS INSÉREZ LA CAME DE MAINTIEN DANS L'OUVERTURE PRÉVUE À CELLE-CI ET SERREZ-LA.  
/INSERIRE PRIMA IL BULLONE DELLA CAMMA NEL FORO, POI INSERIRE LA CAMMA DI FISSAGGIO NELL'APERTURA PREVISTA E SERRARE.  
/PRIMERO INSERTE EL PERNO DE LEVA EN EL ORIFICIO DE PERFORACIÓN, LUEGO INSERTE LA LEVA DE SUJECCIÓN EN LA ABERTURA PROPORCIONADA PARA ELLO Y APRIETE.

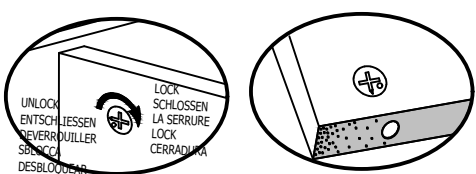

Proper orientation of CAM LOCK  
/Richtige Ausrichtung des CAM LOCK  
/La bonne orientation du verrou à came  
/Orientamento corretto del CAM LOCK  
/La dirección correcta de la cerradura de la Cámara

# X5

# STEP 20

## SCHRITT 20

### ÉTAPE 20

### PASSO 20

### PASO 20

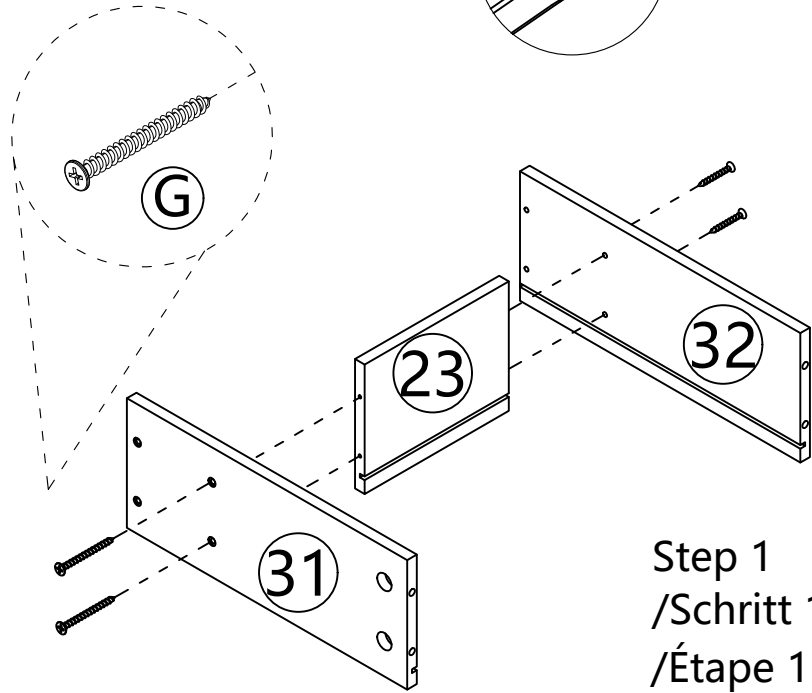
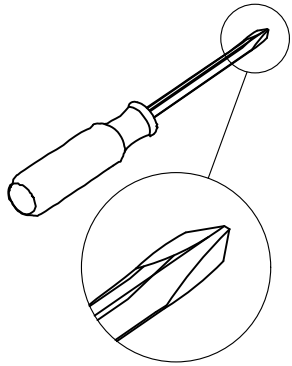
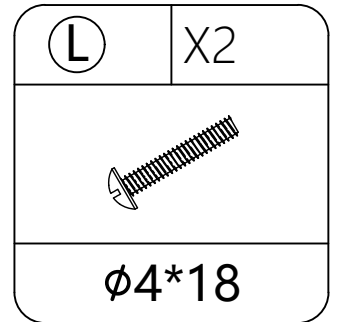
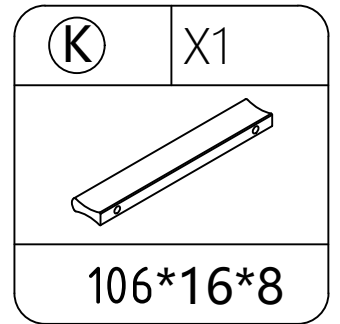
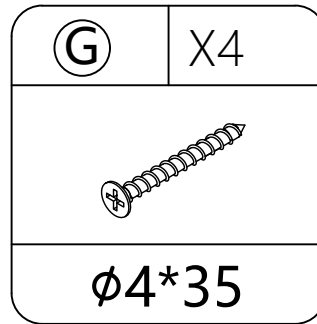
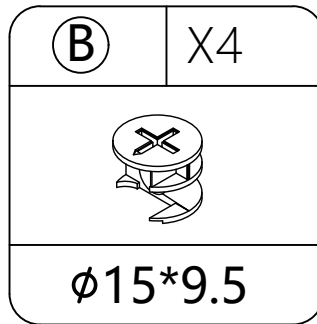
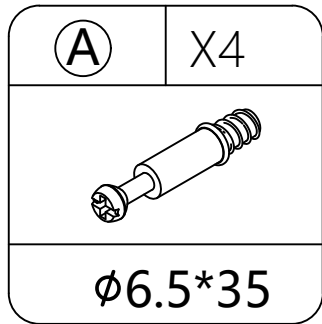

Step 1  
/Schritt 1  
/Étape 1  
/Passaggio 1  
/Paso 1

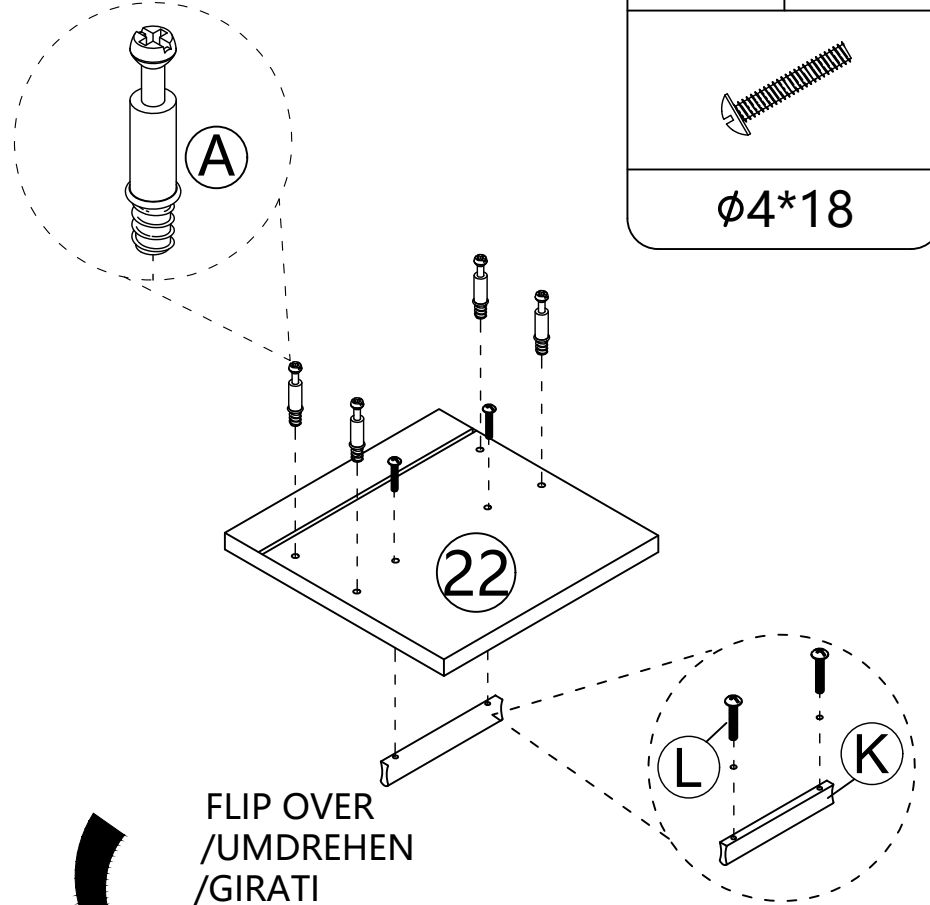

FLIP OVER  
/UMDREHEN  
/GIRATI  
/FAIRE DEMI-TOUR  
/GIRO DE VUELTA

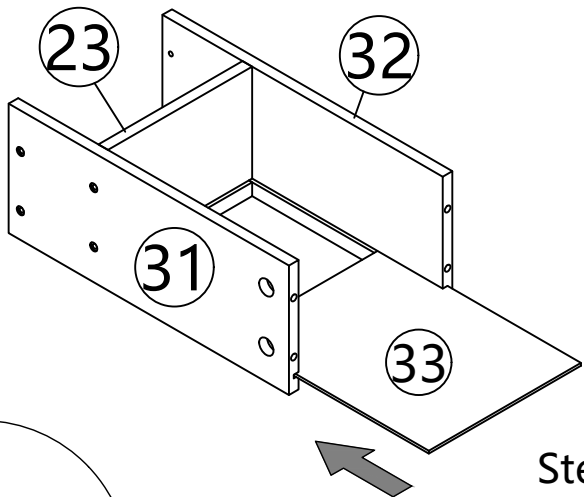

Step 2  
/Schritt 2  
/Étape 2  
/Passaggio 2  
/Paso 2

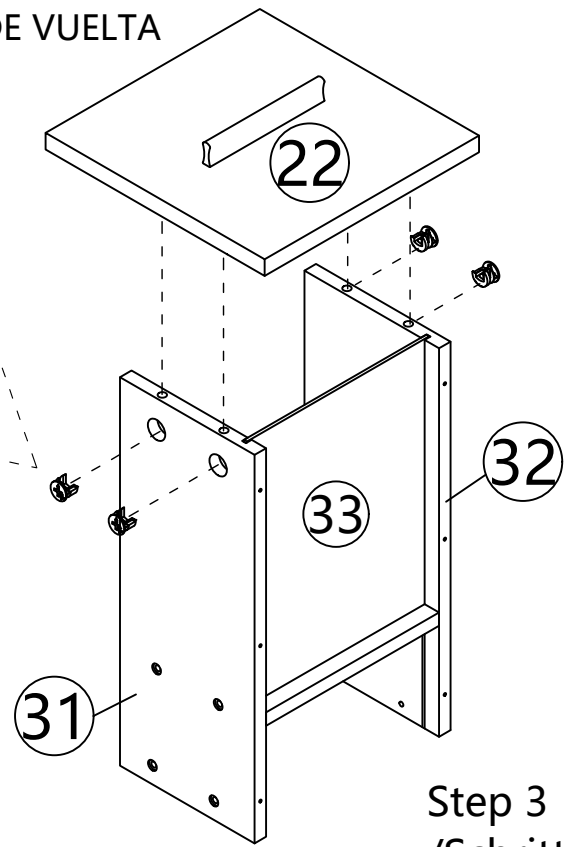

Step 3  
/Schritt 3  
/Étape 3  
/Passaggio 3  
/Paso 3

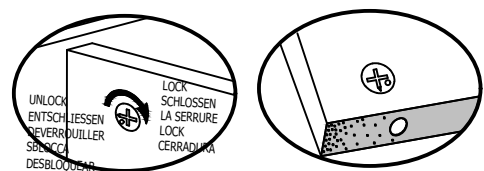
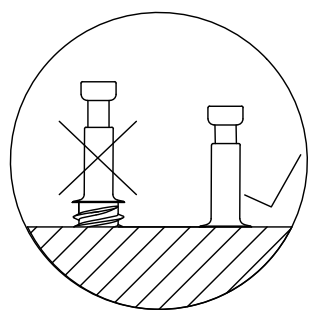

Proper orientation of CAM LOCK  
/Richtige Ausrichtung des CAM LOCK  
/La bonne orientation du verrou à came  
/Orientamento corretto del CAM LOCK  
/La dirección correcta de la cerradura de la Cámara

INSERT THE CAM BOLT INTO THE HOLE FIRST, THEN INSERT THE CAM LOCK AND FASTEN IT.  
/FUEHREN SIE ZUERST DEN NOCKENBOLZEN IN DAS BOHRLOCH EIN, ANSCHLIESSEND STECKEN SIE DEN HALTENOCKEN IN DIE DAFUER VORGESEHEN OEFFNUNG UND ZIEHEN IHN AN.  
/INSÉREZ D'ABORD LE BOULON À CAME DANS LE TROU DE PERÇAGE, PUIS INSÉREZ LA CAME DE MAINTIEN DANS L'OUVERTURE PRÉVUE À CELLE-CI ET SERREZ-LA.  
/INSERIRE PRIMA IL BULLONE DELLA CAMMA NEL FORO, POI INSERIRE LA CAMMA DI FISSAGGIO NELL'APERTURA PREVISTA E SERRARE.  
/PRIMERO INSERTE EL PERNO DE LEVA EN EL ORIFICIO DE PERFORACIÓN, LUEGO INSERTE LA LEVA DE SUJECCIÓN EN LA ABERTURA PROPORCIONADA PARA ELLO Y APRIETE.

# STEP 21

# SCHRITT 21

# ÉTAPE 21

# PASSO 21

# PASO 21

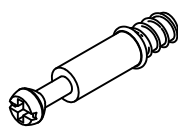
<b>A</b>	X4
	
Ø6.5*35	

<b>B</b>	X4
	
Ø15*9.5	

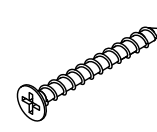
<b>G</b>	X4
	
Ø4*35	

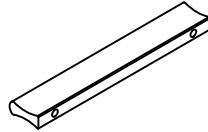
<b>K</b>	X1
	
106*16*8	

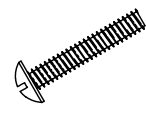
<b>L</b>	X2
	
Ø4*18	

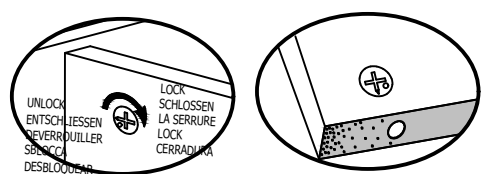
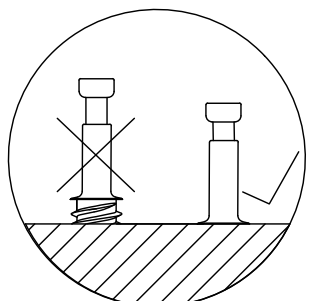
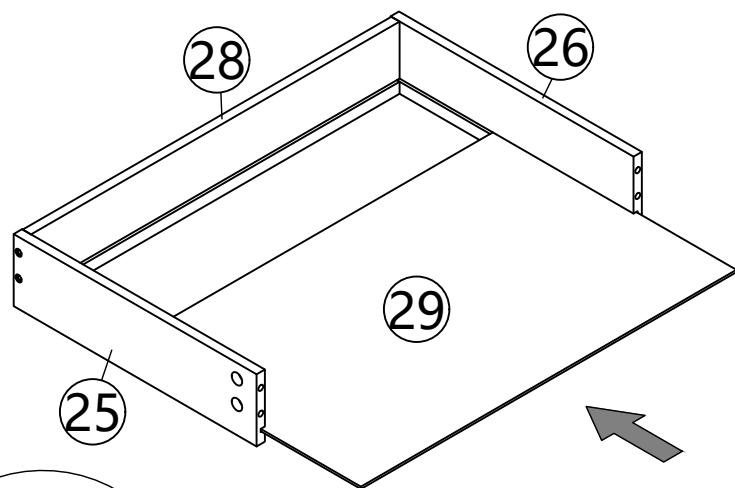
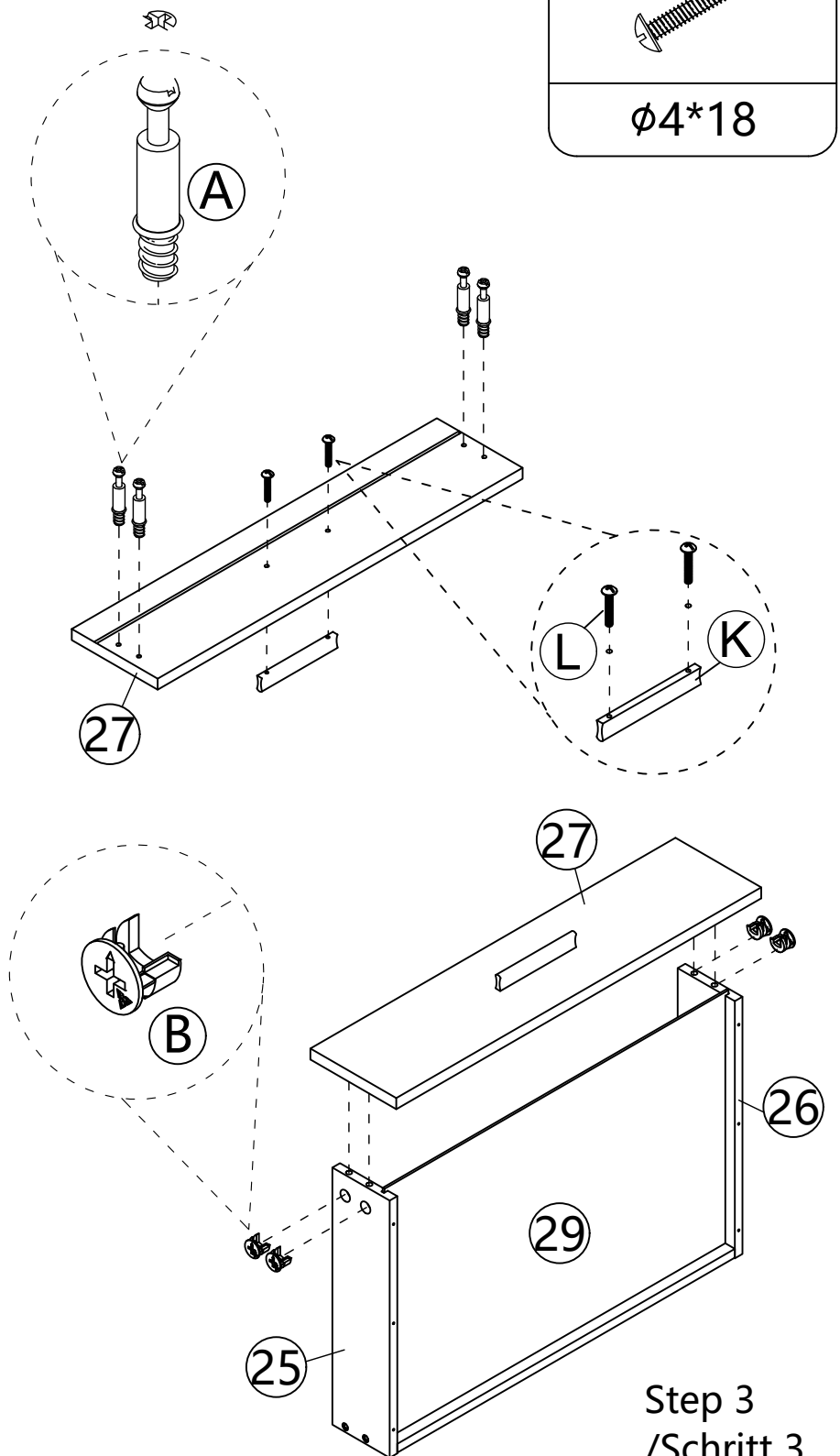
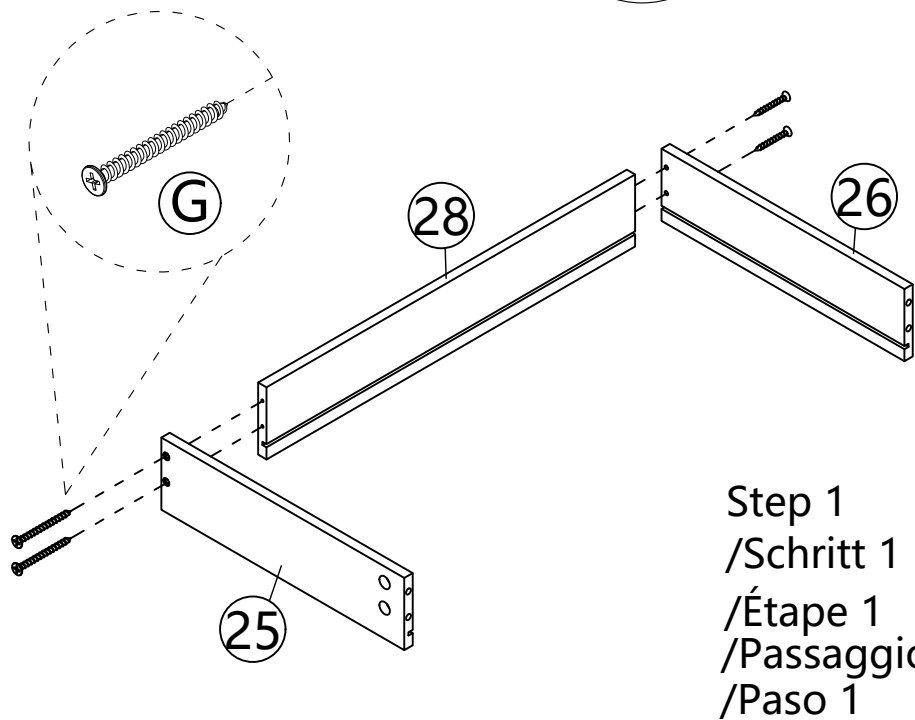
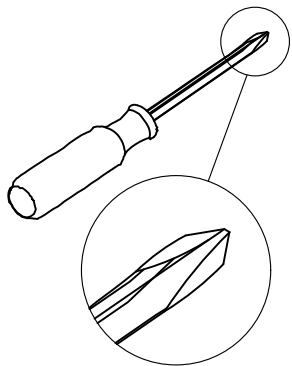

Proper orientation of CAM LOCK  
/Richtige Ausrichtung des CAM LOCK  
/La bonne orientation du verrou à came  
/Orientamento corretto del CAM LOCK  
/La dirección correcta de la cerradura de la Cámara

INSERT THE CAM BOLT INTO THE HOLE FIRST, THEN INSERT THE CAM LOCK AND FASTEN IT.  
/FUEHREN SIE ZUERST DEN NOCKENBOLZEN IN DAS BOHRLOCH EIN, ANSCHLIESSEND STECKEN SIE DEN HALTENOCKEN IN DIE DAFUER VORGESEHEN OEFFNUNG UND ZIEHEN IHN AN.  
/INSÉREZ D'ABORD LE BOULON À CAME DANS LE TROU DE PERÇAGE, PUIS INSÉREZ LA CAME DE MAINTIEN DANS L'OUVERTURE PRÉVUE À CELLE-CI ET SERREZ-LA.  
/INSERIRE PRIMA IL BULLONE DELLA CAMMA NEL FORO, POI INSERIRE LA CAMMA DI FISSAGGIO NELL'APERTURA PREVISTA E SERRARE.  
/PRIMERO INSERTE EL PERNO DE LEVA EN EL ORIFICIO DE PERFORACIÓN, LUEGO INSERTE LA LEVA DE SUJECCIÓN EN LA ABERTURA PROPORCIONADA PARA ELLO Y APRIETE.

STEP 22  
 SCHRITT 22  
 ÉTAPE 22  
 PASSO 22  
 PASO 22

(E)	X30
	
Ø3.5*14	

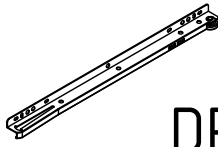
(N)	X5
	
DR L=350	

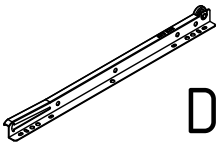
(N)	X5
	
DL L=350	

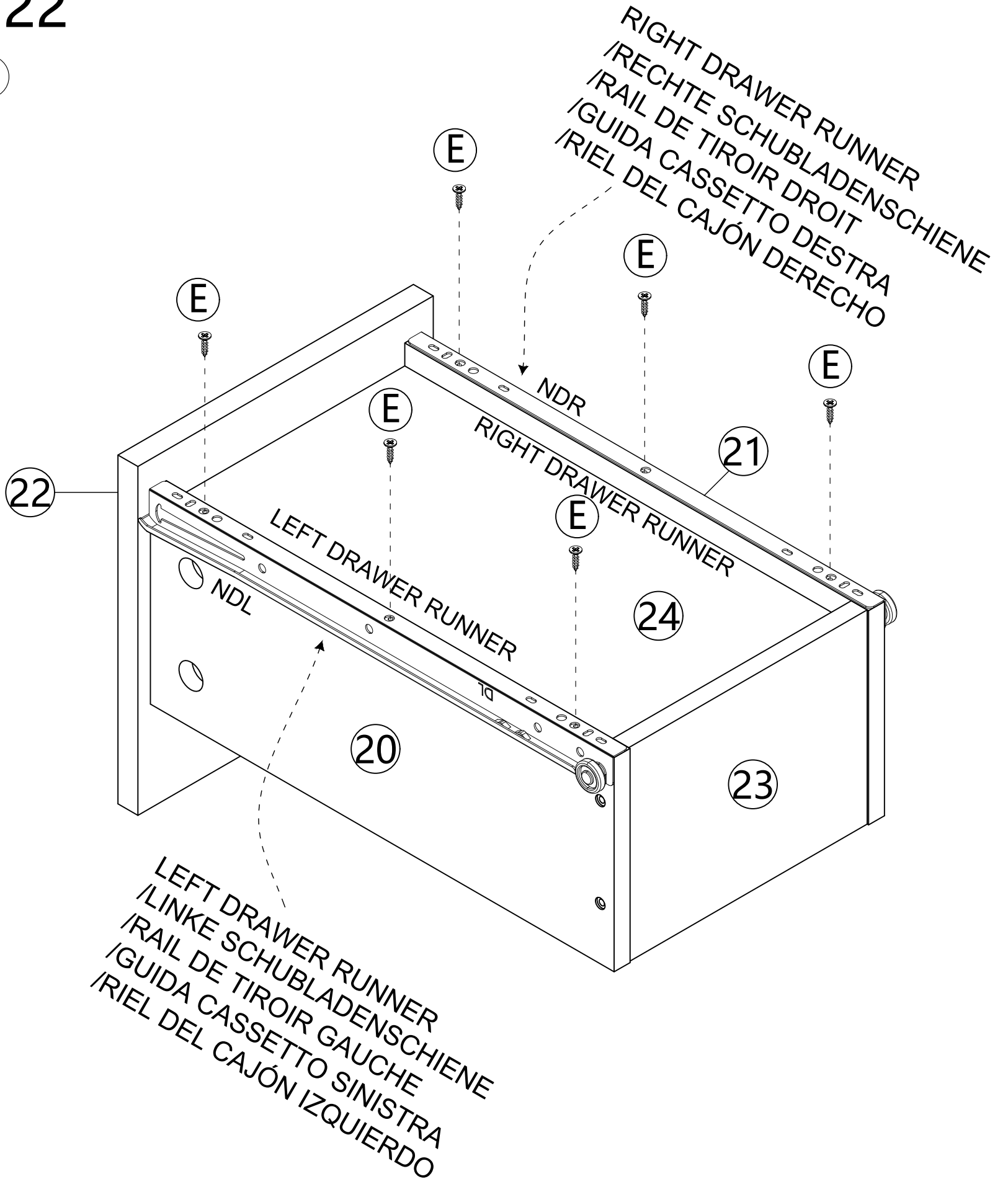
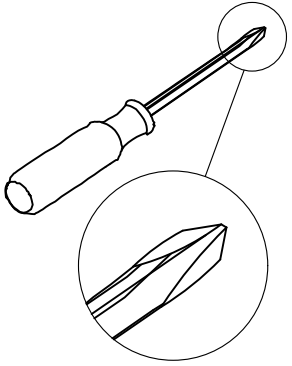

X5

STEP 23  
 SCHRITT 23  
 ÉTAPE 23  
 PASSO 23  
 PASO 23

(E)	X6
	
Ø3.5*14	

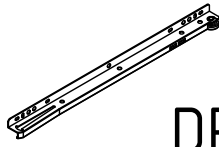
(N)	X1
	
L=350	

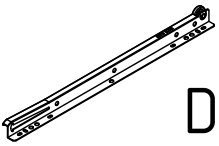
(N)	X1
	
L=350	

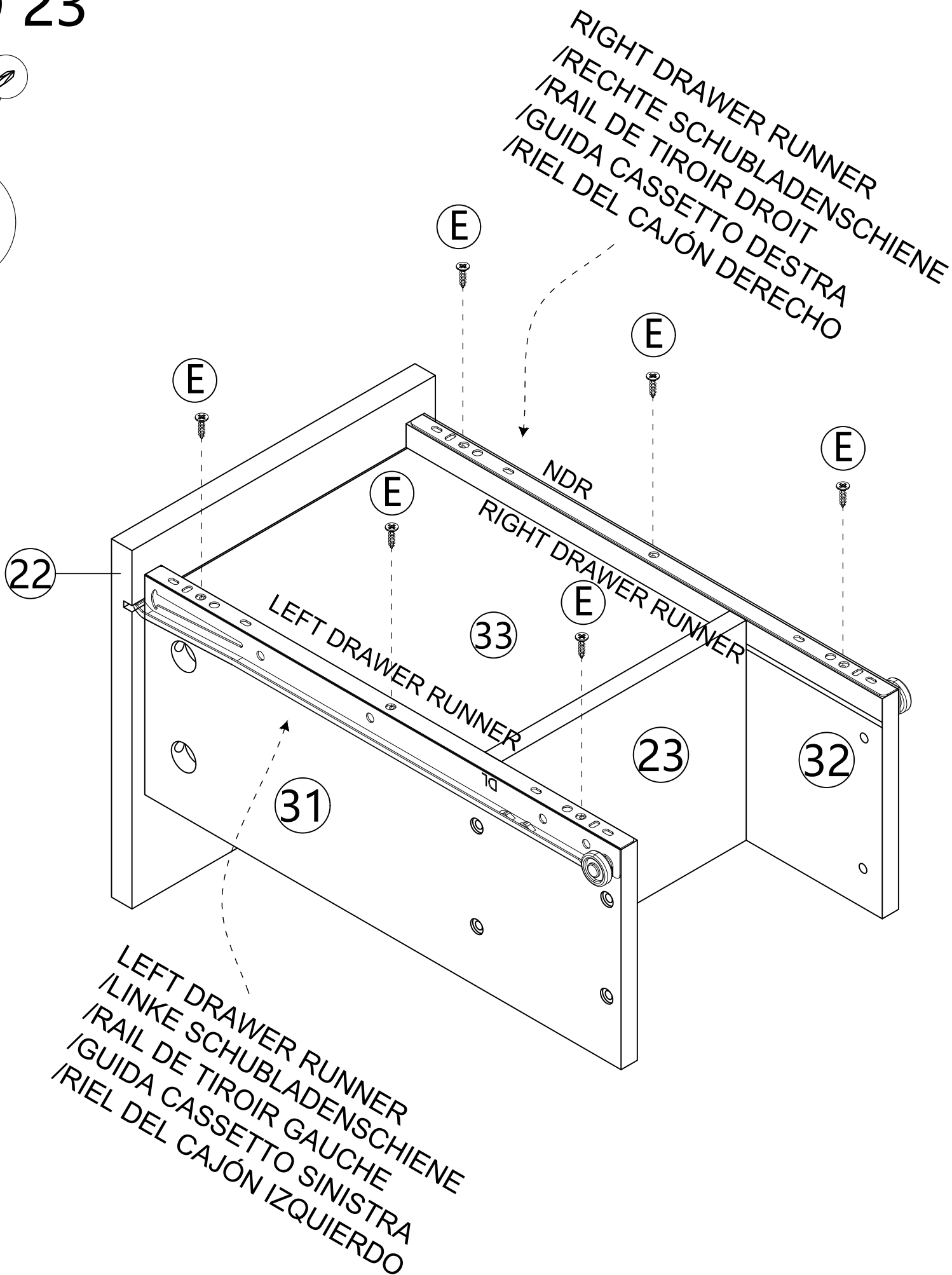
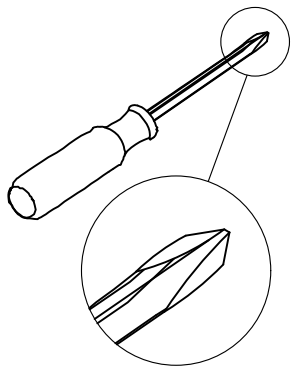

STEP 24  
 SCHRITT 24  
 ÉTAPE 24  
 PASSO 24  
 PASO 24

(E)	X6
	
Ø3.5*14	

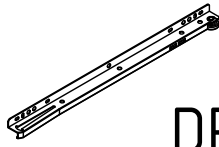
(N)	X1
	
DR	
L=350	

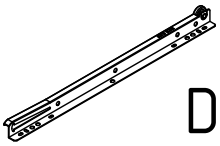
(N)	X1
	
DL	
L=350	

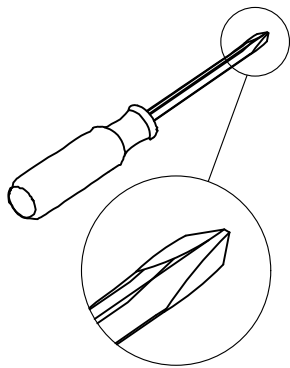

RIGHT DRAWER RUNNER  
 /RECHTE SCHUBLADENSCHIENE  
 /RAIL DE TIROIR DROIT  
 /GUIDA CASSETTO DESTRA  
 /RIEL DEL CAJÓN DERECHO

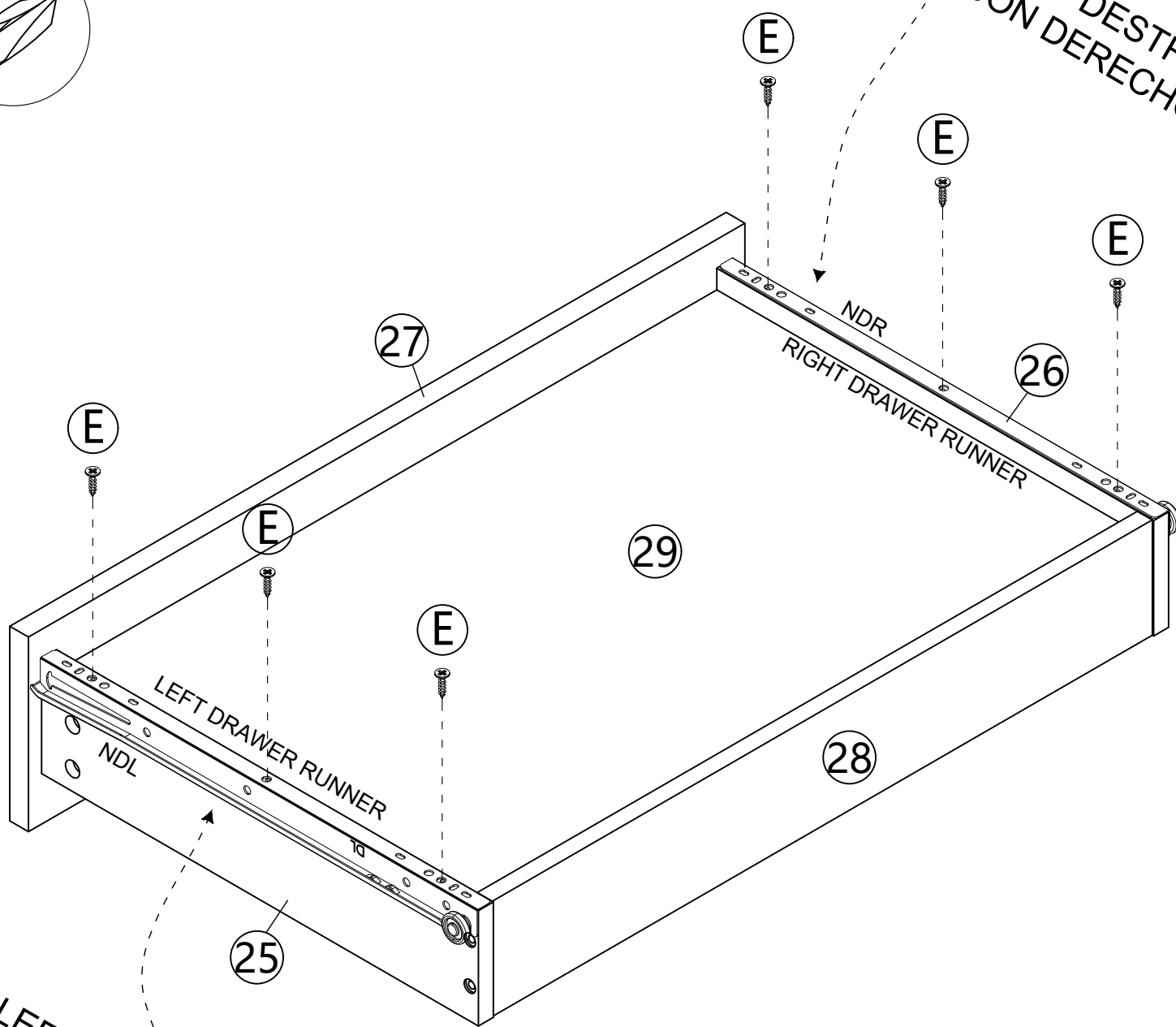

LEFT DRAWER RUNNER  
 /LINKE SCHUBLADENSCHIENE  
 /RAIL DE TIROIR GAUCHE  
 /GUIDA CASSETTO SINISTRA  
 /RIEL DEL CAJÓN IZQUIERDO

STEP 25  
 SCHRITT 25  
 ÉTAPE 25  
 PASSO 25  
 PASO 25

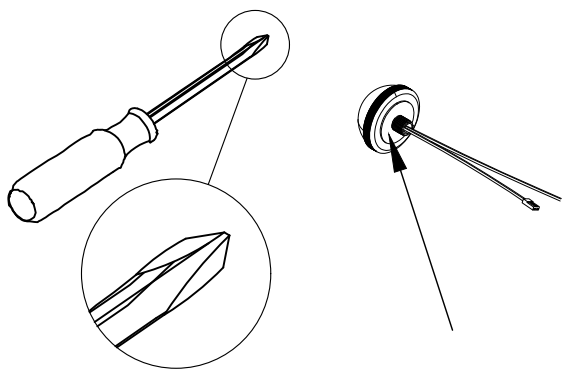
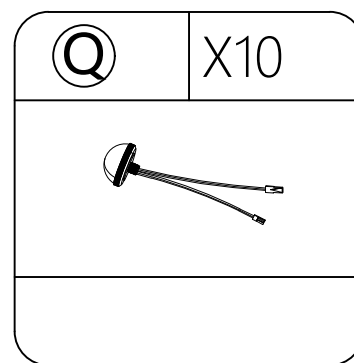
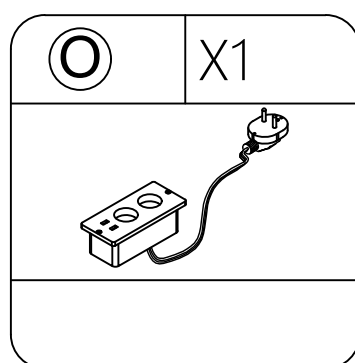
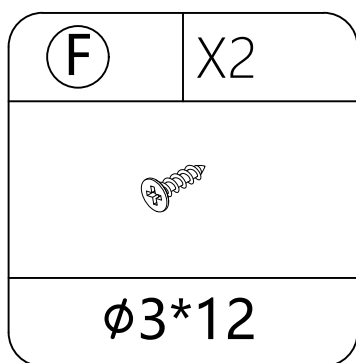

REMOVE THE LID FROM THE GLUESTRIP .

/ENTFERNEN SIE DAS PAPIER VON DER KLEBEFLAECHE.

/RETIREZ LE PAPIER DE LA SURFACE ADHÉSIVE.

/RIMUOVERE LA CARTA DALLA SUPERFICIE ADESIVA.

/QUITAR EL PAPEL DE LA SUPERFICIE ADHESIVA.

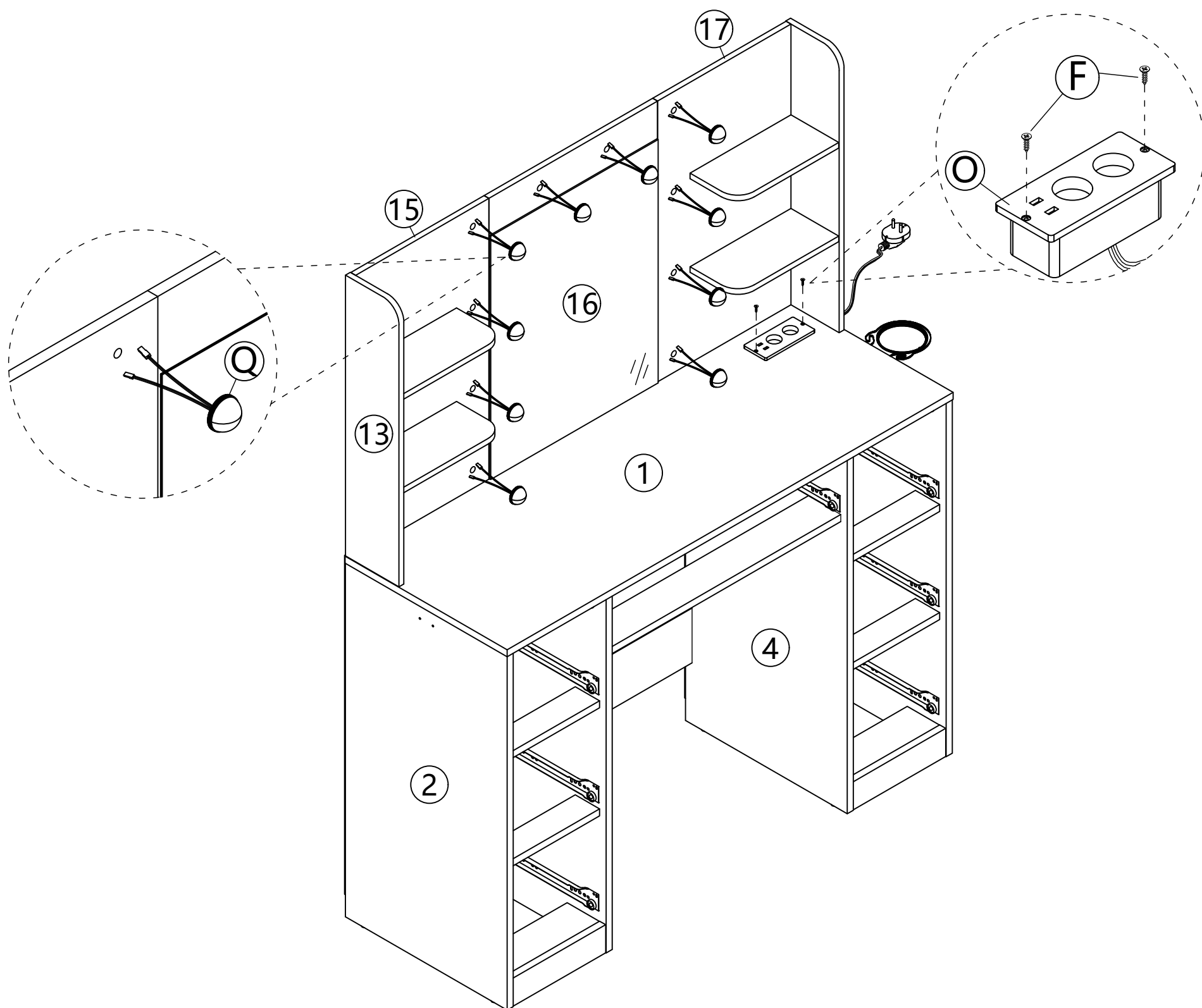

# STEP 26

## SCHRITT 26

### ÉTAPE 26

### PASSO 26

### PASO 26

Pass the bulb wires through the pre-punched holes in the plate and then gently press the glued side of the bulbs to the plate, until they firmly stick. Now connect the adjacent bulbs using the plugs and sockets. Make sure the connection is established by linking cables of the same colour with each other. Doing your makeup, use the switch to operate the light. You can choose between three different light colours ranging from cold to warm as well as different intensity. This allows you to prepare your makeup in the right light conditions for maximum comfort & optimal result, daytime light for work or school makeup, less intense, warm light for party and going out makeup. Press the ON button briefly to change the light color, hold the ON button to adjust brightness.

Stecken Sie die Lampenkabel durch die vorgestanzten Löcher in der Platte und drücken Sie anschließend die Glühbirnen mit der Klebeseite vorsichtig an, bis sie fest kleben. Verbinden Sie jetzt die nebeneinanderliegenden Glühlampen durch die Steckverbindungen der Kabel. Stellen Sie sicher, dass die Kabel mit der jeweils gleichfarbigem Gegenseite verbunden sind. Wenn Sie den Schminktisch benutzen, verwenden Sie den Schalter, um die Beleuchtung zu bedienen. Sie können zwischen drei verschiedenen Farbtemperaturen von kalt bis warm wählen sowie deren Intensität einstellen. Diese Funktion erlaubt es Ihnen, Ihr Make-up unter den zu erwartenden Lichtverhältnissen aufzutragen, um das optimale Ergebnis zu erzielen - kaltes Tageslicht für das Make-up für Schule, Uni oder Büro - weniger intensives, warmes Licht für Party und abendliches Ausgehen. Drücken Sie kurz auf die "ON" Taste, um zwischen den Farbtemperaturen zu wechseln, halten Sie die "ON" Taste gedrückt, um die Helligkeit einzustellen.

Insérez les câbles de la lampe dans les trous pré-perçés de la plaque et appuyez ensuite délicatement sur les ampoules avec le côté adhésif jusqu'à ce qu'elles soient fermes. Connectez maintenant les ampoules adjacentes via les connecteurs de câbles. Assurez-vous que les câbles sont connectés à chaque côté opposé de la même couleur. Lorsque vous utilisez la coiffeuse, utilisez l'interrupteur pour faire fonctionner l'éclairage. Vous pouvez choisir entre trois températures de couleur du froid au chaud ainsi que leur intensité ensemble. Cette fonctionnalité vous permet de personnaliser votre maquillage parmi ceux attendus. Conditions d'éclairage pour obtenir un résultat optimal - lumière du jour froide pour le maquillage à l'école, à l'université ou au bureau - lumière chaude moins intense pour fête et soirée. Appuyez brièvement sur le bouton « ON » pour basculer. Pour modifier les températures de couleur, appuyez et maintenez le bouton « ON » pour modifier la température de couleur. Ajustez la luminosité."

Inserire i cavi della lampada attraverso i fori preforati nella piastra e quindi premere con attenzione le lampadine con il lato adesivo finché non sono ben salde. Ora collega le lampadine adiacenti attraverso i connettori per cavi. Assicurarsi che i cavi siano collegati a ciascuno lato opposto dello stesso colore. Quando usi la toletta, utilizzare l'interruttore per azionare l'illuminazione. Puoi scegliere tra tre diverse temperature di colore da freddo a caldo e la loro intensità impostata. Questa funzionalità ti permette di personalizzare il tuo trucco tra quelli previsti. Condizioni di luce per ottenere il risultato ottimale: luce del giorno fredda per il trucco per la scuola, l'università o l'ufficio - luce meno intensa e calda per festa e serata fuori. Premere brevemente il pulsante "ON" per passare da uno all'altro. Per modificare la temperatura del colore, tenere premuto il pulsante "ON" per modificare la temperatura del colore. Regola la luminosità."

Inserte los cables de la lámpara a través de los orificios perforados en la placa y luego presione con cuidado las bombillas con el lado adhesivo hasta que queden firmes. Ahora conecte las bombillas adyacentes a través de los conectores de cables. Asegúrese de que los cables estén conectados entre sí. lado opuesto del mismo color. Cuando uses el tocador, utilice el interruptor para operar la iluminación. Puedes elegir entre tres temperaturas de color de frío a cálido así como su intensidad. colocar. Esta característica te permite personalizar tu maquillaje entre los esperados. Condiciones de luz para lograr el resultado óptimo: luz fría del día para maquillaje en la escuela, la universidad o la oficina: luz cálida y menos intensa para fiesta y velada. Presione brevemente el botón "ON" para cambiar entre Para cambiar las temperaturas de color, mantenga presionado el botón "ON" para cambiar la temperatura de color. Ajusta el brillo."

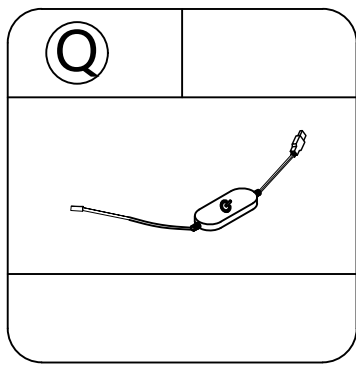

Matching colours.  
 /Identische Farben verbinden  
 /Connectez des couleurs identiques  
 /Collega colori identici  
 /Conecta colores idénticos

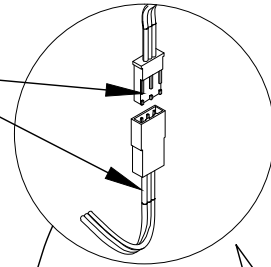
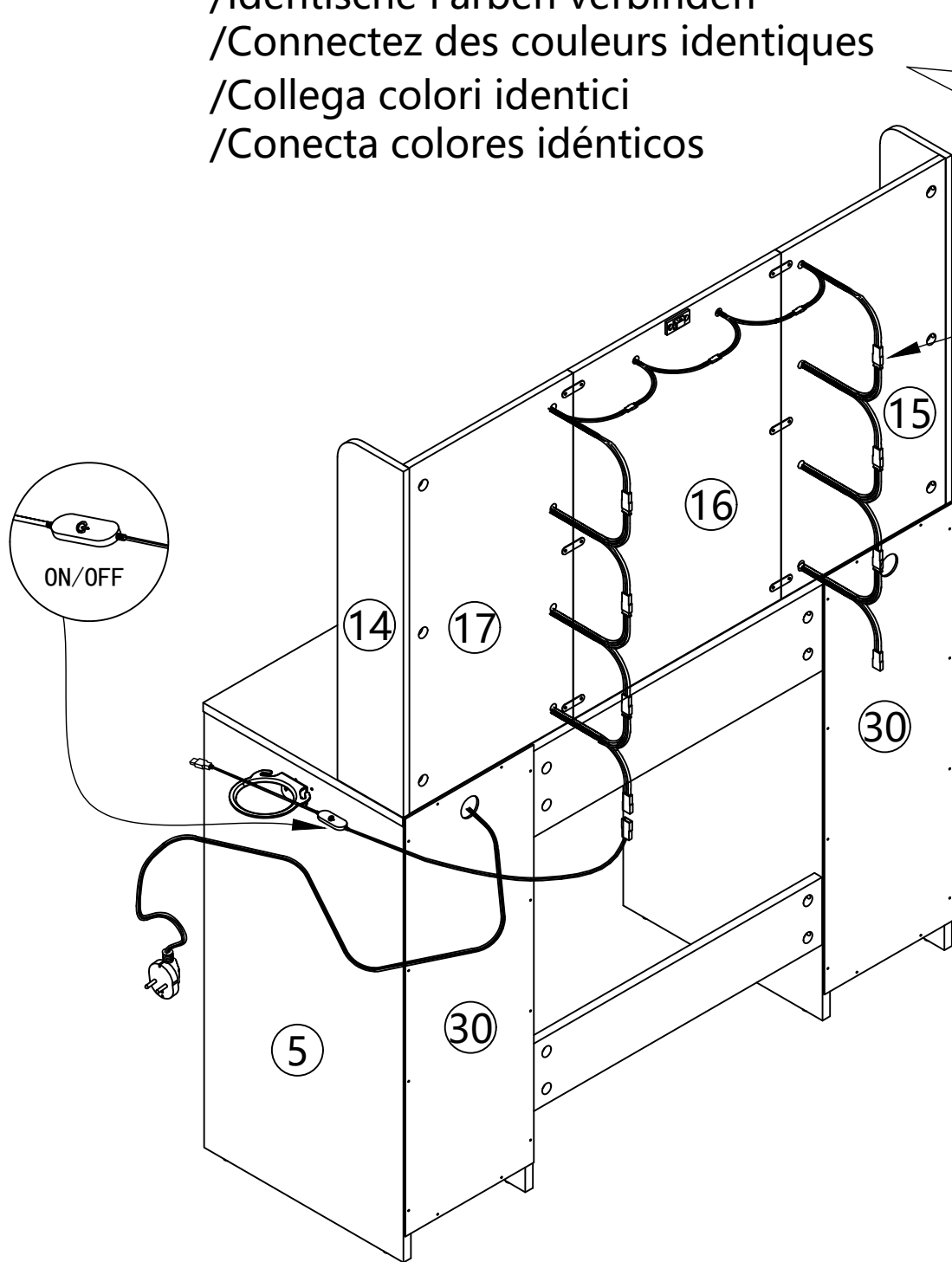

When connecting the plugs and sockets please make sure the connection is established between matching cable colors.

Achten Sie beim verbinden der Kabel darauf, dass sie die Stecker und Dose farbgleich verbinden.

Lors du branchement des câbles, assurez-vous que les fiches et les prises sont de la même couleur.

Quando si collegano i cavi, assicurarsi che le spine e le prese siano dello stesso colore.

Al conectar los cables, asegúrese de que los enchufes y las tomas sean del mismo color.

STEP 27  
 SCHRITT 27  
 ÉTAPE 27  
 PASSO 27  
 PASO 27

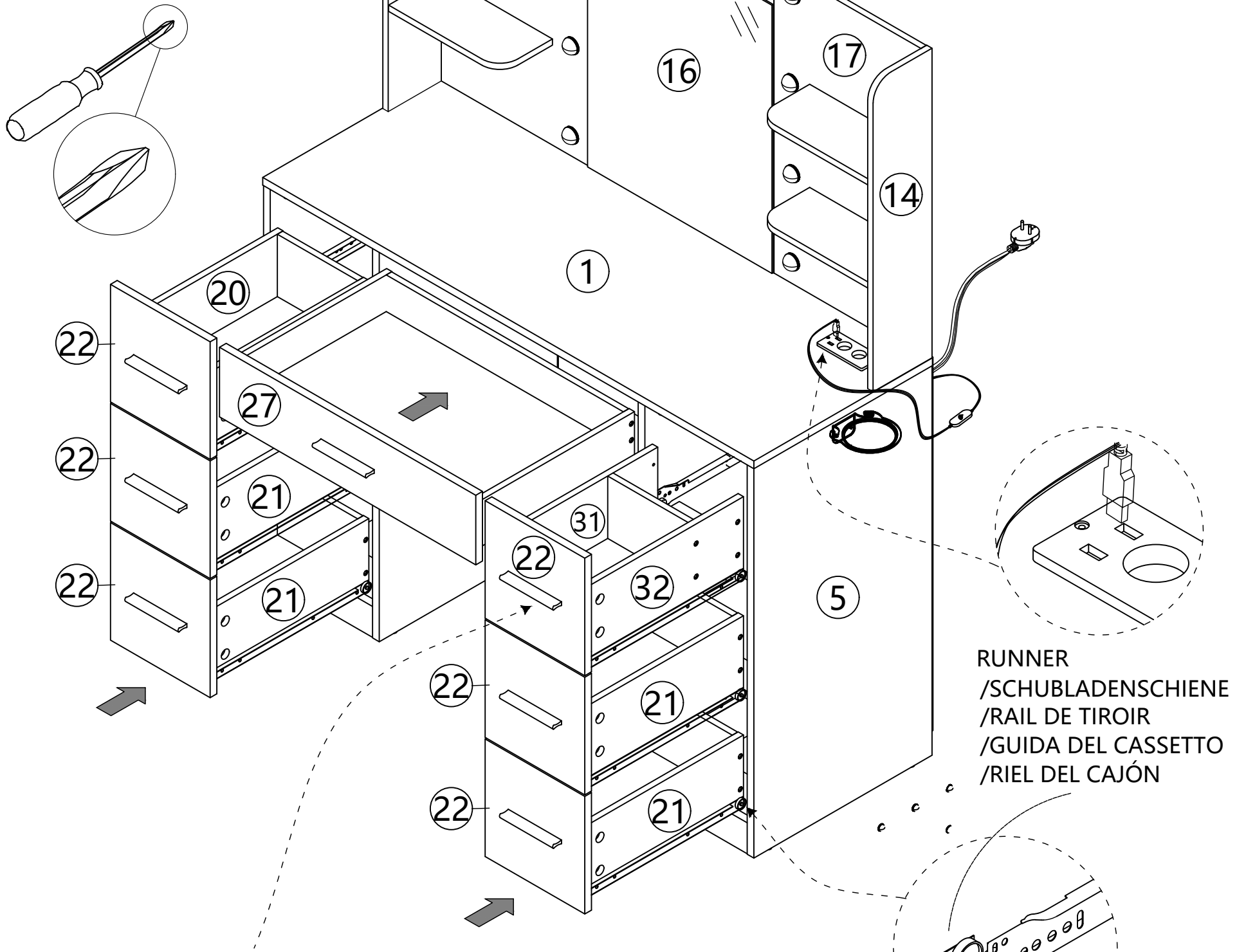

RUNNER  
 /SCHUBLADENSCHIENE  
 /RAIL DE TIROIR  
 /GUIDA DEL CASSETTO  
 /RIEL DEL CAJÓN

RAIL  
 /FUEHRUNGSSCHIENE  
 /RAIL DE GUIDAGE  
 /GUIDA  
 /CARRIL DE GUÍA

Be careful to distinguish this drawer from the others.

/Achten Sie darauf, diese Schublade von den anderen zu unterscheiden.

/Faites attention à distinguer ce tiroir des autres.

/Fai attenzione a distinguere questa cassetta dagli altri.

/Tenga cuidado de diferenciar esta caja de los demás.

# STEP 28

## SCHRITT 28

### ÉTAPE 28

### PASSO 28

### PASO 28

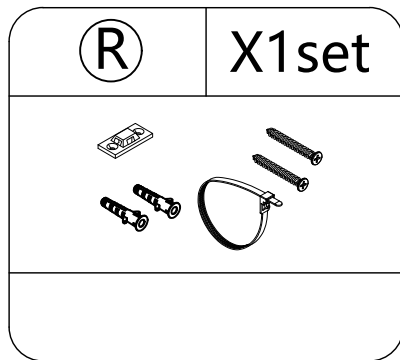

<b>⚠ WARNING</b>	
	<p><b>CHILDREN ARE KILLED BY FURNITURE TIPPOVER! TO REDUCE THE RISK OF FURNITURE TIPPOVER:</b></p> <ul style="list-style-type: none"> <li>• ALWAYS INSTALL THE PROVIDED ANTI-TIPPOVER KITS.</li> <li>• NEVER PUT A TV SET ON THIS PRODUCT!</li> <li>• NEVER ALLOW KIDS TO STAND, CLIMB OR HANG ON DRAWERS, DOORS OR SHELVES!</li> <li>• NEVER OPEN MORE THAN ONE DRAWER AT A TIME.</li> <li>• PLACE THE HEAVIEST ITEMS IN THE LOWEST DRAWERS.</li> </ul>

## INSTALL THE ANTI-TIP OVER KIT

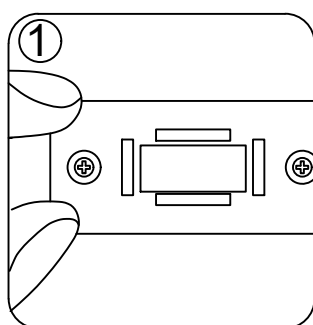

1. Measure the height of the previously installed part of the security device mounted to the back of the vanity table (see STEP 18) and make two marks on the wall for the drill holes holding for the wall mounted counter part. Make sure there are no power or water lines at the intended location of your drilling holes.

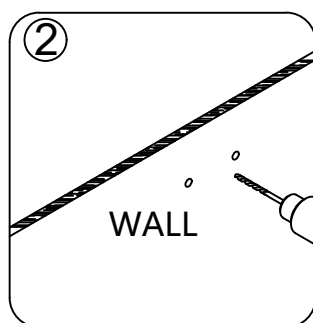
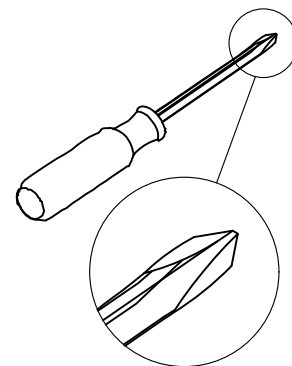

2. DRILL TWO  $\phi 6$  HOLES IN THE WALL WHERE YOU MADE THE MARKINGS.

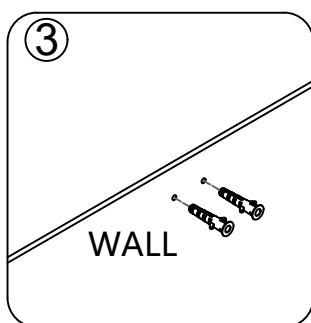

3. PUT THE ANCHORS INTO HOLES.

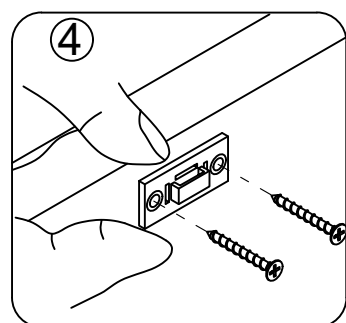

4. FIX THE ANTI-TIPPOVER DEVICE ON THE WALL

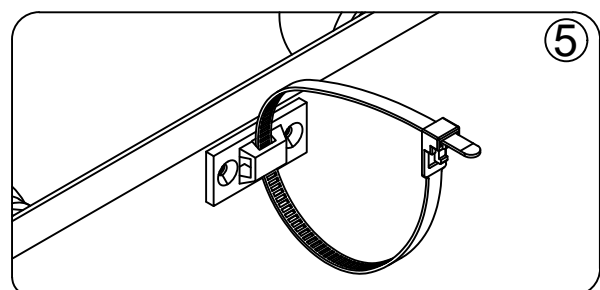

5. PUSH THE VANITY TABLE TOWARDS THE WALL AND CONNECT THE TWO PARTS OF THE ANTI-TIPPOVER KIT WITH THE ZIP TIE.

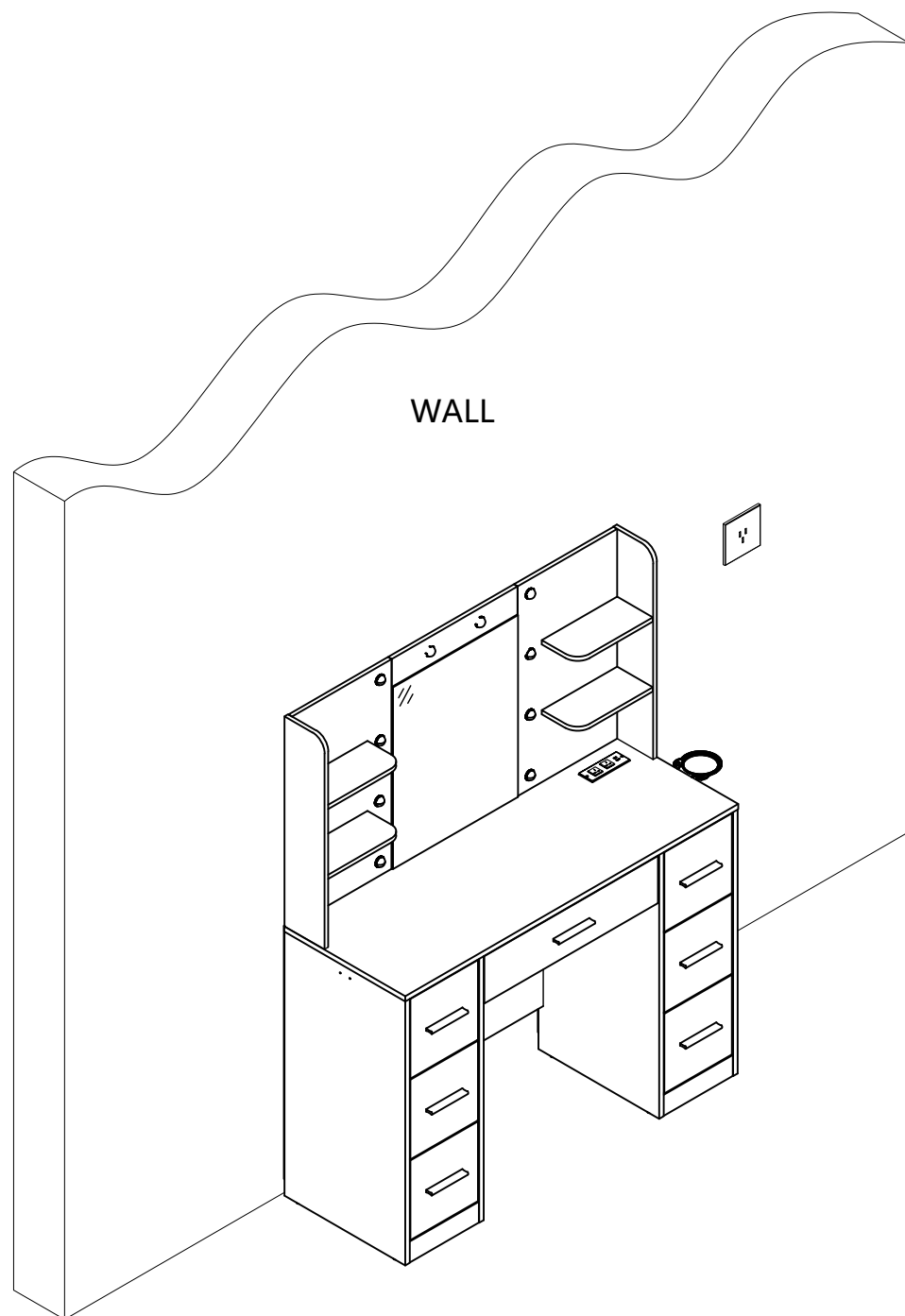

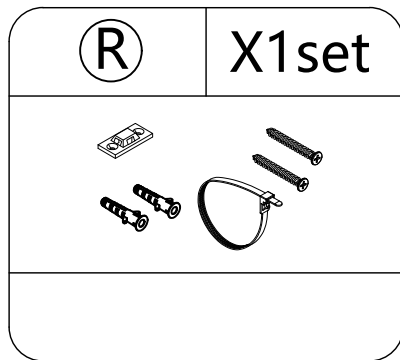

## ⚠ WARNHINWEIS!



**KINDER KOMMEN DURCH UMKIPPENDES MOBILIAR UMS LEBEN! REDUZIEREN SIE DAS RISIKO UMSTUERZENDER MOEBEL DURCH FOLGENDE MASSNAHMEN:**

- INSTALLIEREN SIE IMMER DIE MITGELIEFERTER KIPPSICHERUNG!
- STELLEN SIE NIEMALS EIN FERNSEHGERAET AUF DAS MOEBELSTUECK!
- ERLAUBEN SIE UNTER KEINEN UMSTAENDEN KINDERN AUF DAS MOEBELSTUECK ZU KLETTERN ODER SICH AN SCHUBLADEN, REGALE ODER TUEREN ZU HAENGEN!
- OEFFNEN SIE NIEMALS MEHRERE SCHUBLADEN GLEICHZEITIG
- VERSTAUEN SIE DIE SCHWERSTEN GEGENSTAENDE IN DEN UNTERSTEN SCHUBLADE



## ANBRINGEN DER KIPPSICHERUNG

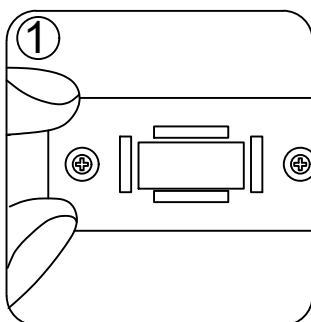

1. Messen Sie die Höhe des auf der Rückseite des Schminktisches in SCHRITT 18 angebrachte Teils der Kippsicherung und markieren Sie an der Wand zwei Bohrlocher fuer das dort anzubringende Gegenstück. Stellen Sie sicher das Sie beim Bohren der Loecher keine Versorgungsleitungen wie Strom oder Wasser beschaedigen.

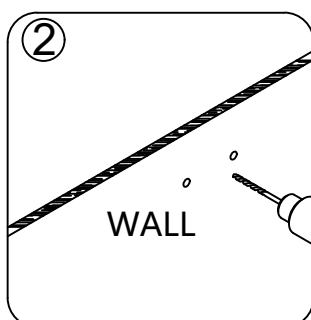
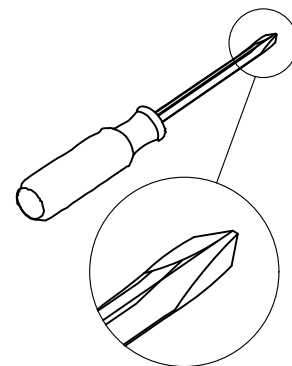

2. Bohren sie beiden Loechern  $\varnothing 6$

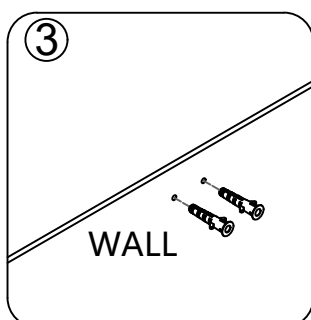

3. STECKEN SIE DIE DUEBEL IN DIE LOECHER

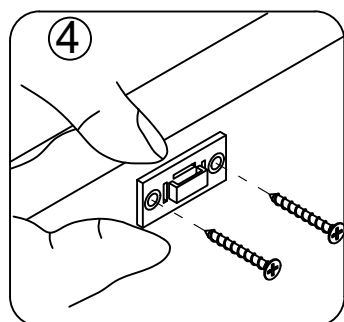

4. SCHRAUBEN SIE DIE WANDHALTERUNG DER KIPPSICHERUNG AN DER WAND FEST

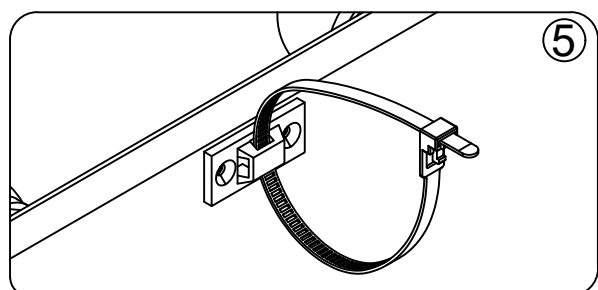

5. SCHIEBEN SIE DEN SCHMINKTISCH AN DIE WANFD UND VERBINDEN SIE DIE BEIDEN HALTERUNGEN DER KIPPSICHERUNG MIT DEM KABELBINDER.

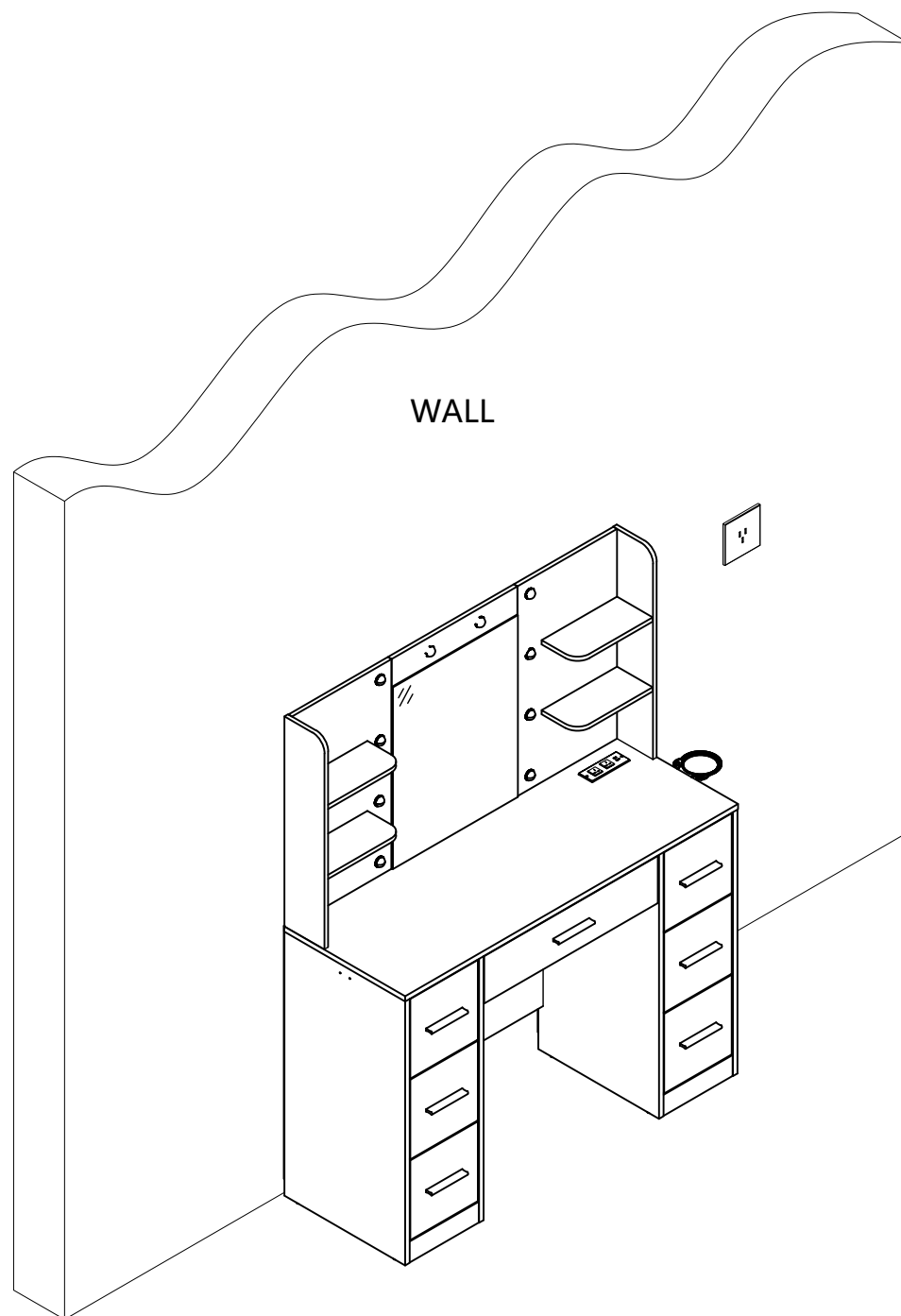

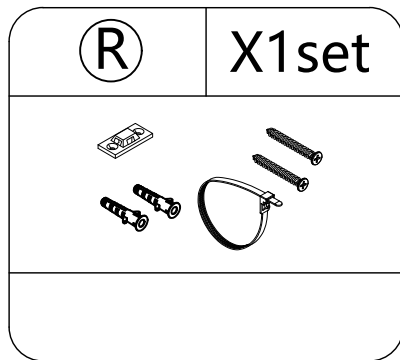

**⚠ AVERTISSEMENT!**

**DES ENFANTS SONT TUÉS PAR DES MEUBLES RENVERSÉS ! RÉDUIRE LE RISQUE DE COUVREMENTS DE MEUBLE GRÂCE AUX MESURES SUIVANTES :**

- TOUJOURS INSTALLER LA PROTECTION BASCULEMENT FOURNIE !
- NE JAMAIS PLACER UNE TV SUR LE MEUBLE !
- NE LAISSEZ EN AUCUN CAS LES ENFANTS MONTER SUR LES MEUBLES OU S'ACCROCHER AUX TIROIRS, ÉTAGÈRES OU PORTES !
- NE JAMAIS OUVRIR PLUSIEURS TIROIRS EN MÊME TEMPS
- METTRE LES OBJETS LOURDS DANS LE TIROIR DU BAS

## INSTALLATION DE LA PROTECTION ANTI-INCLINAISON

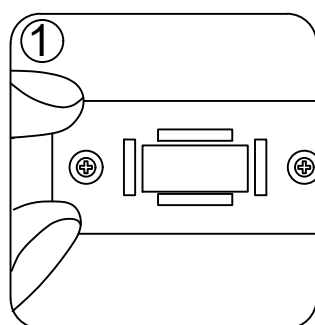

1. Mesurez la hauteur de la partie du dispositif anti-basculé fixée au dos de la coiffeuse à l'ÉTAPE 18 et marquez deux trous de perçage sur le mur pour y fixer la contrepartie. Assurez-vous de ne pas endommager les conduites d'alimentation telles que l'électricité ou l'eau lors du perçage des trous.

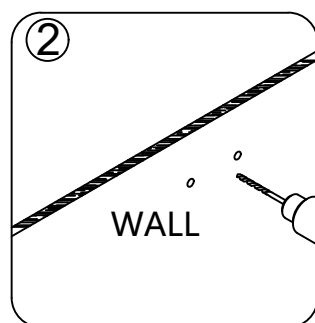
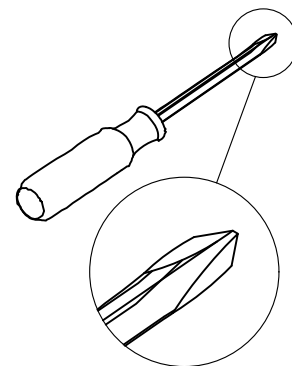

2. Percez les deux trous  $\varnothing 6$

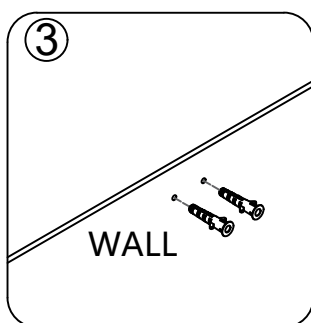

3. INSÉREZ LES CHEVILLES DANS LES TROUS

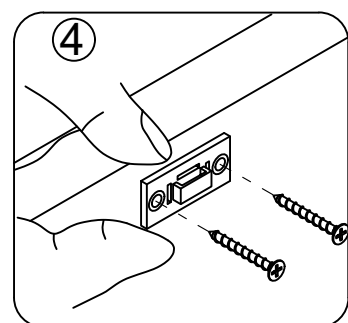

4. VISSER LE SUPPORT MURAL ANTI-INCLINAISON AU MUR

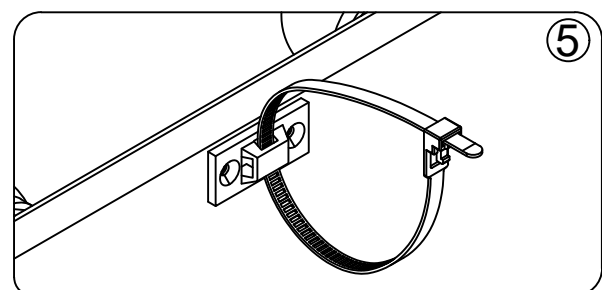

5. GLISSEZ LA COIFFEUSE AU MUR ET CONNECTEZ LES DEUX SUPPORTS DE PROTECTION BASCULANT AVEC L'ATTACHE-CÂBLE.

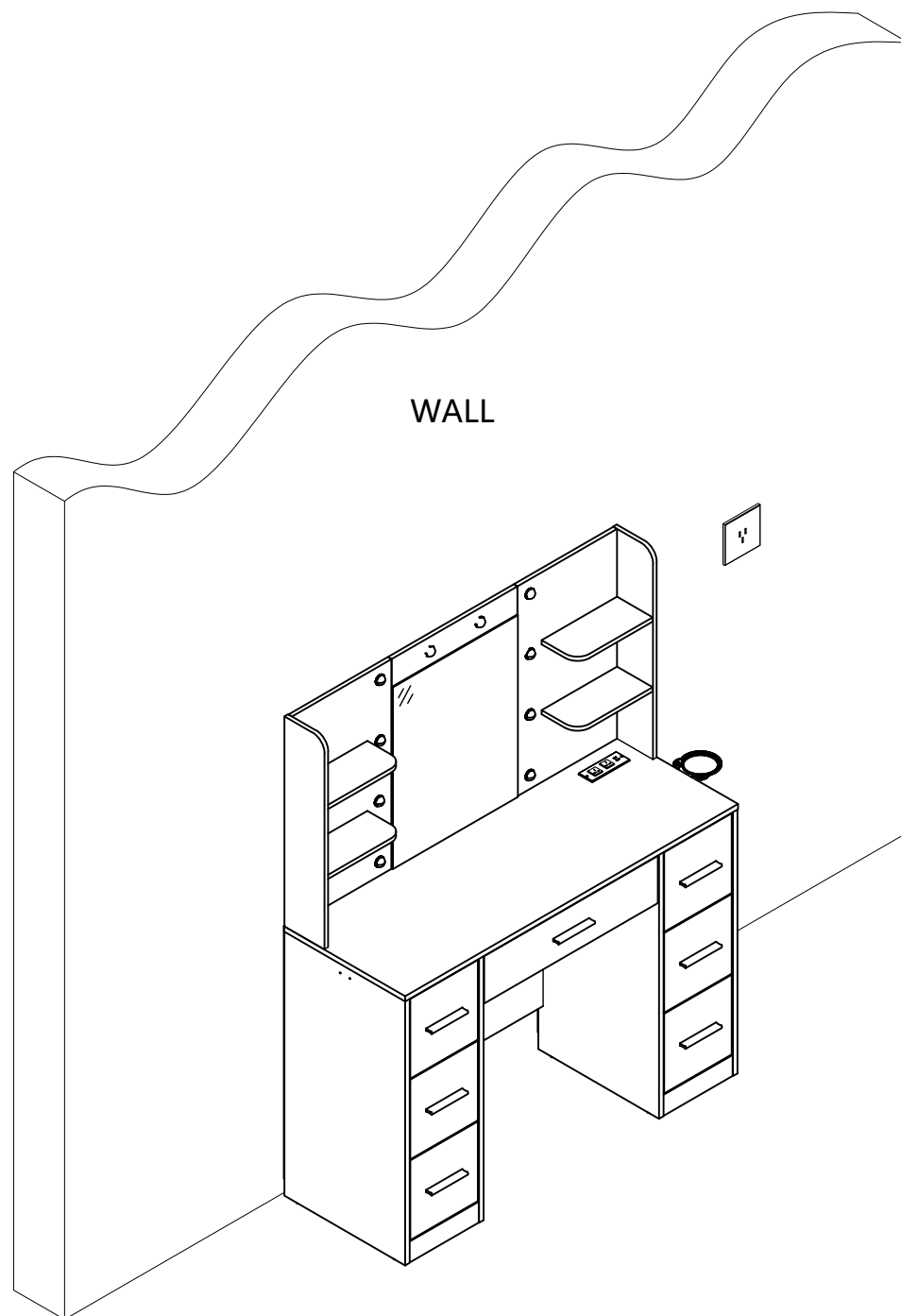

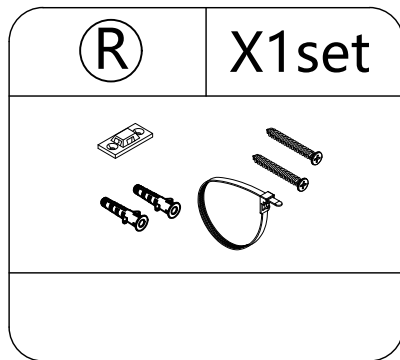

**⚠ AVVERTIMENTO!**

**I BAMBINI VENGONO UCCISO PER IL RIBALTAMENTO DEI MOBILI! RIDURRE IL RISCHIO DI RABBOCCO DEI MOBILI ATTRAVERSO LE SEGUENTI MISURE:**

- INSTALLARE SEMPRE LA PROTEZIONE RIBALTABILE IN DOTAZIONE!
- NON POSIZIONARE MAI LA TV SUL MOBILE!
- NON PERMETTERE IN NESSUN CASO AI BAMBINI DI ARRAMPICARSI SUI MOBILI O DI APPENDERSI A CASSETTI, RIPIANI O PORTE!
- NON APRIRE MAI PIÙ CASSETTI CONTEMPORANEAMENTE
- METTERE GLI OGGETTI PESANTI NEL CASSETTO INFERIORE

## INSTALLAZIONE DELLA PROTEZIONE INCLINAZIONE

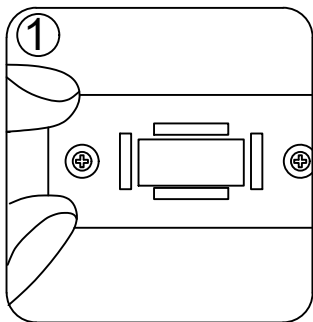
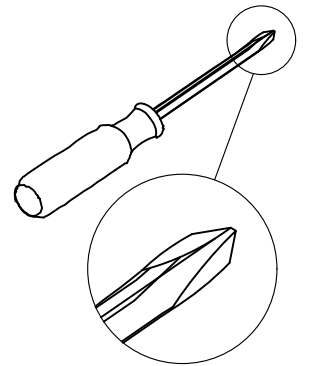

1. Misurare l'altezza della parte del dispositivo antiribaltamento fissata sul retro della toeletta al PUNTO 18 e segnare due fori sulla parete per fissare lì la controparte. Assicurarsi di non danneggiare le linee di alimentazione come elettricità o acqua durante la pratica dei fori.

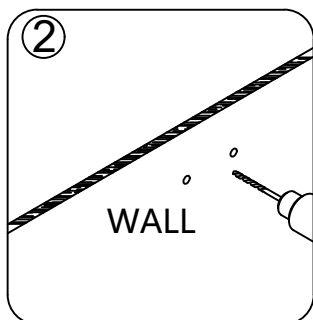

2. Eseguire entrambi i fori  $\varnothing 6$

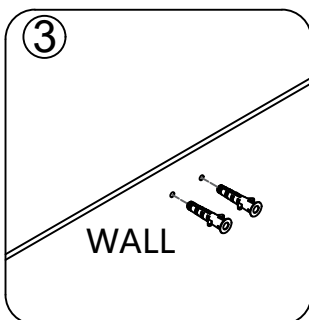

3. INSERIRE I TASSELLI NEI FORI

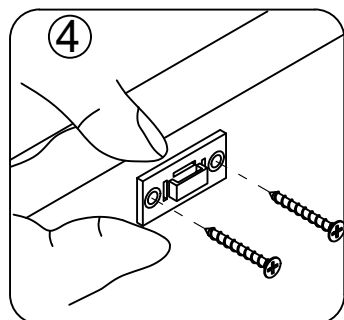

4. AVVITARE IL SUPPORTO DA PARETE ANTI-INCLINAZIONE ALLA PARETE

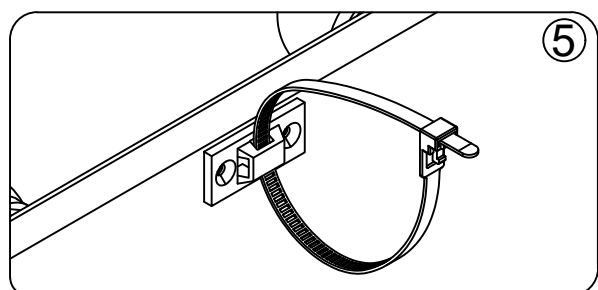

5. FAR SCORRERE IL TAVOLINO ALLA PARETE E COLLEGARE LE DUE STAFFE DI PROTEZIONE INCLINABILI CON LA FASCETTA.

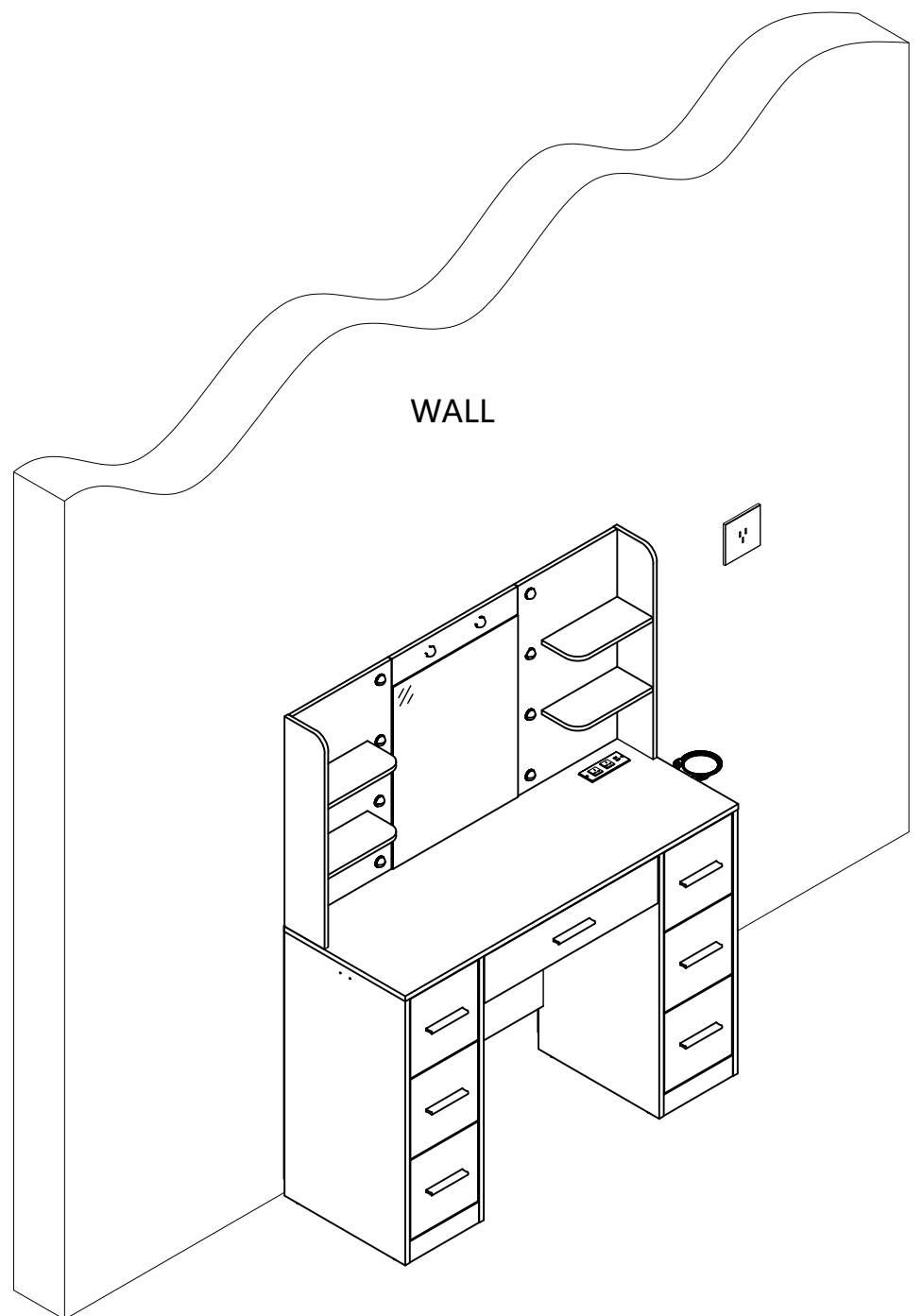

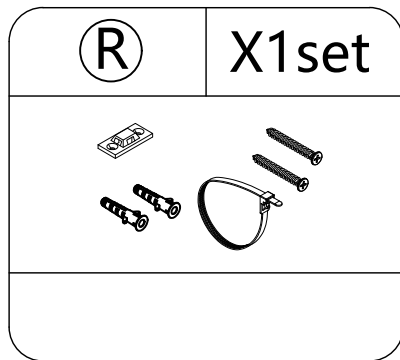

**⚠ ¡ADVERTENCIA!**

**¡LOS NIÑOS MUEREN AL VUELCO DE LOS MUEBLES! REDUZCA EL RIESGO DE COBERTURA DE MUEBLES MEDIANTE LAS SIGUIENTES MEDIDAS:**

- ¡INSTALE SIEMPRE LA PROTECCIÓN INCLINADA PROPORCIONADA!
- ¡NUNCA COLOQUES UN TELEVISOR SOBRE EL MUEBLE!
- ¡BAJO NINGUNA CIRCUNSTANCIA NO PERMITA QUE LOS NIÑOS SE SUBEN A LOS MUEBLES O SE CUELGUEN DE CAJONES, ESTANTES O PUERTAS!
- NUNCA ABRA VARIOS CAJONES AL MISMO TIEMPO
- PON LOS ARTÍCULOS PESADOS EN EL CAJÓN INFERIOR

## INSTALACIÓN DE LA PROTECCIÓN DE INCLINACIÓN

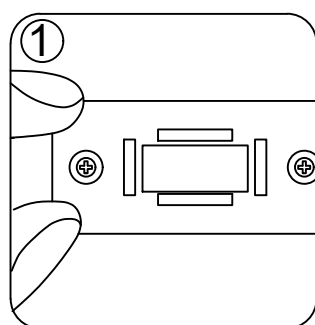

1. Mida la altura de la parte del dispositivo antivuelco colocado en la parte posterior del tocador en el PASO 18 y marque dos orificios en la pared para colocar la contraparte allí. Asegúrese de no dañar ninguna línea de suministro, como electricidad o agua, al perforar los agujeros.

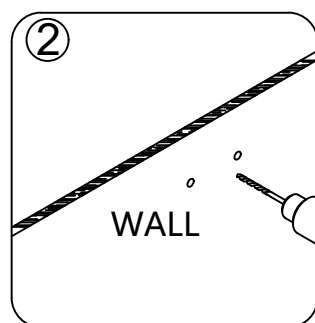
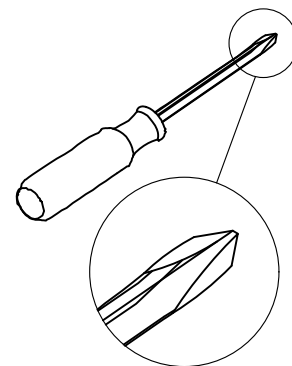

2. Perfore ambos agujeros  $\varnothing 6$

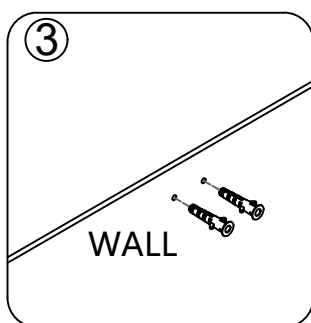

3. INSERTE LAS CLAVIJAS EN LOS AGUJEROS

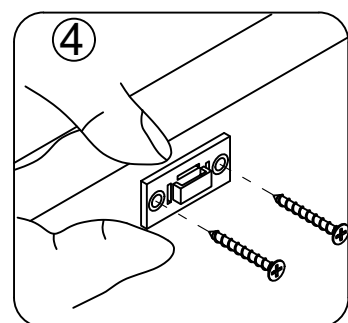

4. Atornille el soporte de pared antivuelco a la pared.

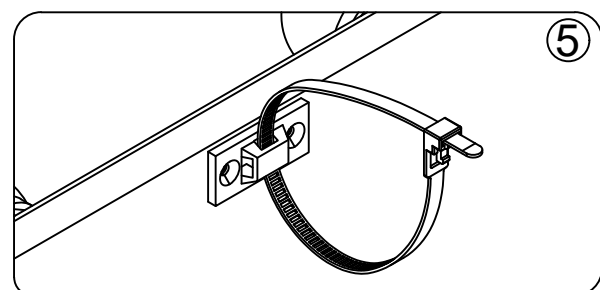

5. DESLIZA EL TOCADOR A LA PARED Y CONECTA LOS DOS SOPORTES DE PROTECCIÓN INCLINABLE CON LA BRIDA.

