

ASSEMBLY INSTRUCTION

Polyester Sofa

READ THIS INSTRUCTIONS CAREFULLY. SEE FURNITURE HARDWARE AND PART LIST FOR GUIDANCE. BE SURE ALL PARTS ARE COMPLETE BEFORE YOU ASSEMBLE. FOLLOW THE FIGURE TO START ASSEMBLING. AT LEAST TWO PEOPLE ARE REQUIRED TO ASSEMBLE THIS PRODUCT.



NOTE: SOME PARTS & HARDWARES ARE STORED INSIDE VELCRO COMPARTMENT OF THE BASE. THE LIST AND QUANTITY SHOWN ARE FOR 1 UNIT ASSEMBLY.

CAUTIONS:

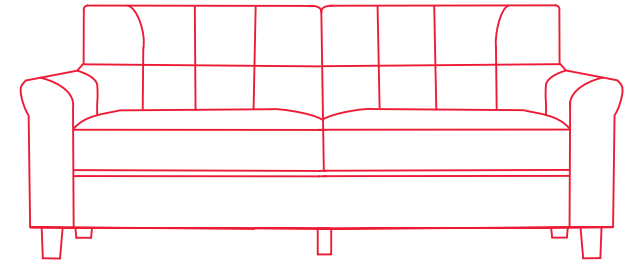

1. DO NOT USE A POWER TOOL-to assemble this product. Its use may damage to the thread.
2. DO NOT FULLY-Tighten the nut or bolt until all nut or bolt is ready assembled.
3. DO NOT OVER-Tighten the nut or bolt to avoid causing damages to the thread.
4. Keep all hardware parts out of reach of children.

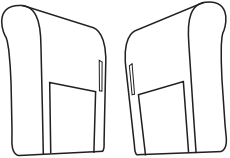
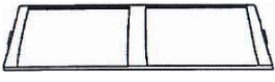
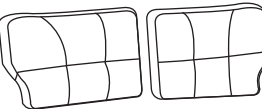
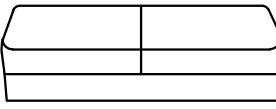

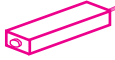
PART LIST

<p>A. Armrest</p>  <p>2 PCS</p>	<p>B. Backrest</p>  <p>1 PC</p>	<p>C. Back Cushion</p>  <p>2 PCS</p>	<p>D. Base</p>  <p>1 PC</p>	<p>E. Leg</p>  <p>4 PCS</p>	<p>J. Support Leg</p>  <p>1 PCS</p>
--	--	--	--	--	--

HARDWARE LIST (IN ACTUAL SIZE/SCALE FOR REFERENCE)

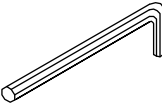
<p>F. Spring Washer</p>  <p>6 PCS</p>	<p>G. Flat Washer</p>  <p>6 PCS</p>	<p>H. Bolt (M8x50mm)</p>  <p>6 PCS</p>	<p>I. Allen Wrench</p>  <p>1 PC</p>
--	--	--	--

ATTENTION:

THIS ITEM SHOULD BE ASSEMBLED ON A SOFT SURFACE TO PREVENT SCRATCHING DURING ASSEMBLY.

STEP 1 : Open the velcro at the bottom of the Base (D) then take out the Armrest (A), Back Cushion (C), and Hardware (F/G/H/I).

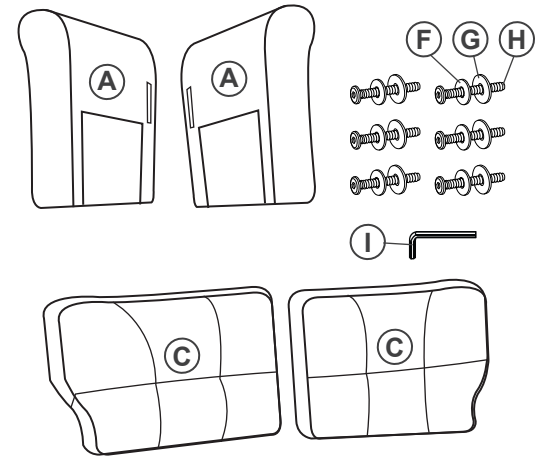
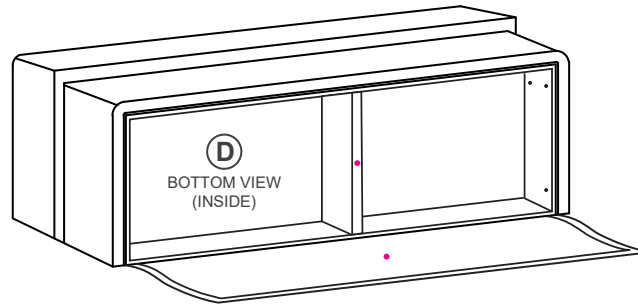
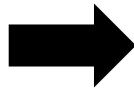
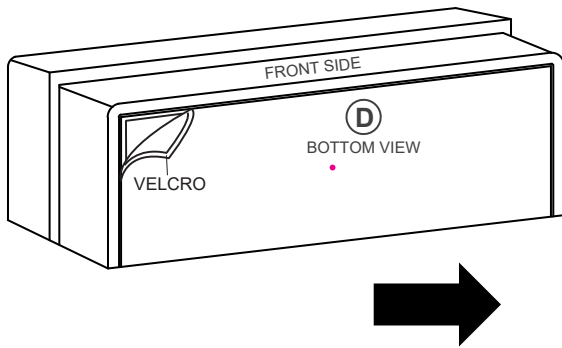

STEP 2 : Insert the Leg (E) to the hole on the bottom of Armrest (A) and twist clock wise to secure.

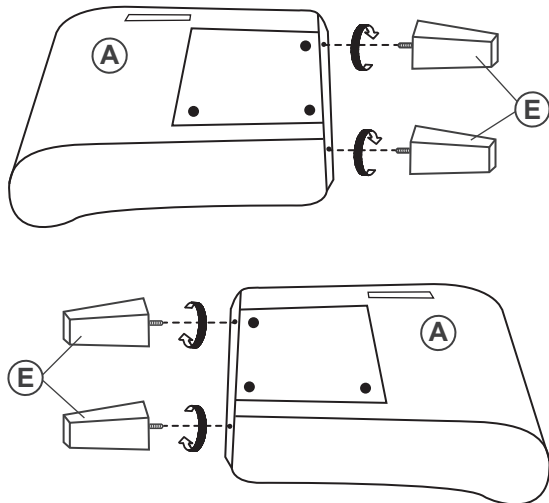

STEP 3 : Align the holes on the Armrest to the side of Base (D) and secure by inserting Bolt (H) with Spring Washer (F), Flat Washer (G) from inside the Base (D) as shown on picture.

⚠ NOTE:

Make sure to CLOSE the cover and fasten by pressing velcro strip to secure, BEFORE inserting Support Leg (J) and tighten by rotating clock wise.

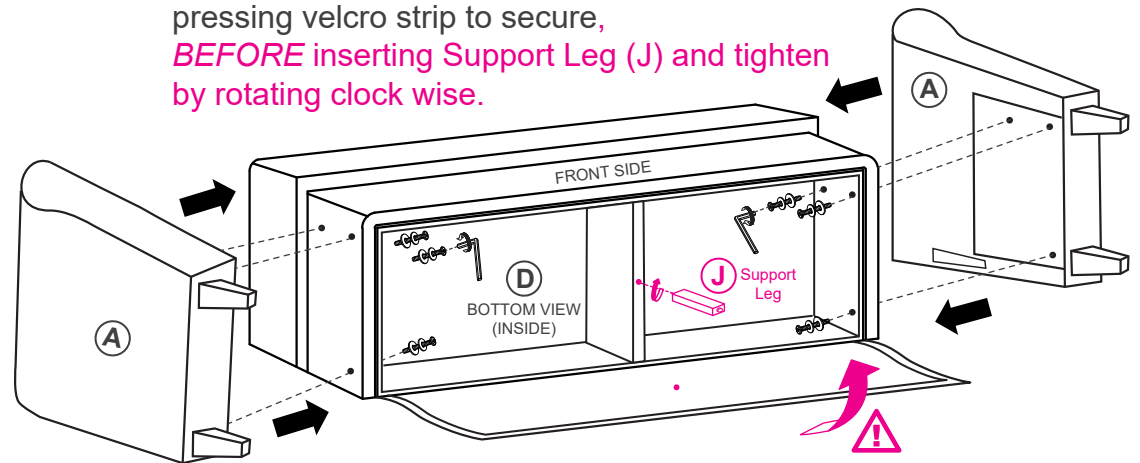
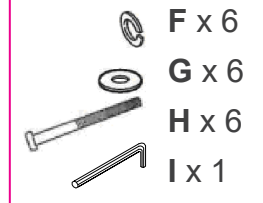

STEP 4 : Attach the Backrest (B) to the back of Base (C) by aligning the metal brackets on the side of Backrest (B) to Armrest (A) and push them down until clicked.

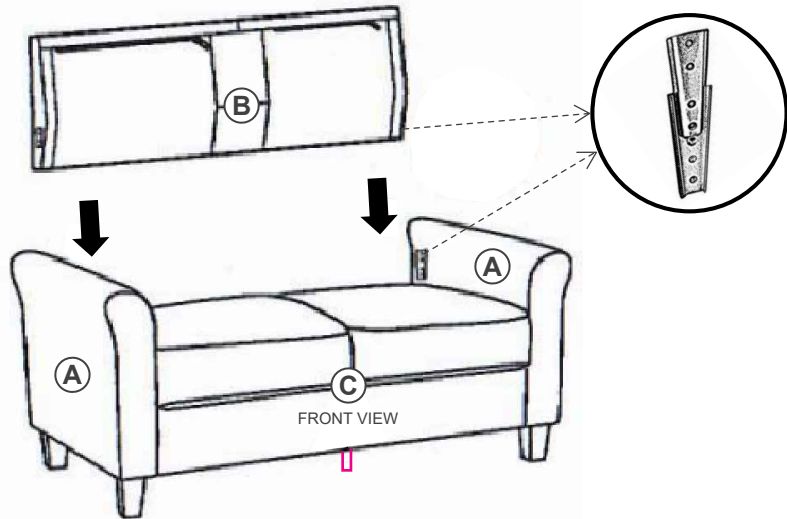

STEP 5 : Place the Back Cushion (C) against the Backrest (B). See picture.

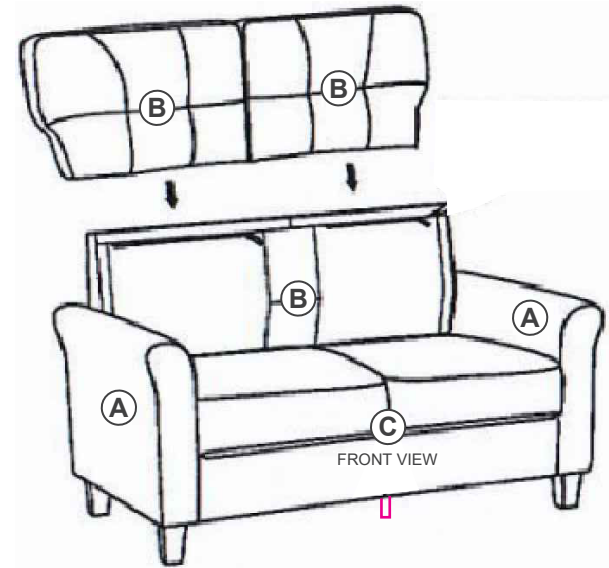

ASSEMBLY COMPLETED

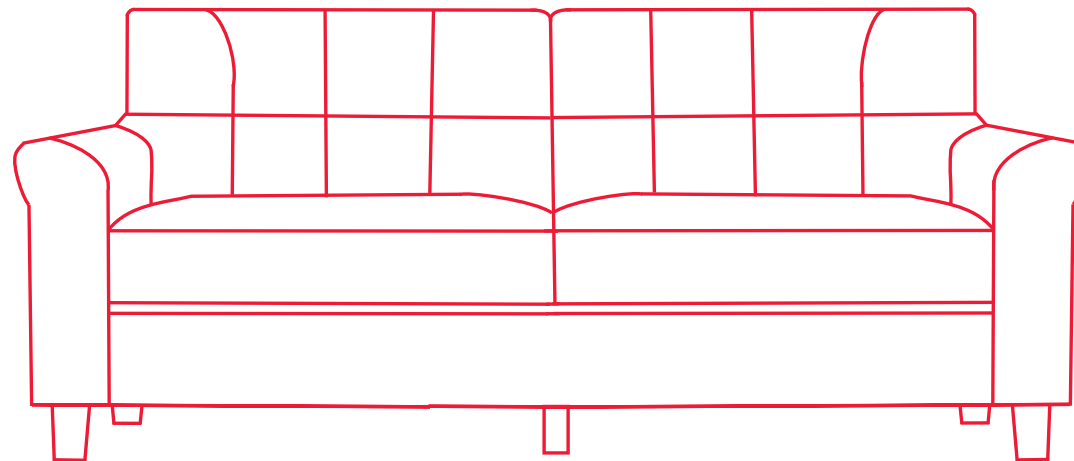

Your sofa is now ready!
DO NOT Jump or Stand on top!