

NOTICE

- *Please make sure that you have all parts indicated and they are in good condition before you begin assembly of this item. Refer to part list and hardware list below for guidance.
- *This item should be assembled on a soft surface to prevent scratching the finish during assembly.
- *This item may require periodic tightening.
- *If you are having difficulty, our friendly Customer Care team is always here to help. Please email











PREPARATION

- *Before beginning assembly of product, make sure all parts are present. Compare parts with part contents list and hardware contents list.
- *If any part is missing or damaged, do not attempt to assemble the product.
- *EstimatedAssemblyTime:30minutes.
- * ToolsRequiredforAssembly(included):AllenKey

CARE AND MAINTENANCE

- *All associated cushions should be stored indoors in a dry clean environment when not in use.

Part List and Hardware List

PIECE	DESCRIPTION	PICTURE	QUANTITY
A	Chair		2
B	Foreleg		6
C	Hindleg		6
D	Loveseat		1
E	TableLeg		4
F	TableTop		1
G	TableGlass		1
HW1	Hexagon Socket Screw 6x0.5x150mm		48
HW2	Flat Washer 6mm		48
HW3	Allen Key		1

ItemDimension

1Seater : 30.22"x33.33"x31.56"
2Seater : 56"x33.33"x31.56"
Table : 40"x24.44"x17.78"

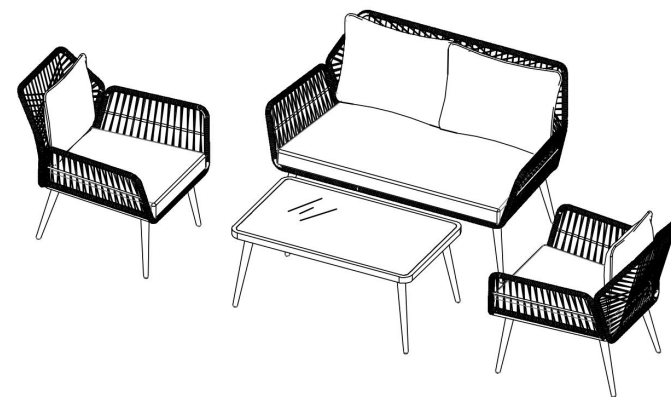

Weight Capacity :

1Seater:220LBS

2Seater:440LBS

Table:110LBS

Warning: Do not stand on item

Warning: Do not over torque bolts

PREPARATION

*Before beginning assembly of product, make sure all parts are present. Compare parts with part contents list and hardware contents list. *If any part is missing or damaged, do not attempt to assemble the product.

*Estimated Assembly Time: 20 minutes.

*Tools Required for Assembly (included): Allen Key

*If you are having difficulty, our friendly Customer Care team is always here to help.

*Gradually tighten bolts in a star pattern: tighten one bolt and then the one opposite from it until all bolts are tightened.

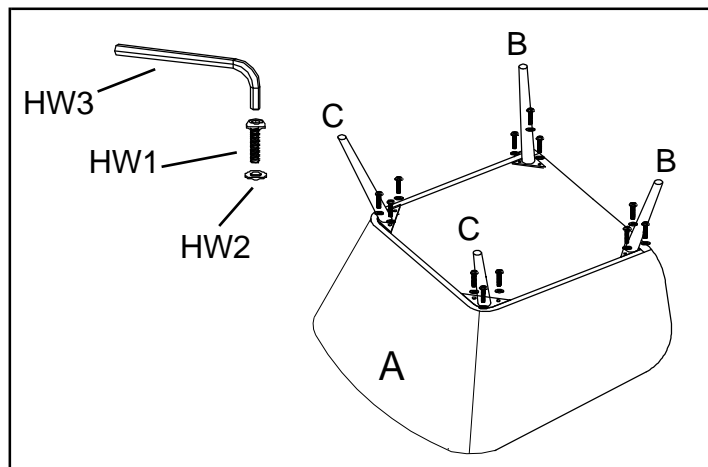

STEP1:
Assemble the chair leg(B)and leg (C) to the chair(A), using bolt and washer(HW1&HW2) and Allen key(HW3).

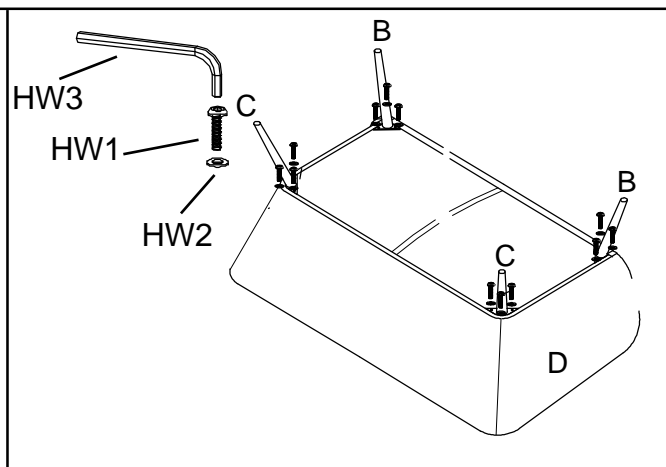

STEP2:
Assemble the Seater leg(B) and leg(C) to the Seater(D), using bolt and washer(HW1&HW2) and Allen key(HW3).

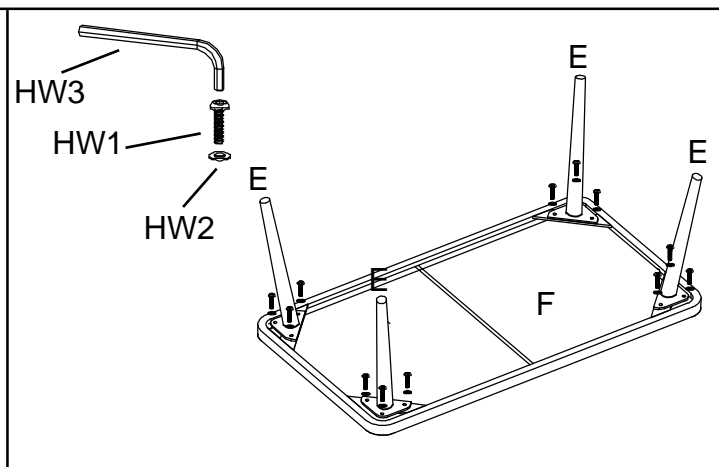

STEP3:
Assemble the table leg(E) to the table top(F), using bolt washer(HW1&HW2) and Allen key(HW3).

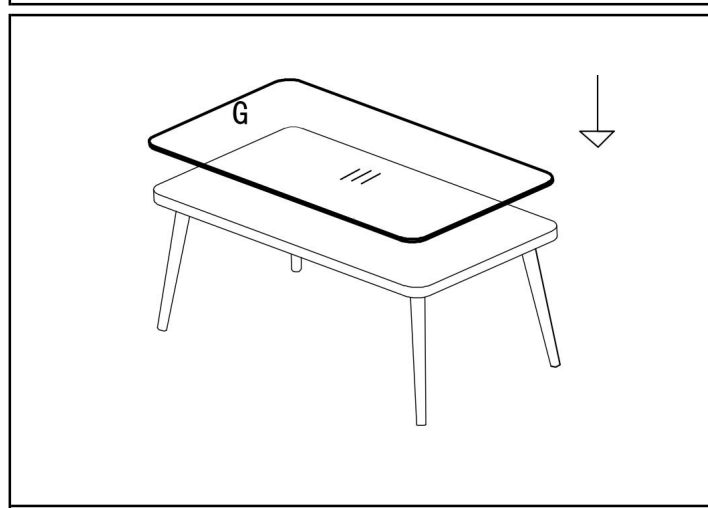

STEP4:
Put the glass on the top.