

# ASSEMBLY INSTRUCTIONS / INSTRUCTIONS DE MONTAGE





## ROUND TABLE / TABLE RONDE

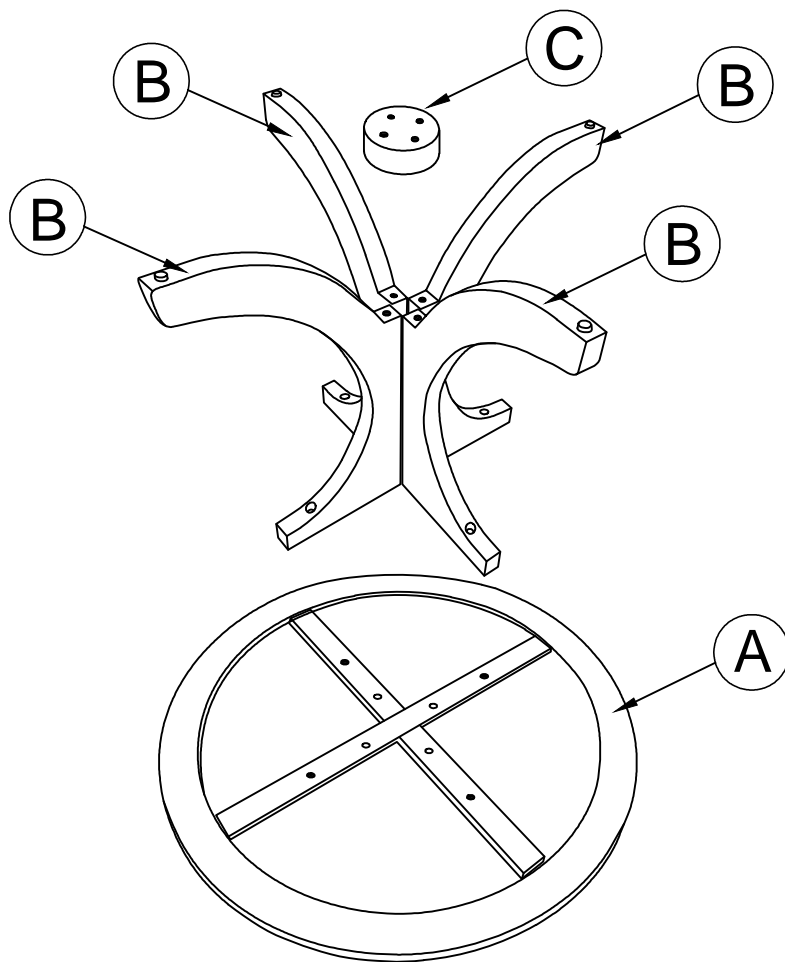

### **IMPORTANT NOTE :**

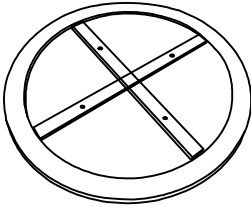
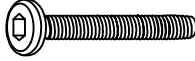
- ① PLACE ALL PARTS ON A CLEAN AND SMOOTH SURFACE SUCH AS A RUG OR CARPET TO AVOID THE PARTS FROM BEING SCRATCHED .  
PLACEZ TOUTES LES PIÈCES SUR UNE SURFACE PROPRE ET LISSE COMME UN TAPIS OU UN CARPET POUR ÉVITER QUE LES PIÈCES SONT ÉCARTÉES.
- ② BEFORE YOU BEGIN , KINDLY FOLLOW THE ASSEMBLY INSTRUCTIONS STEP BY STEP  
AVANT DE COMMENCER, VEUILLEZ SUIVRE LES INSTRUCTIONS D'ASSEMBLAGE ÉTAPE PAR ÉTAPE
- ③ DO NOT TIGHTEN ALL SCREWS AND BOLTS UNTILL THE TABLE FULLY SET-UP  
NE SERREZ PAS TOUTES LES VIS ET TOUS LES BOULONS AVANT QUE LA TABLE SOIT COMPLÈTEMENT INSTALLÉE.

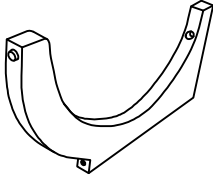

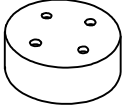
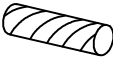
Parts List For One / Liste Des pièces			Hardware List For One / Trousse De Quincaillerie		
NO.	Part Description (Liste des pie ces)	Q'ty/ Qte	NO.	Hardware Description (Description du matériel)	Q'ty/ Qte
A	Table top (Plateau de table) 	1pc	1	 Bolts / Boulon 5/16" x 60mm	4pcs
			2	 Bolts / Boulon 5/16" x 40mm	4pcs
			3	 Spring Washer / Rondelle ressort 5/16" x 13mm x 1.5mm	8pcs
B	Legs (Jambes) 	4pcs	4	 Flat Washer / Rondelle plate 5/16"* 19mm x 1.5mm	8pcs
			5	 Allen Key / Clé Allen	1pc
C	Support Wood (Bois Support) 	1pcs	6	 Dowel / Goujon Ø10 x 40mm	4pcs

# STEP 1 (ÉTAPE 1)

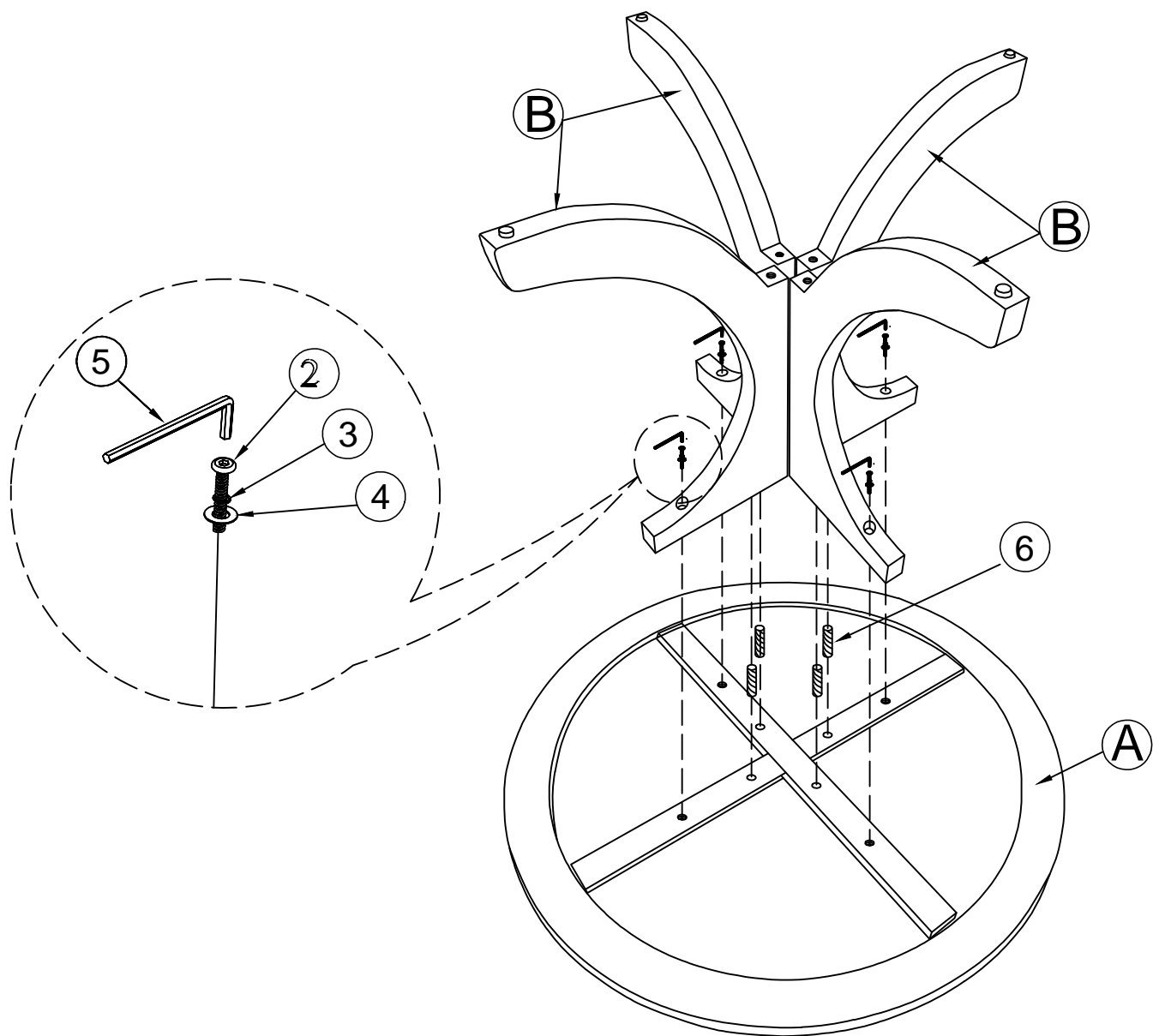

## STEP 2 (ÉTAPE 2)

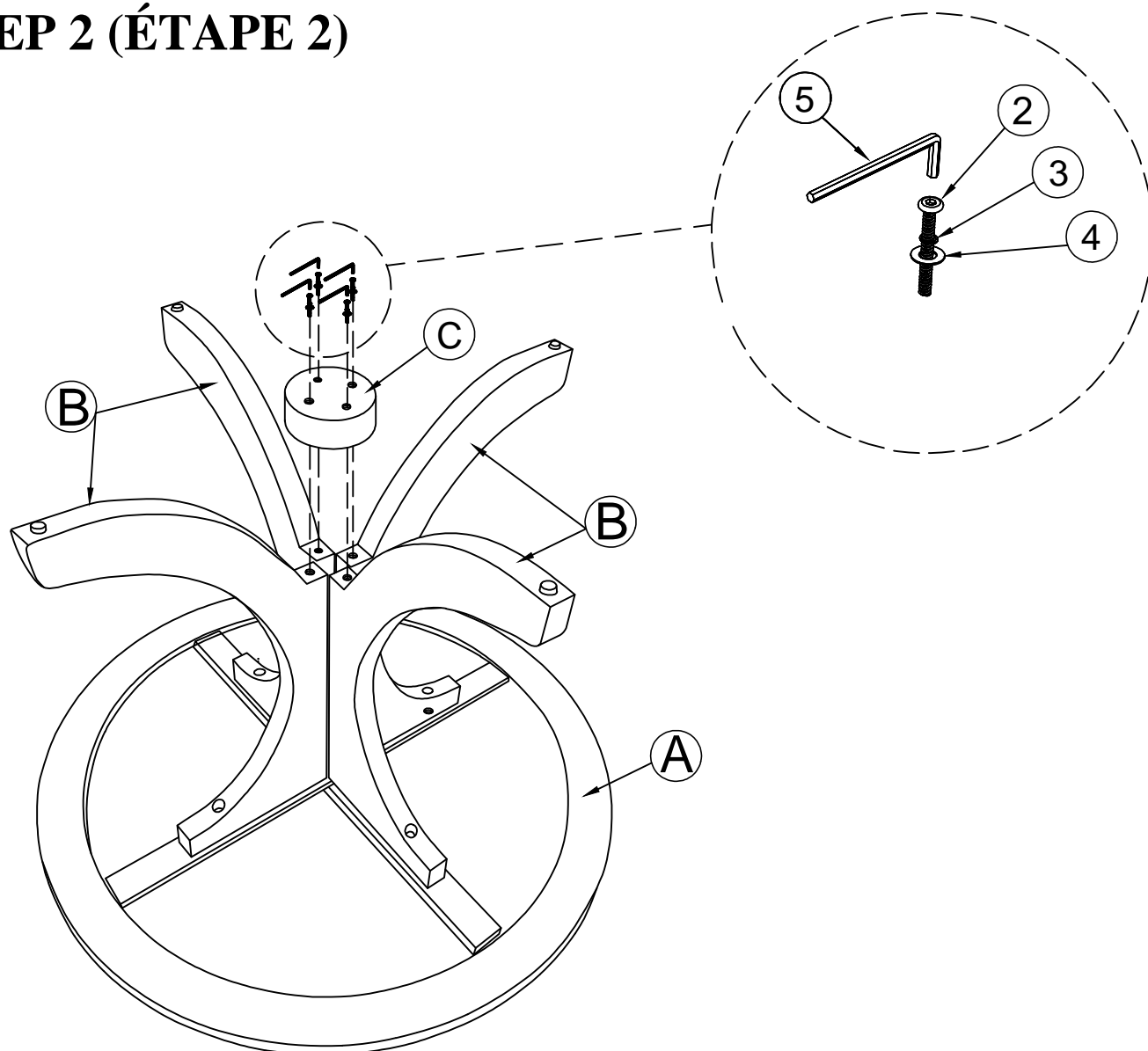

## STEP 3 (ÉTAPE 3)



# ASSEMBLY INSTRUCTIONS / INSTRUCTIONS DE MONTAGE

## DINING CHAIR / CHAISE DE SALLE À MANGER

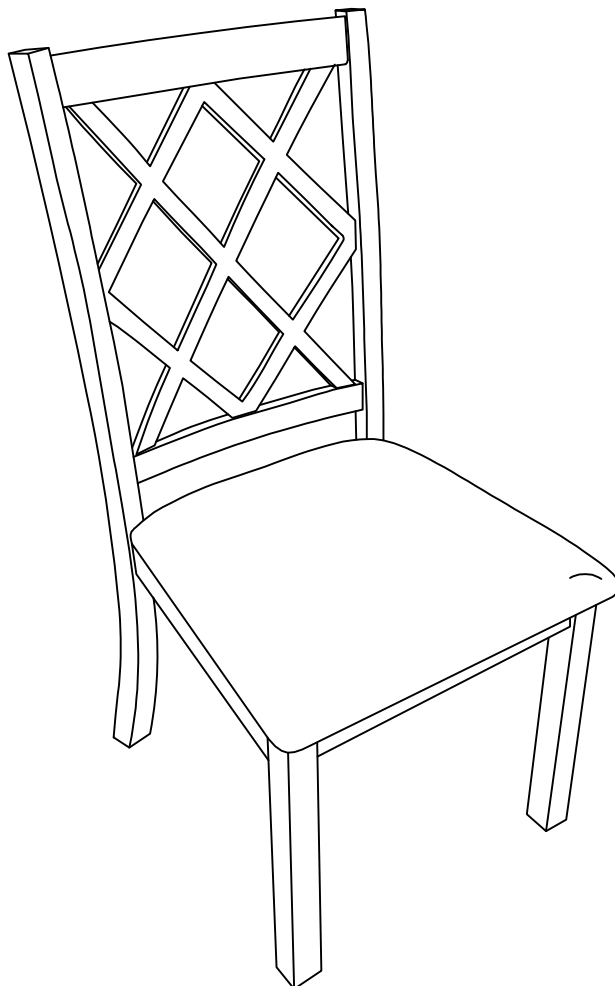





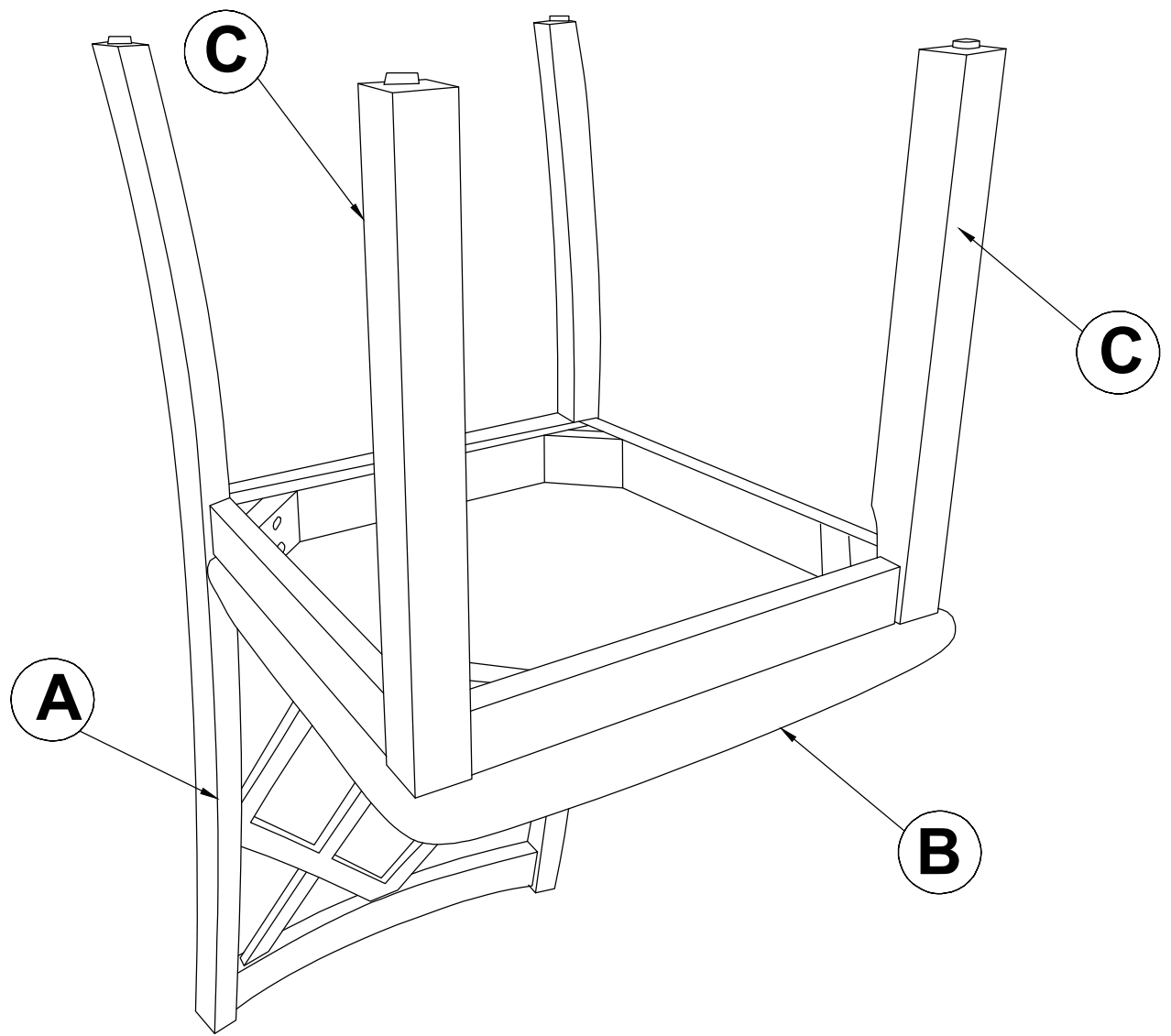

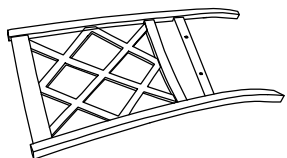

### **IMPORTANT NOTE :**

- ① PLACE ALL PARTS ON A CLEAN AND SMOOTH SURFACE SUCH AS A RUG OR CARPET TO AVOID THE PARTS FROM BEING SCRATCHED .  
PLACEZ TOUTES LES PIÈCES SUR UNE SURFACE PROPRE ET LISSE COMME UN TAPIS OU UN CARPET POUR ÉVITER QUE LES PIÈCES SONT ÉCARTÉES.
- ② BEFORE YOU BEGIN , KINDLY FOLLOW THE ASSEMBLY INSTRUCTIONS STEP BY STEP  
AVANT DE COMMENCER, VEUILLEZ SUIVRE LES INSTRUCTIONS D'ASSEMBLAGE ÉTAPE PAR ÉTAPE
- ③ DO NOT TIGHTEN ALL SCREWS AND BOLTS UNTILL THE CHAIR FULLY SET-UP  
NE SERREZ PAS TOUS LES VIS ET BOULONS JUSQU'À CE QUE LE CHAISE SOIT COMPLÈTEMENT INSTALLÉ.

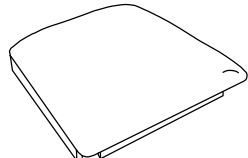

**PARTS LIST FOR ONE / LISTE DES PIÈCES**

**Hardware List For One / Trousse De Quincaillerie**

NO.	Part Description (Liste des pie ces)	Q'ty/ Qte	NO.	Hardware Description (Description du matériel)	Q'ty/ Qte
A	BACK FRAME (CADRE ARRIÈRE) 	1pc	1	Bolt / Boulon 1/4" * 35 mm 	2pcs
			2	Bolt / Boulon 1/4" * 50 mm 	4pcs
			3	Bolt / Boulon 1/4" * 70 mm 	4pcs
B	SEAT FRAME (CADRE DE SIÈGE) 	1pc	4	Spring Washer / Rondelle plate  1/4 * 11mm * 1.5 mm	10pcs
			5	Flat Washer / Rondelle plate  1/4 * 19mm * 1.5 mm	10pcs
C	FRONT LEGS (JAMBE AVANT) 	2pcs	6	Allen Key / Clé Allen  4mm * 60 mm	1pc

**STEP 1/ (ÉTAPE 1)**

**STEP 2/ (ÉTAPE 2)**

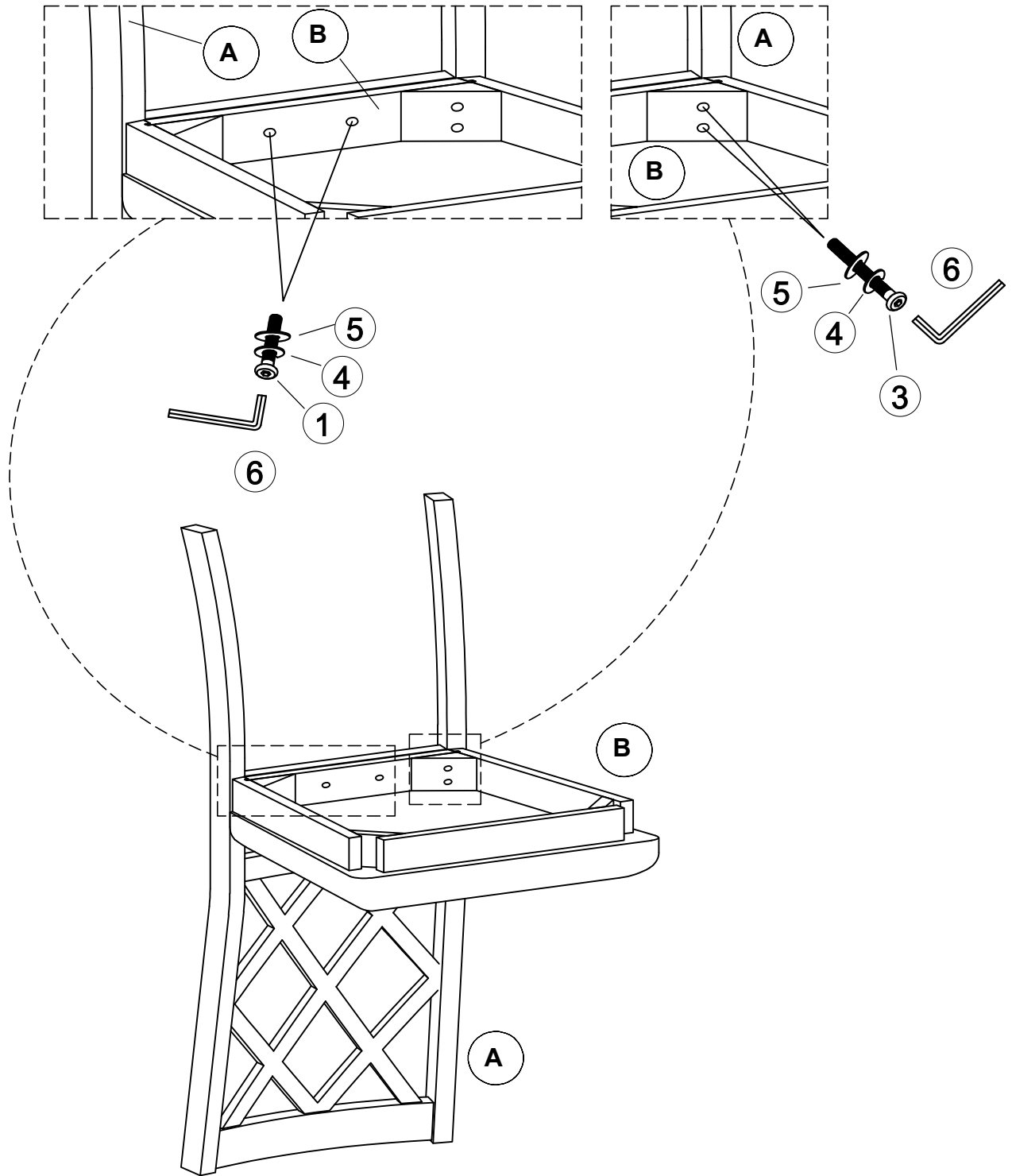

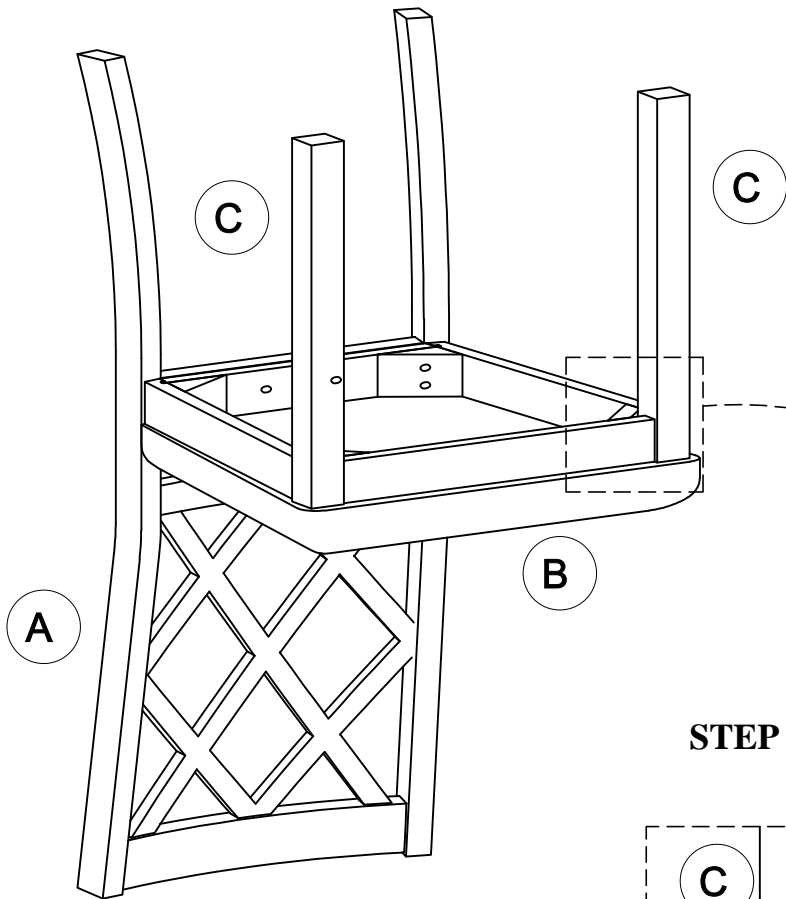

**STEP 3/ (ÉTAPE 3)**

