

# ASSEMBLY INSTRUCTIONS

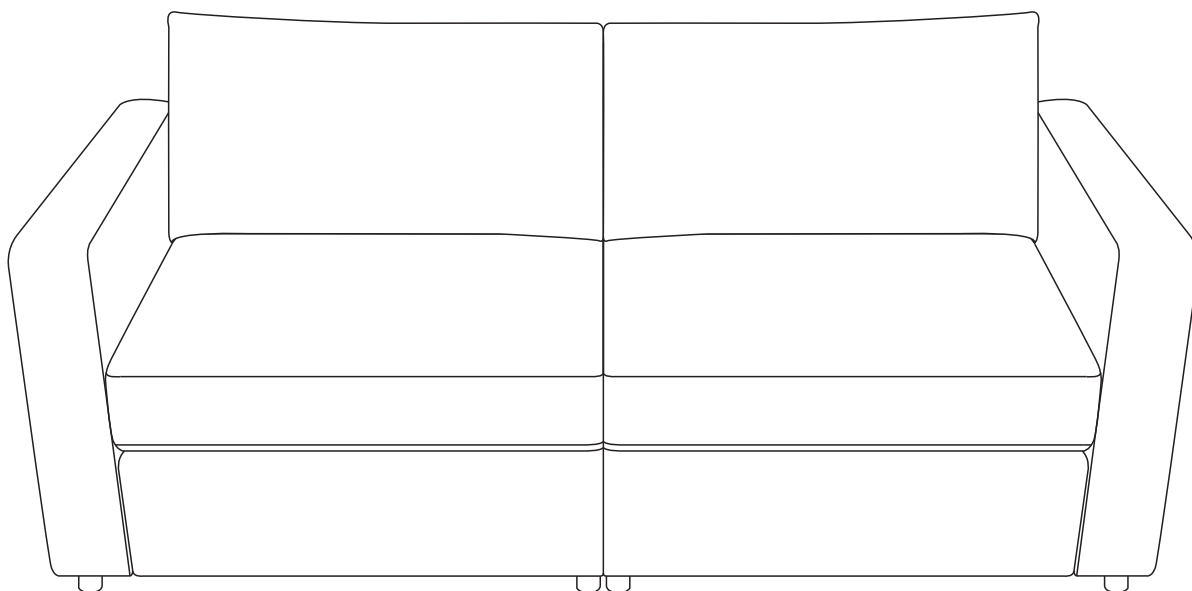

TIME



2 OF PEOPLE



DIFFICULTY

## NOTICE

### Instruction Booklet - Important Safety Information

Thank you for choosing our product. Please review this booklet carefully for essential safety information and keep it for future reference.





- Upon receiving the product, ***ensure all parts are present and intact*** before proceeding with installation. Follow the entire installation instructions provided.
- During installation, exercise caution and refrain from immediately tightening screws. Secure all screws to 80% before final tightening.
- The item has been divided into **2** packages. If your multi-package order does not arrive simultaneously, please allow 1-3 working days for the remaining package to arrive promptly.
- Note: Cushions are ***compressed*** and cannot be recompressed once opened. Returns are accepted only for items in their ***original, unopened condition***.



**Before installation, please check that the parts are all included !**

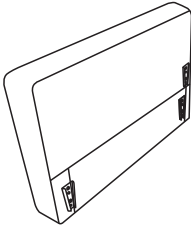
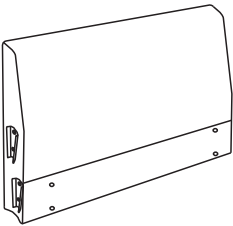
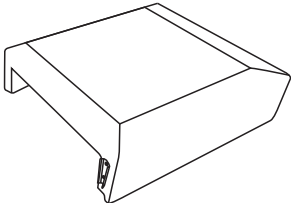

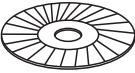
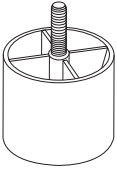
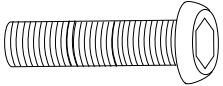
# Carton A

Materials ▶

			
Handrail ① x1	Backrest ② x1	Seat frame ③ x1	Back Cushion ④ x1
			
Cushion ⑤ x1	Plastic gasket ⑥ x4	Sofa Feet ⑦ x4	M6x45mm Ax8
			
1.6*0.6*0.1 Bx8	Cx1		

# Carton B

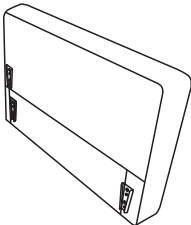
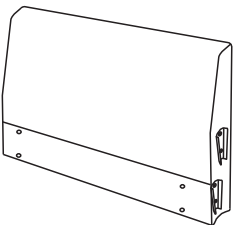
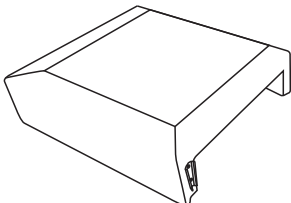
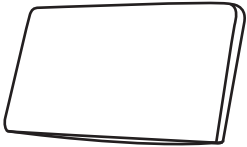
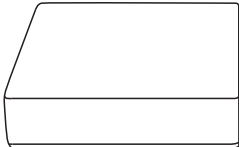
Materials ▶

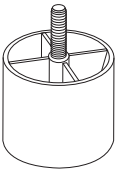
			
Handrail ⑧ x1	Backrest ⑨ x1	Seat frame ⑩ x1	Back Cushion ④ x1
			
Cushion ⑤ x1	Plastic gasket ⑥ x4	Sofa Feet ⑦ x4	

# Installation Steps

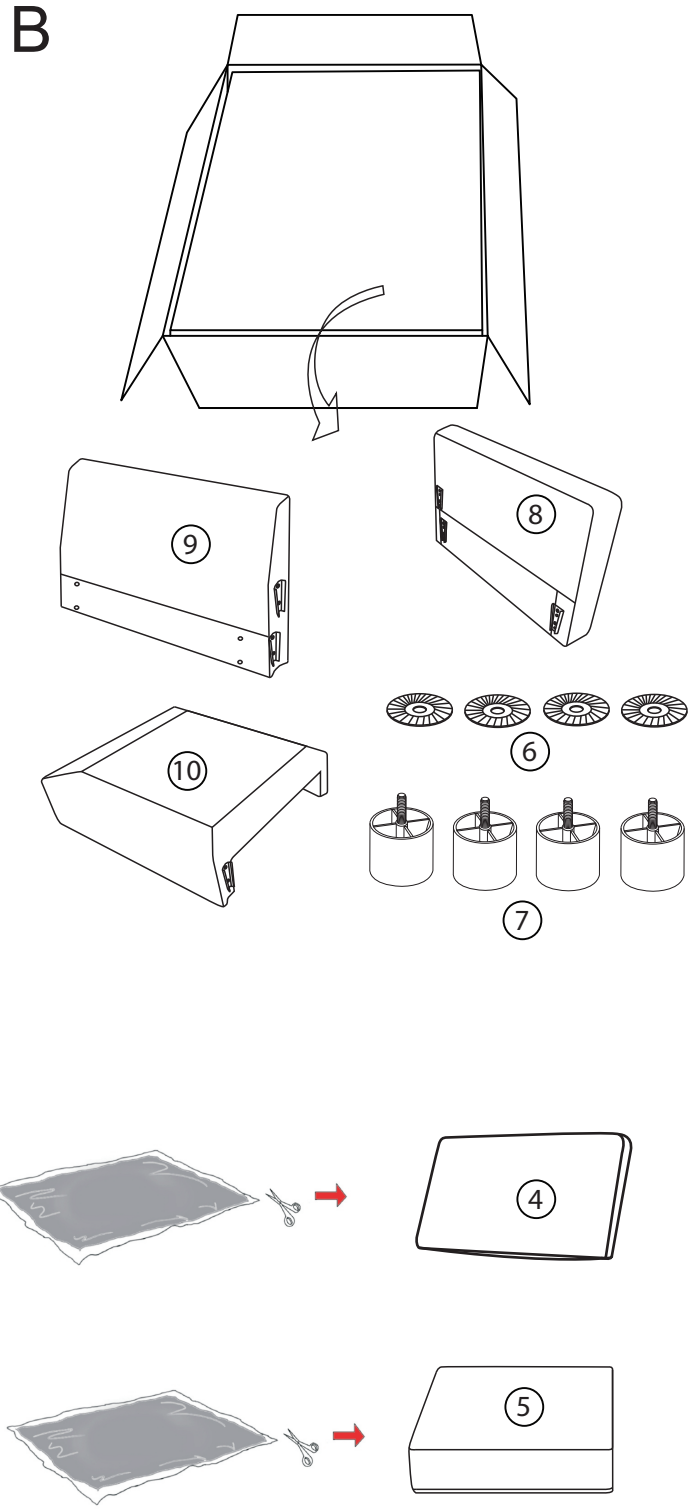
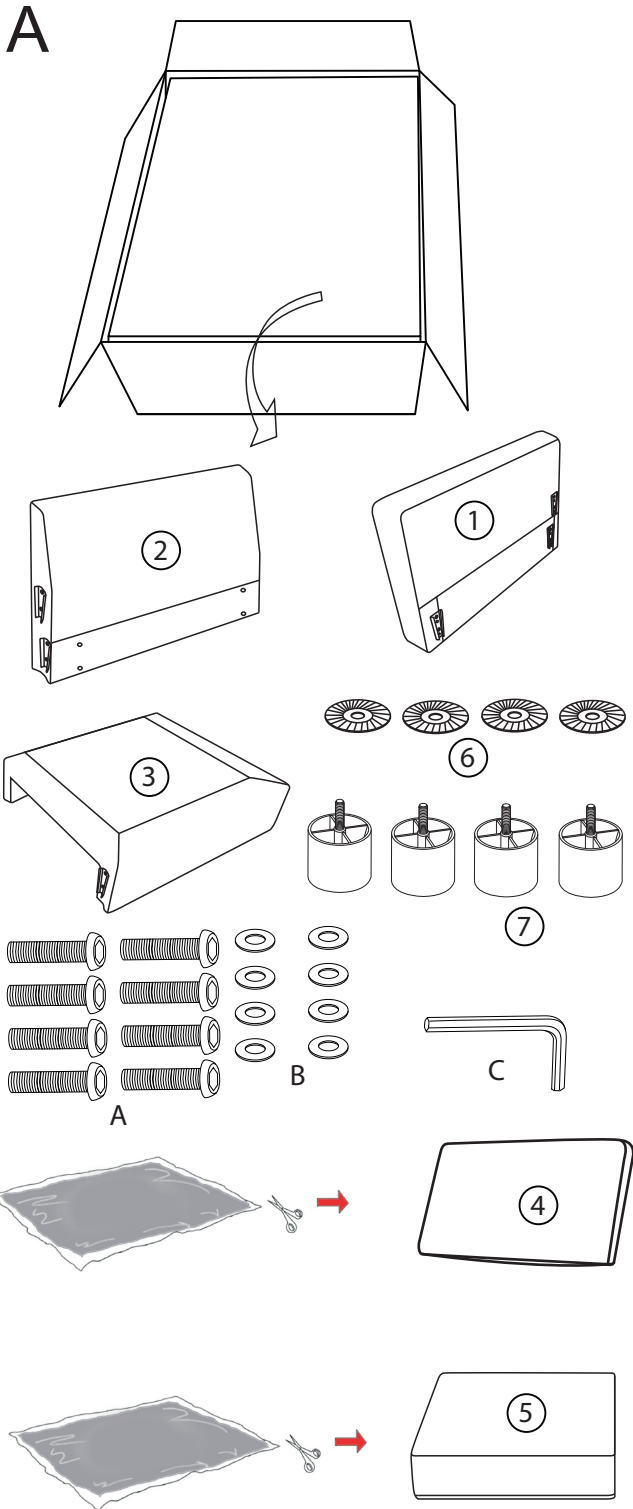

Take out all parts from the Carton A and B.

Remove the Plastic bags of back cushion and seat cushion.gently tap against thecushions,let it fluff up.

Step 1

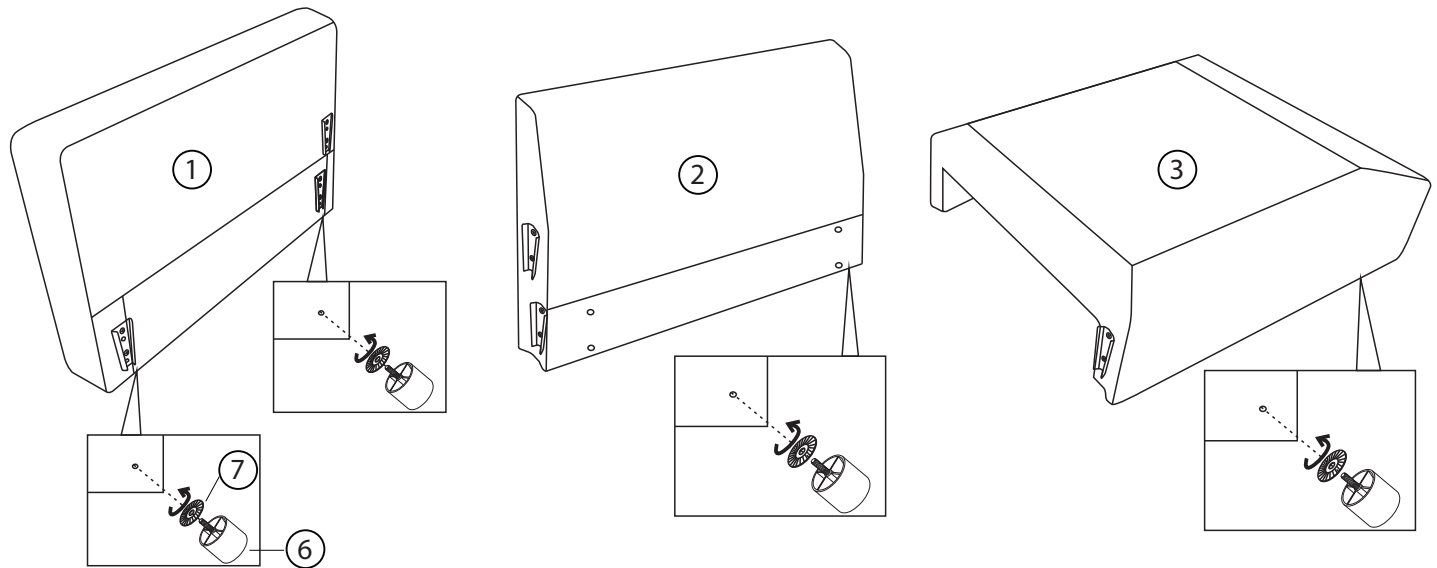

**Step 2** Install the sofa feet.

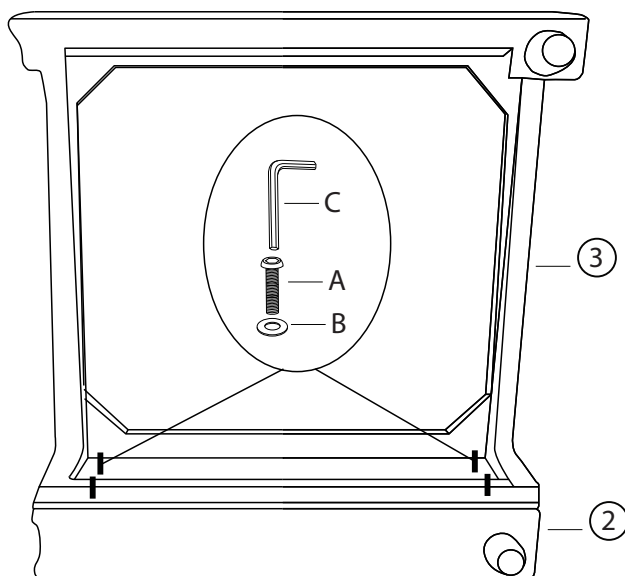

**Step 3** Connect the backrest 2 and seat frame 3 with screws as shown in the figure. 4 screws need to be installed

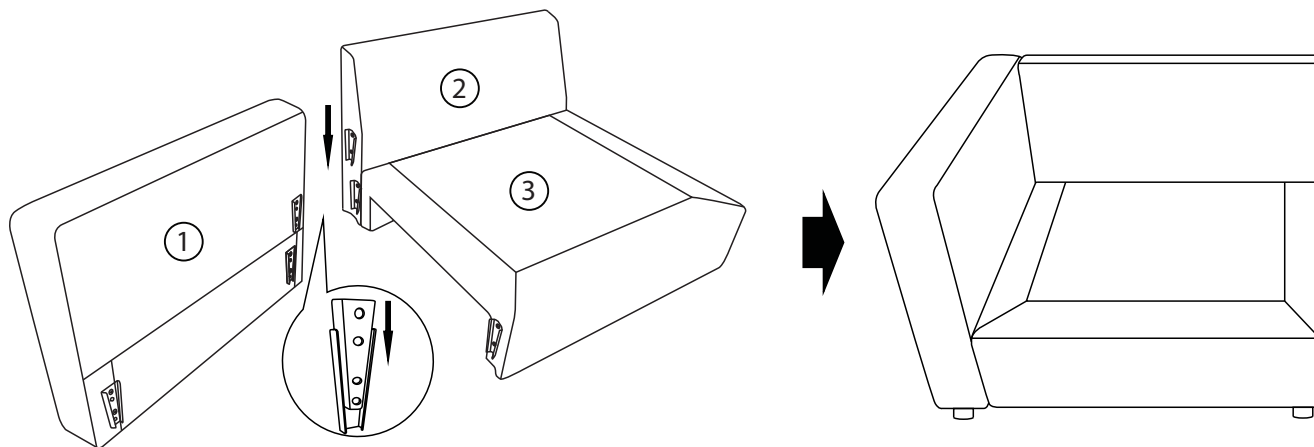

**Step 4** Connect the arm and seat frame with brackets.

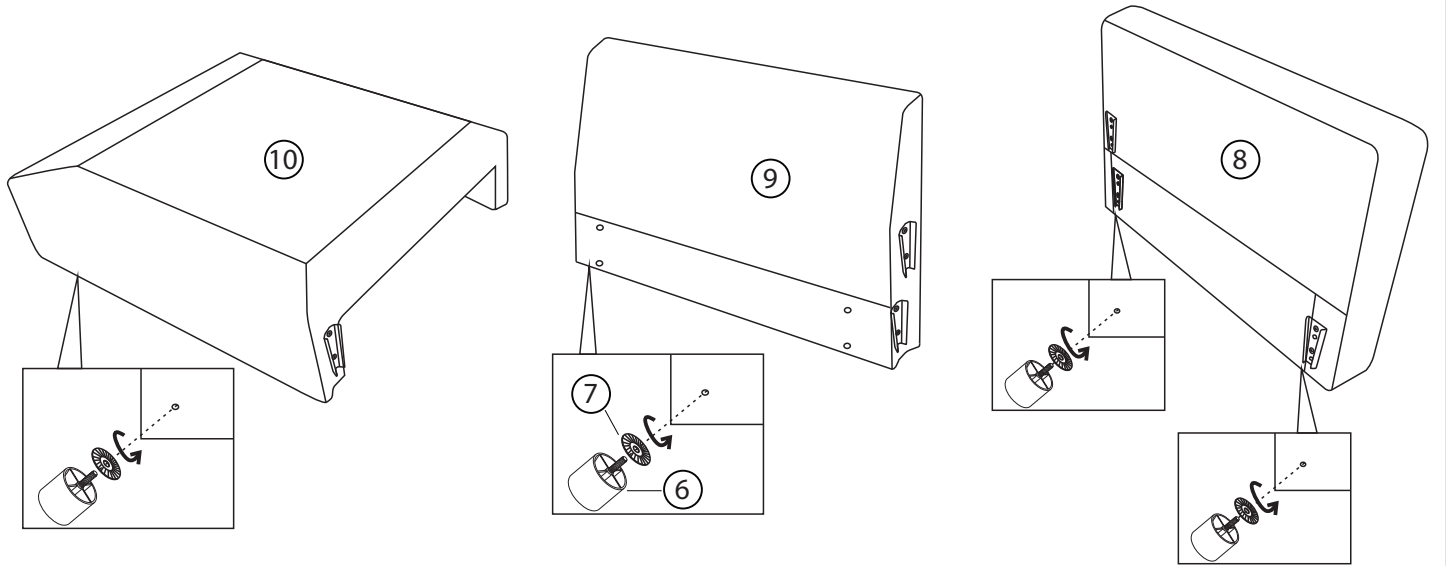

**Step 5** Install the sofa feet.

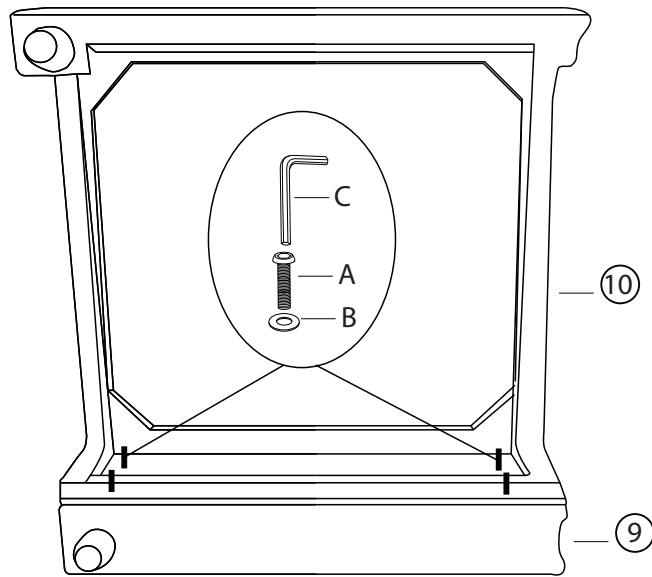

**Step 6** Connect the backrest 9 and seat frame 10 with screws as shown in the figure. 4 screws need to be installed

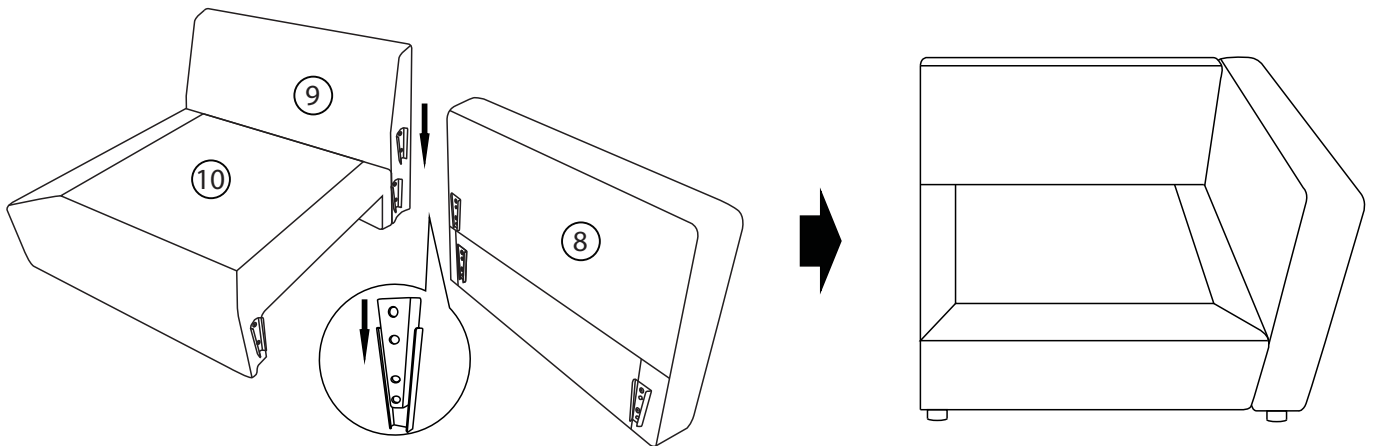

**Step 7** Connect the arm and seat frame with brackets.

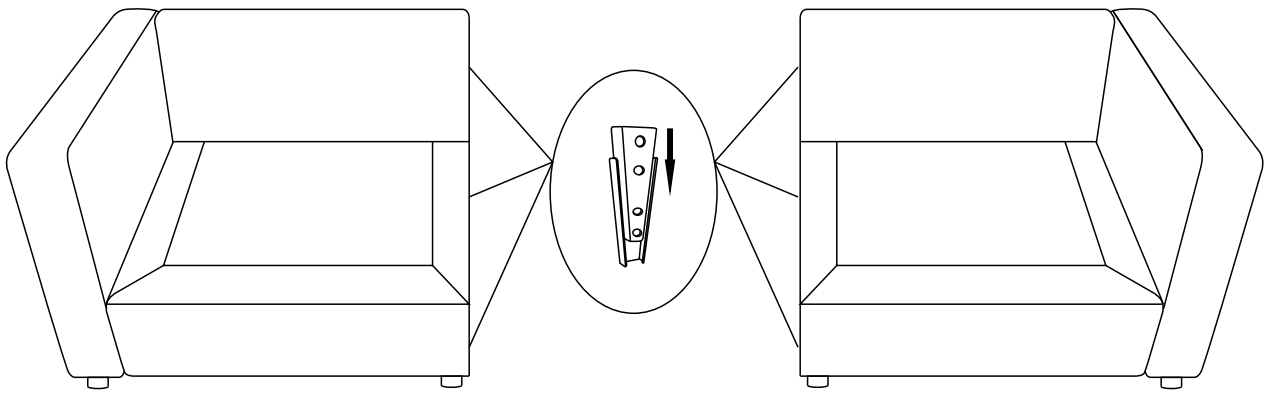

**Step 8** Connect the left sofa frame and right sofa frame with brackets.

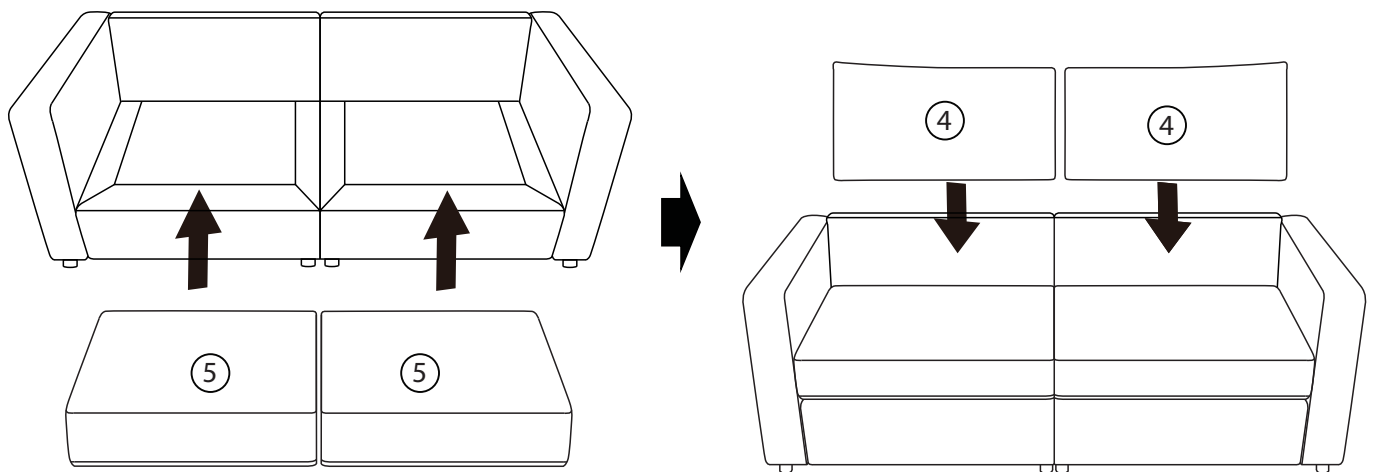

**Step 9** Place the back cushions 4 and Seat cushions to the futre.

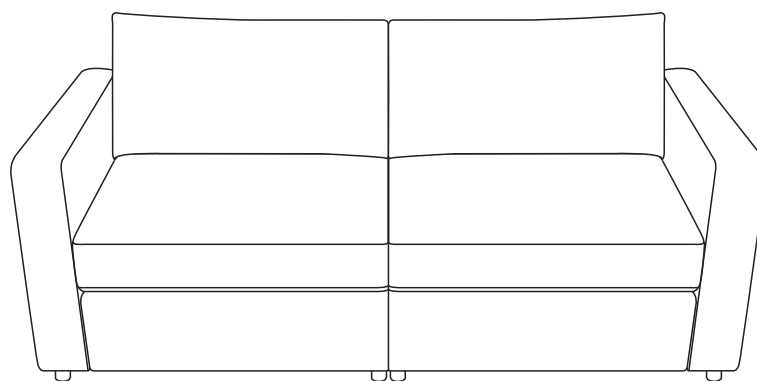

**Step 10** Assembly completed

# Frequently Asked Questions

We understand that receiving damaged or defective products can be disappointing, and we're here to assist you every step of the way. Here's how to address common concerns and initiate a damage claim:

## **1.What should I do if my shipment is damaged or products received are defective?**

We're genuinely sorry to hear about any inconvenience caused. Please reach out to us promptly, and our team will prioritize resolving the matter swiftly and effectively. To file a damage claim, follow these steps:

- A. Retain the original box in case a return is required.
- B. Take photos of the damaged box, the damaged part of the item, tracking number, and return label on the box to help us process a replacement or refund.

## **2.Can I return the product if I'm not satisfied?**

While we uphold stringent quality standards and collaborate with experienced manufacturers, we acknowledge that dissatisfaction may arise. If you're still unsatisfied, you can initiate a return within 30 days of receiving the product. Simply message us with your reasons for return, and we'll facilitate the process.