

ASSEMBLY INSTRUCTION

# User's Manual

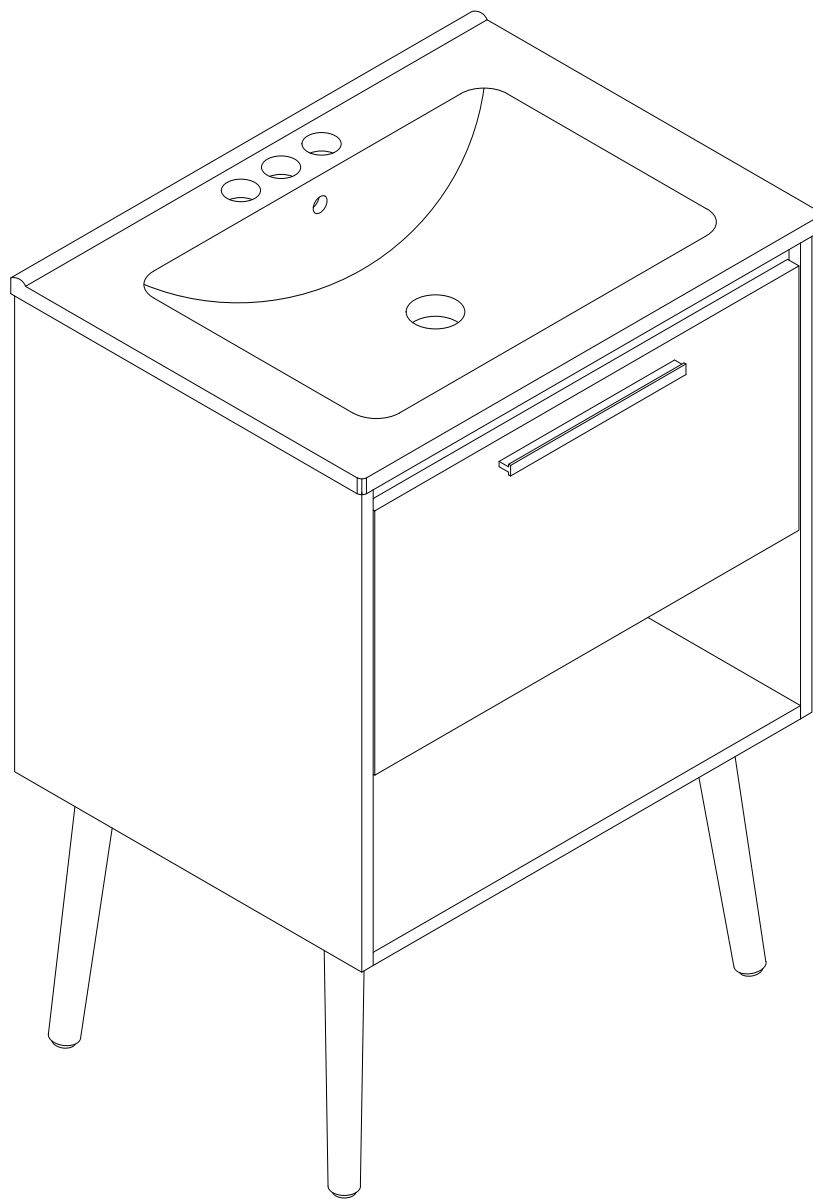





# Before Installation

Important-Please read these instructions fully before starting assembly

Thank you for purchasing this quality product. Be sure to check all packing materials carefully for small parts, which may have come loose inside the carton during shipment. Identify and count all items according to the PARTS LIST and/or HARDWARE LIST shown below. Check you have all the components and tools listed on the following pages.

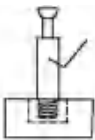
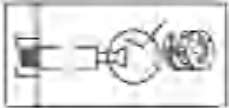
- We recommend that you assemble this product with the assistance of another person; this will make the assembly easier, and will help eliminate damage to the product or injury to persons during assembly.
- Please do not over tighten screws or bolts until the assembly is completed.
- Keep children and animal away from the work area, small parts could choke if swallowed. Please put all parts on a non-abrasive floor before assembly, and follow the assembly steps to assemble your newly purchased product correctly and efficiently.

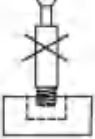
## Cam Lock Assembly Instructions

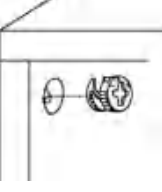
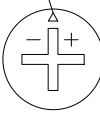
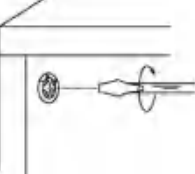
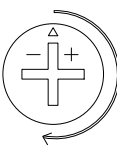
		Diagram A Insert Cam Bolt into hole as shown in diagram A.
		Diagram B Make sure not to insert the Cam Bolt: Too deep as shown in figure B as this will cause the Cam Lock to be misaligned and unable to interlock properly.
		Diagram C Also avoid inserting the Cam Bolt too close to the surface of the hole as shown in figure C, as this will cause the Cam Lock to be too loose, and not interlock properly.
		Connect the panels together.
		Insert the Cam Lock so the side opening fits over the head of the Cam Bolt.
		To tighten the Cam Lock, turn it clockwise on half a turn with a flat screwdriver. *Do not use an automatic screwdriver as it may bend or break if too much power is imposed.

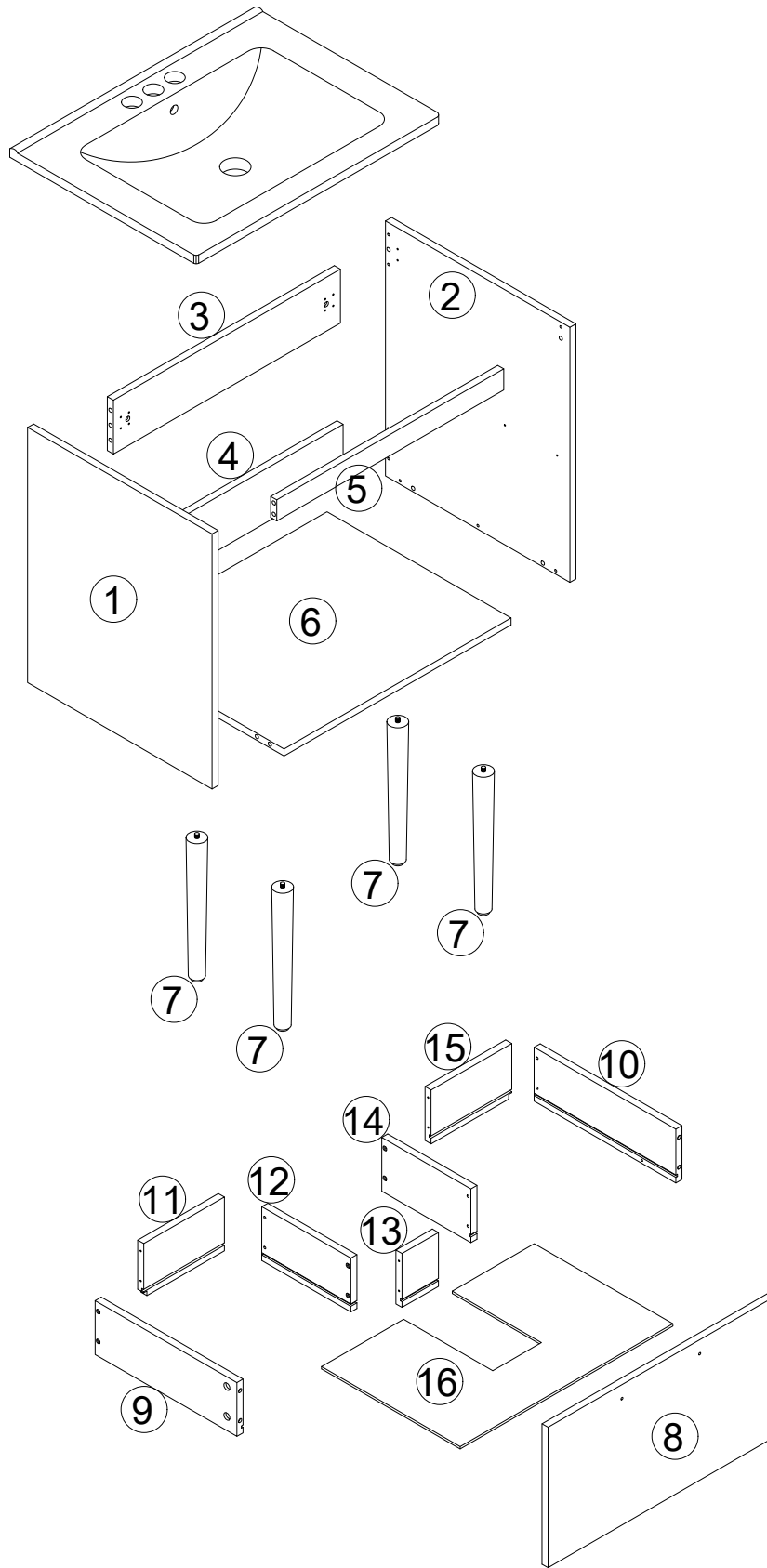

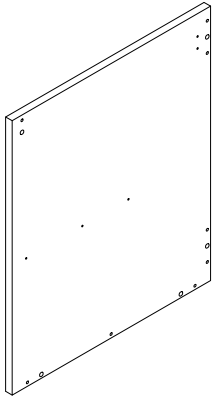

① x 1

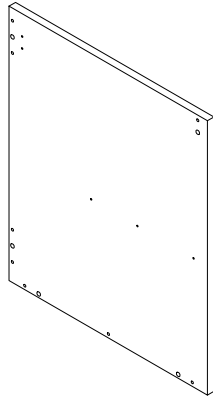

② x 1

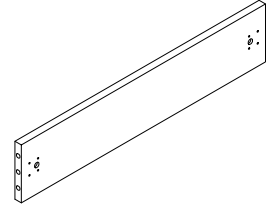

③ x 1

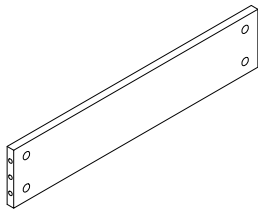

④ x 1

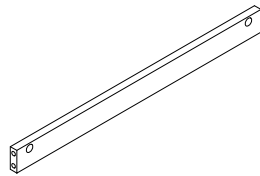

⑤ x 1

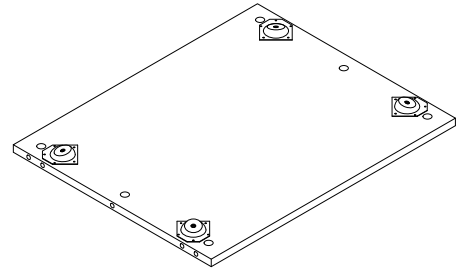

⑥ x 1



⑦ x 4

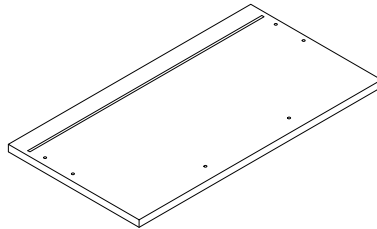

⑧ x 1

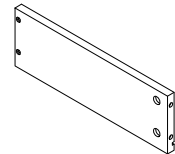

⑨ x 1

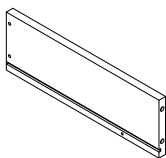

⑩ x 1

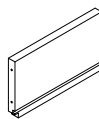



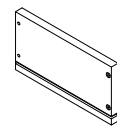



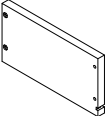
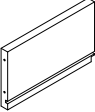
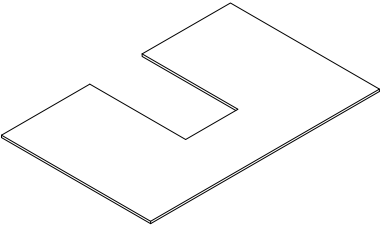
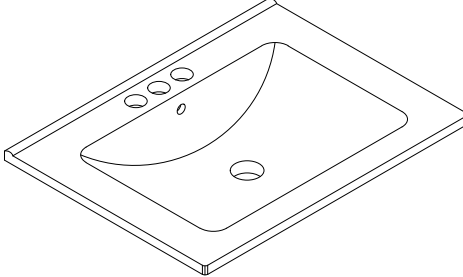

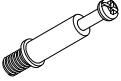

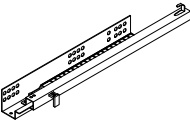
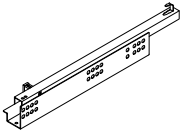
⑪ x 1

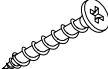

⑫ x 1

		
⑬ x 1	⑭ x 1	⑮ x 1
		
⑯ x 1		

					
Φ6x35mm A x 20+2	Φ15x12mm B x 20+2	Φ8x30mm C x 10+1	D x 1	E x 1	F x 2
					
M4x14mm G x 12+1	M4x14mm H x 6	M4x18mm I x 2	M4x35mm J x 12+1	M6x60mm K x 2	L x 1
					
Φ8x40mm M x 2	N x 4				

# Step 1

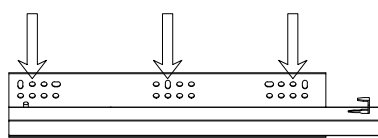
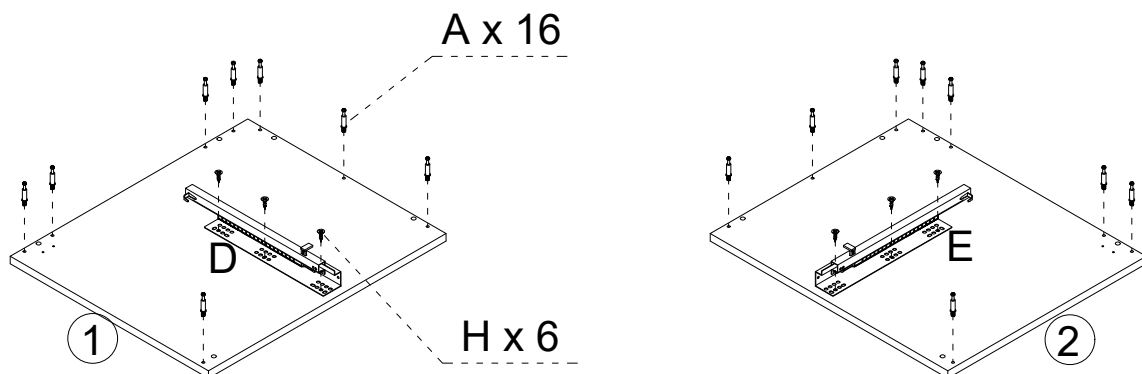

D

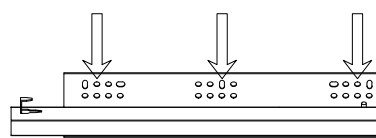

E

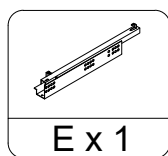
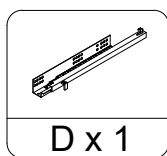
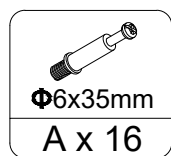

# Step 2

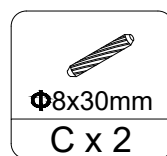
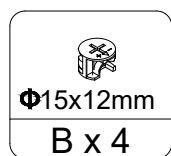
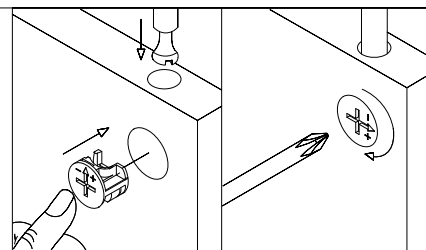
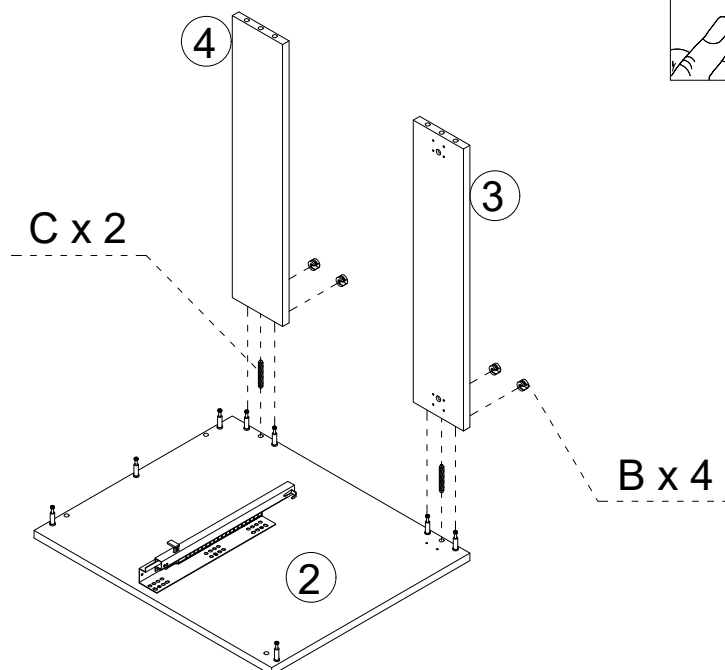

### Step 3

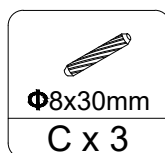
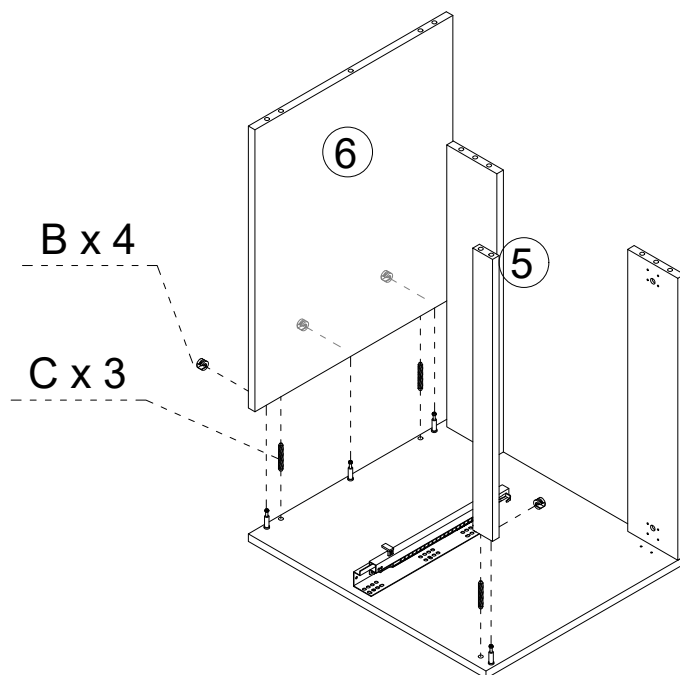
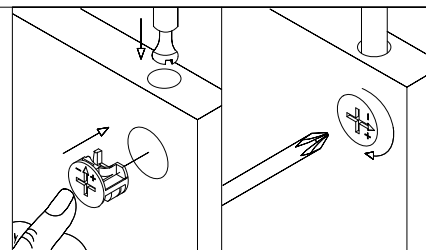

### Step 4

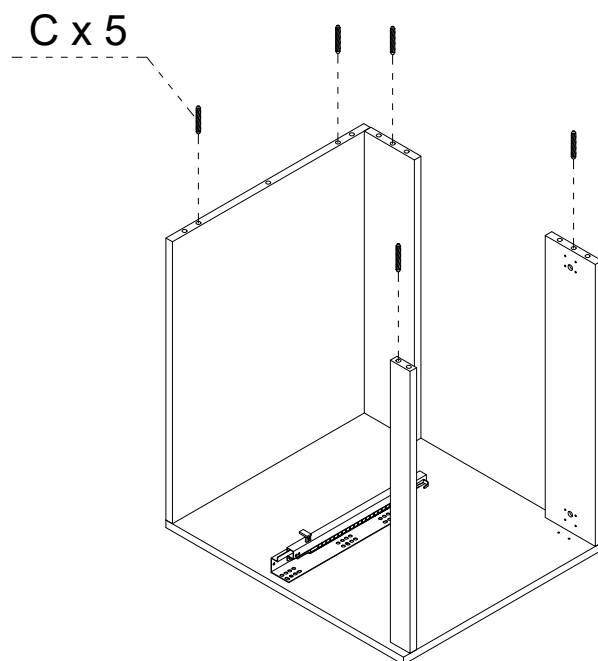

## Step 5

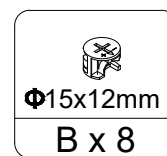
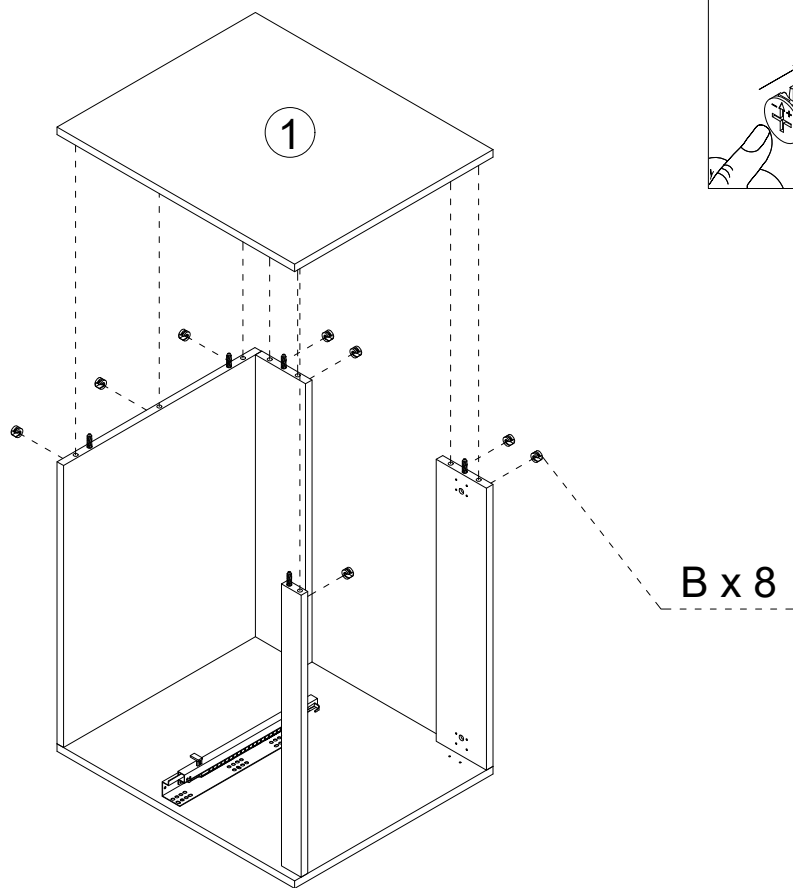

## Step 6

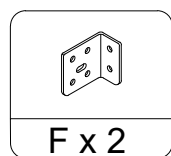
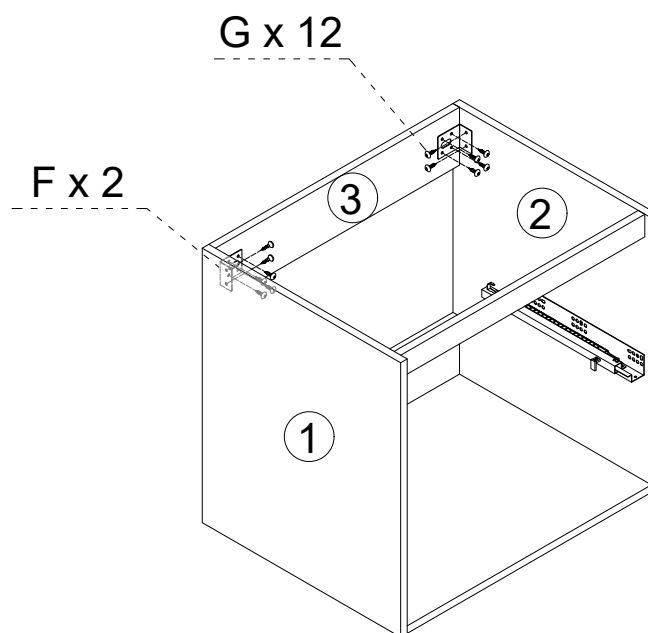



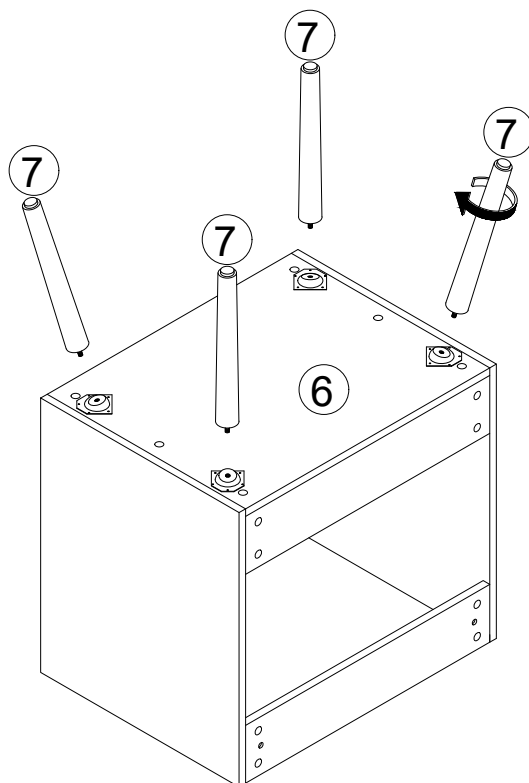

## Step 7

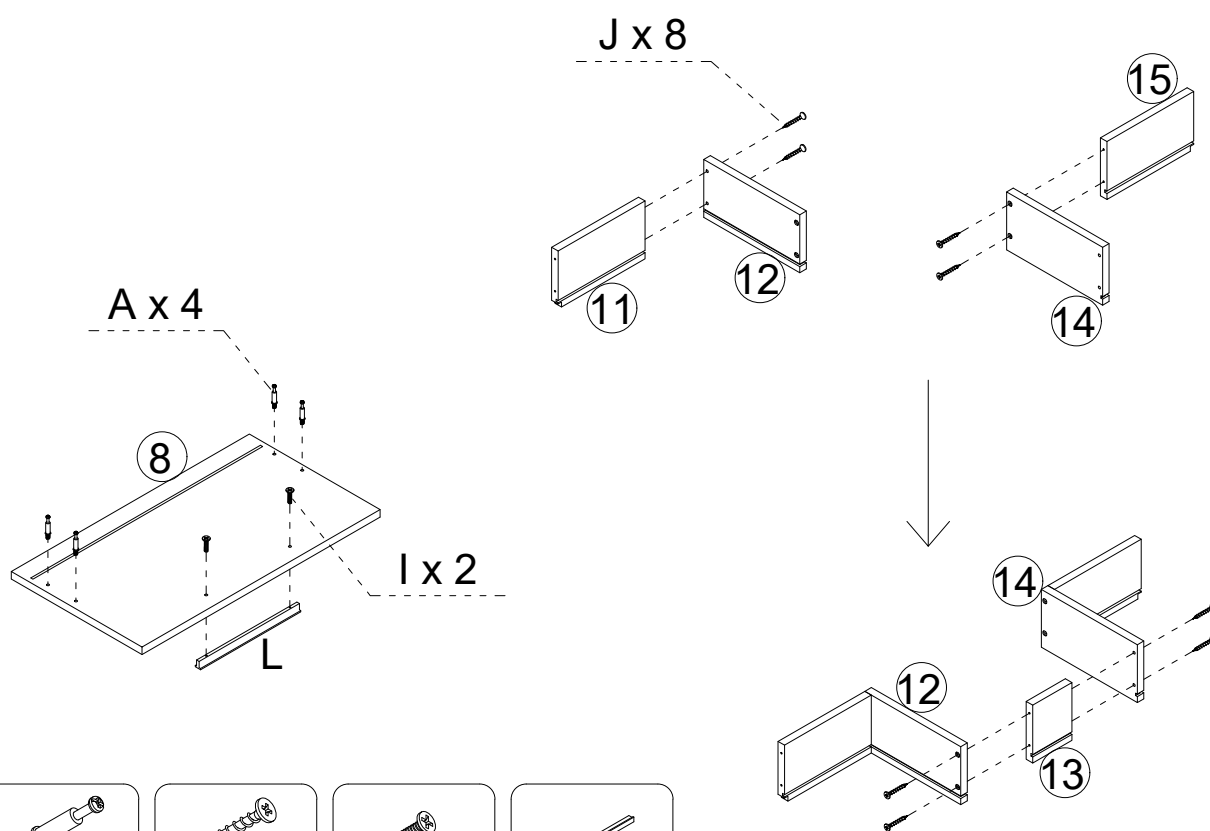

## Step 8



 Φ6x35mm A x 4	 M4x35mm J x 8	 M4x18mm I x 2	 L x 1
---	---	---	--

## Step 9

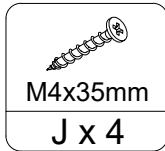
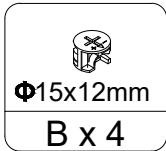
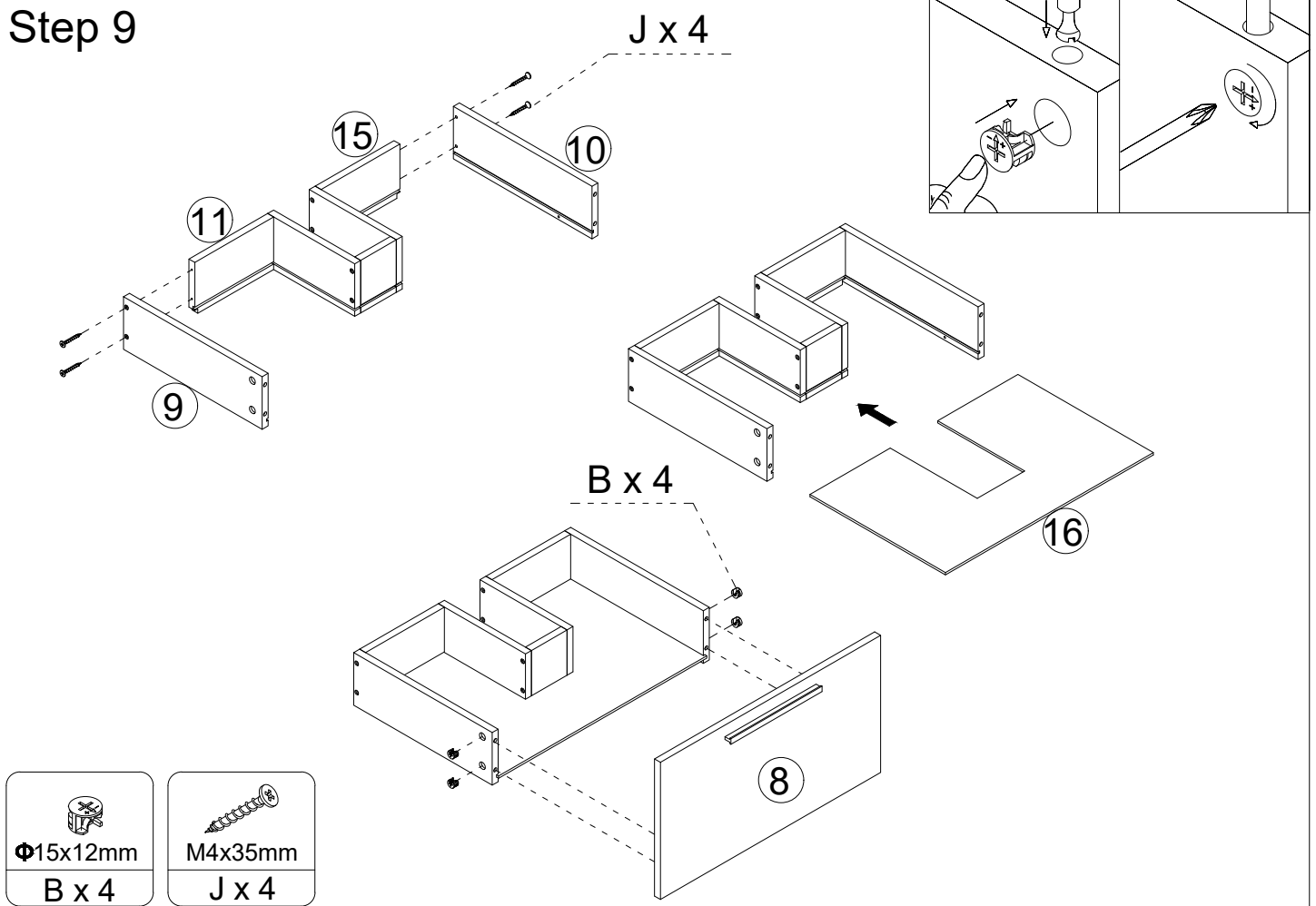

## Step 10

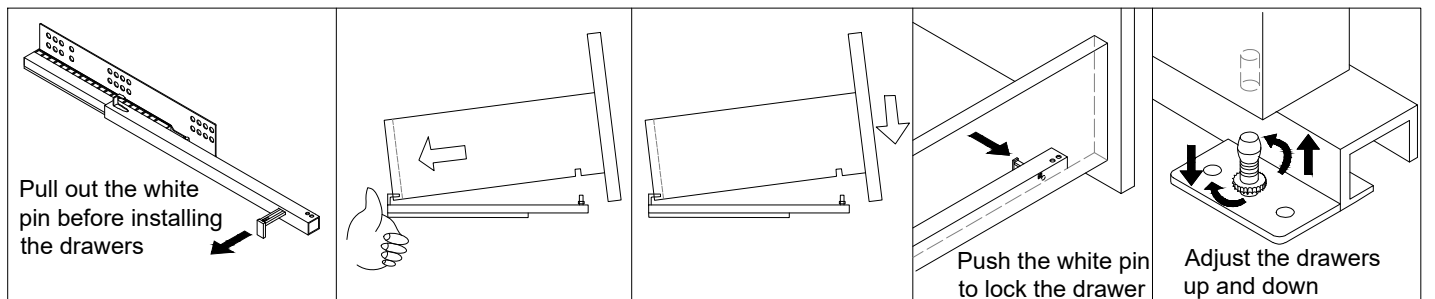
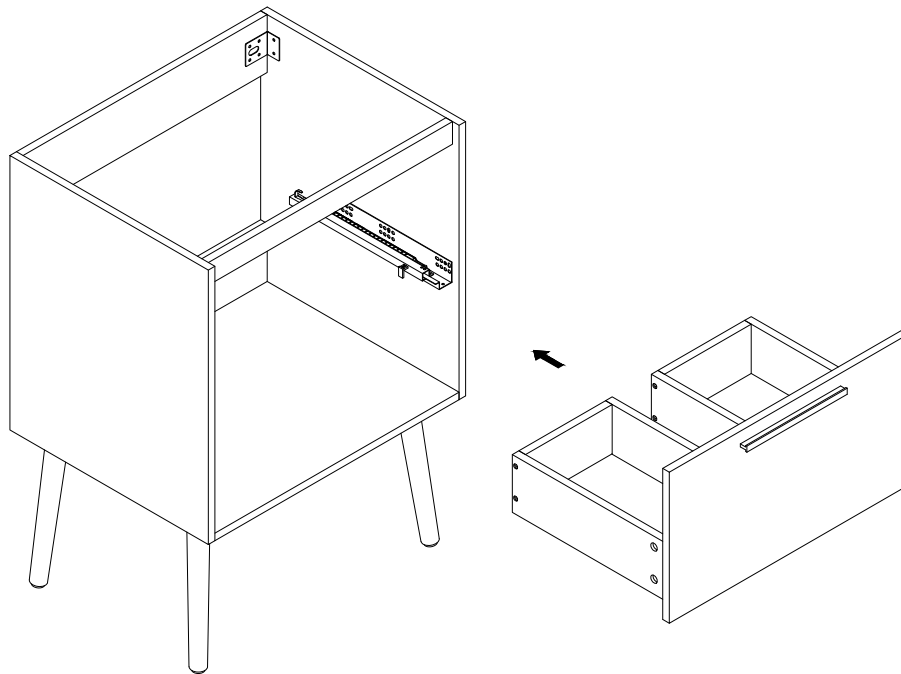

# Step 11

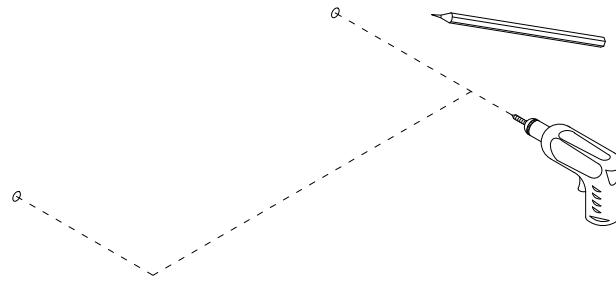
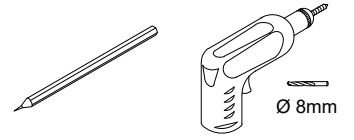

# Step 12

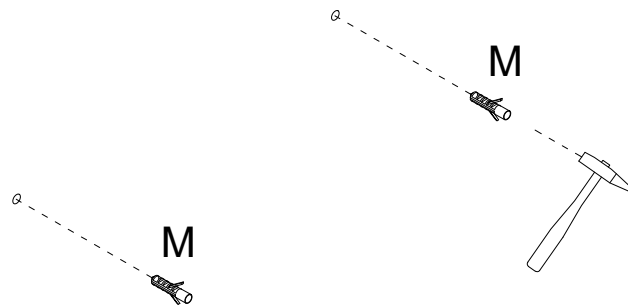

## Step 13

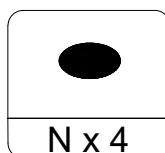
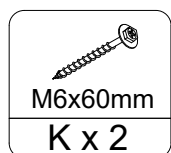
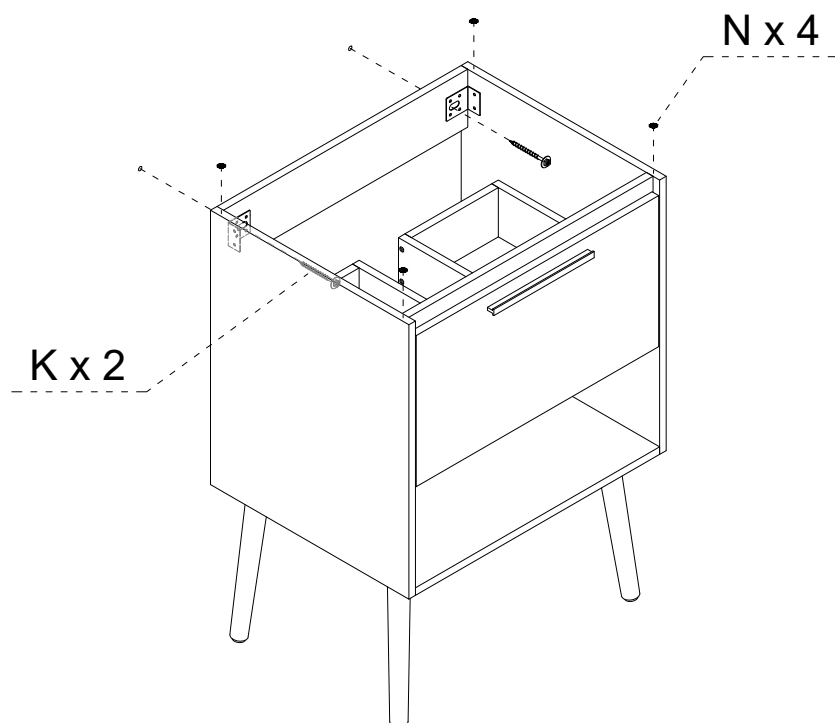

## Step 14

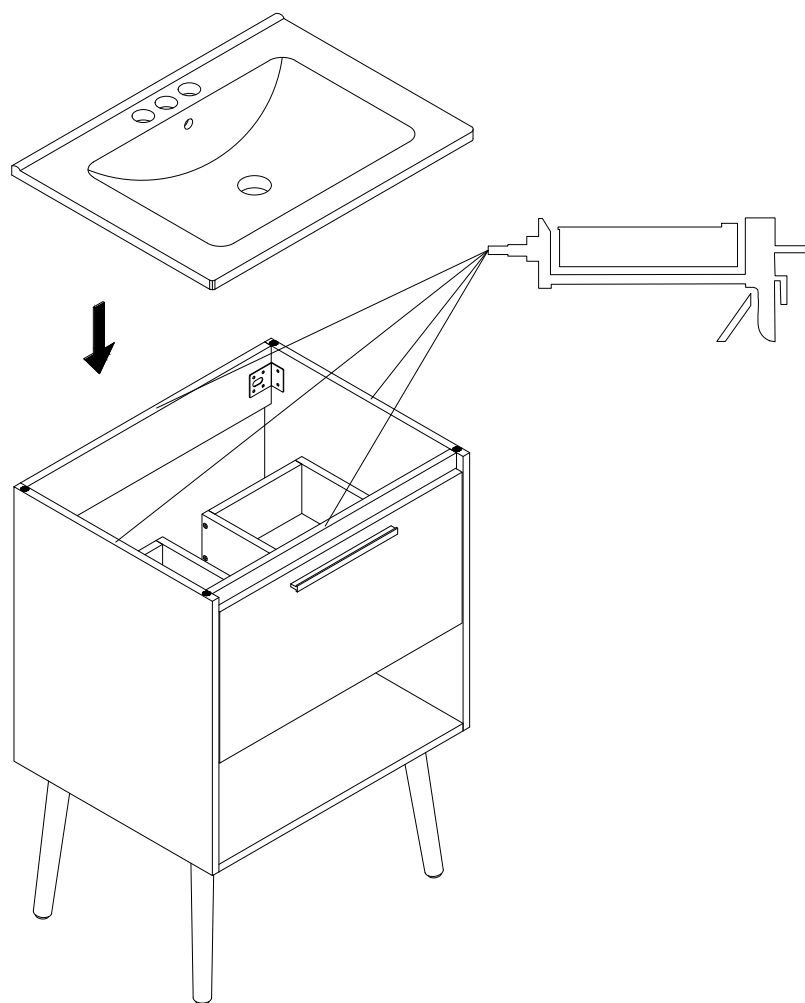

## **IMPORTANT-READ CAREFULLY-RETAIN FOR FUTURE REFERENCE**

### **WARNING:**

- Children must stay away from the assembly zone, preventing children from potential asphyxia because of plastic bag and foam breathing in nose;
- For your safety, please do not tread or climb product.
- The loading weight shall be within the range that vendor claims. The product is designed for adults use, domestic use and indoor use only.
- The product shall not combine with other product for use.
- If the product with seat height adjustments with energy accumulators that only trained personnel may replace or repair seat height adjustment components with energy accumulators
- Check regularly that all assembly fastenings are properly tightened, do not use the product if any structural part is broken or missing
- Incorrect installation and incorrect use can cause accidents. Please completely follow the guidance of assembly instruction.

### **Security instructions:**

- Before assembling check whether all parts listed in the parts list have been delivered. Do not start assembling if parts are missing or damaged.
- A failure to assemble this product correctly could cause damage or result in serious injury! Before assembling make sure that you have enough space for the procedure. Assemble on a flat surface.
- Keep the assembly instructions available at all times and follow each of the individual steps exactly.
- During assembly, be careful with all the parts of the assembly (do not walk on them or distort them) and beware of shearing and trapping risks. Keep children and pets away while setting up the furniture.