



Assembly Instructions

Caution : You must read this before you proceed

Care & Maintenance

- ⊘  ● Not for commercial use. For residential use only.
- ✓  ● Furniture may scratch floors. We recommend using furniture pads to protect your floors.
- ⊘  ● Do not put hot items directly on furniture surface.
- ⊘  ● Do not clean furniture with harsh cleansers or polish.
- ⊘  ● Do not place furniture under direct sunlight.
- ⊘  ● Do not place furniture near heating or cooling vents.
- ⊘  ● Do not write on furniture without a padded barrier to protect the surface.
- ⊘  ● Do not place furniture outside . For indoor use only.
- ⊘  ● Stains may be removed with mild soap solution and damp cloth.
- ⊘  ● Children should not climb or jump on the furniture.
- ✓  ● Dust and pick-up spills using a clean, non-colored, lint-free cloth.

Please look in chair seat for hardware packs and legs.
Sets often ship in multiple boxes and may arrive a day or two apart.

Club Chair



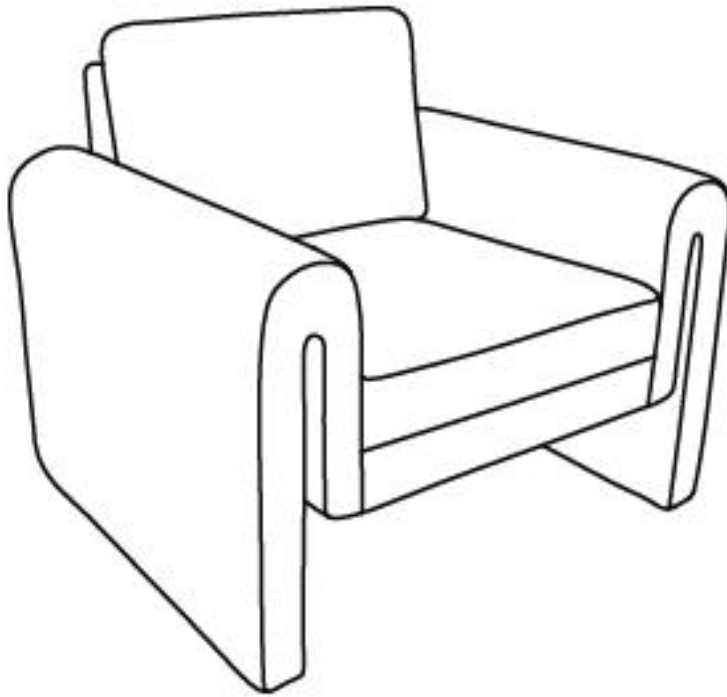

SKU:N765P248341

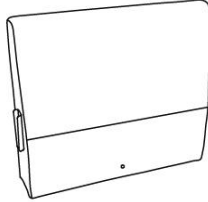
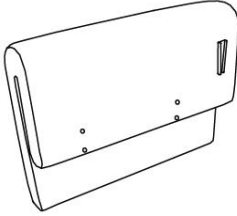
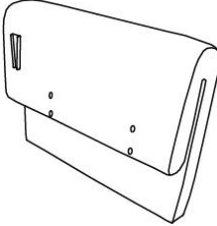
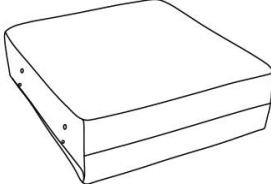
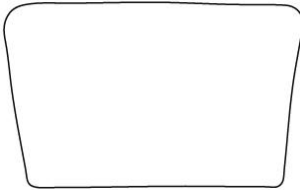

Parts List

Label	Picture	Description	QTY
A		Backrest	1
B		Left Armrest	1
C		Right Armrest	1
D		Seat	1
E		Pillow	1

Hardwares

Label	Picture	Description	QTY
①		Bolt (M8*60MM)	10
②		Washer(M8*22MM)	10
③		Spring Washer(M8)	10
④		Allen Wrench	1

Assembly Preparation

Before
Beginning
Assembly:

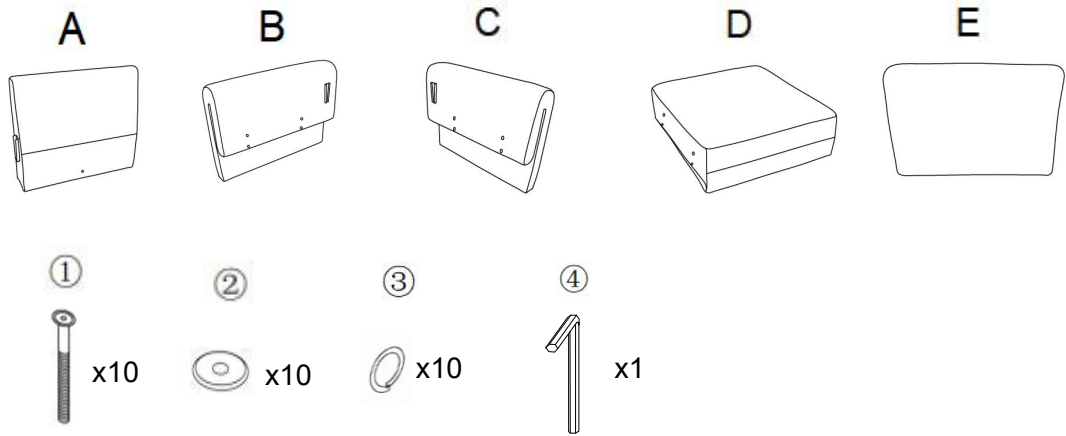

- Read instructions, cover to cover-



- Have 2 adults on hand for assembly-



- Do not assemble on flooring or carpet-



- Assemble on a clean non-marring surface (packing foam)-



- Save all packaging until finished-

Assembly Steps

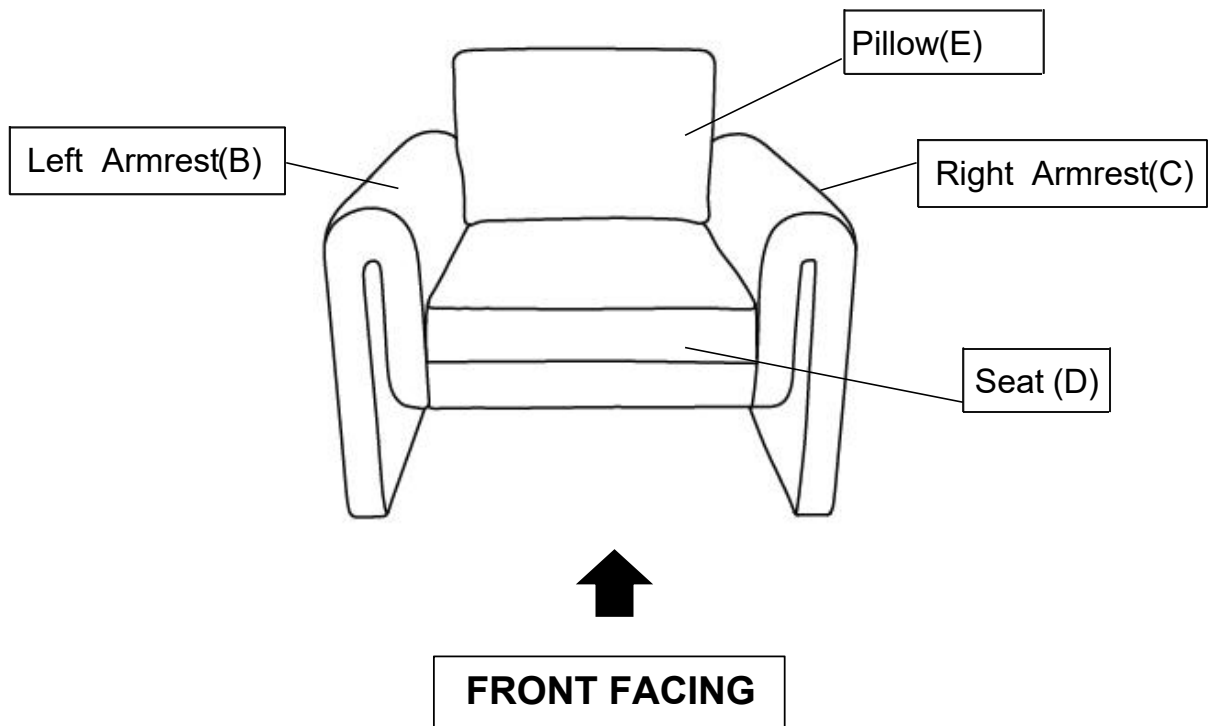

This Chair has multiple parts and may require up to 30 minutes to assemble.

To give you an overview of the Chair, the above picture is to help you put the various parts into perspective.

Please read through the instructions below to familiarise yourself with the parts and steps before assembly.

Note: It is recommended that you have an adult partner to assist during the entire assembly process.

Step 1

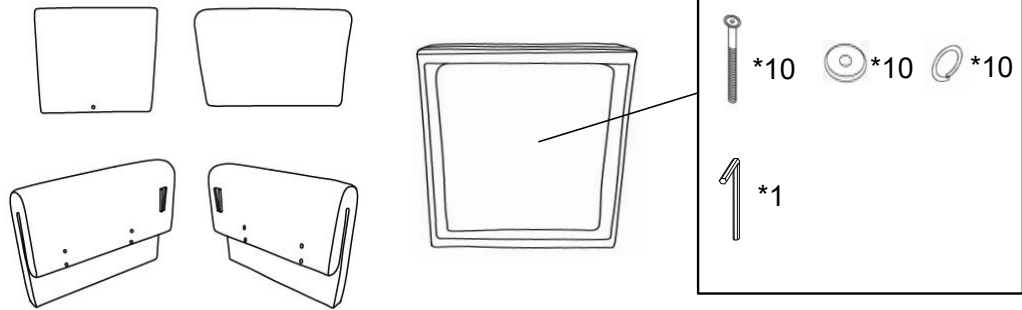

Position the Backrest(A), Left Armrest(B), Right Armrest(C), Seat (D) and Pillow(E) on a clean, non-marring surface, as shown.

Do not place on surface that can scratch or damage the upholstery.

Take out the Hardwares from the bottom of Seat(D).

Step 2

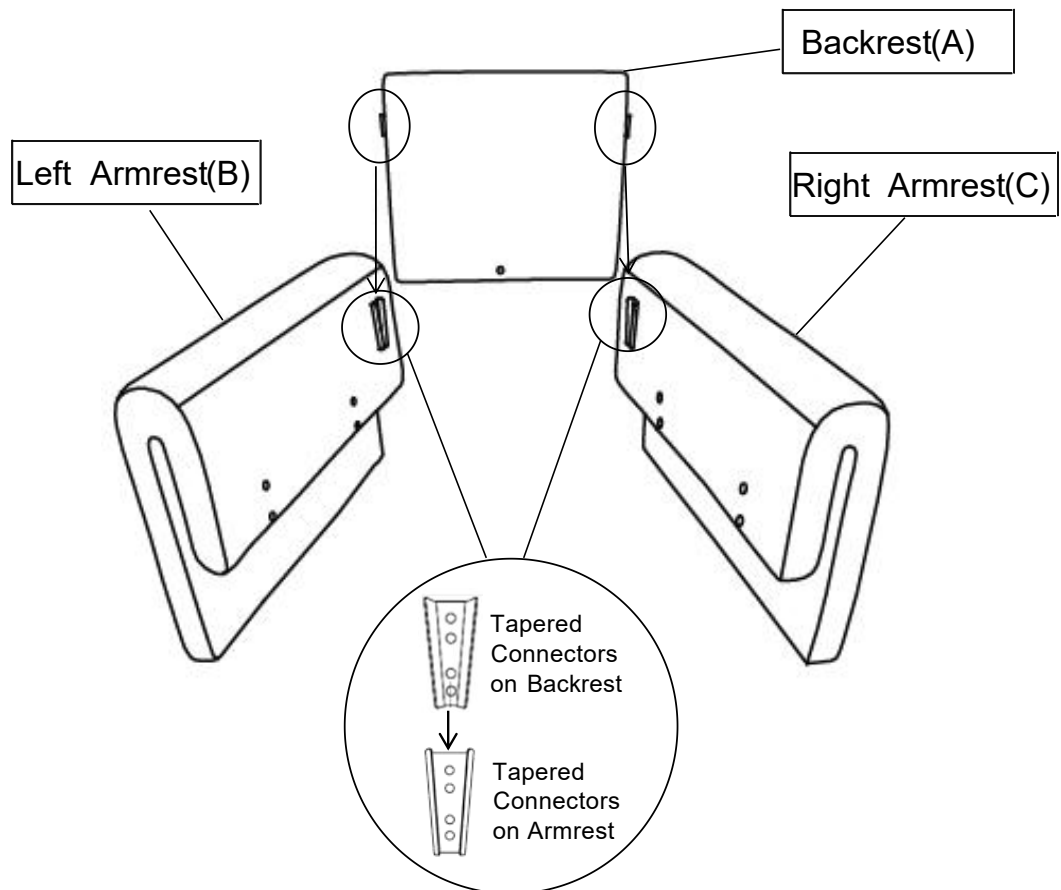

With the assistance from your adult partner:

1.1) Lift the Backrest(A) up, make sure the Backrest(A) is vertical and aligned to the Armrests. Align the Tapered Connectors on the Backrest(A) with those on the Armrest(B&C).

Your adult partner may need to push the Armrests in towards the Backrest(A) to allow for better alignment.

Slip and Slide the Backrest, in a gradual and balanced manner into the Tapered Connectors.

1.2) Push the Backrest(A) downwards until it is fully slotted and locked into position.

Note: Make sure the Tapered Connectors on the Backrest(A) lock into the Tapered Connectors on Armrest(B&C) .

Step 3

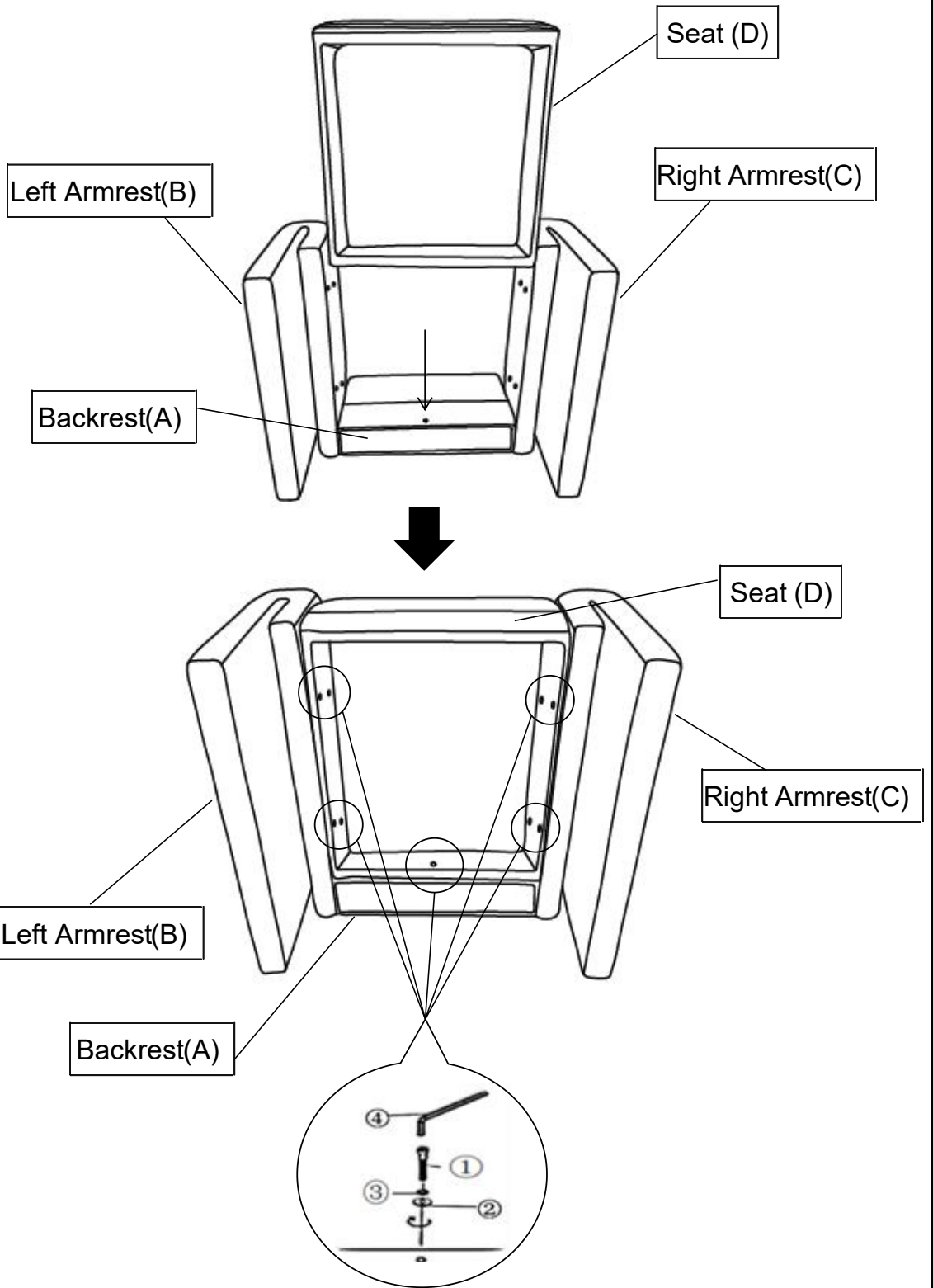

Turn the assembled Backrest as picture shown.

Attach Seat(D) to the semi-assembled product(STEP2) using Bolts(①), Washers(②) and Spring Washer(③) with the Allen Wrench (④) as pictured above.

Tighten the Bolts fully in a sequential manner.

DO NOT fully tighten a Bolt in one go and then move on to the next.

Rather, In a sequential manner, gradually tighten each Bolt until all Bolts are evenly secured.

Step 4

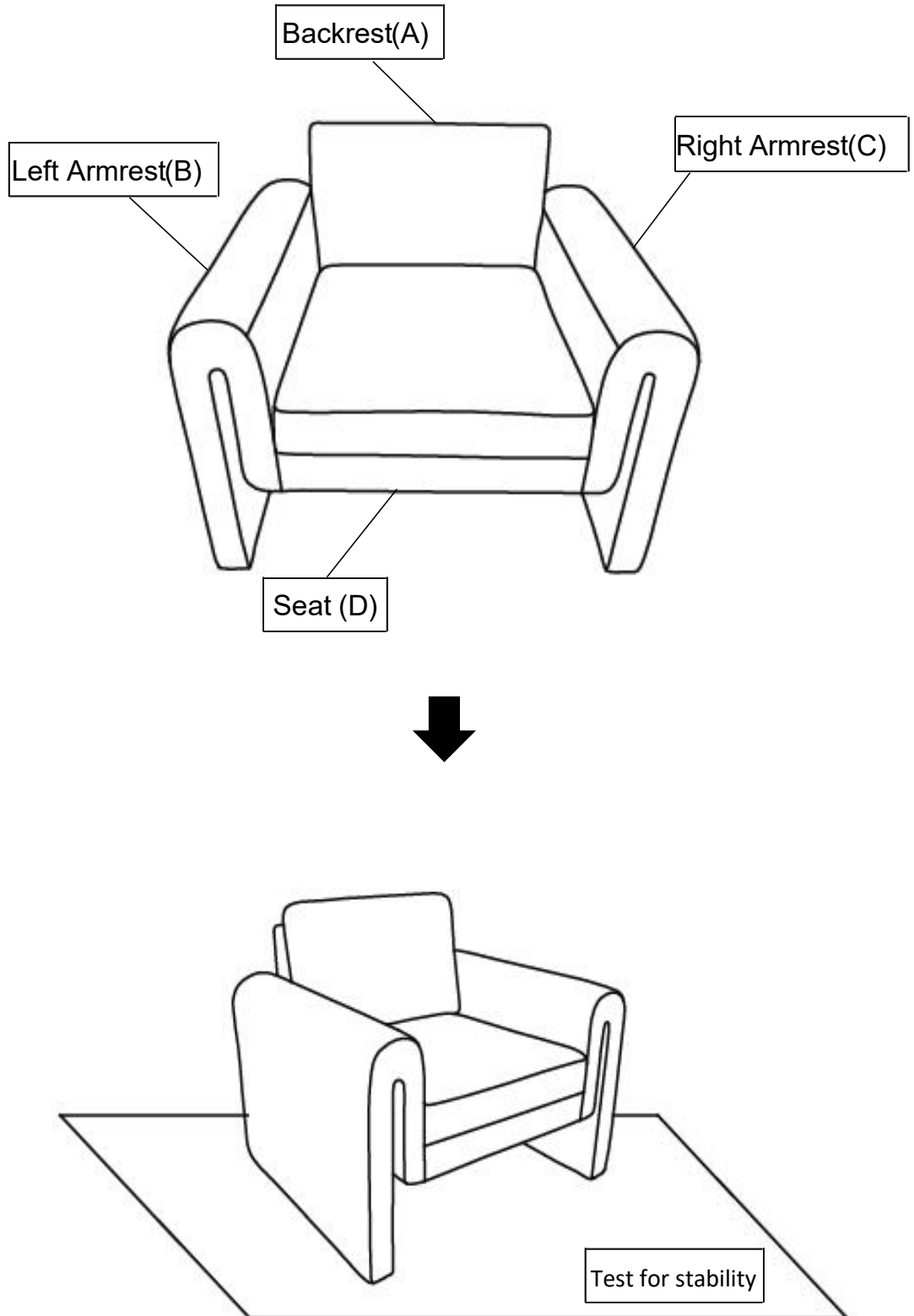

Place the Pillow(E) onto the Chair.
Your Club Chair is ready for use.
This Club Chair can only be used on a flat, level surface.