



ASSEMBLY INSTRUCTIONS COASTER FINE FURNITURE



Fine Furniture for every stage of life

121231(B1&B2) Dining Table

REVISION 0 : 05/30/2018
REVISION 1 : 09/04/2018
REVISION 2 : 07/01/2020

ITEM:121231(B1&B2)



ASSEMBLY INSTRUCTIONS

ASSEMBLY TIPS:

1. Remove hardware from box and sort by size.
2. Please check to see that all hardware and parts are present prior to start of assembly.
3. Please follow attached instructions in the same sequence as numbered to assure fast & easy assembly.

WARNING!



1. Don't attempt to repair or modify parts that are broken or defective. Please contact the store immediately.
2. This product is for home use only and not intended for commercial establishments.







ASSEMBLY TIME

10 MINUTES

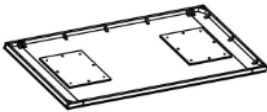
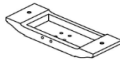
PARTS IDENTIFICATION

B1 (BOX 1)







A	TOP		1PC	D	BASE		2PCS
B	LEAF		2PCS	E	CROSS BAR		1PC
C	MOUNTING PLATE		2PCS				

B2 (BOX 2)

F	PEDESTAL COLUMN		2PCS
---	-----------------	-------------------------------------------------------------------------------------	------

HARDWARE IDENTIFICATION

Z-B1(BOX 1) - HARDWARE PACK IS LOCATED IN 121231(B1)

1	LONG BOLT (5/16" x 45mm - BLK)		12PCS	5	FLAT WASHER (5/16" x 22D x 2mm - BLK)		28PCS
2	SHORT BOLT (5/16" x 38mm - BLK)		8PCS	6	ALLEN WRENCH (4mm - BLK)		1PC
3	HEX NUT (5/16" x 12mm - BLK)		8PCS	7	WRENCH (12mm - BLK)		1PC
4	LOCK WASHER (5/16" x 12D x 1.1mm - BLK)		28PCS				

ITEM: **121231(B1&B2)**



ASSEMBLY INSTRUCTIONS
STEP 1

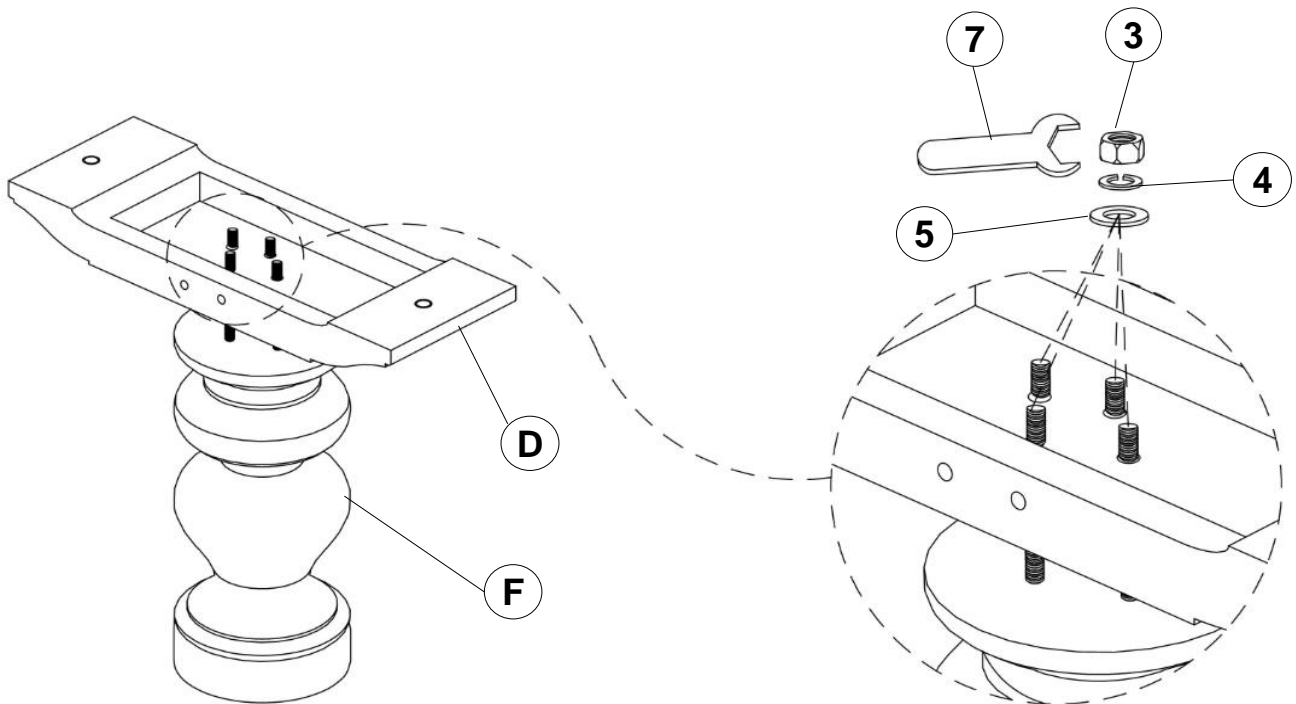

STEP 2

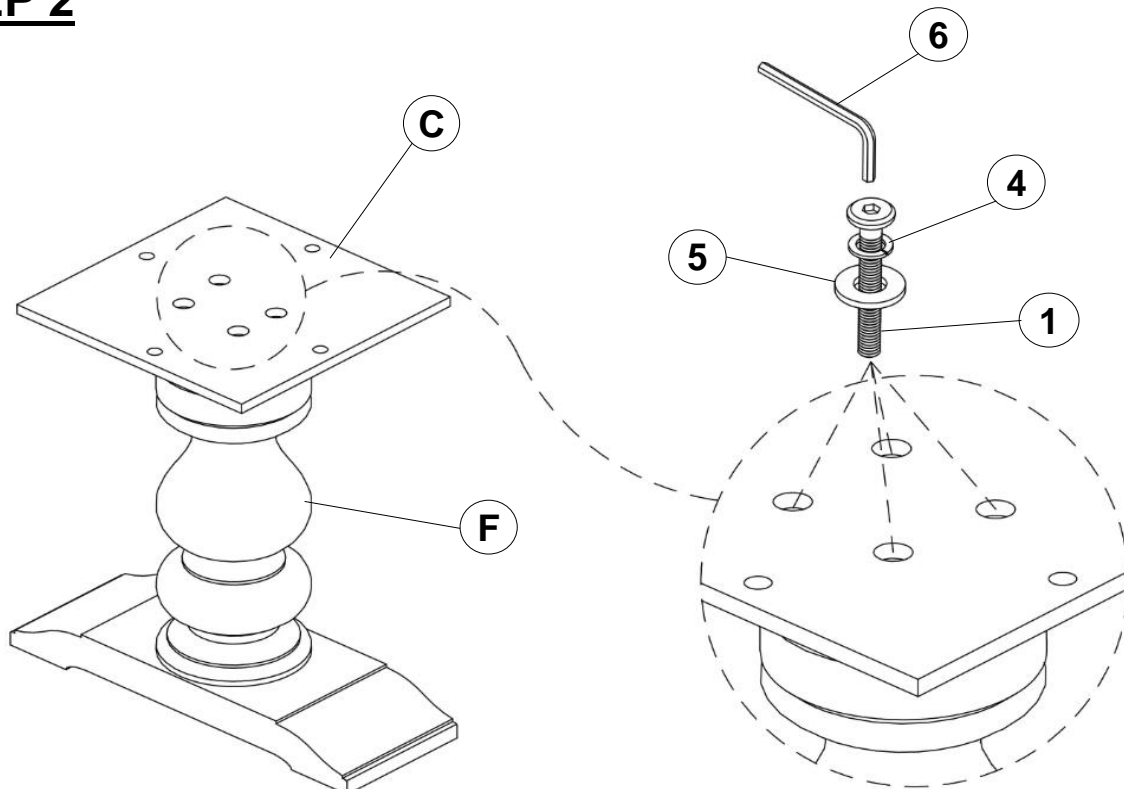

ITEM: **121231(B1&B2)**



ASSEMBLY INSTRUCTIONS
STEP 3

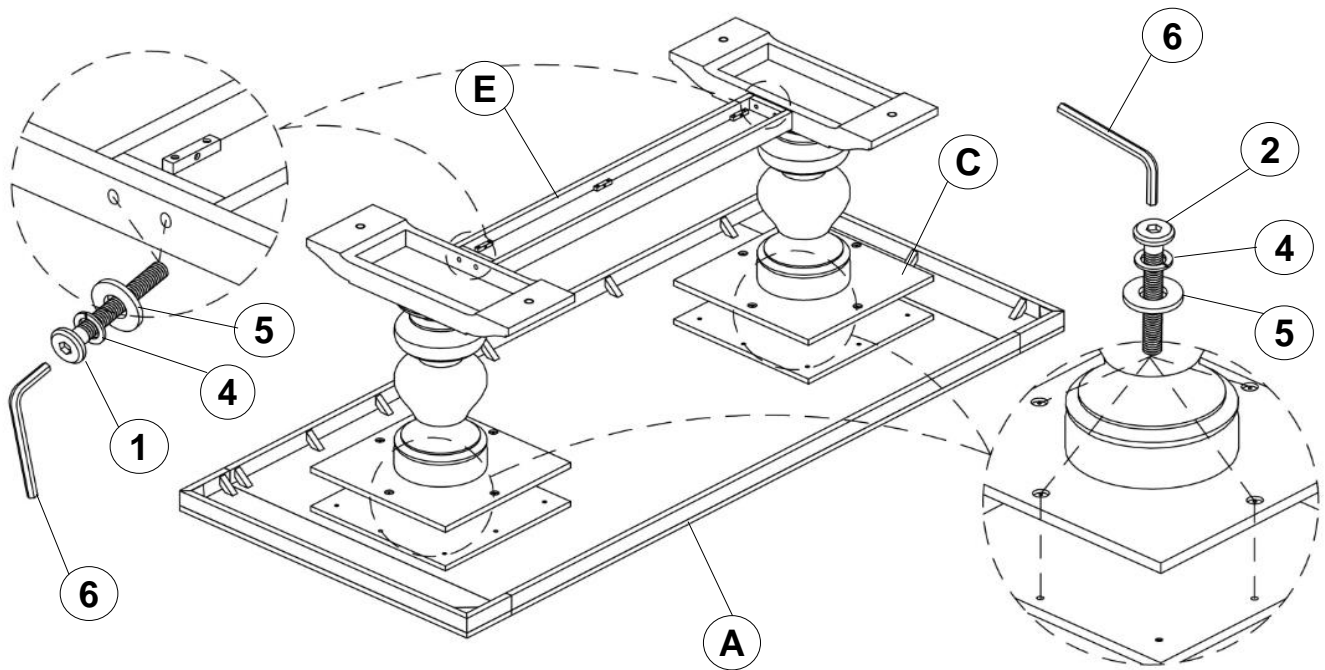

STEP 4

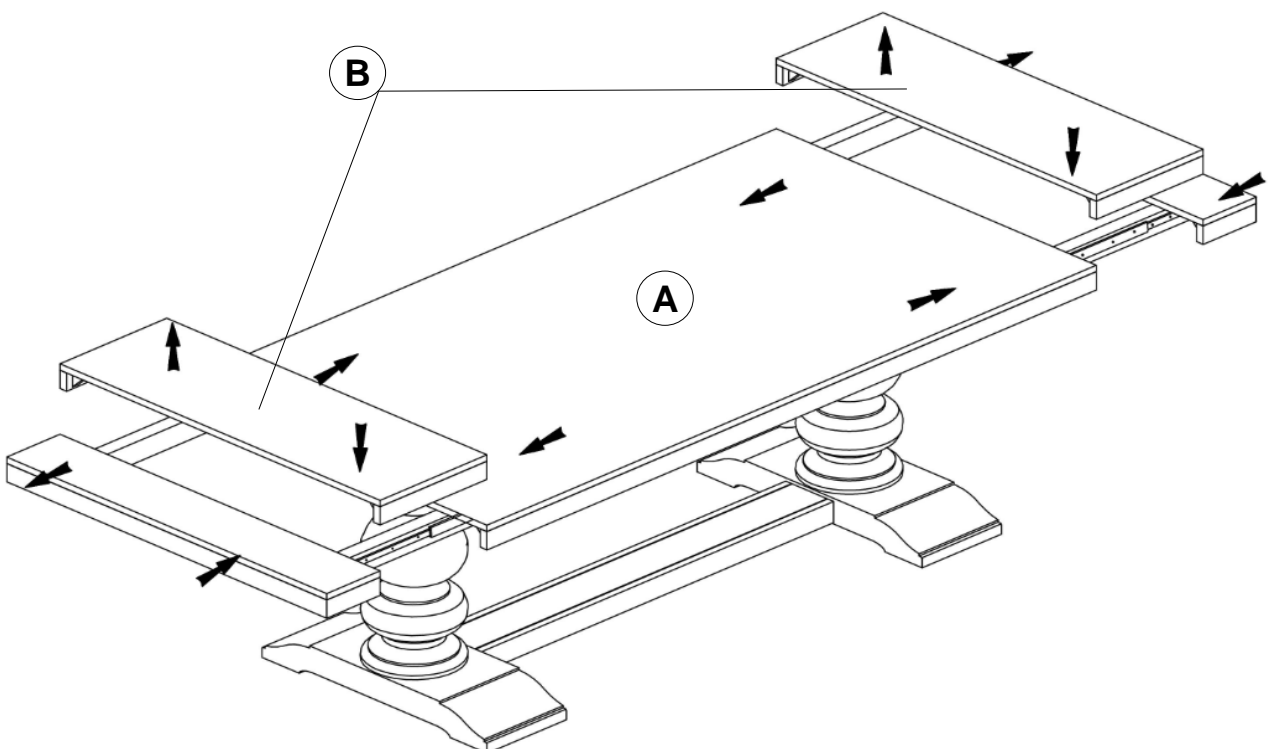

ITEM: **121231(B1&B2)**



ASSEMBLY INSTRUCTIONS

STEP 5

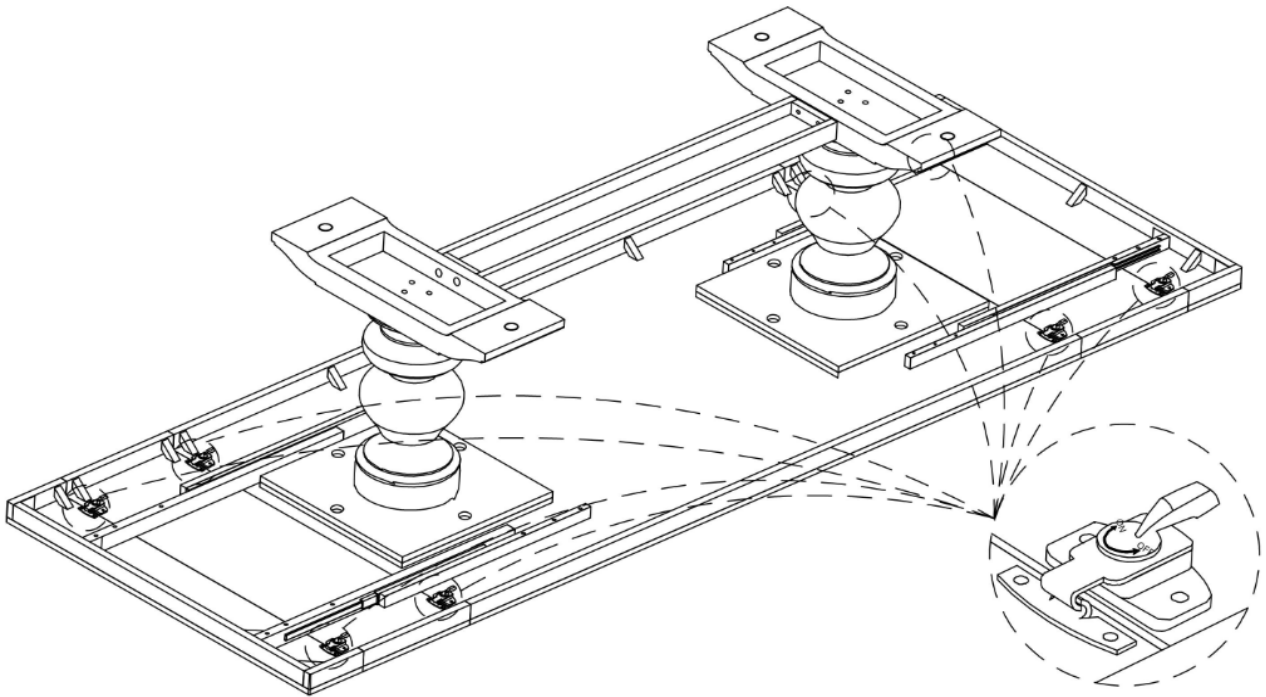

STEP 6

COMPLETE

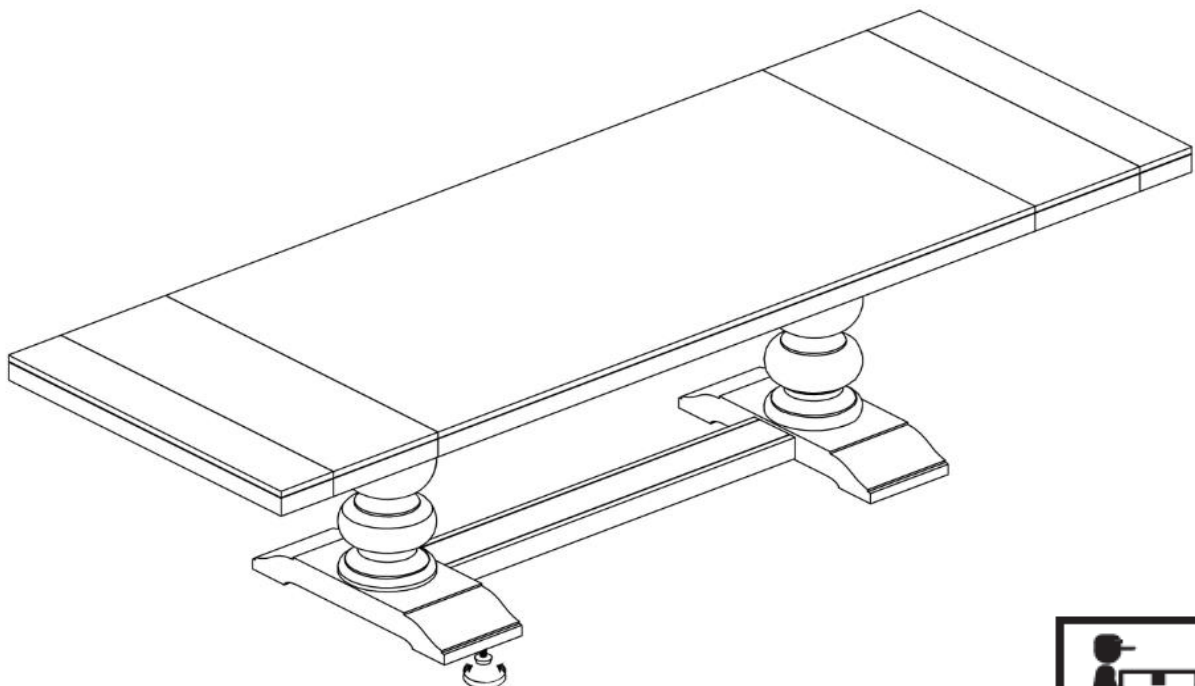

ADJUSTABLE LEVELER



ITEM: 121231(B1&B2)

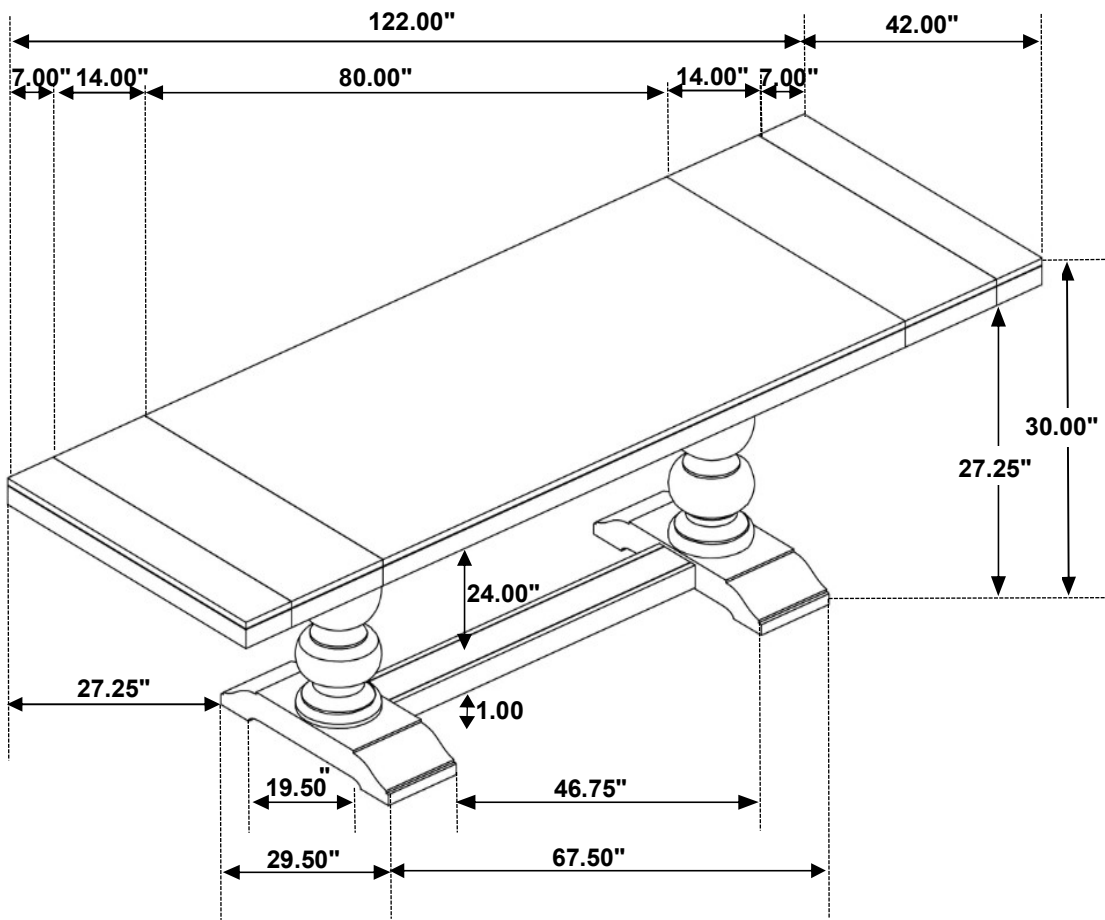

Note: Dimension tolerance $\pm 5\%$

ASSEMBLY INSTRUCTIONS
COASTER FINE FURNITURE



Fine Furniture for every stage of life

121714
Dining Chair

ITEM: **121714**

ASSEMBLY INSTRUCTIONS

ASSEMBLY TIPS:

1. Remove hardware from box and sort by size.
2. Please check to see that all hardware and parts are present prior to start of assembly.
3. Please follow attached instruction in the same sequence as numbered to assure fast and easy assembly.



WARNING !

1. Don't attempt to repair or modify parts that are broken or defective. Please contact the store immediately.
2. This product is for home use only and not intended for commercial establishment.



ASSEMBLY TIME

15 MINUTES

PARTS IDENTIFICATION

AD

SEAT AND BACK

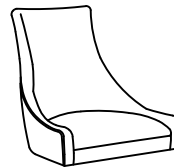

1PC

BD

FRONT LEG

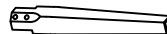

2PCS

CD

BACK LEG



2PCS

HARDWARE IDENTIFICATION

1

LONG BOLT
(M8 x 60mm - BLK)



8PCS

2

LOCK WASHER
(M8 - BLK)



8PCS

3

FLAT WASHER
(M8 - BLK)



8PCS

4

ALLEN WRENCH
(M5 - BLK)



1PC

ITEM: **121714**
ASSEMBLY INSTRUCTIONS

STEP 1

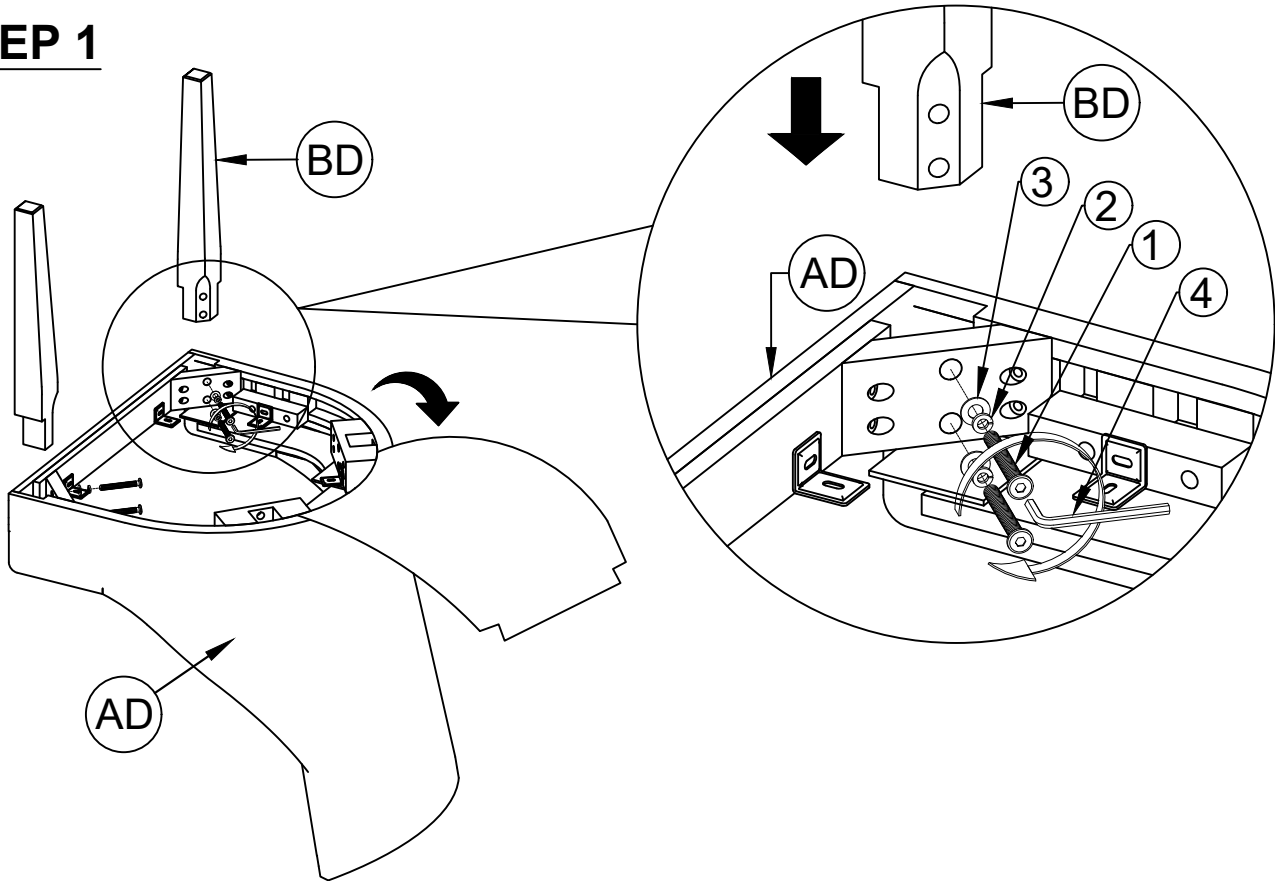

STEP 2

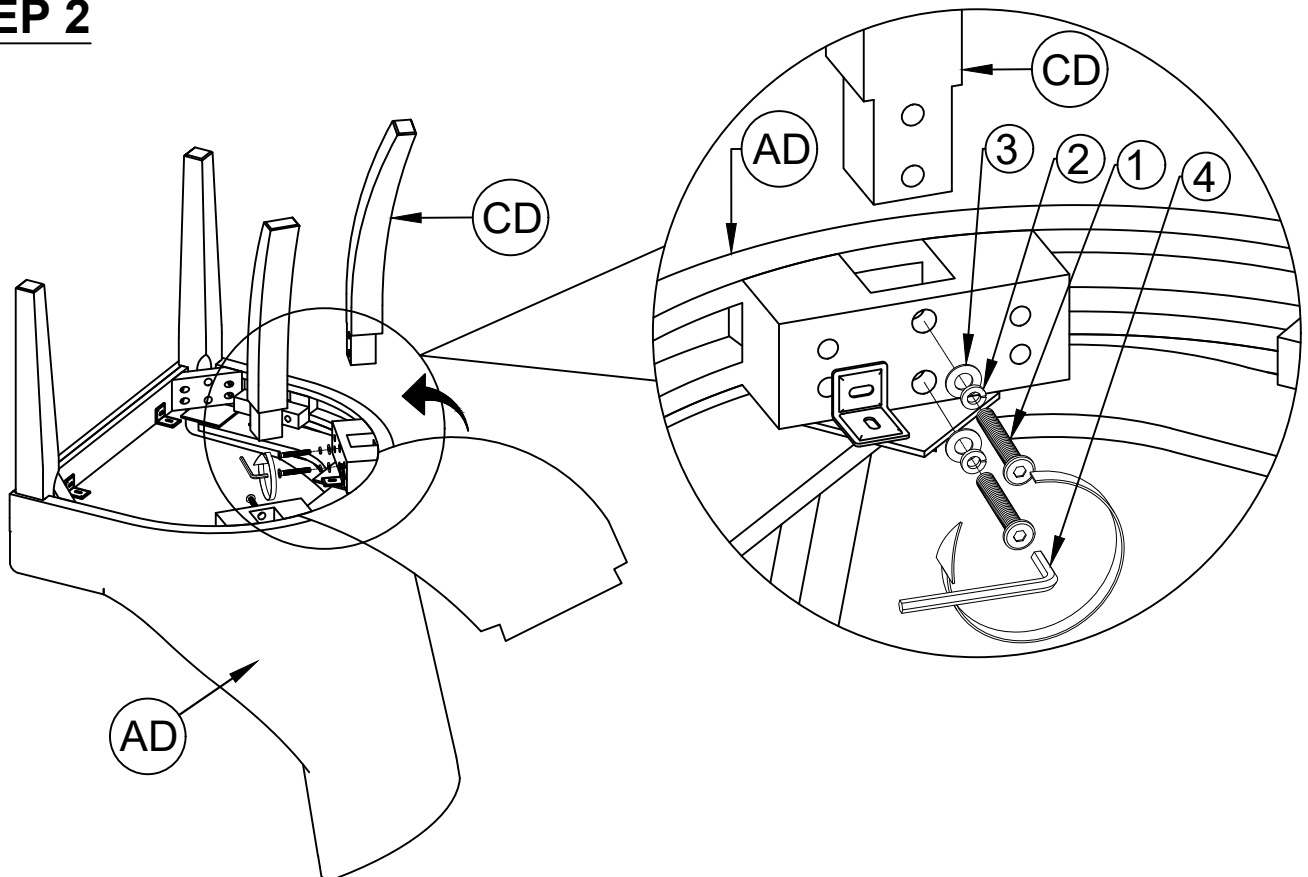

ITEM: **121714**
ASSEMBLY INSTRUCTIONS



STEP 3
COMPLETE

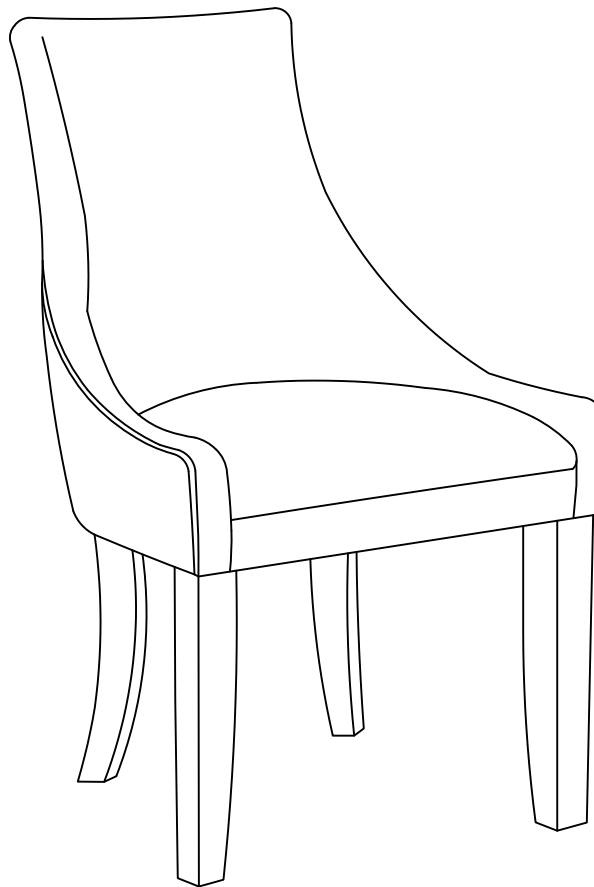

ITEM: 121714

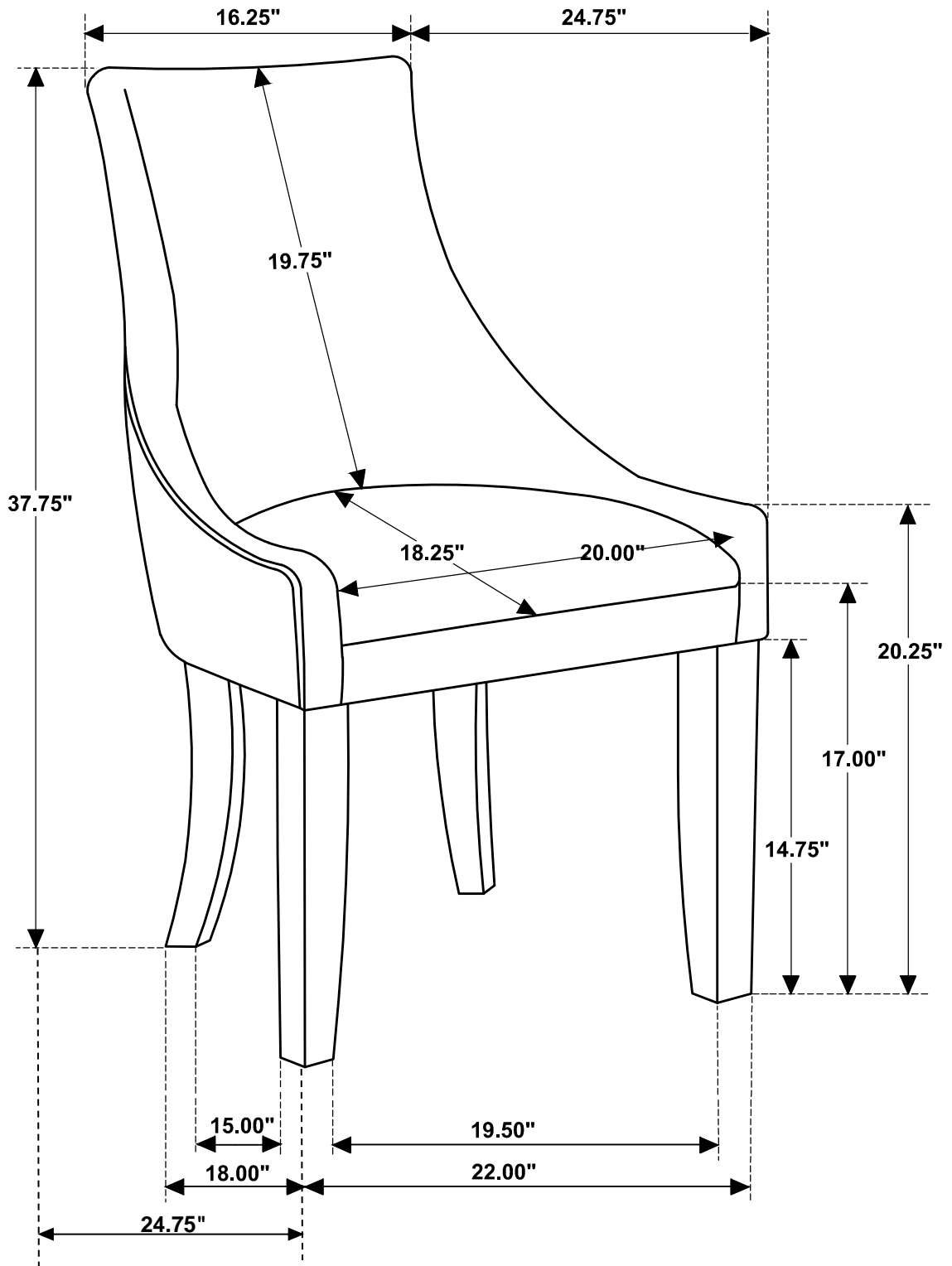

Note : Dimension tolerance $\pm 5\%$