

ZY810
ZY820

工業用縫紉機

使用說明書

(含零配件圖)

FOR 810

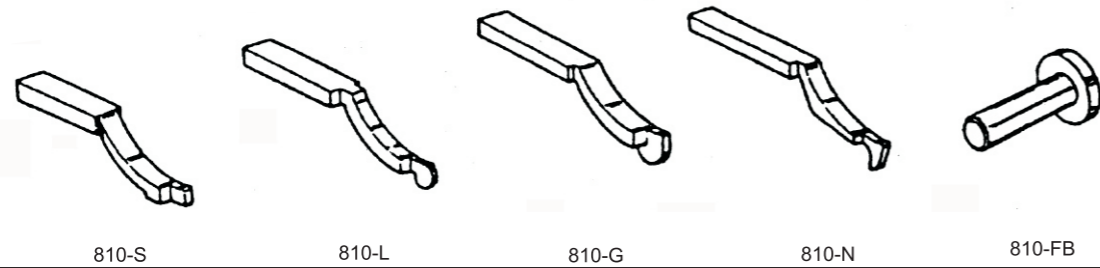

FOR 820

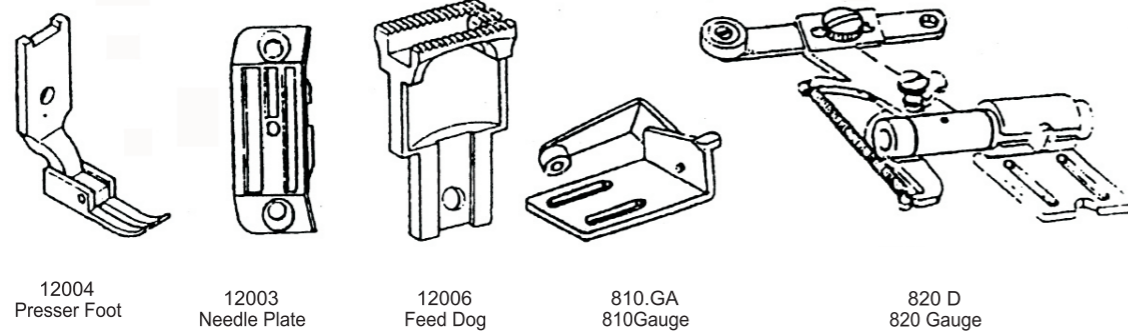
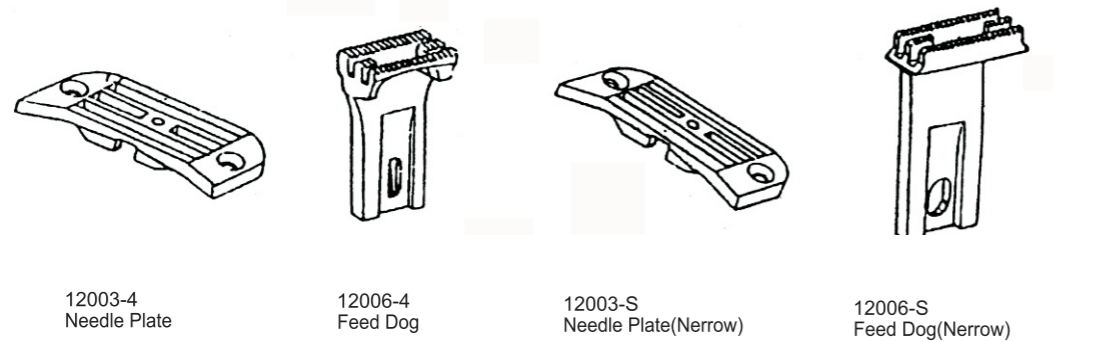
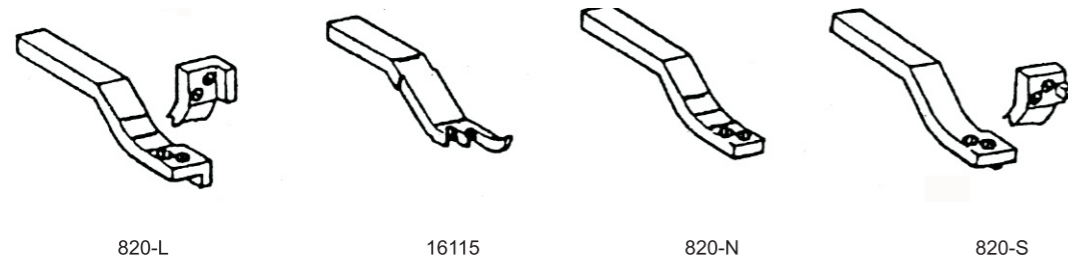

INSTRUCTION MANUAL FOR POST-BED INDUSTRIAL SEWING MACHINE

This manual is prepared to permit the sewing machine to be used efficiently and for highest performance. This machine is post-bed industrial sewing machine suitable for sewing shoes, bags, caps and general leather works. You can either select 1-needle or 2-needle machine according to your type of works. Being equipped with spring return reverse lever type feed mechanism opener type vertical hook, and slide type thread take-up provides perfect uniformed stitching.

-INDEX-

Specification.....	2
Main parts name of machine head.....	3
I. Preparation for installation of machine.....	4
1). Place of installation of machine.....	4
2). How to mount the machine head.....	4
3). How to mount the motor.....	4
4). How to connect the motor lever and foot pedal.....	4
5). How to mount the bobbin winder assembly.....	4
6). How to mount and adjust the knee lifter mechanism.....	5
7). How to mount the oil pan.....	6
8). How to mount the vibration preventing rubber.....	6
II. Preparation for operation.....	7
1). Selection of thread.....	7
2). How to attach the needle.....	7
3). How to lead the upper thread.....	8
4). How to wind the lower thread on the bobbin.....	9
5). How to adjust the bobbin winder assembly.....	10
6). How to place the bobbin into the book.....	11
III. How to operate.....	13
1). Starting to sewing.....	13
2). Sewing over.....	13
IV. Stitching adjustment.....	14
1). Adjustment of stitch length.....	14
2). Forward and Reverse stitching.....	14
3). Adjustment of thread tension.....	14
4). Adjustment of feed dog height and pressure of presser on materials.....	17
5). Proper timing between the hook and needle.....	18
6). Proper timing between the hook and opener.....	21
7). Proper timing between the feed dog and needle.....	22
V. Cleaning and Lubrication.....	23
1). Cleaning.....	23
2). Lubrication.....	23
3). Grease.....	24

特別配件組

SPECIAL PARTS

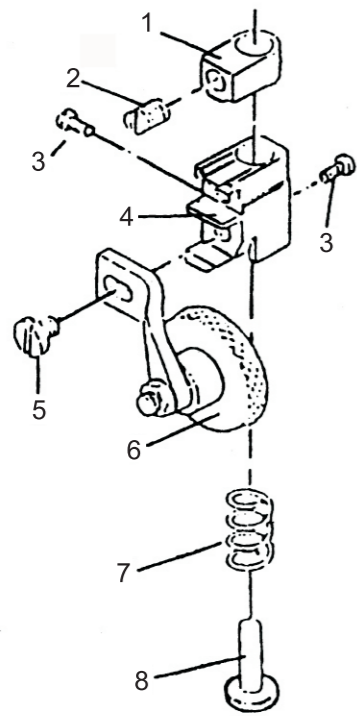

907

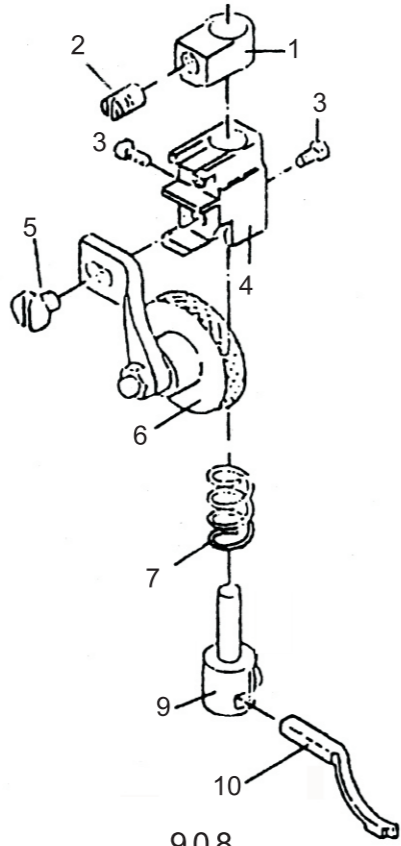

908

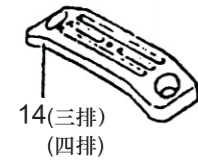
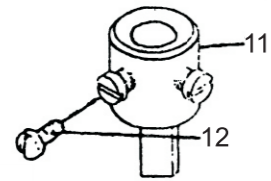

14(三排)
(四排)

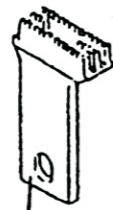
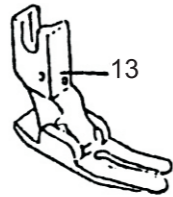

15(三排)
(四排)



* Main parts name of machine head

(Two Needle Type)

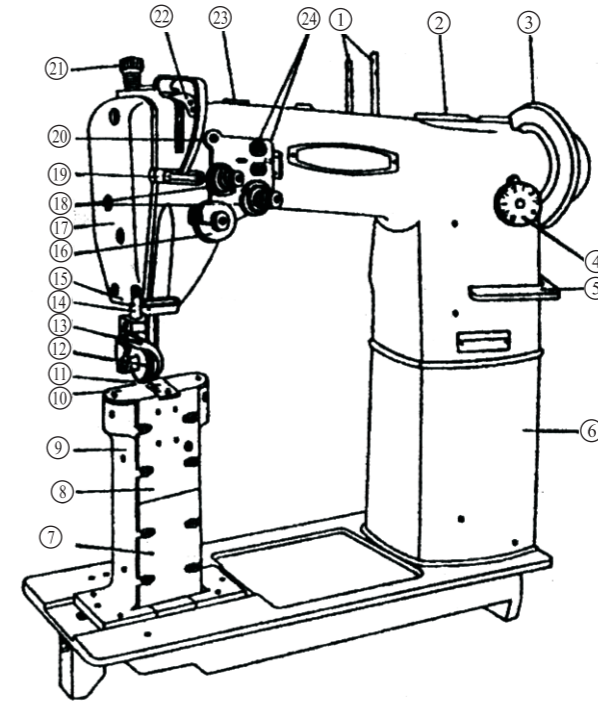

- | | | |
|----------------------------------|-----------------------------|-------------------------------------|
| (1) Spool pin | (9) Hook shaft bracket | (17) Face plate |
| (2) Oil reservoir(right) | (10) Slide plate | (18) Thread tension regulator |
| (3) Balance wheel | (11) Needle plate | (19) Thread guide(upper) |
| (4) Stitch regulating dial | (12) Roller foot | (20) Thread take up lever guard |
| (5) Reverse lever | (13) Needle guide | (21) Presser regulating thumb screw |
| (6) Post | (14) Presser bar | (22) Thread take up lever |
| (7) Hook post cover plate(lower) | (15) Thread guide(lower) | (23) Oil reservoir(left) |
| (8) Hook post cover plate(upper) | (16) Thread controller disc | (24) Pre-tension |

* Preparation for installation of machine head

I PREPARATION FOR INSTALLATION OF MACHINE HEAD

1. PLACE OF INSTALLATION OF MACHINE.

The machine should be installed on well-leveled floor in order to ensure smooth operating of your machine at high speed without vibration.

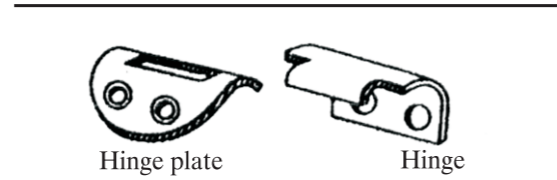

2. HOW TO MOUNT THE MACHINE HEAD ON TO THE TABLE.

Install the hinge with screws, provided in accessory, at hole on the back of the bed and hook to the hinge plate of the table, then the head is set on the table.

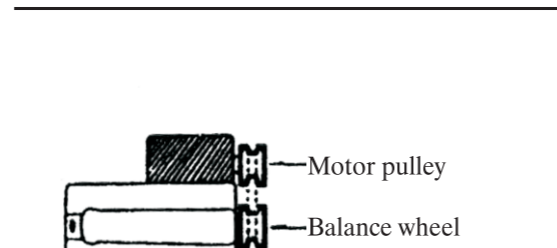

3. MOUNTING OF THE MOTOR.

- ◆ The motor is mounted generally with bolts, nuts, and washers as provided.
- ◆ Set the position so that the motor pulley and balance wheel grooves are aligned straight as shown in Fig. For proper operation when the belt is inserted.
- ◆ Then connect power supply cord and motor cord extended from switch.

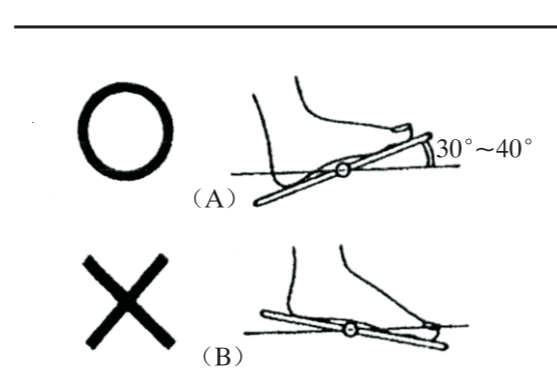

4. HOW TO CONNECT THE MOTOR LEVER AND FOOT PEDAL.

- ◆ The angle of the slope of the pedal can be important. It can make a difference in the strength necessary to press the pedal.
- ◆ There might be a slight difference in operator's posture, but generally 30° - 40° angle as shown in Fig.(A) is considered best.
- ◆ The treadle position shown in Fig.(B) will be difficult. In this case, adjust the length of the connecting rod to suit the operator.

5. HOW TO MOUNT THE BOBBIN WINDER ASSEMBLY.

- ◆ Set the position of the bobbin winder assembly provided in accessory, to be in parallel with the belt hole of the table, with the lever pushed in operation position.
- ◆ When bobbin winder pulley will come in contact with the belt, fix the assembly onto the table with two screws provided, as shown in Fig.

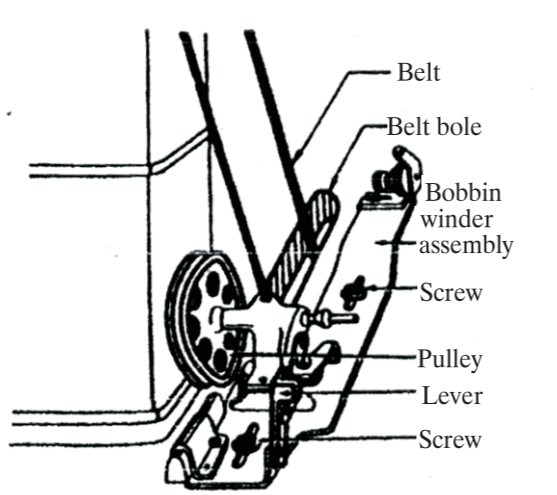

給油機構部分

OIL LUBRICATION MECHANISM

Fig. No.	Part No. 零件號碼	Code No. 料號	部 品 名	Name of Part	個/台 Amt.rep	
					810	820
800	81023800-000	MF 60A5 749	附件盒	Accessory box	1	1
801	81023801-000	MF 60A0 419	橡膠墊	Vibration preventing rubbers	4	4
802	81023802-000	MN 10A0 561	後鈕片	Hinge(2)	2	2
803	81023803-000	M9 0501 040	螺絲	Screw	4	4
804	81023804-000	MF 60A0 137	油壺	Oiler(large)	1	1
805	81023805-000		針#16	Needle	4	6
806	81023806-000	MB 02A1 608	螺絲起子(小)	Screw driver(small)	1	1
807	81023807-000	MB 02A0 608	螺絲起子(中)	Screw driver(middle)	1	1
808	81023808-000	M9 1601 003	後鈕螺絲	Screw	4	4
809	81023809-000	MN 10A0 060	後鈕扣	Hinge(1)	2	2
810	81023810-000	MV 01A0 778	壓墊	Bed presser	1	1
811	81023811-00A	M9 0570 080	柱塞	Rubber plug	1	1
812	81023812-000	M9 0401 041	螺絲	Screw	2	2
813	81023813-000	M9 0608 050	華司	Washer	2	2
814	81023814-000		螺釘	Nail	8	8
815	81023815-000	MN 10A0 123	梭子	Bobbin	4	6
816	81023816-000	MF 20E0 190	卷綫架	Bobbing winder	1	1
817	81023817-000	MV 01E0 727	脚弓組	Knee lifter	1	1
818	81023818-000	M9 0501 040	螺絲	Screw	1	1
819	81023819-000	MF 60A0 734	車頭蓋	Vinly cover	1	1
820	81023820-000	MQ 70A0 131	油盤	Oil reservoir	1	1
821	81023821-000	MF 60A0 608	螺絲起子(大)	Screw driver(large)	1	1

ACCESSORIES

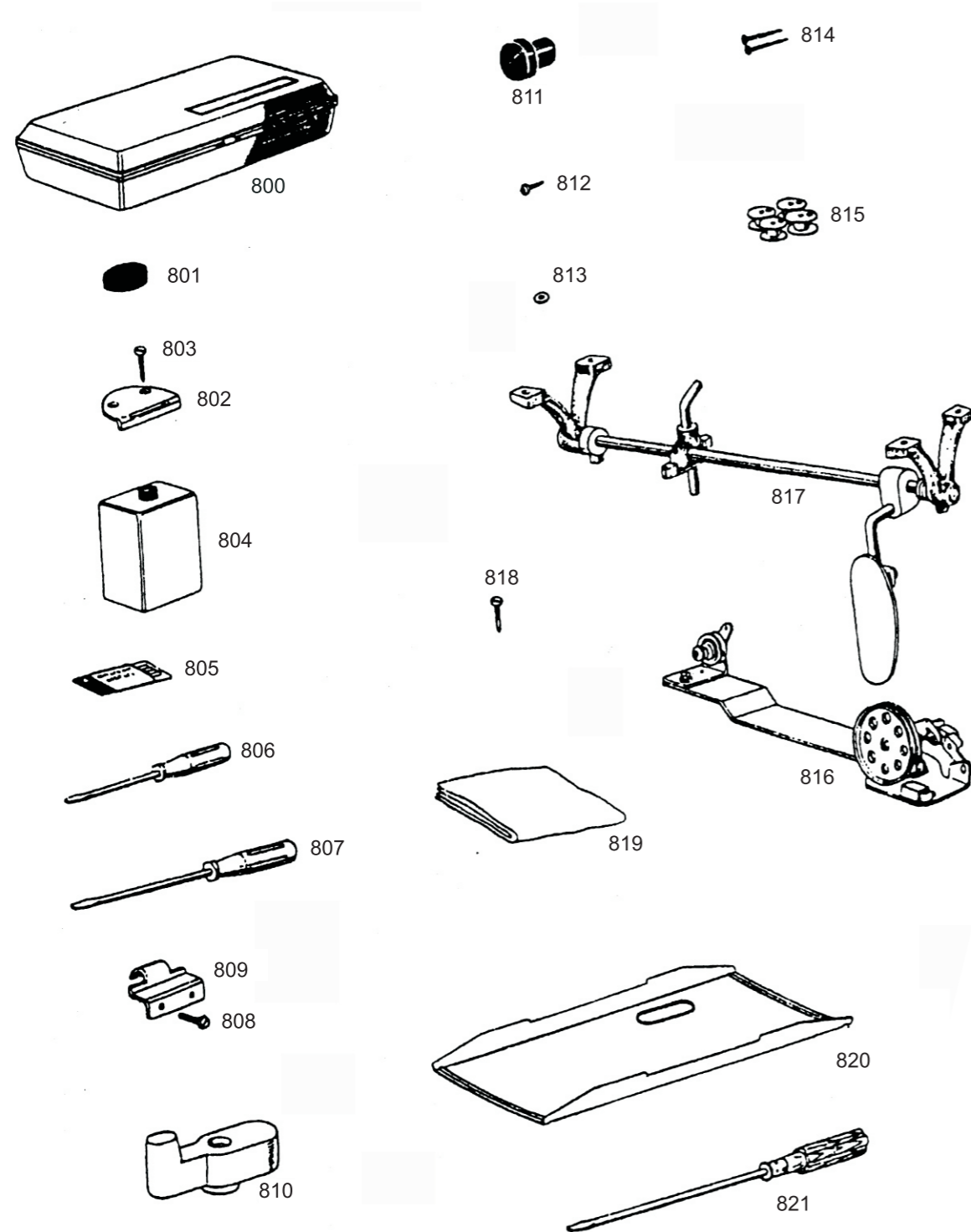

* Preparation for installation of machine head

6. HOW TO MOUNT AND ADJUST THE KNEE LIFTER MECHANISM.

- ◆ The knee lifter mechanism is employed to raise and lower the presser bar.
- ◆ Mount it properly onto the table by following method for easy operation.
- ◆ If improperly installed, the operating action will be heavy and tire the operator.

1) Place of mounting.

- ◆ Make a hole for knee lifter shaft bracket underneath the table according to Fig. Shown.

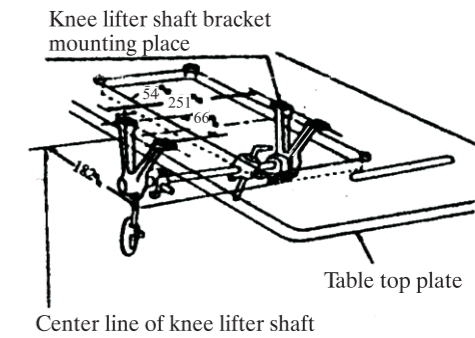

2) How to mount.

- (1) Mount the knee lifter. Shaft bracket while the side of hole for spring towards your side as shown in Fig.
- (2) The other side of the knee lifter shaft bracket is screwed so as able to insert the
- (3) On the knee lifter shaft, mount the knee lifter position bracket, regulating rod bracket, knee plate bar bracket, and spring in the order mentioned, then tighten respectively.
- (4) Mount the knee lifter shaft, on which fixed respective parts, on the shaft bracket.
- (5) After checking up all the parts and inclination of the knee lifter shaft, tighten the shaft bracket screws.
- (6) The shorter side of knee plate bar is mounted on the bar bracket, and longer side of the bar is mounted on the knee plate.
- (7) The end of spring is inserted into a hole of the shaft bracket(front).
- (8) The other end of spring is placed on the knee plate bar moving it.
- (9) After mounting all these parts, check whether the knee lifter mechanism can be operated lightly.

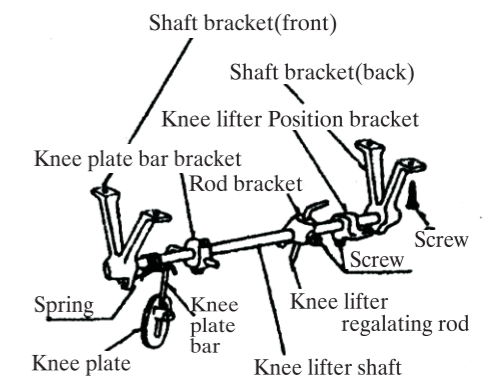

*** Preparation for installation of machine head**

3) Adjustment.

(1) Place of knee lifter position bracket.
 Since the position bracket makes standardize the starting point of knee plate, tighten the screw at the proper position so that the stopper of position bracket come contact with top underneath of the shaft bracket (back).

(2) Positon of the knee lifter bell crank regulat-
 ing rod and its bracket.

◆ The regulating rod makes raise and down the
 presser foot by means of moving the bell
 crank lever up and down.

◆ While the presser foot downed, adjust the
 length (A) loosening the regulating rod
 screw so that the rod and crank lever
 contacts with as shown in Fig.

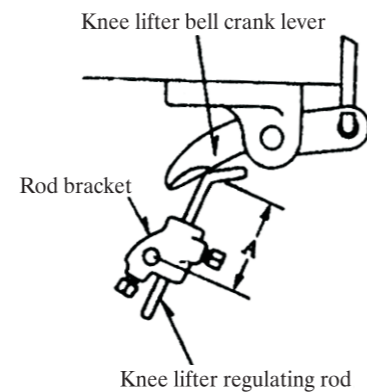

7. HOW TO MOUNT THE OIL PAN.

Fit the oil pan with mails into the hole bored in
 the table so as not to come into contact with
 the knee lifter mechanism.

8. HOW TO MOUNT THE VIBRATION
 PREVENTING RUBBER.

The vibration preventing rubber is used to
 prevent the machine from vibrating and there-
 by provide smooth operation of the maching.
 Fit these rubber insulators properly at the
 four corners of the table as shown in Fig.
 Remember, the machine will vibrate if these
 are not monnted properly.

(1) Hollow out four comers of the table 20mm
 radius and 13mm depth to fit the rubber
 insulators.

* Be sure to give smooth surface to "A"
 where hollow out is made.

(2) Nail the vibration preventing rubbers down
 at the four corners.

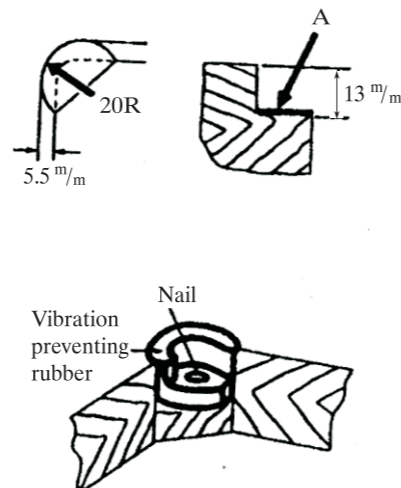

GAUGE PARTS

Fig. No.	Part No. 零件號碼	Code No. 料號	部 品 名	Neme of Part	Gauge Size						
					3/64	1/16	3/32	1/8	1/4		
					1	12	16	24	32	64	
600	81021600-000	MV 02J0 101	針板	Needle plate	1						
601	81021601-000	MV 02J1 101	針板	Needle plate		1					
602	81015054-000	MV 02J2 101	針板	Needle plate			1				
603	81021603-000	MV 02J3 101	針板	Needle plate				1			
604	81021604-000	MV 02J4 101	針板	Needle plate					1		
605	81021605-000	MV 02J8 101	針板	Needle plate						1	
606	81015249-000	MV 02J0 101	狗齒	Feed dog	1	1	1	1			
607	81021607-000	MV 02J4 104	狗齒	Feed dog					1		
608	81021608-000	MV 02J8 104	狗齒	Feed dog						1	
609	81021609-000	MV 02J0 102	針樞	Needle clamp	1	1					
610	81021610-000	MV 02J2 102	針樞	Needle clamp			1				
611	81021611-000	MV 02J3 102	針樞	Needle clamp				1			
612	81021612-000	MV 02J4 102	針樞	Needle clamp					1		
613	81021613-000	MV 02J8 102	針樞	Needle clamp						1	
614	81021614-000	MV 02J0 102	押脚	Presser foot	1	1	1	1	1		
615	81021615-000	MV 02J0 105	押脚	Presser foot							1
616	81021616-000	MV 02A0 103	針檔	Needle guide	1	1	1				
617	81021617-000	MV 02A0 103	針檔	Needle guide	1	1	1				
618	81021618-000	MV 02J3 103	針檔	Needle guide				1			
619	81021619-000	MV 02J4 103	針檔	Needle guide						1	
620	81021620-000	M9 6601 052	墊片0.6t	Washer	1	1				1	
621	81021621-000	M9 6602 052	墊片0.8t	Washer			1				
622	81021622-000	M9 6603 052	墊片1.2t	Washer				1	1		

GAUGE PARTS

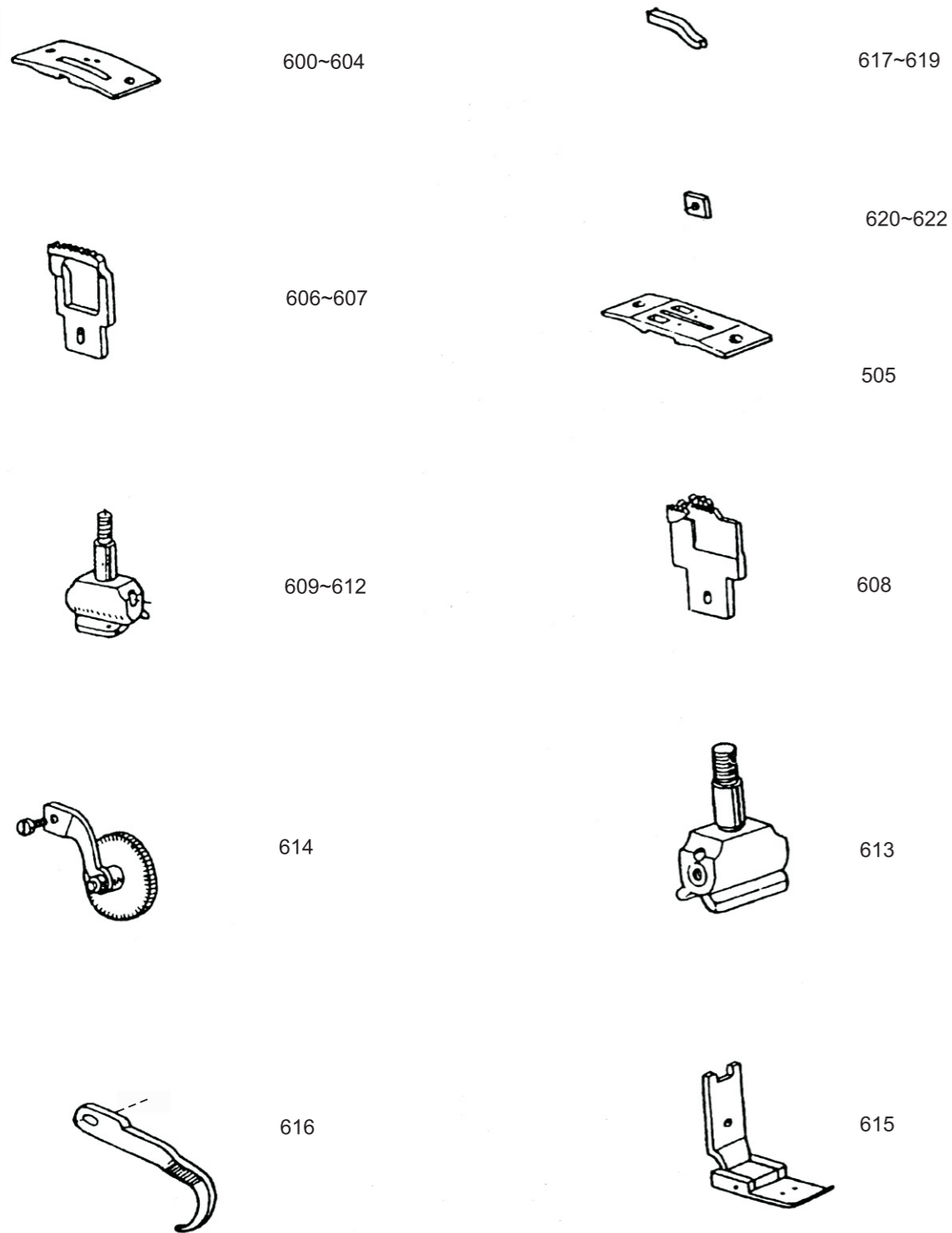

* Preparation for operation

II. PREPARATION FOR OPERATION.

1. SELECTION OF THREAD.

- ◆ For best results, use high quality machine thread.
- ◆ For upper thread use left-twist thread.
- ◆ To check whether a thread is left-twist or right-twist, hold the thread as shown in Fig. and twist the thread held in the right hand toward your side. If the thread twist becomes loose, the thread is right-twist, and if the thread twist becomes tight the thread is left-twist.

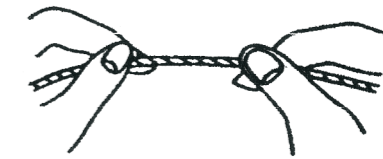

2. HOW TO ATTACH THE NEEDLE.

- ◆ Dpx5(135x5) type needle is recommendable for general use.
- ◆ But select the needle size that meets the requirements of the materials sewn and the thread used.

For One Needle Type

- (1) While the presser bar lifter is raised, turn the balance wheel by hand to raise the needle bar to its highest position.
- (2) Move the roller foot to the left as shown in Fig.
- (3) Loosen the needle clamping screw.
- (4) Hold the needle to its side with the long groove side(left). Then insert the needle as deeply it will go into the needle clamping hole.
- (5) Securely tighten the needle clamping screw.

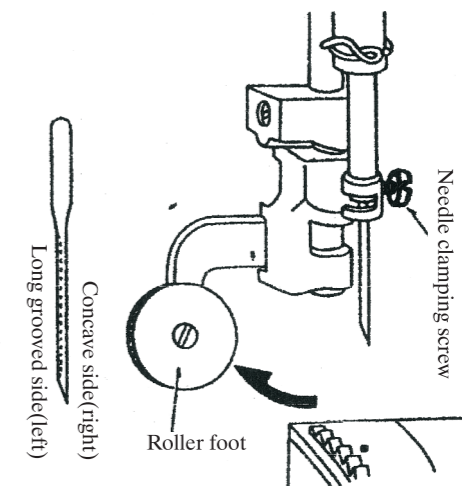

For Two Needle Type

- (1) While the presser bar lifter is raised, turn the balance wheel by hand to raise the needle bar to its highest position.
- (2) Move the roller foot to the left as shown in Fig.
- (3) Loosen the needle clamping screw.
- (4) Hold the needles so that the two needles side with the long grooved (faces each other), and insert it as deeply as it will go into the needle clamping holes.
- (5) Securely tighten the needle clamping screw.

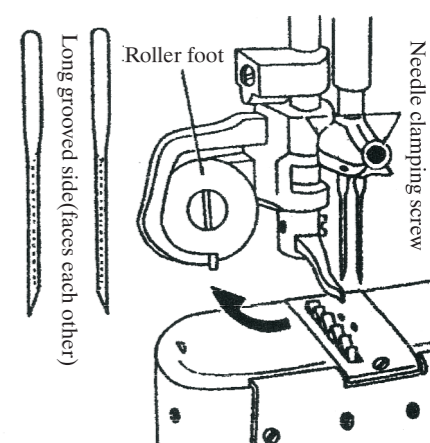

* Preparation for operation

* When using nylon or silk threads, the loops may be formed improperly or stitch skipping may result due to the twist of these threads. In this case, observe the condition of the loops and mount the needle in a manner that the needle hole would be positioned in a slightly oblique direction.

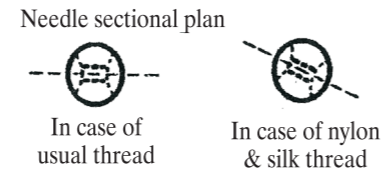

3. HOW TO THREAD THE UPPER THREAD.
For One Needle Type

- (1) Raise the thread take up lever to its highest position turning the balance wheel by hand.
- (2) After the presser bar lifter is raised, move the roller foot to the left holding downward as per arrow shown in Fig.
- (3) Thread in the following order:

1 Spool pin	9 Thread guide
2 Pre-tension	(Needle bar)
3 Thread retainer	10 Thread guide
4 Tension discs	(needle bar)
5 Thread take up spring	11 Needle
6 Thread guide(arm)	
7 Thread take up	
8 Thread guide(arm)	

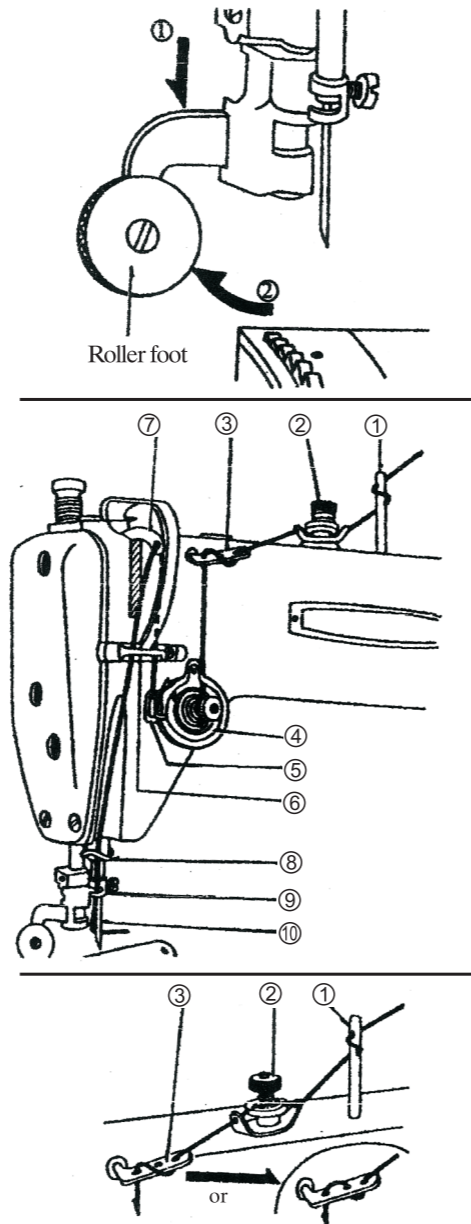

* The spool pin 1 with cross-shaped hole, pre-tension 2 and thread retainer 3 are provided to prevent the thread from twisting, so follow as shown in Fig.

* The tension discs 4 consists of two discs, pass the thread between these discs from the right to the left.

* For the thread take up spring 5, pass the thread from the right to the left.

* For the take up lever 7, pass it from the right to the left.

* For the needle 10, pass it from the left to the right.

給油機構部分

OIL LUBRICATION MECHANISM

Fig. No.	Part No. 零件號碼	Code No. 料號	部 品 名	Name of Part	個/台 Amt.rep	
					810	820
314	81019314-000	MF 60A5 740	油棉	Felt	1	1
315	81019315-000	MF 60A0 133	油蓋(左)	Oil cap(left)	1	1
911	81019911-000	MF 60E0 711	齒輪箱(上組)	Gear box(upper set)	1	1
316	81019316-000	M9 1851 002	螺絲	Screw(for gear box)	1	1
317	81019317-000		齒輪箱	Gear box	1	1
318	81019318-000	M9 0603 060	上齒箱梢	Gear box(upper)pin	1	1
319	81019319-000	M9 0906 011	螺絲	Screw (for Fig.320)	2	2
320	81019320-000	MF 60A0 134	蓋板	Cover plate	1	1
321	81019321-000	MF 60A4 740	油棉	Felt	1	1
322	81019322-000	MF 60A0 139	油棉槽	Oil tank(right)	1	1
323	81019323-000	MF 10E2 148	2.5 φ *150油棉心	Oil wick	2	2
326	81019326-000	M9 1110 002	螺絲	Screw	1	1
327	81019327-000	M9 1503 002	螺絲	Screw	1	1
912	81019912-000	MQ 50E0 712	齒輪箱(下組)	Gear box(lower set)	1	1
329	81019329-000	M9 1851 002	螺絲	Screw	1	1
330	81019330-000	M9 1503 002	螺絲	Screw	1	1
331	81019331-000	M9 1113 002	螺絲	Screw(for Fig.332)	2	2
332	81019332-000	MQ 70A0 710	齒輪箱	Gear box(lower)	1	1
333	81019333-000		齒輪箱	Gear box(lower set)	1	1

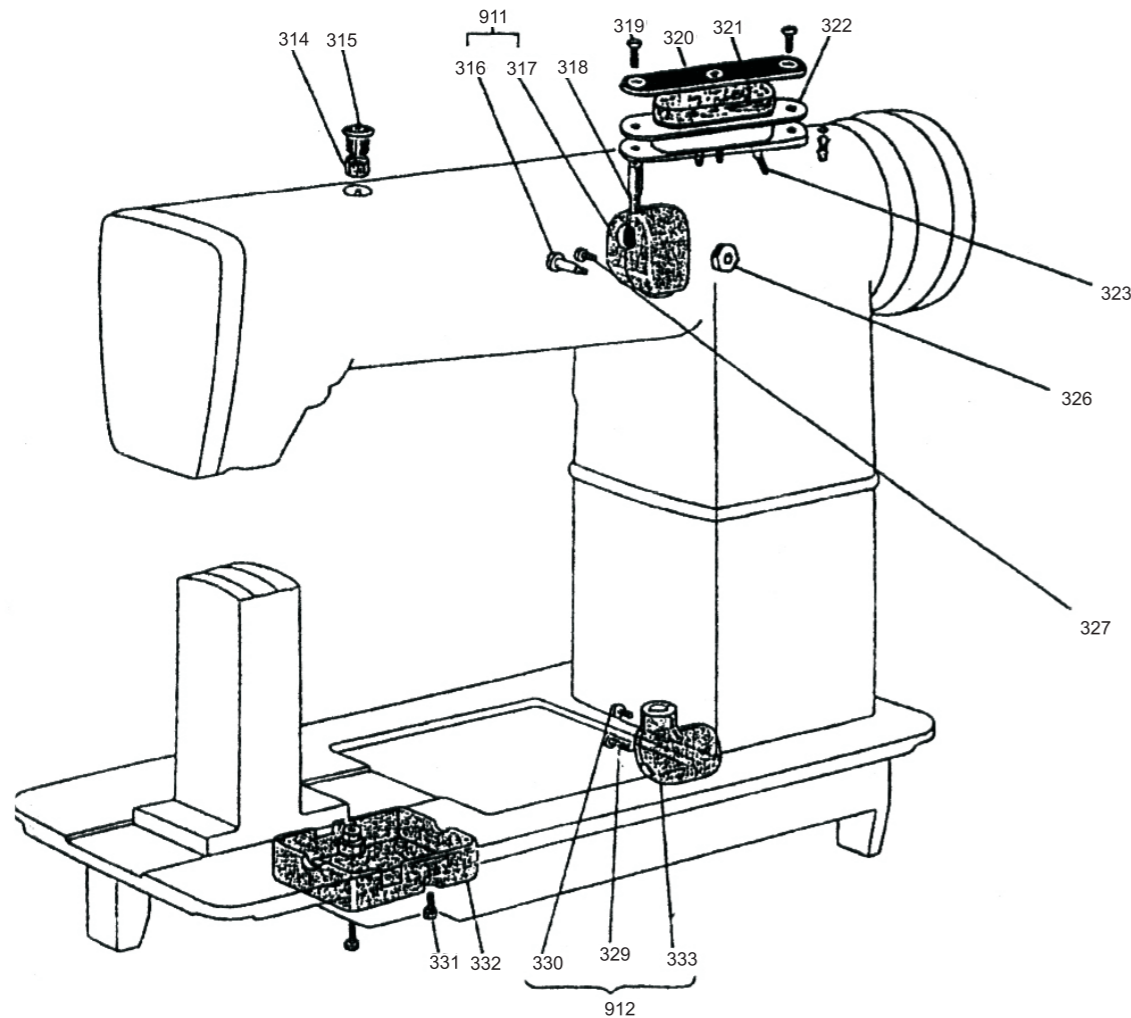

In case of Two Needle Type

- (1) Raise the thread take up lever to its highest position turning the balance wheel by hand.
- (2) In case of the roller foot, it is same order as one needle type did-move the roller foot to the left.
- (3) How to thread from the cotton stand spool (left).

- | | |
|------------------------------------|-------------------------------|
| L1 Spool pin(left) | 6 Thread take up spring |
| L2 Thread guide (Upper) | 7 Thread guide (upper) |
| L2' Thread guide pin(right) | L8 Take up lever (upper hole) |
| L3 Pre-tension (upper) | 7 Thread guide (upper) |
| L3' Thread guide pin(left) | 9 Thread guide (lower) |
| L4 Thread tension regulator(upper) | L10 Needle clamping(back) |
| L5 Thread controller disc(back) | L11 Needle(left) |

- (4) How to thread from the cotton stand spool (right).

- | | |
|------------------------------------|-------------------------------|
| R1 Spool pin(right) | 7 Thread guide (upper) |
| R2 Thread guide (lower) | R8 Take up lever (lower hole) |
| R3 Pre-tension (lower) | 7 Thread guide (upper) |
| R4 Thread tension regulator(lower) | 9 Thread guide (lower) |
| R5 Thread controller disc(front) | R10 Needle clamping(front) |
| 6 Thread take up spring | R11 Needle(right) |

* To the pre-tension 3 and tension regulator 4 thread between these discs.

* To the two needles 11., Thread from the inside to outside.

4. HOW TO WIND THE LOWER THREAD ON THE BOBBIN.

- (1) Thread from the spool through the hole of the thread guide 1 to the tension discs 2.
- (2) Wind the end of the thread through the tension discs 2 on the bobbin about 5-6 times.
- (3) Fit the bobbin into the bobbin pin 3 in a manner so that the thread can be wound on the bobbin from the underside.
- (4) Push the lever toward the other side so that the pulley and the belt will engage.
- (5) Operate the machine so that the thread can be wound on the bobbin.
- (6) The bobbin winder will automatically be free from the belt when the bobbin is fully wound with thread, and stopped.

* This operation can be done while working.

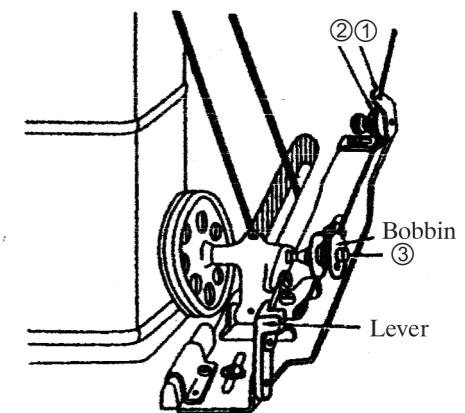
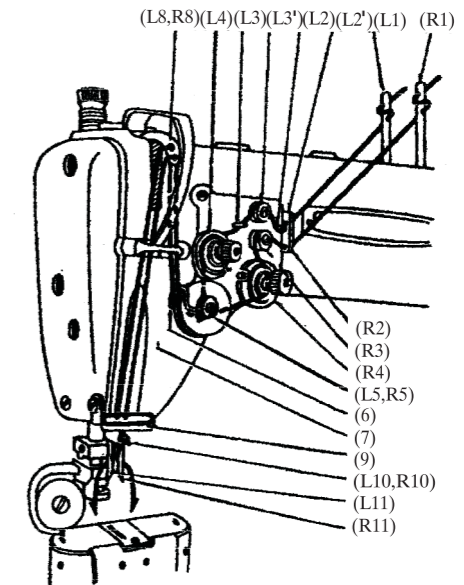

* Preparation for operation

5. HOW TO ADJUST THE BOBBIN WINDER ASSEMBLY.

◆ It is desirable that the bobbin is wound evenly with thread as shown in Fig. (A) , but Fig. (B) & (C) shown are not proper winding.

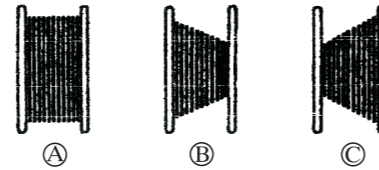

◆ Adjust the bobbin winder assembly in the following order so as able to wind the thread onto the bobbin properly.

1) In case of uneven winding.

◆ In the event of uneven winding toward the left, loosen the screw (A) of the thread guide, and adjust it moving the thread guide slightly to the right.

◆ In the event of uneven winding toward the right, adjust it moving the guide to the left.

◆ After adjusted, tighten the screw (A) of the thread guide.

2) Winding strength of thread.

◆ When the thread (Particularly nylon thread) is wound too tightly, there is a tendency to unwind the thread on a bobbin.

◆ In this case adjust the pressure of tension discs with nut (B) so that thread can be pulled out smoothly.

2) Winding amount of thread.

◆ Best results are obtained when the bobbin is wound up to 4/5 of its full capacity with thread. Excessive winding will results in poor pull-out of the thread.

◆ In the event of excessive winding, turn the screw(C) to the left, and to the right when insufficient.

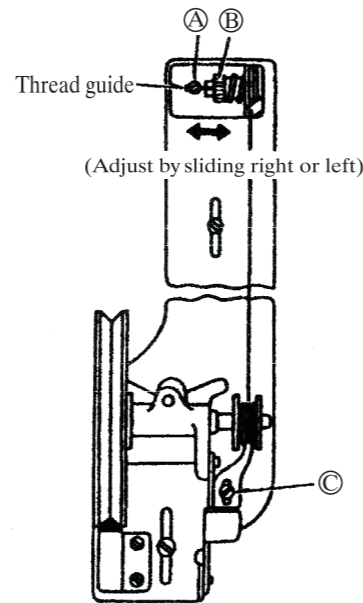

梭頭機構部分

HOOKMECHANISM

Fig. No.	Part No. 零件號碼	Code No. 料號	部 品 名	Name of Part	個/台 Amt.rep	
					810	820
280	81017280-000	MV 01A0 355	梭頭軸	Hook shaft	1	2
910	81017910-000	MV 01A0 120	梭頭組	Hook Assy	1	2
281	81017281-000		梭頭	Hook	1	2
282	81017282-000		護針片	Noodle bracket	1	2
283	81017283-000	MF 10A0 123	梭子	Bobin	1	2
284	81017284-000	M9 0904 010	螺絲	Screw(for Fig.280)	1	2
285	81017285-000	MQ 70A0 470	滑蓋	Slide plate	1	2
286	81017286-000	MG 2300 740	油墊	Felt	1	2
287	81017287-000	MV 01A0 356	梭頭軸支座	Hook shaft supporter	1	2
288	81017288-000	MV 01A0 303	牛角底座	Rotating hook opener bracket	1	2
289	81017289-000	MV 01A0 300	牛角	Rotating hook opener	1	1
290	81017290-000	M9 1809 015	螺絲	Screw(for Fig.289)	1	2
291	81017291-000	M9 0912 002	螺絲	Screw(for Fig.289)	2	4
292	81017292-000	M9 1113 003	螺絲	Screw	1	2
293	81017293-000	M9 0903 010	螺絲	Screw (for Fig.295-297)	8	
294	81017294-000	M9 0920 003	螺絲	Screw (for Fig.295-297)		16
295	81017295-000	MV 01A1 339	蓋板	Cover plate	1	
296	81017296-000	MV 02A2 339	蓋板	Cover plate		1
297	81017297-000	MV 02A0 339	蓋板	Cover plate		1
298	81017298-000	MQ 70A0 352	梭頭杆套環	Hook shaft collar	1	2
299	81017299-000	M9 1651 001	螺絲	Set screw(for Fig.298)	2	4
300	81017290-000	MQ 70A0 330	斜齒輪	Bevel gear	1	2
301	81017301-000	M9 1109 001	螺絲	Set screw(for Fig.302)	1	2
302	81017302-000	MQ 70A0 341	梭頭軸襯套	Hook shaft bushing	1	2
303	81017303-000	MQ 70A1 330	梭頭軸斜齒輪	Hook shaft bevel gear(lower)	1	2
304	81017304-000	M9 1606 001	螺絲	Set screw(for Fig.303)	4	8

HOOK MECHANISM

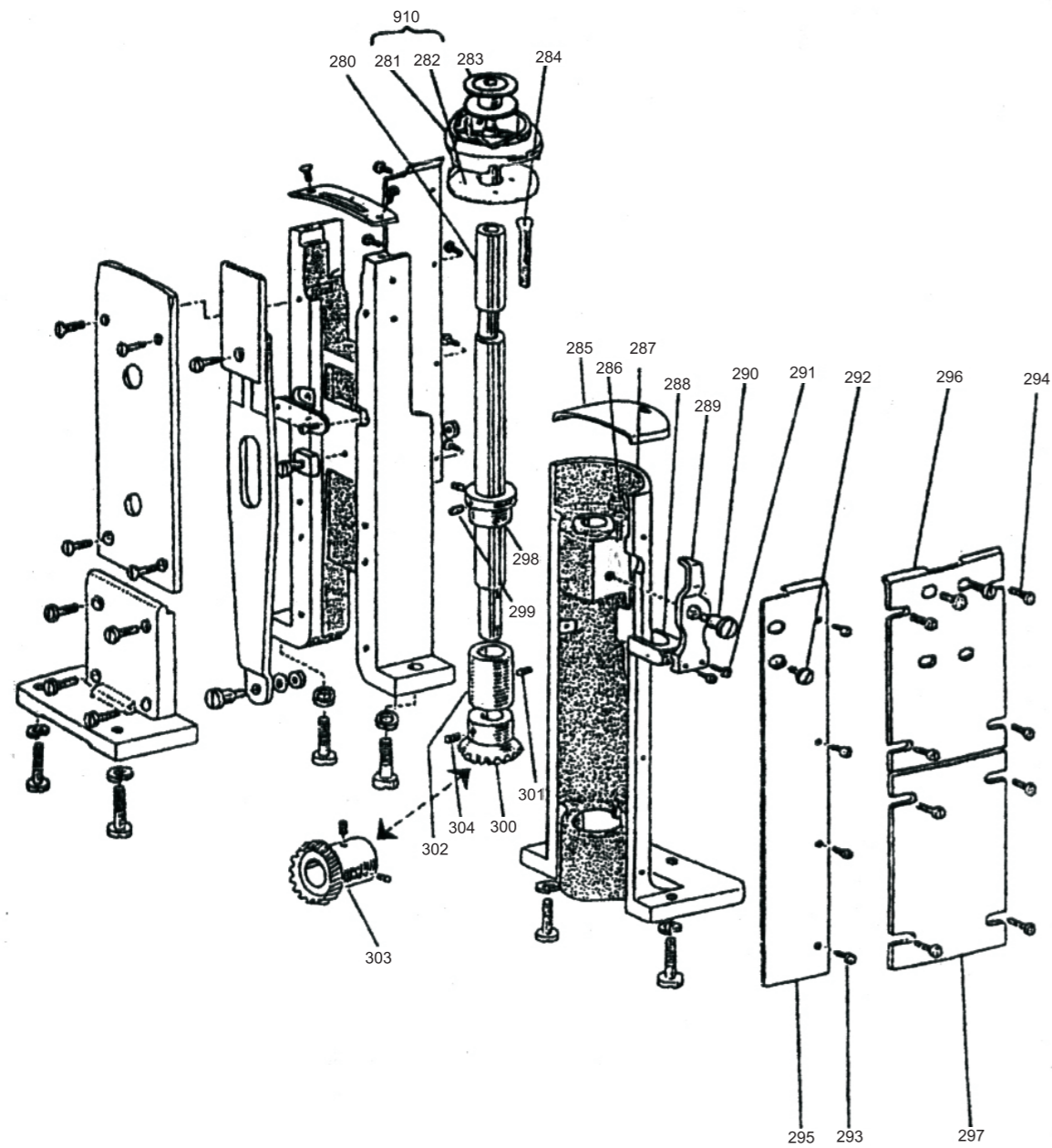

* Preparation for operation

6. HOW TO PLACE THE BOBBIN INTO THE HOOK.

In case of One Needle Type

- (1) Raise the needle bar to its highest position turning the balance wheel by hand.
- (2) Move the roller foot to the left as shown in Fig.
- (3) Move the slide plate.
- (4) Turn up the latch lever as shown in Fig.
- (5) Pull the bobbin thread for about 5cm, hold it like in the illustration.

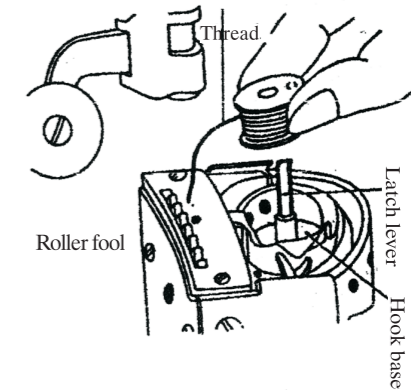

- (6) Fit the bobbin, into the hook base.
- (7) Flap down the latch lever.
- (8) Insert the pulled out thread end through the slit (1) in the hook body.
- (9) From the slit (1) pass the thread underneath the hook body (2), and pull it to the right diagonally, and the thread will pass through tension spring.
- (10) Leave the end of thread inserted through to the tension spring as it is.

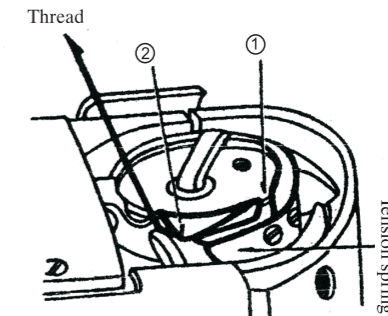

- (11) While holding the end of upper thread by left hand, turn the balance wheel slowly once around by right hand.
- (12) Then the upper thread will hook out the lower thread simultaneously through the hole of needle plate, and leave the lower thread to other side of the needle plate.
- (13) After placing the bobbin, close the slide plate.

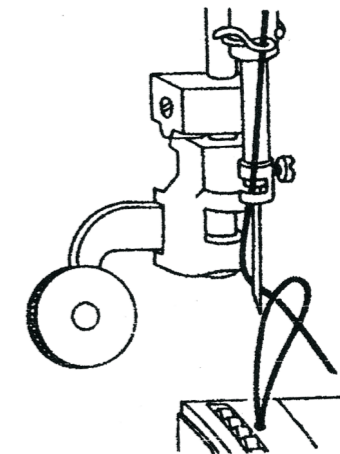

* Preparation for operation

In case of Two Needle Type

- (1) Raise the needle bar to its highest position turning the balance wheel by hand.
- (2) In the event of the roller foot is attached, move it to the left as shown in Fig.
- (3) Move the both slide plate.
- (4) Turn up the both of the latch lever as shown in Fig.
- (5) Pull out the bobbin thread for about 5 cm. And hold the bobbin.
- (6) Fit the bobbin into the both hook base.
- (7) Flap down the both latch lever as it was.
- (8) Insert the pulled thread end through slit (1) of the hook.
- (9) From the slit (1) of the hook, pass the thread through underneath of the hook body(2), pull the left thread to the left and the right thread to the right diagonally and the thread will pass through the tension spring as shown in Fig.
- (10) Leave the end of the thread inserted through the tension spring as it is.
- (11) While holding the end of 2-upper thread by left hand, turn the balance wheel slowly once around by right hand.
- (12) Then the 2-upper thread will hook out pulling the lower thread simultaneously through the hole of needle plate, and leave the lower thread to the other side of the needle plate as shown in Fig.
- (13) After placing the bobbin, close the both of the slide plate.

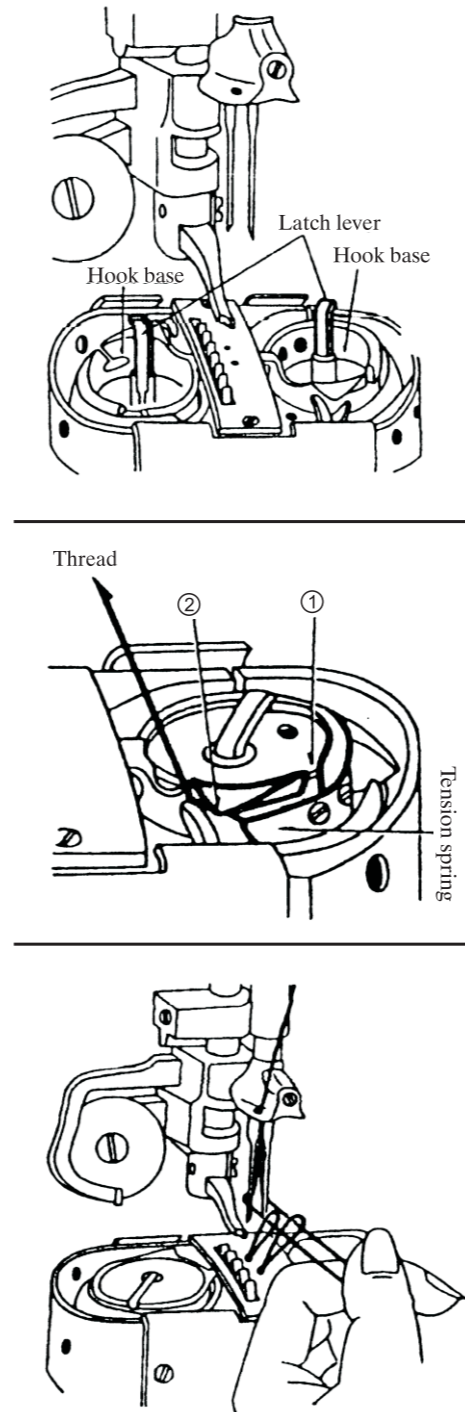

梭頭機構部分

HOOKMECHANISM

Fig. No.	Part No. 零件號碼	Code No. 料號	部 品 名	Name of Part	個/台 Amt.rep	
					810	820
245	81015245-000	M9 1110 002	螺絲	Screw(for Fig.246)	4	
246	81015246-000	MV 01A0 339	後蓋板	Rear cover plate	1	
247	81015247-000	M9 1107 002	螺絲	Screw(for Fig.248.249)	1	1
248	81015248-000	MV 01A0 104	狗齒	Feed dog	1	
249	81015249-000	MV 0200 104	狗齒	Feed dog(1/16)		1
250	81015250-000	MV 01A0 429	壓板	Supporter plate	1	1
251	81015251-000	MQ 70A0 603	中座	Feed plate set bracket	1	
252	81015252-000	MV 02A0 603	中座	Feed plate set bracket		1
253	81015253-000	MV 01A0 101	針板(單針)	Needle plate	1	
254	81015254-000	MV 0200 101	針板(1/16)雙針	Needle plate (1/16)		1
255	81015255-000	M9 0911 011	螺絲	Screw(for Fig.253.254)	2	2
256	81015256-000	M9 1251 045	螺帽	Nut	1	1
257	81015257-000	MQ 70A0 339	蓋板	Cover plate	1	
258	81015258-000	MV 02A1 339	蓋板(上後)	Cover plate		1
259	81015259-000	MV 02A0 339	蓋板(下後)	Cover plate(lower)		1
260	81015260-000	M9 0801 053	彈墊片	Spring washer	6	8
261	81015261-000	M9 2051 003	螺絲	Screw(for Fig.252)	6	6
262	81015262-000		螺絲	Screw(for Fig.250)	2	2
262-1	81015262-001		墊片	Washer	1	1
263	81015263-000	M9 1120 011	螺絲	Screw(for Fig.250)	2	2
264	81015264-000	MV 01A0 325	送料板滑塊	Square block	1	1
265	81015265-000	M9 1103 045	螺帽	Nut	1	1
266	81015266-000	M9 0502 053	彈簧華司	Spring washer	1	1
267	81015267-000	M9 1252 016	螺絲	Screw	1	1
268	81015268-000	M9 1112 015	螺絲	screw	1	1
269	81015269-000	MV 01A0 272	送料板	Feed plate	1	1
270	81015270-000	MQ 7010 563	直角臺	Side cover plate bracket	1	1
271	81015271-000	M9 1112 002	螺絲	Screw(for Fig.270)	4	

HOOK MECHANISM

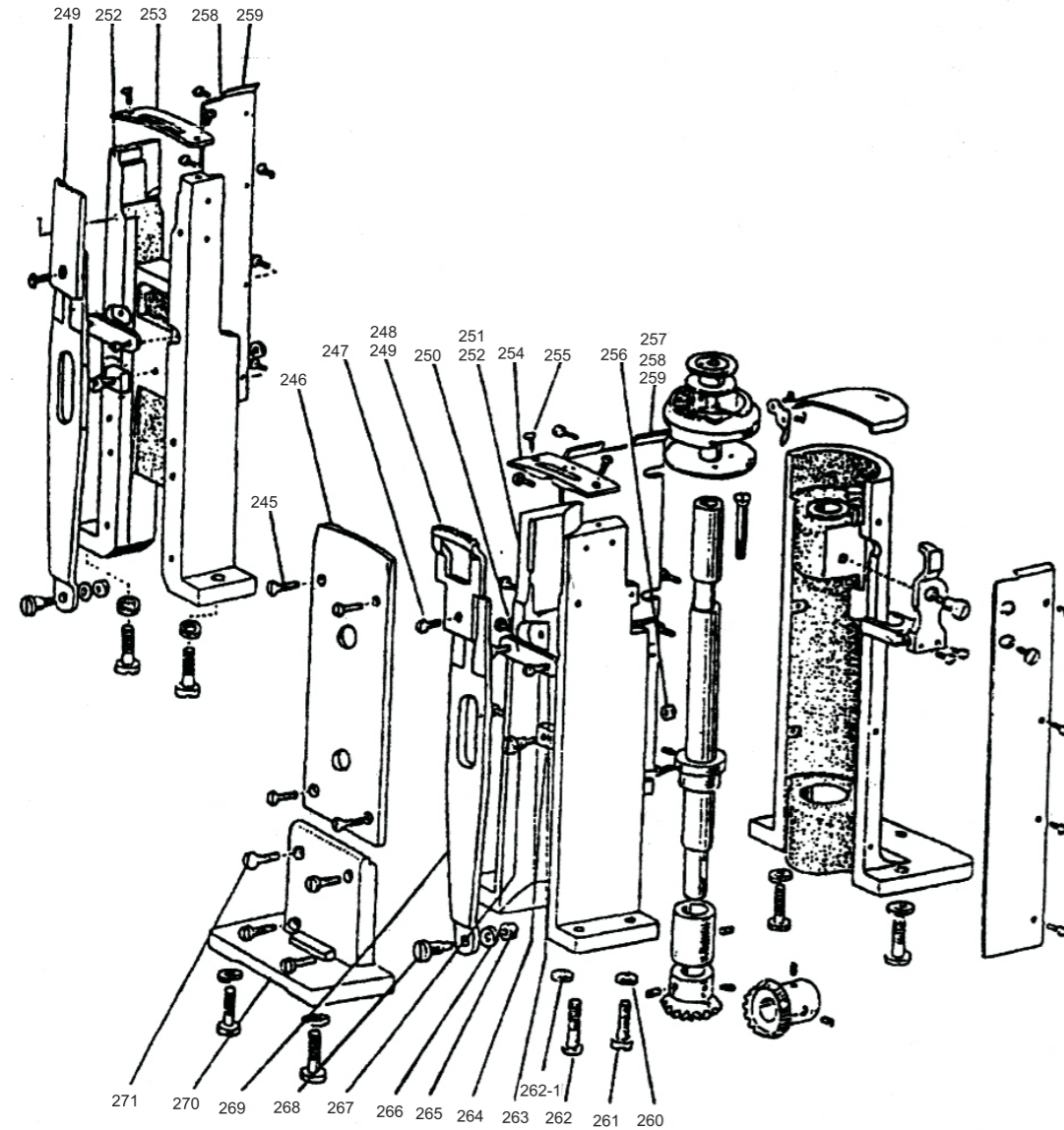

* Preparation for operation

III HOW TO OPERATE

1. STARTING TO SEWING.

- (1) Raise the presser bar lifter.
- (2) Move back the roller foot toward your side as shown in Fig. By the arrow.
- (3) Place starting end of the materials for stitching under the needles.
- (4) Turn the balance wheel by hand toward your side to that the needle stitches the materials.
- (5) Lower the presser bar lifter and start to sew.

* When starting to sewing, leave the upper thread pulled out by approx. 10cm in length so that it will not pull out from needle.

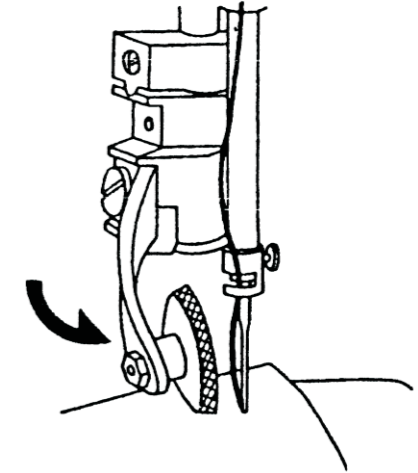

2. SEWING OVER.

- (1) Stop sewing when the take up lever comes to its highest position.
- (2) Raise the presser (roller or ordinary) foot.
- (3) Pull out the stitched fabrics diagonally to the left side.
- (4) Cut both upper and lower thread.

* When cutting the thread leave out approx. 10cm length so that next starting sew is convenient for you

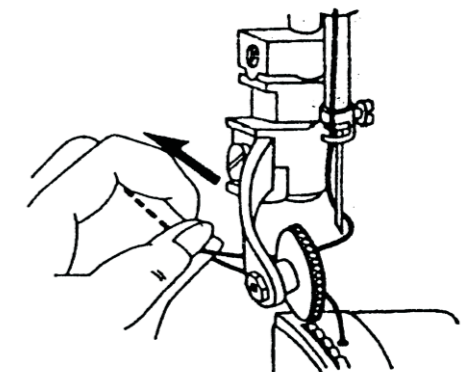

* Stitching Adjustment

IV. STITCHING ADJUSTMENT.

1. ADJUSTMENT OF STITCH LENGTH.

- ◆ Stitch length can be adjusted with the stitch regulating dial.
- ◆ Figures on the stitch regulating dial indicates the length in mm. When the dial number is set on the pin of the arm it will give your desired stitch length.

2. REVERSE STITCHING.

- ◆ Reverse stitching can be operated by means of pushing the reverse lever downward. While the lever is pressed downward, reverse stitching can be made.

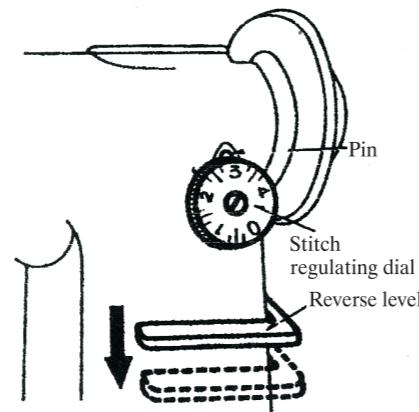

3. ADJUSTMENT OF THREAD TENSION.

- ◆ The thread tension varies according to the type of materials to be sewn, or thread used, and the length of the stitches required, so adjust the tension accordingly.
- ◆ If the upper and lower thread tension are well balanced, the two thread will link together in the middle of the fabric to provide perfect chain-like stitches (A) as shown in Fig.
- ◆ If, either the upper or lower thread tension is too tight, or too loose, it will give imperfect stitches such as (B) and (C) as shown in Fig.
- ◆ Fig. (B) shows the upper thread tension is too tight, and Fig. (C) the upper thread tension is too loose.

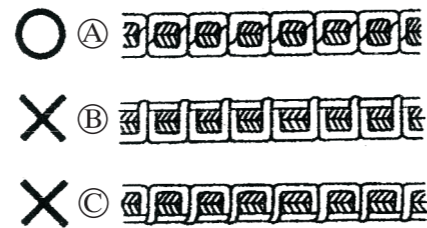

■ Tension of upper thread.

Adjustment of the upper thread tension can be achieved by changing the pressure of the tension discs of the regulator, as well as the strength and operating range of the thread take-up spring.

In case of One Needle Type

1) Pressure of the thread tension discs.

- ◆ For general fabric stitching, the desired tension can be obtained just by adjusting the pressure of the tension discs.
- ◆ To strengthen, turn the thread tension nut to the right.
- ◆ To slacken, turn to the left.

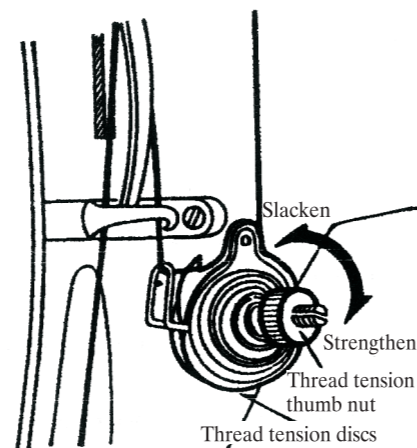

上軸, 上下軸部分

ROTATINGHOOKSHAFTANDFEEDLIFTINGROCKMECHANISM

Fig. No.	Part No. 零件號碼	Code No. 料號	部 品 名	Name of Part	個/台 Amt.rep	
					810	820
210	81013210-000	MF 10A0 286	水平軸套筒(左)	Feed rock shaft bushing(left)	1	1
211	81013211-000	M9 3001 052	墊片	Slide washer(for Fig.213)	1	1
212	81013212-000	M9 0606 050	墊片	Washer(for Fig.214)	1	1
213	81013213-000	MV 01A0 278	送料腕(左)	Feed rock shaft crank(left)	1	1
214	81013214-000	MV 01A0 281	送料土臺	Feed bar	1	1
217	81013217-000	M9 1110 002	螺絲	Set screw(for Fig.218)	2	2
218	81013218-000	MF 10A0 283	送料土臺支持軸	Feed bar shaft	1	1
218-1	81013218-001	MF 10A0 283	扣環	Ring	1	1
219	81013219-000	MF 65B0 491	水平軸	Feed rock shaft	1	1
220	81013220-000	MF 60A3 740	油墊	Felt	3	3
221	81013221-000	M9 1503 001	螺絲	Setscrew(for Fig.234)	2	2
222	81013222-000	MF 10A0 279	送料腕(右)	Feed rock shaft crank(right)	1	1
223	81013223-000	M9 0402 050	襯片	Washer(for Fig.224)	2	2
224	81013224-000	M9 1113 002	螺絲	Screw(for Fig.222)	5	5
225	81013225-000	M9 1108 001	螺絲	Set screw(for Fig.226)	1	1
226	81013226-000	M9 0901 060	送料腕、插梢(右)	Feed rock shaft connecting pin	1	1
227	81013227-000	MF 10A0 278	水平軸襯套	Feed rock shaft bushing(right)	1	1
228	81013228-000	M9 1513 001	螺絲	Screw(for Fig.227)	2	2
229	81013229-000	M9 2403 034	梢	Set pin(for feed rock crank rod)	2	2
230	81013230-000	M9 2402 045	螺帽	Nut(for Fig.229)	2	2
231	81013231-000	MV 01A0 452	軸襯套	Rotation hook shaft bushing(right)	1	1
232	81013232-000	NV 01A0 460	送料軸	Feed lifting rock shaft	1	1
233	81013233-000	MQ 70A0 450	下軸	Rotating hook shaft	1	1
234	81013234-000	MF 10A0 352	套環	Collar(for Fig.233)	1	1
235	81013235-000	MQ 70A0 452	下軸襯套(中)	Rotating hook shaft bushing(middle)	1	1
909	81013909-000		送料軸連杆組(左)	Feed lifting rock shaft crank(left)Assy	1	1
236	81013236-000	M9 1113 002	螺絲	Screw(for Fig.237)	1	1
238	81013238-000	M9 1112 002	螺絲	Screw(for Fig.213)	1	1
239	81013239-000	MF 67B0 451	下軸襯套	Rotating hook shaft bushing(left)	1	1

ROTATING HOOK SHAFT AND FEED LIFTING ROCK SHAFT MECHANISM

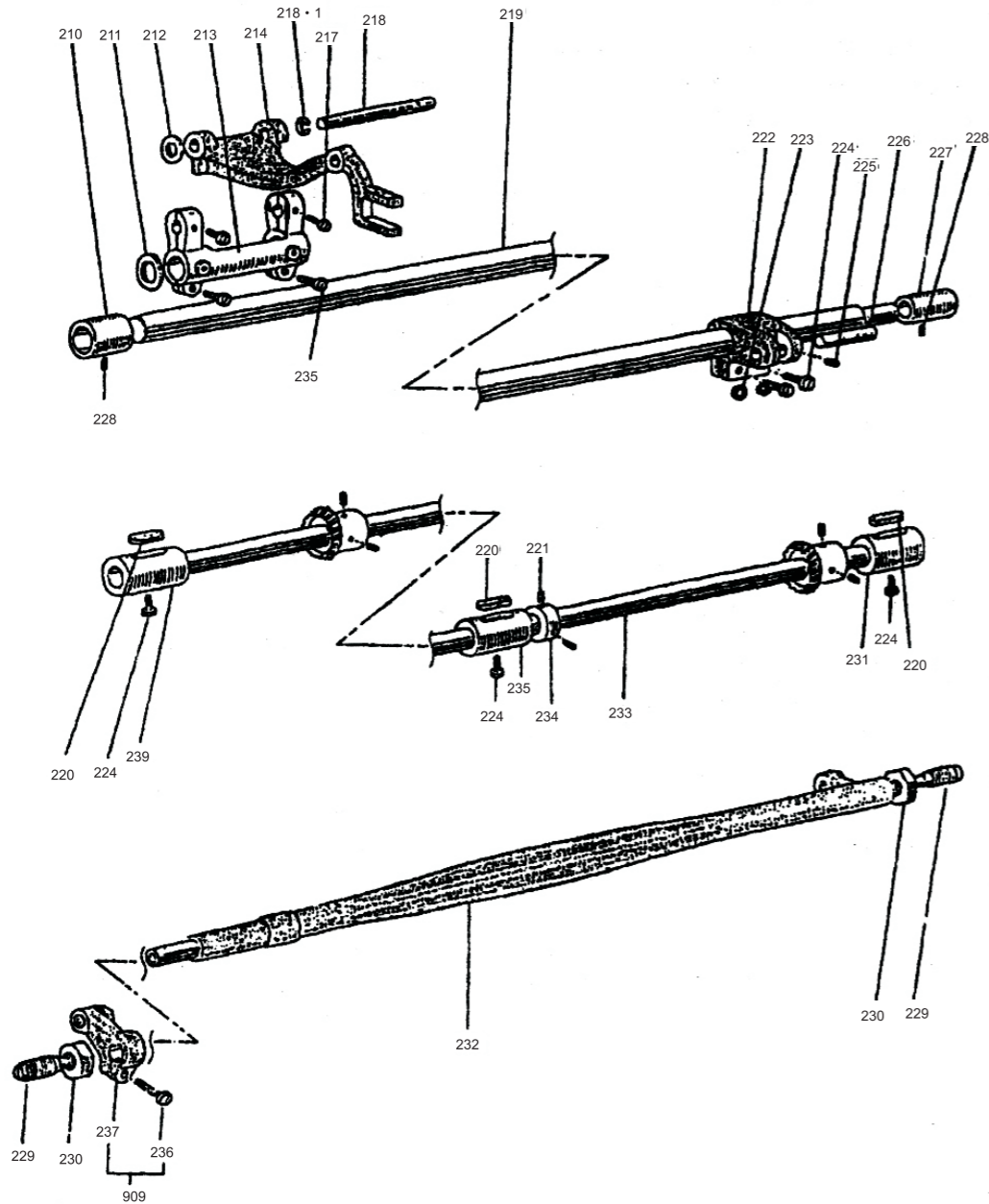

***Stitching adjustment**

In case of Two Needle Type

- ◆ To strengthen the pressure of thread tension discs, turn the thread tension nut to the right.
- ◆ To slacken, turn the tension nut to the left.

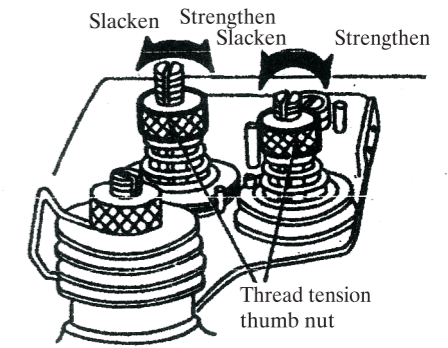

- 2) Strength of the thread take up spring.
 - ◆ Adjust the strength of the take-up spring according to the materials to be stitched.
 - ◆ Standard materials.....approx. 25g.
 - ◆ Light materials (small stitch length)
 - ◆ Heavy materials (large stitch length) strengthen the spring.....approx. 30g.

(In case of One Needle Type)

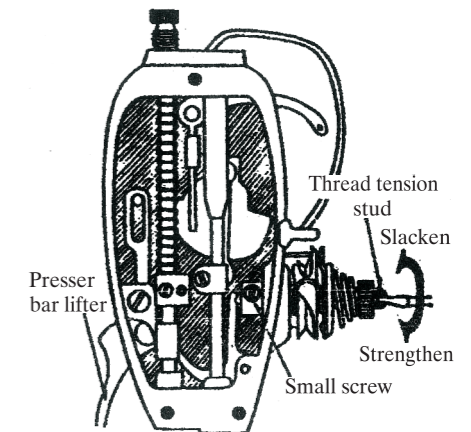

◆ How to adjust.

- (1) Leave the presser bar lifter down.
- (2) Remove the face plate.
- (3) Loosen the small screw inside of the face plate as shown of the upper thread tension regulator (one needle type) or of the thread tension controller (two needle type).
- (4) Fit the screw driver into the groove of the thread tension stud, or thread controller stub, and turn the stud to the left to strengthen, and to the right to slacken.
- (5) After adjusted, tighten the small screw and put the face plate back on.

(In case of Two Needle Type)

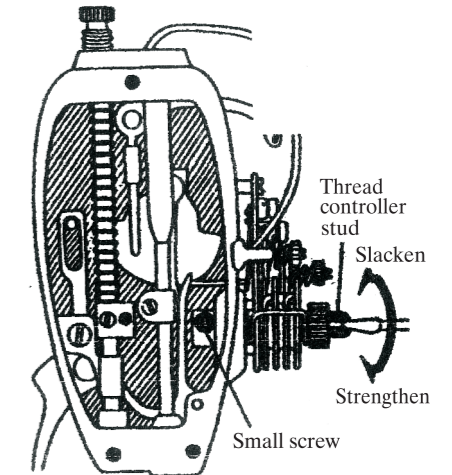

* Stitching Adjustment

3) Operating range of the thread take up spring.

- ◆ In order to obtain proper working condition, it is necessary to adjust the strength of the take up spring as well as change the operating range of the take-up spring.
- ◆ The operating range can be measured when the take-up lever is at the highest position, and when the upper thread is pulled, and the tension spring moves within the width of 8mm, it is considered as standard.
- In case of standard (general fabrics) materials.approx. 8mm(5/16")
- In case of light (small stitch length) materials, increase the operating range slightly.....approx. 8mm(5/16") or up
- In case of heavy (large stitch length) materials. decrease the operating range slightly.....approx. 8mm(5/16") or less

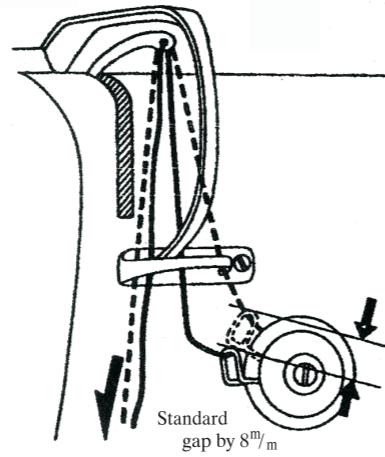

◆ How to adjustment (One Needle Type)

- (1) Lower the presser bar lifter.
- (2) Loosen the thread tension regulator set screw.
- (3) Fit the screw driver into the groove of the tension regulator stud; and turn the stud to the right to small the operating range.
- (4) Turn the stud to the left to large the operating rang.
- (5) After adjusted, tighten the screw.

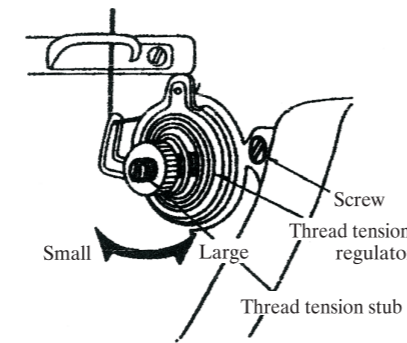

◆ How to adjust (Two Needle Type)

- (1) Loosen the thread controller set screw.
- (2) Fit the screw driver into the groove of the thread controller stud, and turn the stud to the right to small the operating range.
- (3) Turn the stud to the left to rarge the operating range.
- (4) After adjusted, tighten the screw.

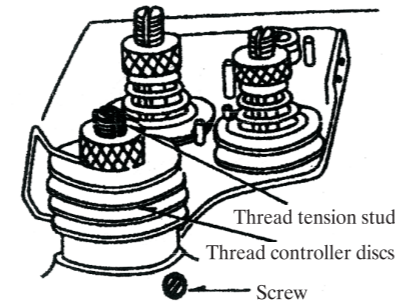

押棒機構部分

PRESSERFOOTMECHANISM

Fig. No.	Part No. 零件號碼	Code No. 料號	部 品 名	Name of Part	個/台 Amt.rep	
					810	820
907	81011907-000	MV 01E0 974	押棒組	Ollepr esser bar Assy	1	
908	81011908-000	MV 02E0 974	押棒組	Ollepr esser bar Assy		1
180	81011180-000	MV 01E0 973	押脚組	Ollepr eser Assy	1	
181	81011181-000	MV 02E0 973	押脚組	Ollepr esser Assy		1
182	81011182-000	MV 01A0 262	押 棒	resser bar Assy	1	
184	81011184-000	M9 3201 035	壓力調整螺絲	resser releasing thumd screw	1	1
185	81011185-000	M9 1508 001	螺絲	Etscrew(for Fig.182.183)	3	3
186	81011186-000	MF 20A0 265	押棒導塊	resser bar holder	1	1
187	81011187-000	MV 01A0 259	彈簧	resser spring	1	1
188	81011188-000	MV 91A9 510	連杆座	Knee lifer lever link	1	1
188-1	81011188-001		連杆	Knne lifter lever link	1	1
188-2	81011188-002		螺絲	Screw(for Fig.188)	1	1
189	81011189-000	M9 0505 063	連梢	Knee lifter lever pin	1	1
190	81011190-000	MF 60A0 725	脚弓大杆	Knee lifter lever	1	1
191	81011191-000	M9 1551 016	脚弓螺絲	Knee lifter lifting lever hinge screw	1	1
192	81011192-000	M9 1505 016	螺絲	Screw(for Fig.193)	1	1
193	81011193-000	MF 40A0 591	脚弓連接梢	Knee lifter lever joint	1	1
194	81011194-000	M9 1251 045	螺帽	Knee(for Fig.195)	1	1
195	81011195-000	MV 01A0 593	脚弓杆間連接棒	Knee lifter lever connection rod	1	1
196	81011196-000	MF 60A0 726	彈簧	Spring(for Fig.198)	1	1
197	81011197-000	M9 1104 003	螺絲	Screw(for Fig.198)	2	2
198	81011198-000	MF 60A0 594	脚弓杆連接支臂	Knee lifter lever connecting rod finder	1	1
199	81011199-000	MF 10A2 245	彈簧	Spring (for Fig.200)	1	1
200	81011200-000	NV 01A0 220	鬆緊杆	Tension releasing lever	1	1
201	81011201-000	M9 1102 033	螺絲	Setscrew(for Fig.200)	1	1
202	81011202-000	MF 10A0 267	押棒襯套	Presser bar dushing	1	1
203	81011203-000	M9 1102 001	螺絲	Set screw(for Fig.202)	1	1
204	81011204-000	MF 60A0 252	押棒升起	Presser bar lifter	1	1
205	81011205-000	M9 0704 063	押棒升起梢	Presser bar lifter pin	1	1

PRESSER FOOT MECHANISM

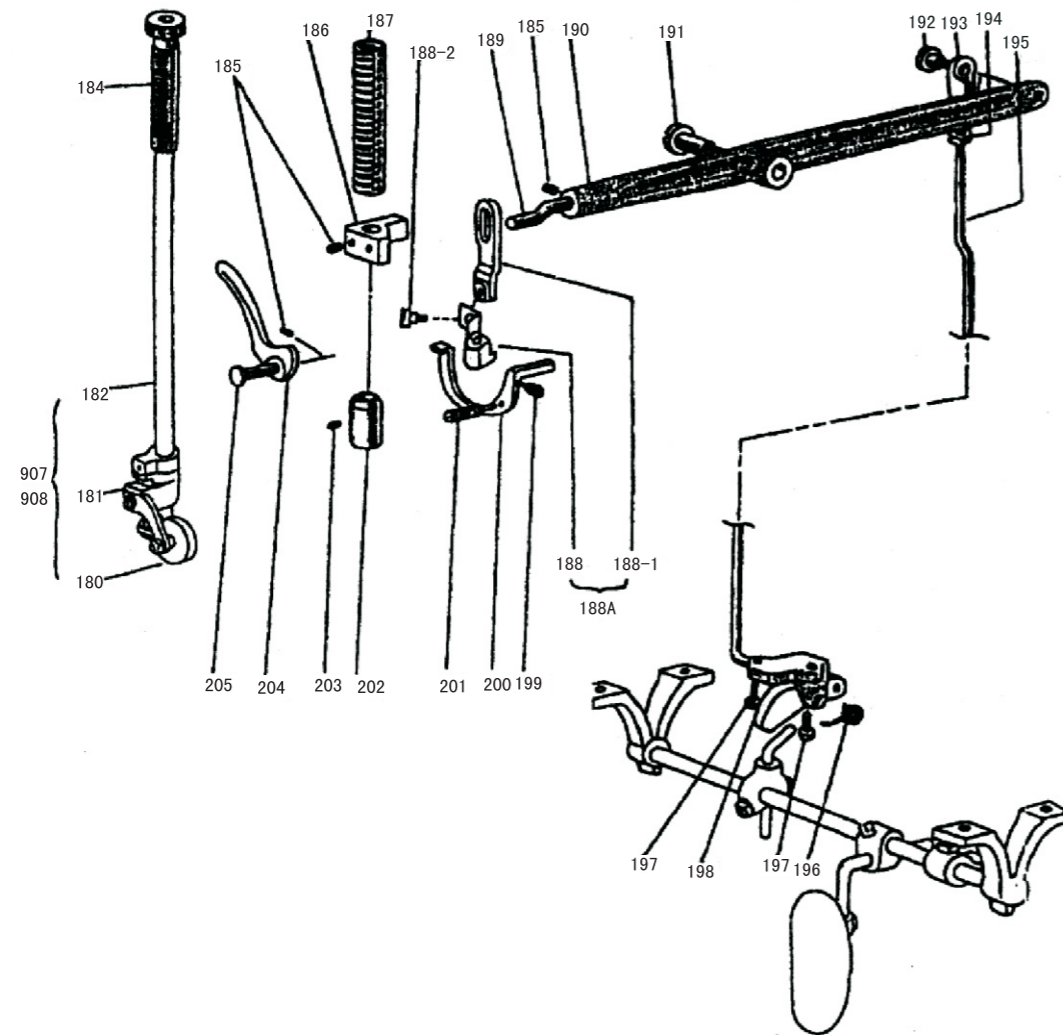

***Stitching adjustment**

■ **Tension of lower thread.**

There is virtually no need to adjust the lower thread tension, except for special kind of fabrics or thread, when slight adjustment will be necessary

- (1) Turn the balance wheel by hand, and stop when the thread take-up lever comes down to its lowest position.
- (2) Move the slide plate so that you find the thread tension screw of the hook base.
- (3) Fit the screw driver into the hole (A) of the hook shaft bracket as shown in Fig. Turn the tension screw to the right to strengthen the thread tension.
- (4) Turn the screw to the left to weaken the thread tension.

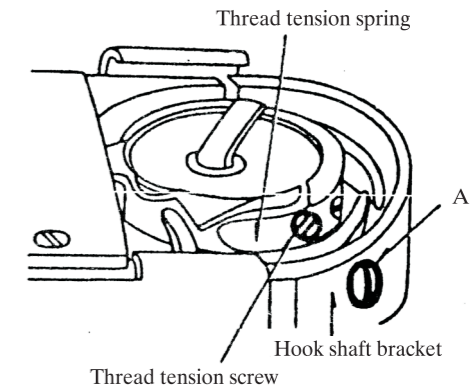

4. ADJUSTMENT OF FEED DOG HEIGHT AND PRESSURE OF PRESSER ON MATERIALS.

The feed dog height and pressure of presser on materials must be properly adjusted according to the materials to be sewn.

- ◆ In case of light materials: The material may be damaged if the feed dog is raised excessively or the pressure of presser on materials is too strong.
 - ◆ In case of heavy materials: It will not make uniform stitching if the feed dog is not raised properly or the pressure of presser is too weak.
- | | |
|---------------------------------|--------------------------------|
| In case of light materials..... | approx. 0.8mm in height |
| In case of general fabrics..... | approx. 1.0mm. in height |
| In case of heavy materials..... | approx. 1.2mm. in height |

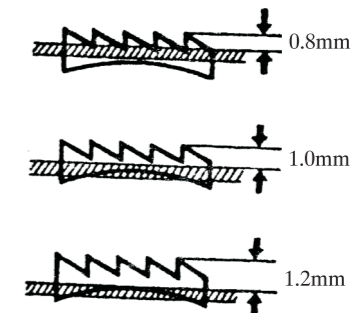

* The height of feed dog is measured when the feed dog is raised to its highest position from the surface of needle plate turning the balance wheel by hand.

1) Adjustment of feed dog height.

- (1) Lay down the machine bed toward the other side.
- (2) Remove the gear box.
- (3) Turn the balance wheel by hand and stop when the feed dog is raised to its highest position from the surface of needle plate.
- (4) Loosen the screw of feed lifting rock shaft crank.
- (5) Adjust the feed dog to the desired height moving the feed lifting rock shaft crank back and forth as per an arrow shown in Fig.
- (6) After adjusted, tighten the screw of feed lifting rock shaft.

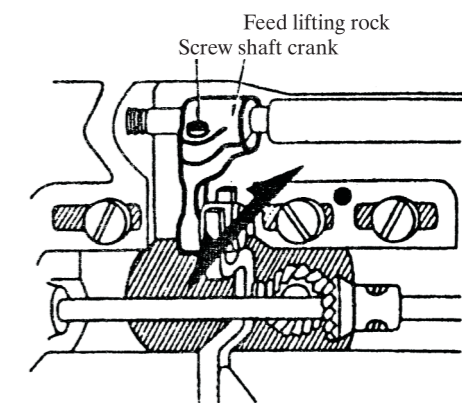

* Stitching Adjustment

2) Adjustment of pressure of presser foot.

- (1) Turn the presser regulating thumb screw to the right to strengthen the pressure of presser foot.
- (2) Turn the screw to the left to loosen the pressure of presser foot.

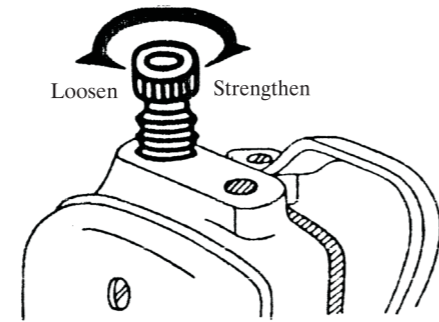

5. PROPER TIMING BETWEEN THE HOOK AND NEEDLE.

Place and adjust the hook in the condition described below in case of the thread gets entangled in the hook, or when its position is changed due to shock, or other causes, or when it is replaced with new a one.

1) How to remove the hook

- (1) Turn the balance wheel by hand and stop when the thread take up lever comes down to its lowest position.
- (2) Remove the slide plate, then take out the bobbin.
- (3) Remove the needle plate.
- (4) Remove the hook cover plate (front) (In case of two needle type, remove the hook cover plate(upper)both the front and back.)
- (5) Remove the hook opener screw, and then remove the opener.
- (6) Loosen the hook gib screw and remove the hook gib fixed in front of the hook body as shown in Fig.
- (7) Hold the latch lever up turning it slightly so that it can be taken out.
- (8) Remove the hook body center set screw so that it can be taken out.

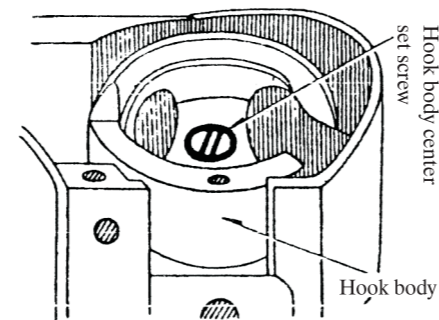
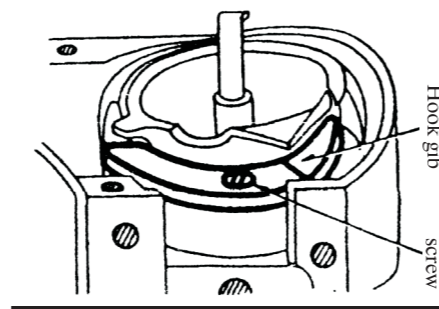
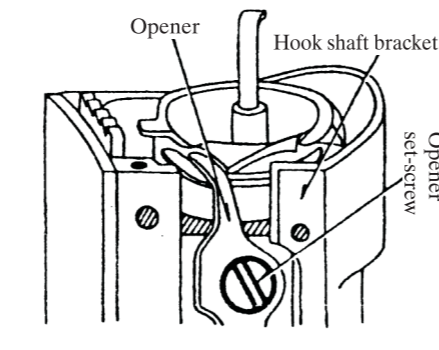

倒縫機構部分

STITCHREGULATORMECHANISM

Fig. No.	Part No. 零件號碼	Code No. 料號	部 品 名	Name of Part	個/台 Amt.rep	
					810	820
151	81009151-000		螺絲	Screw	1	1
152	81009152-000	M9 0905 063	梢	Set pin(for Fig.153)	1	1
153	81009153-000	MF 10A0 153	連杆	Feed connecting link	1	1
154	81009154-000	M9 1807 015	連杆軸	SET PIN(FOR Fig.153)	1	1
155	81009155-000	M9 1504 002	螺絲	Set screw(for Fig.156)	2	2
156	81009156-000	MV 01A0 152	進給調整	Feed regulator	1	1
157	81009157-000	M9 1513 001	螺絲	Set screw(for Fig.158)	3	3
158	81009158-000	MF 10A0 750	進給調節襯套	Feed Regulator bushing	1	1
159	81009159-000	M9 0902 063	梢	Set pin(for Fig.156)	1	1
160	81009160-000	MF 10A2 572	彈簧	Spring(for Fig.162)	1	1
161	81009161-000	MV 01A0 640	針距調整螺絲	Screw-bar for(MS-5510,5520)	1	1
162	81009162-002	MF 10A0 852	檔梢	Stopper pin(for Fig.163)	1	1
163	81009163-000	MF 11D0 631	針距調整盤	Stich length regulator dial	1	1
164	81009164-000	M9 1209 002	螺絲	Screw(for Fig.163)	1	1
165	81009165-000	M9 1207 003	螺絲	Screw(for Fig.167)	1	1
166	81009166-000	M9 1003 653	彈簧華司	Spring washer(for Fig.167)	1	1
167	81009167-000	MF10A0 632	倒縫杆	Reverse sewing lever	1	1
168	81009168-000	M9 1501 002	螺絲	Setscrew(for Fig.167)	2	2
169	81009169-000	MF 60A0 633	軸	Shaft(for Fig.167)	1	1
906	81009906-000	MF 1030 635	倒縫連杆組	Reverse sewing crank Assy	1	1
170	81009170-000	MF 60A0 634	倒縫連杆	Reverse sewing lever	1	1
171	81009171-000	M9 1501 007	螺絲	Set screw(for Fig.170)	1	1
172	81009172-000	MF 60A0 572	彈簧	Spring(for Fig.170)	1	1
173	81009173-000	M9 1110 002	螺絲	Screw(for Fig.174)	2	2
174	81009174-000	MV 01A0 708	固定板	Bracket(for Fig.172)	1	1
175	81009175-000	MV 01A0 738	拉升杆	Knee lifter rod	1	1

STITCH REGULATOR MECHANISM

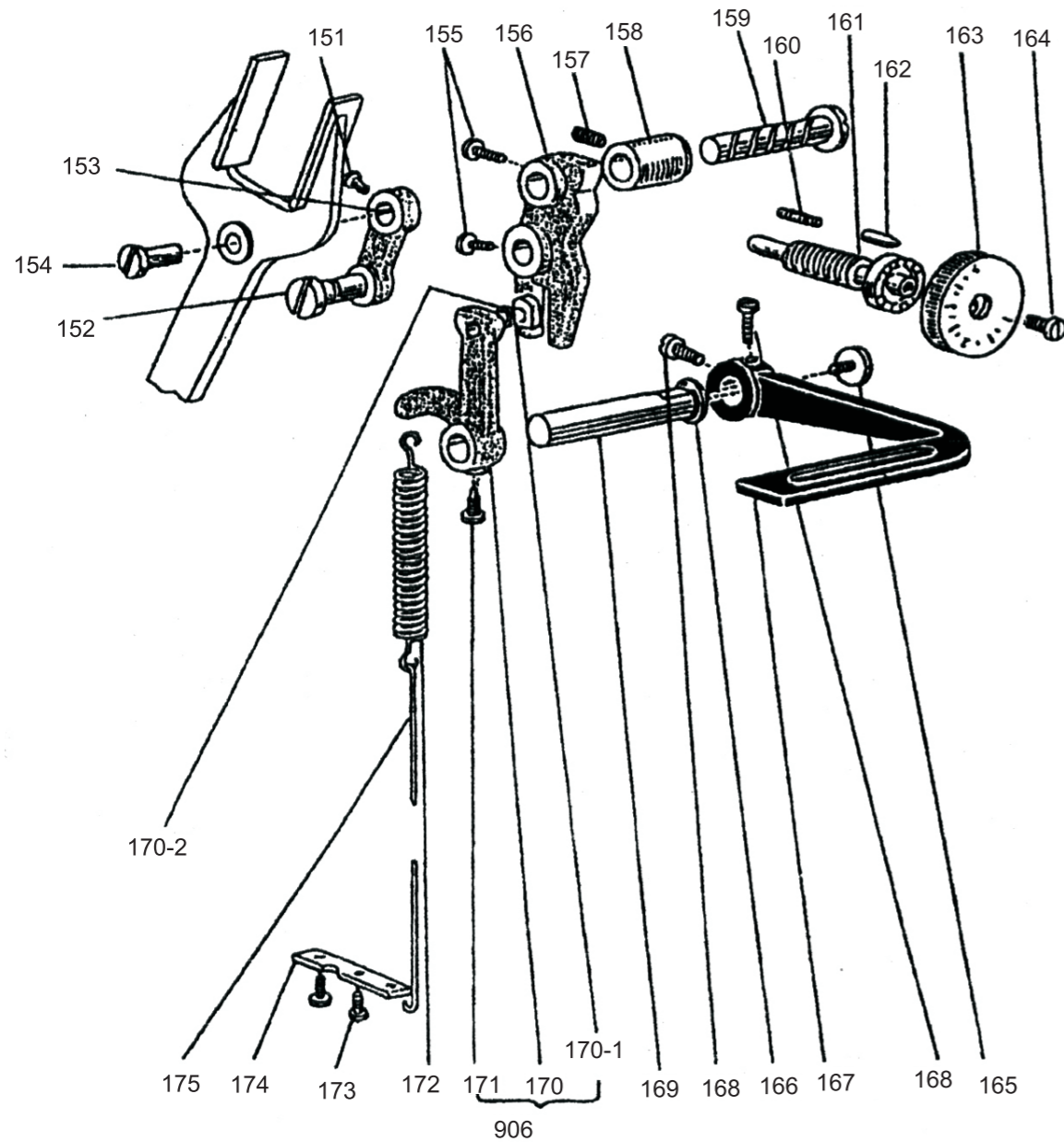

*** Stitching adjustment**

2) How to place the hook:

- (1) Place the hook in backward order from removing procedure.
- (2) When placing the hook body, remember to place it at the same position as it was taken out.
- (3) When inserting the hook base hold the hook base cap turning it to the left as shown in Fig. And fit the hook base brim into slot of the hook body on the inside of the other side.
- (4) When placing the needle plate, place the needle plate adjusting the hook base so that the tip of hook base fits into the hook finger of the needle plate as shown in Fig.

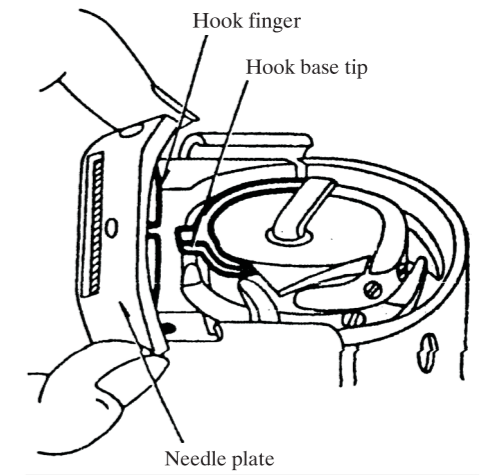
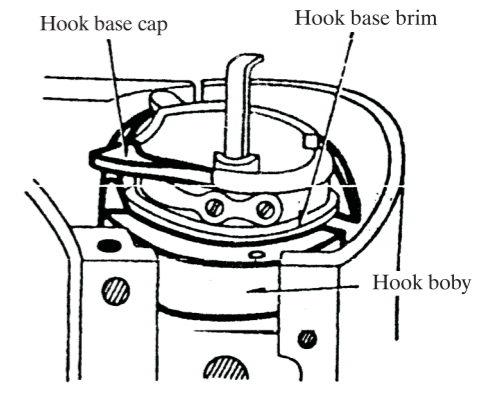

The position of the hook and needle:
As shown in the Fig. When the needle raised is 2.0mm from its lowest position of the needle, the hook and needle should be as follows.

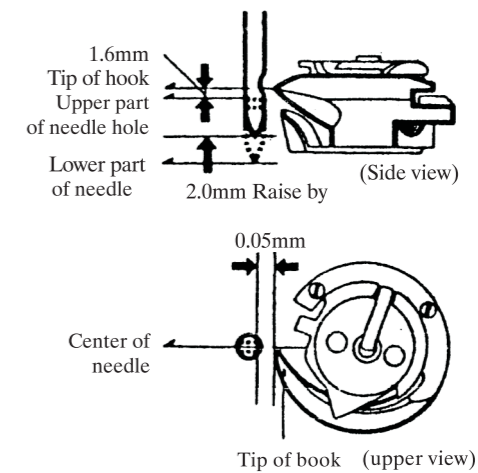

- ◆ Upper part of the needle hole.....
.....Lower by 1.6mm from the tip of hook.
- ◆ Tip of hook.....At center of needle.
- ◆ Gap between tip of hook and lateral face of needle..... by 0.05mm.

Adjustment of the relative position of the hook and needle can be done as follows:

* Move the roller foot to the left, remove the needle plate for easy adjustment.

* Stitching Adjustment

■ Adjustment of needle bar position.

Adjust the needle bar timing so that the gap between the tip of hook and the upper part of needle hole will be 1.6mm when the needle is raised by 2.0mm from its lowest position.

- (1) Raise the needle bar by 2.0mm from its lowest position turning the balance wheel by hand.
- (2) Loosen the needle bar connecting stud screw through a driver hole(lower)of the face plate.
- (3) Adjust moving the needle bar up and down so that the tip of hook comes at the position by 1.6mm from the upper part of needle hole.
- (4) After adjusting the needle bar position, tighten the needle bar connecting stud screw.

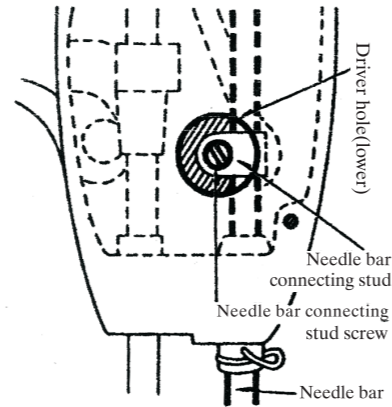

■ Adjustment of tip of hook

◆ Adjust so that the tip of hook comes to the center of needle.

- (1) Remove the needle plate and slide plate.
- (2) Lay down the machine head toward the other side.
- (3) Remove the gear box.
- (4) Loosen the two set screws of the hook shaft gears.
- (5) Turn the balance wheel by hand, and stop when the needle is raised 2.0mm from its lowest position.
- (6) Turn the hook by hand enabling the tip of hook to come to the center of needle.
- (7) After adjusting, tighten the two set screws of the hook shaft gears.
- (8) Place the gear box.

(In case of One Needle Type)

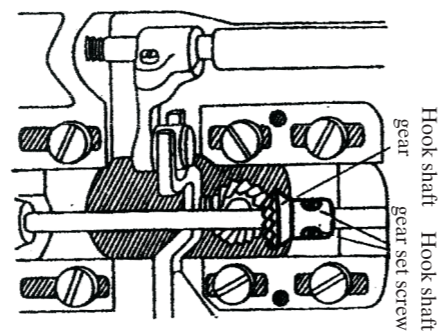

(In case of Two Needle Type)

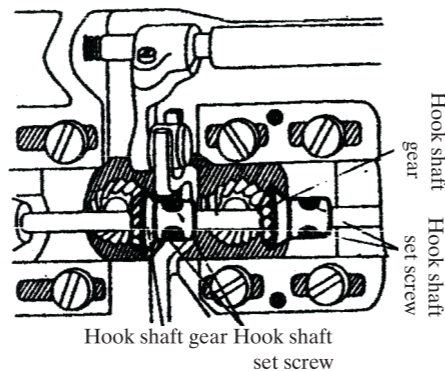

調器器部分

UPPER THREAD TENSION REGULATOR MECHANISM

Fig. No.	Part No. 零件號碼	Code No. 料號	部 品 名	Name of Part	個/台 Amt.rep	
					810	820
115	81007115-000	M9 1606 001	螺絲	Set screw(for Fig.116)	1	1
116	81007116-000	MV 01A0 331	斜齒輪(上軸)	Bevel gear(upper shaft)	1	1
117	81007117-000	MF 10A0 333	豎軸齒輪	Bevel gear(vertical shaft upper)	2	2
118	81007118-000	MF 60A3 740	羊毛氈電片	Felt	1	1
119	81007119-000	MQ 70A0 521	豎軸襯套(上)	Vertical shaft bushing(upper)	2	2
120-A	81007120-00A	MF 67B0 522	豎軸襯套(中)	Vertical shaft bushing(upper)	1	1
120-B	81007120-00B	MF 67B0 522	豎軸襯套(下)	Vertical shaft bushing	1	1
121	81007121-000	MQ 70A0 520	豎軸	Vertical shaft	1	1
122	81007122-000	MF 10A0 352	豎軸套環	Vertical shaft collar	1	1
123	81007123-000	M9 1508 001	螺絲	Set screw(for Fig.122)	1	1
124	81007124-000	MF 10A0 334	斜齒輪(豎軸)21T	Bevel gear(vertical shaft under)	1	
125	81007125-000	MF 10A0 332	斜齒輪(梭軸)18T	Bevel gear(hook shaft)		1
126	81007126-000	MV 01A0 230	上軸	Upper shaft	1	1
904	81007904-000	MV 01E0 280	凸輪進給組(毛毛組)	Feed cam Assy	1	1
127	81007127-000		凸輪進給	Feed cam	1	1
127-1	81007127-001		C型扣環	Ring	1	1
128	81007128-000	M9 1508 001	螺絲	Set screw(for Fig.127)	2	2
129	81007129-000		凸輪進給套圈	Feed cam ring	1	1
130	81007130-000	MF 60A1 740	油墊	Felt	2	2
131	81007131-000	MF 60A0 700	彈簧(S鈎)	Spring(for Fig.130)	2	2
132	81007132-000	M9 1516 001	螺絲	Set screw(for Fig.133)	1	1
133	81007133-000	MF 60A0 233	上襯套(右)	Upper shaft bushing(right)	1	1
134	81007134-000	M9 1520 002	螺絲	Set screw(for Fig.135)	2	2
135	81007135-000	MF 65B0 682	皮帶輪	Balance wheel	1	1
136	81007136-000	MN 65B0 682	螺絲	Screw(for Fig.135)	1	1
905	81007905-000	MV 01E0 384	連杆組	Crank rod Assy	1	1
137	81007137-000	M9 1203 002	螺絲	Screw(for Fig.139)	1	1
138	81007138-000	MG 30B0 740	油墊	Felt	1	1
139	81007139-000		連杆	Crank rod	1	1
140	81007140-000	MV 01A0 744	曲進連杆	Feed forked connection	1	1
141	81007141-000	M9 1803 036	連杆用螺絲	Crank rod taper screw(for	1	1
142	81007142-000	M9 1802 045	螺帽	Fig.139)	1	1
143	81007143-000	M9 2201 003	螺絲	Nut(for Fig.141)	1	1
				Screw		

UPPER SHAFT AND VERTICAL SHAFT MECHANISM

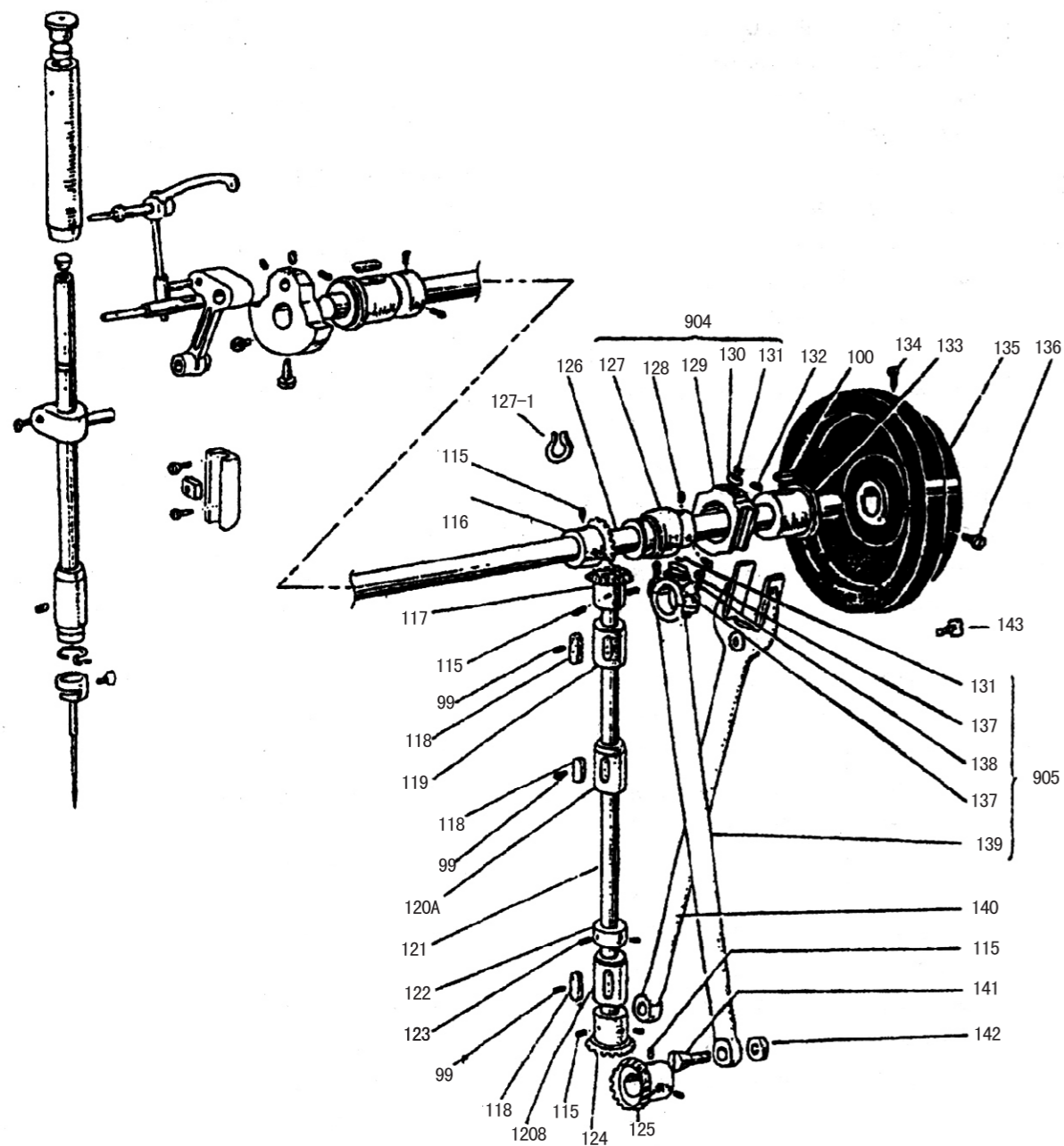

* Stitching adjustment

◆ Adjust that the gap between the tip of hook and lateral side of the needle to come to 0.05mm.

In case of 1-needle, there is virtually no need to adjust it. However, in case of 2-needle, it is necessary to adjust it when changing the needle gauge sizes.

- (1) Loosen the screws of the hook post cover Plate(front and back).
- (2) Lay down the machine head toward the other side.
- (3) Remove the gear box.
- (4) Loosen the hook shaft gear set screws.
- (5) Loosen the set screws of hook shaft bracket.
- (6) Turn the balance wheel by hand, and stop when the needle is raised by 2.0mm from its lowest position.
- (7) Turn the hook by hand and bring the tip of hook to the center of needle.
- (8) Move the hook shaft bracket to the right and left, so that the gap between the tip of hook and lateral side of needle is 0.05mm.
- (9) After adjusting, tighten the set screws of hook shaft gear and bracket.
- (10) Place the gear box.

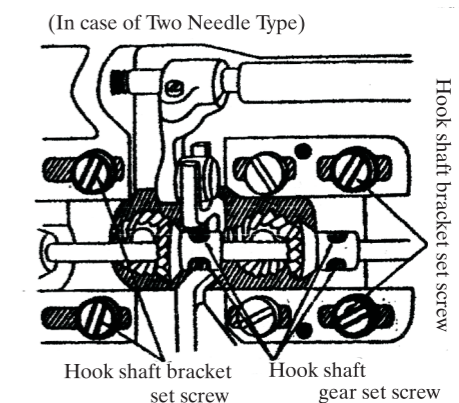
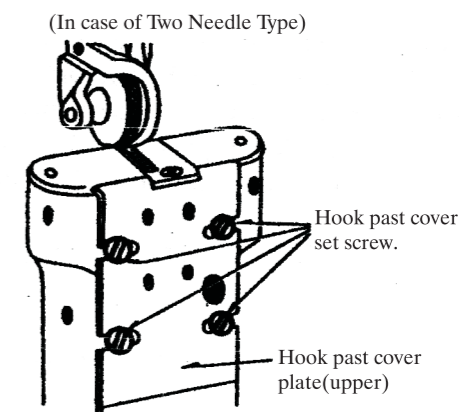

6. PROPER TIMING BETWEEN THE HOOK AND OPENER.

- (1) Remove the slide plate.
- (2) Turn the balance wheel by hand, and stop at the position where the opener and the needle plate are furthers point apart.
- (3) Check whether the gap between the part of hook base(A)and the opener is approx. 0.2mm as shown in Fig.
(There is a slight difference according to the thread to be used)

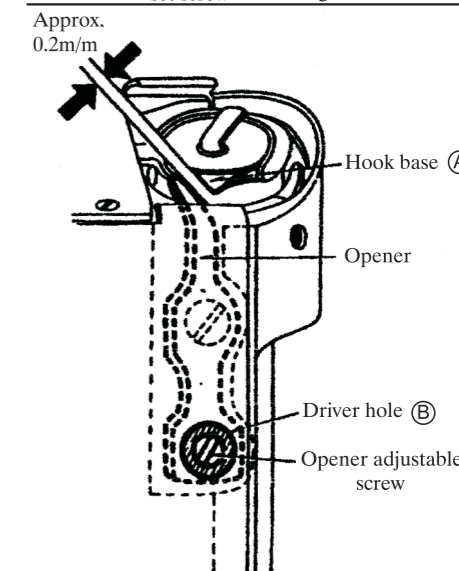

- (1) In case the gap is too wide or narrow, adjust it fitting the screw driver into a driver hole (B) of the hook shaft bracket, then loosen the opener adjustable screw and moving the opener to the right or left.
- (5) After adjustment, tighten the opener adjustable Screw.

* Stitching Adjustment

7. PROPER TIMING BETWEEN THE FEED DOG AND NEEDLE.

The proper timing of the feed dog and needle will be when the material is fed through and the needle tip reach to the needle plate surface, just at the moment the feed dog begins to sink downward through the needle plate surface as shown in Fig.

This adjustment is based on the Feed dog height is at 1.0mm.

- (1) Loosen the arm side cover thumb screw.
- (2) Move the side cover to the right, and open to upper side as shown in Fig.
- (3) Loosen the set 2-screws of the feed lifting cam.
- (4) While holding the feed lifting cam by hand, turn the balance wheel toward your side so that feeding device will be faster.
- (5) In order to slow the feeding device, turn the balance wheel toward the other side.
- (6) After adjustment, tighten the set screws of the feed lifting cam.

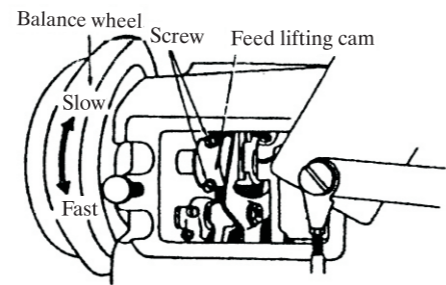
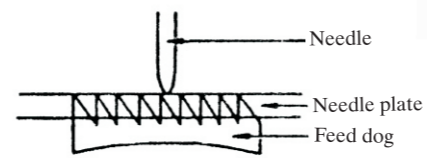

針棒部分

NEEDLE BAR AND TAKE-UP LEVER MECHANISM

Fig. No.	Part No. 零件號碼	Code No. 料號	部 品 名	Name of Part	個/台 Amt.rep	
					810	820
75	8100575-000	MF 60A0 742	橡膠蓋	Needle bar upper bushing cap	1	1
76	8100576-000	MF 10A2 740	羊毛氈墊片	Needle bar upper bushing cap felt	1	1
77	8100577-000	M9 1102 001	螺絲	Set screw(for Fig. 78)	2	2
78	8100578-000	MF 60A0 663	針棒套筒(筒)	Needle bar bushing(upper)	1	1
79	8100579-000	MF 10E2 148	油心	Oil wick	2	2
80	8100580-000	MN 10A1 500	塑膠塞	Plastic plug(for Fig. 84.85)	1	1
81	8100581-000	MN 10A1 740	油墊	Felt	1	1
82	8100582-000	MF 10A0 665	針棒拉基	Needle bar connecting stud	1	1
83	8100583-000	M9 0909 003	螺絲	Screw(for Fig. 82)	1	1
84	8100584-000	MV 01A0 660	單針針棒	Needle bar	1	
85	8100585-000	MV 02A0 660	雙針針棒	Needle bar		1
86	8100586-000	MF 10A0 664	針棒套筒(下)	Needle bar bushing(under)	1	1
87	8100587-000	MF 10A1 181	單針用過綫	Thread guide	1	
88	8100588-000	M9 0802 003	針榴螺絲	Needle clamp screw	1	
89	8100589-000	MF 10A2 181	單針針棒過綫	Thread guide	1	
90	8100590-000		針	Needle	1	2
91	8100591-000	M9 1516 001	螺絲	Set screw(for Fig. 92)	1	1
92	8100592-000	MN 10A0 587	天秤軸	Take-up lever support stud	1	1
93	8100593-000	MP 00B0 582	單針天秤	Take-up lever	1	
94	8100594-000	MV 02A0 582	雙針天秤	Takw-up lever		1
95	8100595-000	MN 10A0 588	天秤滑棒	Take-up slide block	1	1
96	8100596-000	MN 10A0 387	連杆梢	Crank pin	1	1
97	8100597-000	MQ 50A0 661	針棒連杆	Needle bar connecting crank rod	1	1
98	8100598-000	M9 1601 001	螺絲組	Set screw(for Fig.104)	1	1
99	8100599-000	M9 1513 001	羊毛氈墊片	Set screw(for Fig.103)	3	3
100	81005100-000	MF 60A2 740	油墊	Feit	2	2
101	81005101-000	M9 1606 001	螺絲組	Set screw(for Fig.102)	2	2
102	81005102-000	MF 20A2 352	上軸組	Upper shaft collar	1	1
103	81005103-000	MQ 50A0 232	上軸襯(左)	Upper shaft bushing(left)	1	1
104	81005104-000	MV 01A0 383	曲柄	Crank	1	1
105	81005105-000	MF 20A2 352	螺絲	Set screw(for Fig.104)	1	1
106	81005106-000	M9 1801 002	螺絲	Set screw(for Fig.104)	1	1
107	81005107-000	MF 10A0 662	滑塊槽	Needle bar connecting link guide	1	1
108	81005108-000	MF 10A0 325	針棒導塊	Square block(for Fig.82)	1	1
109	81005109-000	M9 1110 002	螺絲	Screw(for Fig.107)	2	2

NEEDLE BAR AND TAKE-UP LEVER MECHANISM

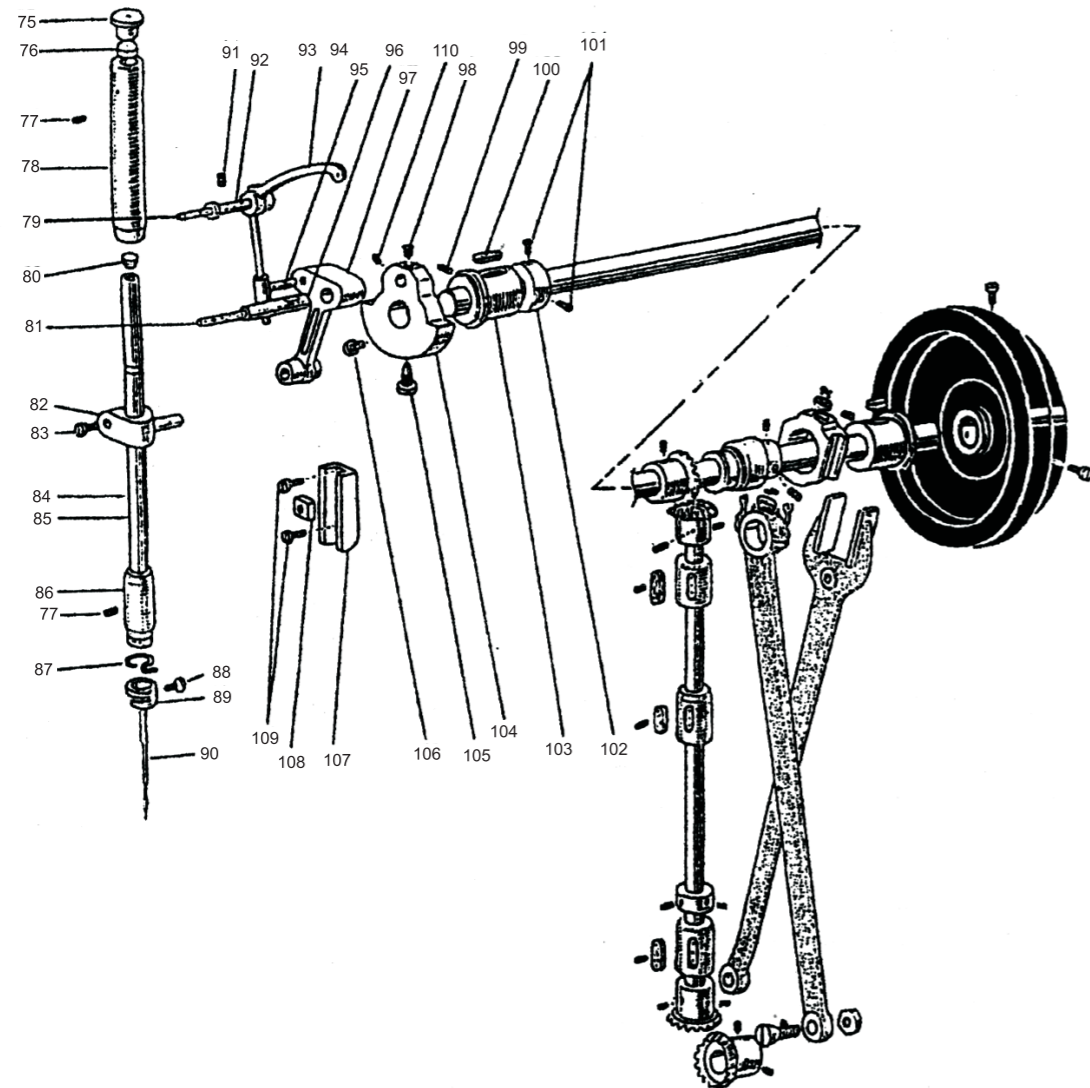

V. CLEANING AND LUBRICATION.

1. Cleaning.

The teeth of feed dog, hook, upper thread tension regulator discs, and thread controller discs are often covered by dust and lint causing improper operation and uneven stitching. Therefore, clean as often as necessary.

2. Lubrication.

Lubrication is one of the most important phases of the machine maintenance. With improper lubrication, excess abrasion of machine parts will cause to shorten the life of the machine. Therefore, lubricate in the order as follows:

1) The number of times for lubrication.

- (1) Usual working..... at 2-3 times per week.
- (2) Continuous working, every day...once each day

2) Volume of lubrication:

- Places ○ marked...approx. 5cc or more
- Place ▨ marked...approx. 5-6 drops
- Place ◡ marked...approx. 1-2 drops

3) Places where to lubricate.

Lubricate the places where arrow is shown in Fig. (inside of face plate, arm bed)

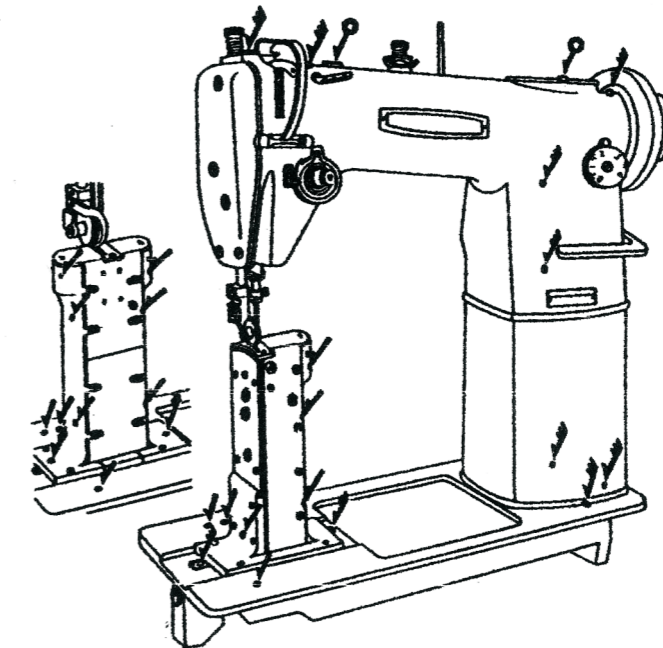

* Cleaning and Lubrication

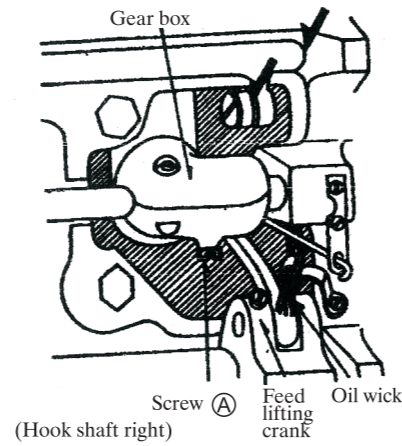
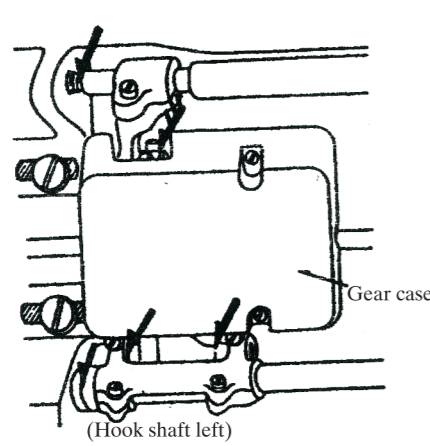

* Since the oil wick connected with the feed lifting crank for the right side of hook shaft is worked to flow oils, penetrate oil fully before working (if the oil wick is not penetrated with oil, it has no effect to flow oil).

3. GREASE.

- 1) Remove the oil hole screws(A)&(B), of the gear box fixed to arm and hook shaft, then grease into the holes periodically.
- 2) Remove the gear case of the left side of hook shaft, then also grease into the gears sufficiently

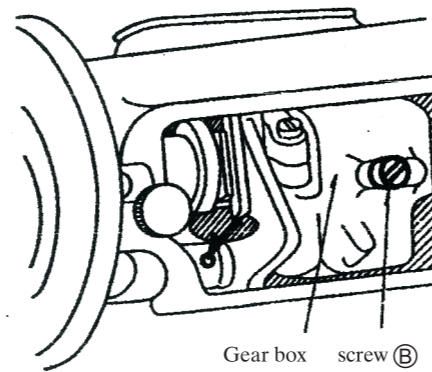
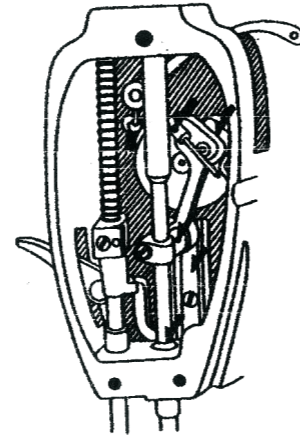

調節器部分

UPPER THREAD TENSION REGULATOR MECHANISM

個/台
Amt.rep

Fig. No.	Part No. 零件號碼	Code No. 料號	部 品 名	Neme of Part	810	820
902	81003902-000	MV 01E0 210	沙拉組(單針)	Thread tension regulator Assy	1	
903	81003903-	MV 0230 210	沙拉組(雙針)	Thread tension regulator Assy		1
1	000		螺帽	Nut	2	2
2	8100301-000		過綫盤組	Spring Guide Assy	1	2
3	8100302-001		調整彈簧	Tensin Spring	1	2
4	8100303-000		吊綫彈簧	Thread Take-up Spring	1	1
5	8100304-000		壓綫盤	Tension Disc	2	4
6	8100305-000		調整螺絲杆	Thread Tension Stud	1	1
7	8100306-000		螺絲	Screw	1	1
8	8100307-000		彈簧座	Thread Tension Regulator Bushing	1	1
9	8100308-000		鬆綫梢	Tension Releas Pin	1	1
10	8100309-000		鬆綫梢	Tension Releas Pin	1	1
11	8100310-000		彈簧板	Tension Releas Plate	1	1
12	8100311-000		螺絲	Screw	2	2
13	8100312-000		壓板彈簧	Tension Release Spring	1	1
14	8100313-000		螺帽	Nut	1	1
15	8100314-000		上綫壓力板	Upper Thread Tension Plate	1	1
16	8100315-000		調整螺絲杆	Thread Tension Stud	1	2
17	8100316-000		過綫孔臺	Thread Guide Bracket	1	2
18	8100317-000		過綫孔圓盤	Thread Guide Disc	1	2
19	8100318-000		道綫彈簧	Thread Guide Spring	1	2
20	8100319-000		過綫孔內蓋	Thread Guide Cap	1	2
21	8100320-000		螺絲	Screw	1	2
22	8100321-000		綫調整壓盤	Tension disc Washer	1	2
23	8100322-000		螺絲	Screw	1	1
25	8100323-000		鬆綫梢	Tension Releasinh Pin	1	1
26	8100325-000		襯套環	Bushing	1	1
27	8100326-000		螺絲	Screw	1	1
28	8100327-000		螺絲	Screw	1	
35	8100328-000	M9 1604 046	沙拉調節螺帽	Thread tension regulating thumb	1	
36	8100335-000	MF 10A0 245	沙拉彈簧	nut	1	
37	8100336-000	MF 10A0 556	沙拉片	Thread tension spring	1	
38	8100337-000	MV 01A0 802	沙拉擋片	Thread tension releasing disc	1	
39	8100338-000	MV 01A0 558	沙拉墊片	Tension regulator stop plate	1	
40	8100339-000	MF 10A0 555	沙拉片	Tension regulator bracket	2	
41	8100340-000	MV 01A0 553	沙拉螺柱	Tension disc	1	
42	8100341-000	MV 01A0 187	沙拉拉起彈簧	Thread tension stud	1	
43	8100342-000	M9 0212 060	沙拉鬆梢	Thread take-up spring	1	
44	8100343-000	MV 01A0 709	沙拉調整襯片	Thread tension releasing pin	1	

零 配 件 图

UPPER THREAD TENSION REGULATOR MECHANISM

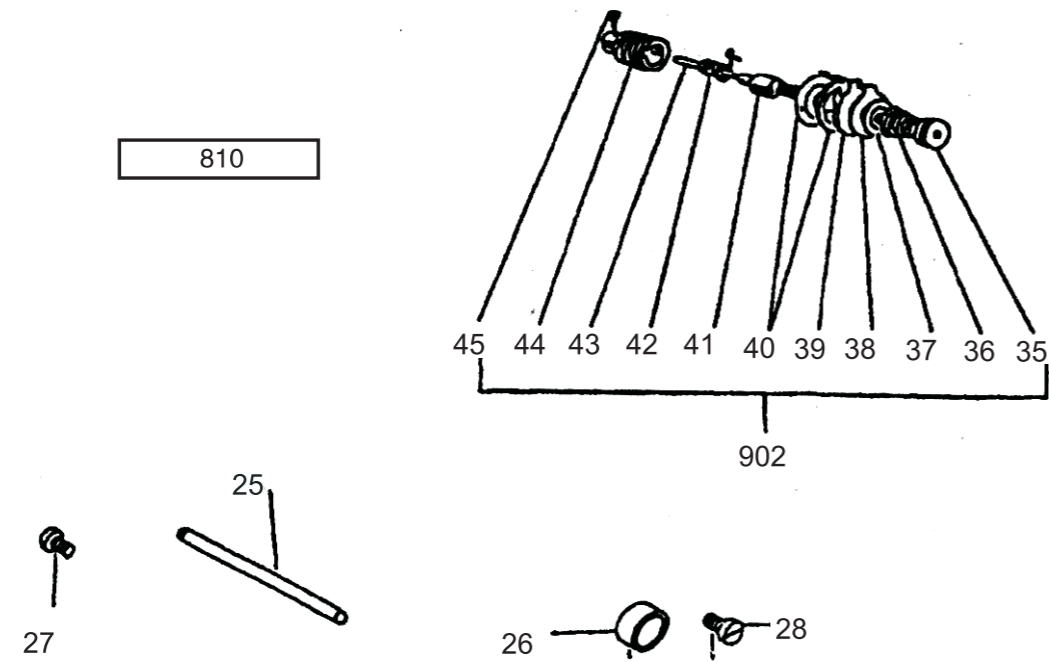

1、形本体部份 ARM BED AND ITS ACCESSORIES.....	26
2、调节器部份 UPPER THREAD TENSION REGULATIOR MECHANISM	28
3、针棒部分 NEEDLE BAR AND TAKE-UP LEVER MECHANISM.....	30
4、上轴、竖轴部份 UPPER SHAFT AND VERTICAL SHAFT MECHANISM	32
5、倒缝机构部份 STITCH REGULATOR MECHANISM.....	34
6、押棒机构部份 PRESSER FOOT MECHANISM.....	36
7、上轴、上下轴部份 ROTATING HOOK SHAFT AND FEED LIFTING ROCK MECHANISM	38
8、梭头机构部份 HOOK MECHANISM.....	40
9、给油机构部份 OIL LUBRICATION MECHANISM.....	44
10、零件部份 CAUGE PARTS.....	46
11、附属品 ACCESSORIES.....	48
12、特别配件组 SPECIAL PARTS.....	50

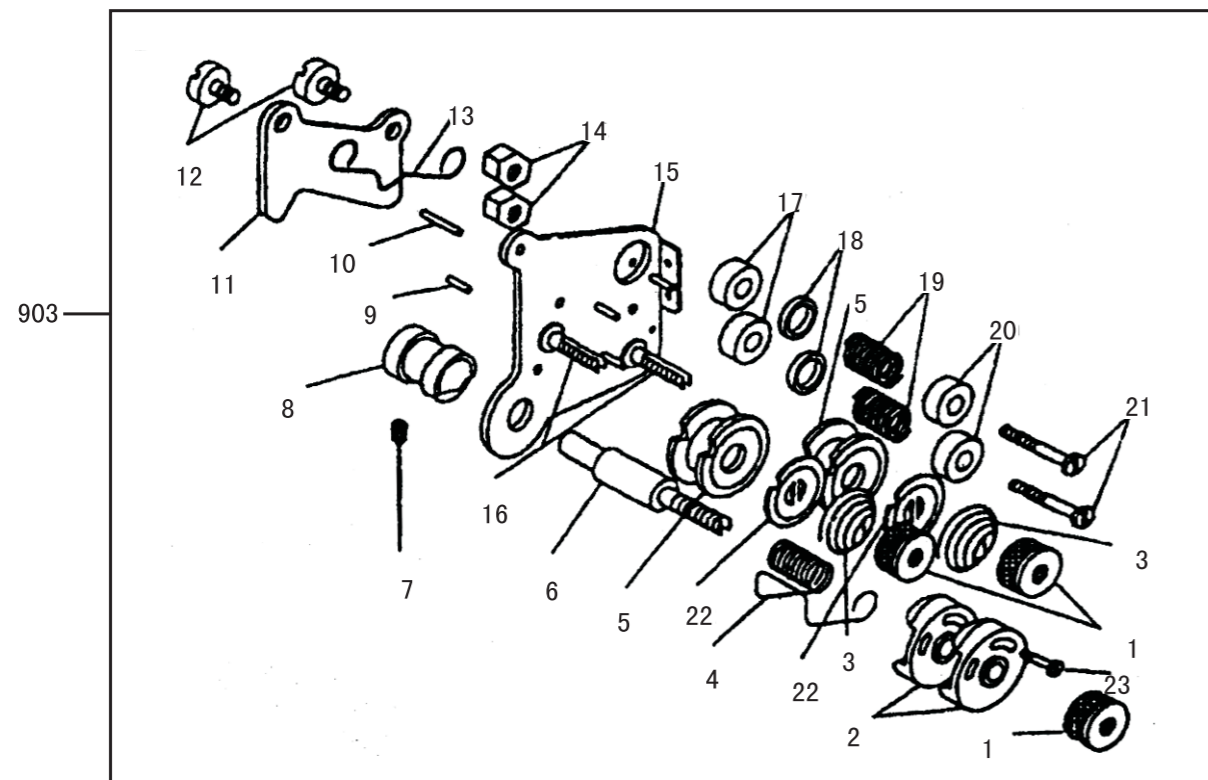

本體部分

ARM BED AND ITS ACCESSORIES

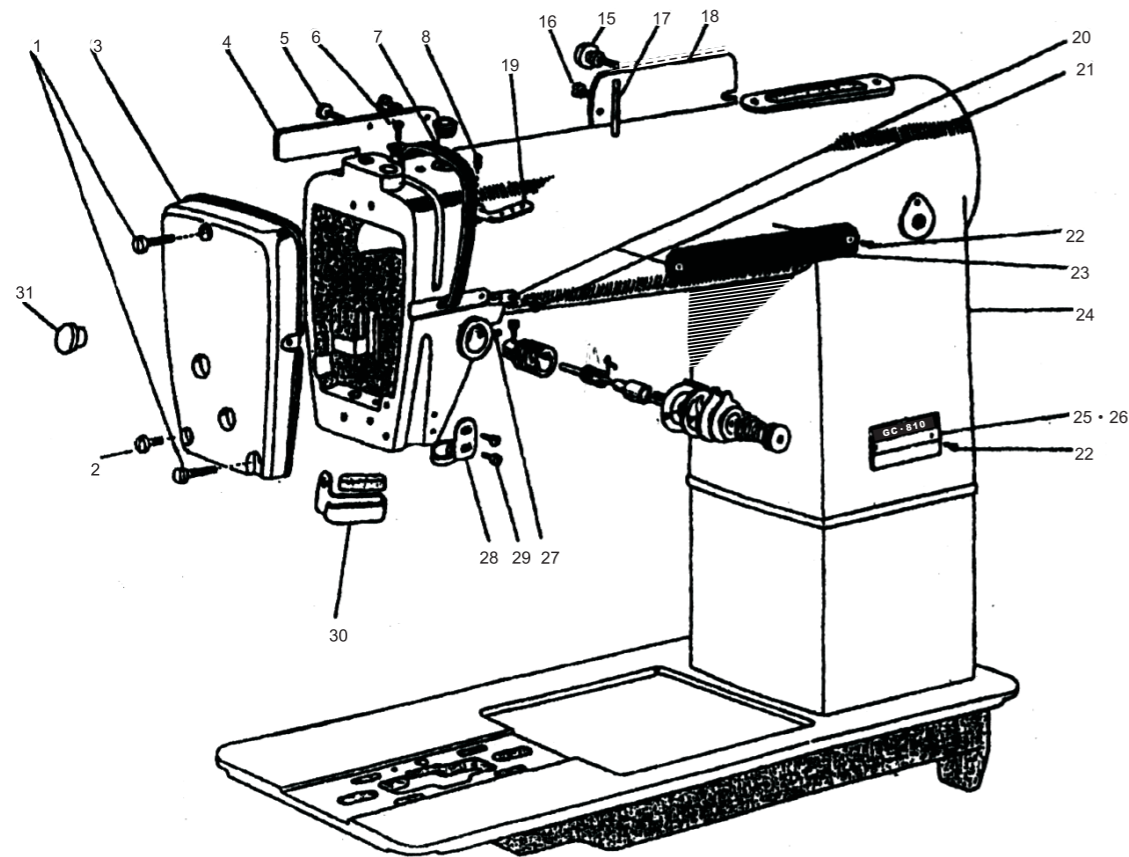

本體部分
ARM BED AND ACCESSORIES

Fig. No.	Part No. 零件號碼	Code No. 料號	部 品 名	Neme of Part	個/台 Amt.rep	
					810	820
1	8100101-000	M9 1101 004	螺絲	Screw(for Fig.3)	3	3
2	8100102-000	M9 1108 002	螺絲	Screw(for Fig.3)	1	1
3	8100103-000	MF 10A0 830	面板	Face plate	1	1
	8100103-001	MF 10A0 830	面板	Face Plate For MS-5510	1	1
4	8100104-000	MF 60A0 326	防沙板(小)	Side cover	1	1
5	8100105-000	M9 0915 003	螺絲	Screw(for Fig.4)	1	1
6	8100106-000	M9 1107 002	螺絲	Screw(for Fig.7)	1	1
7	8100107-000	MQ 50A0 584	天秤蓋	Thread take-up cover	1	1
8	8100108-000	M9 1108 001	螺絲	Set screw(for Fig.19)	1	
15	8100115-000	M9 0901 035	螺絲	Screw(for Fig.18)	1	1
16	8100116-000	M9 0908 015	螺絲	Screw(for Fig.18)	1	1
17	8100117-000	MF 10A0 186	過綫梢	Spool.pin	1	2
18	8100118-000	MF 60A0 880	防沙板(大)	Arm side cover	1	1
19	8100119-000	MF 10A0 180	三孔過綫杆	3 hole thread retainer	1	
20	8100120-000	MV 01A0 181	過綫杆	Thread guide(arm)	1	1
21	8100121-000	M9 0904 011	螺絲	Screw(for Fig.20)	1	1
22	8100122-000	M9 5001 062	牌釘	Pin(for Fig.23)	1	4
23	8100123-000		名牌	Name plate	1	2
24	8100124-000		本體	Arm and bed	1	1
25	8100125-000		型號牌	Model plate	1	
26	8100126-000		型號牌	Model plade		1
27	8100127-000	M9 1508 001	螺絲	Set screw(for Fig.902)		1
28	8100128-000	MQ 50A0 181	過綫杆(下臂)	Thred guide(under arm)	1	1
29	8100129-000	M9 1110 002	螺絲	Screw(for Fig.28)	1	1
30	8100130-000	MV 11E0 181	過綫	Thread guide		1
31	8100131-000	M9 1180 080	油塞	Rubber cork	2	2