

Cupboard - Armoire - Armario

IMPORTANT!-IMPORTANT!-IMPORTANTE!

Please provide Control No. to ensure replacement parts properly fit unit on hand.
Fournir N° de contrôle pour assurer que les pièces de rechange s'adaptent correctement à l'unité en question.

Favor de proporcionar el numero de control para garantizar que las piezas de reemplazo ajuste correctame su producto.

Control No.
N° de contrôle
de control

Name - Nom - Nombre

Address - Adresse - Dirección

City/State/Zip - Ville/Province/Code postal - Ciudad/Estado/Zona Postal

Phone - Téléphone - Teléfono

Email

“Check-list/Part Replacement request” - « Liste de contrôle/Demande de remplacement de pièce »

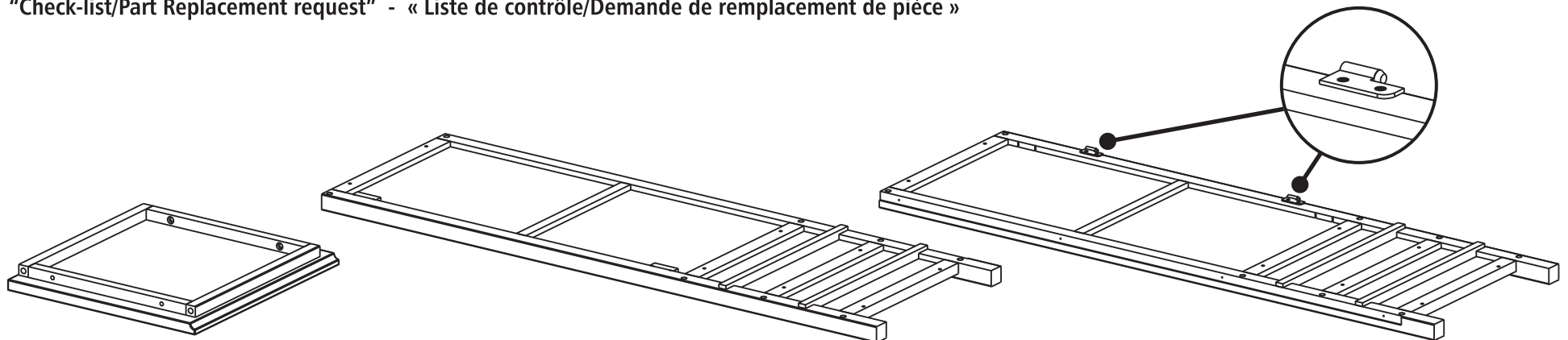

A	Top Panel Panneau supérieur Tapa		
Quantity Quantité Cantidad	1	Missing Manquant Ausente	

B	Left Panel Panneau gauche Panel izquierdo		
Quantity Quantité Cantidad	1	Missing Manquant Ausente	

C	Right Panel Panneau droit Panel derecho		
Quantity Quantité Cantidad	1	Missing Manquant Ausente	

Cupboard - Armoire - Armario

IMPORTANT!-IMPORTANT!-IMPORTANTE!

Please provide Control No. to ensure replacement parts properly fit unit on hand.
 Fournir N° de contrôle pour assurer que les pièces de rechange s'adaptent correctement à l'unité en question.
 Favor de proporcionar el numero de control para garantizar que las piezas de reemplazo ajuste correctame su producto.

**Control No.
 N° de contrôle
 # de control**

Name - Nom - Nombre

Address - Adresse - Dirección

City/State/Zip - Ville/Province/Code postal - Ciudad/Estado/Zona Postal

Phone - Téléphone - Teléfono

Email

Reason of replacement - Raison de remplacement - Razón del reemplazo:

“Check-list/Part Replacement request” - « Liste de contrôle/Demande de remplacement de pièce »

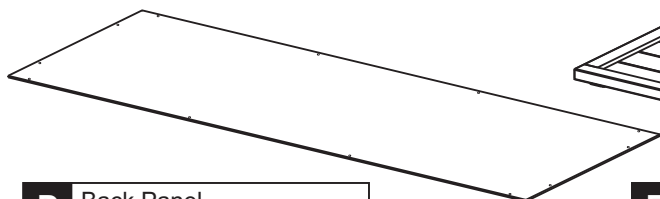

D	Back Panel Panneau arrière Panel trasero	Quantity Quantité Cantidad	1	Missing Manquant Ausente	
----------	--	----------------------------------	---	--------------------------------	--

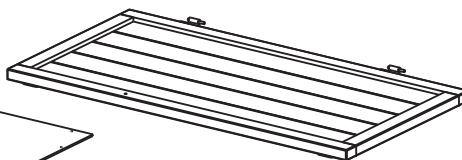

E	Door Porte Puerta	Quantity Quantité Cantidad	1	Missing Manquant Ausente	
----------	-------------------------	----------------------------------	---	--------------------------------	--

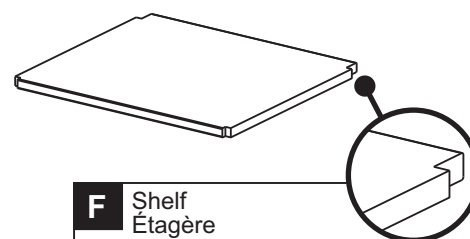

F	Shelf Étagère Repisa	Quantity Quantité Cantidad	1	Missing Manquant Ausente	
----------	----------------------------	----------------------------------	---	--------------------------------	--

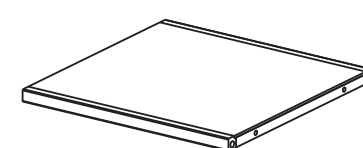

G	Middle Panel Panneau milieu Panel medio	Quantity Quantité Cantidad	2	Missing Manquant Ausente	
----------	---	----------------------------------	---	--------------------------------	--

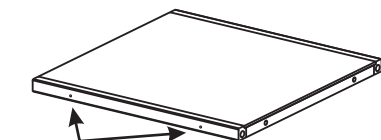

Screw Holes
Trous pour les vis
Agujeros para tornillos

H	Bottom Panel Panneau inférieur Panel de abajo	Quantity Quantité Cantidad	1	Missing Manquant Ausente	
----------	---	----------------------------------	---	--------------------------------	--

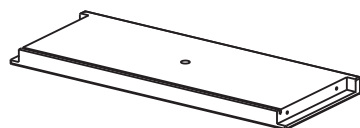

I	Front Panel (Drawer) Panneau avant (tiroir) Panel de enfrente (cajon)	Quantity Quantité Cantidad	2	Missing Manquant Ausente	
----------	--	----------------------------------	---	--------------------------------	--



J	Side Panel (Drawer) Panneau latéraux (tiroir) Panel Latéral (cajon)	Quantity Quantité Cantidad	4	Missing Manquant Ausente	
----------	--	----------------------------------	---	--------------------------------	--

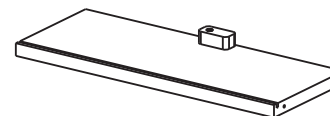

K	Back Panel (Drawer) Panneau arrière (tiroir) Panel de atrás (cajon)	Quantity Quantité Cantidad	2	Missing Manquant Ausente	
----------	--	----------------------------------	---	--------------------------------	--

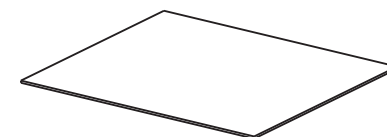

L	Bottom Board (Drawer) Conseil inférieur (tiroir) Base de abajo (cajon)	Quantity Quantité Cantidad	2	Missing Manquant Ausente	
----------	---	----------------------------------	---	--------------------------------	--

Cupboard - Armoire - Armario

IMPORTANT!-IMPORTANT!-IMPORTANTE!

Please provide Control No. to ensure replacement parts properly fit unit on hand.
Fournir N° de contrôle pour assurer que les pièces de rechange s'adaptent correctement à l'unité en question.

Favor de proporcionar el numero de control para garantizar que las piezas de reemplazo ajuste correctame su producto.

Control No.
N° de contrôle
de control

Name - Nom - Nombre

Address - Adresse - Dirección

City/State/Zip - Ville/Province/Code postal - Ciudad/Estado/Zona Postal

Phone - Téléphone - Teléfono

Email

Reason of replacement - Raison de remplacement - Razón del reemplazo:

"Check-list/Part Replacement request" - « Liste de contrôle/Demande de remplacement de pièce »



M	Knob Bouton Perilla			
Quantity Quantité Cantidad	3	Missing Manquant Ausente		

For Knob
Pour bouton
Para perilla

N	Bolt* Cheville* Tornillo de metal*			
Quantity Quantité Cantidad	3	Missing Manquant Ausente		

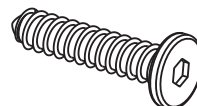

O	Wood Screw Vis à bois Tornillo para madera			
Quantity Quantité Cantidad	16	Missing Manquant Ausente		

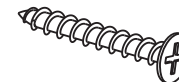

P	Screw* (Phillips) Vis* (Phillips) Tornillo* (Phillips)			
Quantity Quantité Cantidad	16	Missing Manquant Ausente		



Q	Small Screw* (Phillips) Petite vis* (Phillips) Tornillo Pequeño* (Phillips)			
Quantity Quantité Cantidad	16	Missing Manquant Ausente		

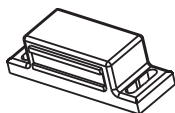

R	Magnet Latch Loquet à aimant Pasador Magnético			
Quantity Quantité Cantidad	2	Missing Manquant Ausente		



S	Wood Dowel Goujon en bois Clavija de madera			
Quantity Quantité Cantidad	16	Missing Manquant Ausente		



	Hex Wrench Clé Hexagonale Llave Hexagonal			
Quantity Quantité Cantidad	1	Missing Manquant Ausente		

Care instructions:

To clean, wipe with wet cloth and dry thoroughly. Use mild soap if necessary. Avoid use of commercial waxes or polishes or abrasive cleaning materials.

Instructions d'entretien:

Pour nettoyer, essuyez avec un linge humide et séchez à fond. Utilisez un savon doux au besoin. Évitez d'utiliser des cires ou produits à polir de type commercial ou des matériaux de nettoyage abrasifs.

Instrucciones para el cuidado:

Para limpiar, frótelo con algo húmedo y séquelo bien. Use un jabón suave si es necesario. Evite el uso de ceras o pulidores comerciales o materiales abrasivos.

* Screw Driver is required and not included in the package.

* Un tournevis est nécessaire mais n'est pas inclus avec cet ensemble.

* Se requiere desarmador de cruz y no viene incluido.

Assembly Instructions - Instructions d'assemblage - Instrucciones de ensamblaje

1

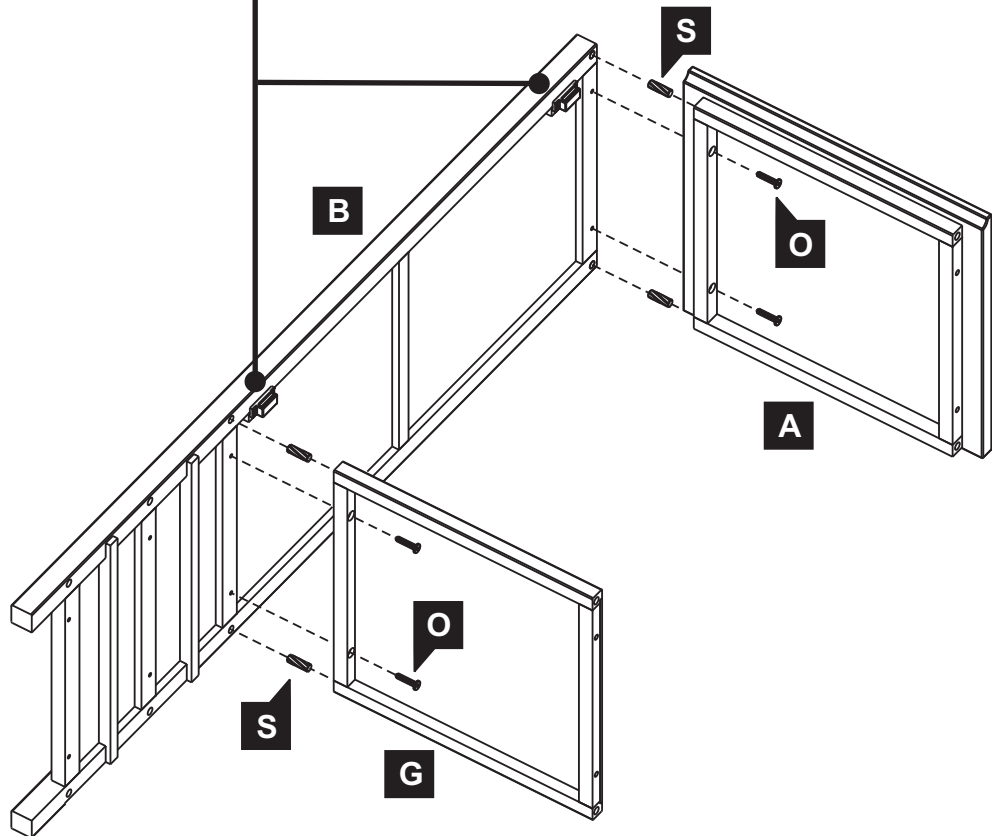
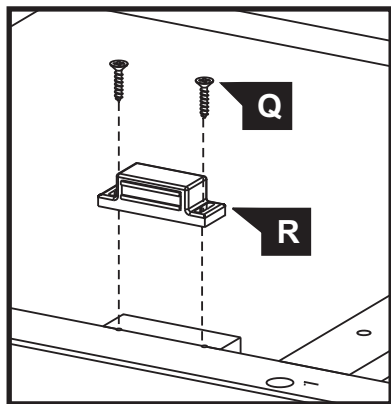

2

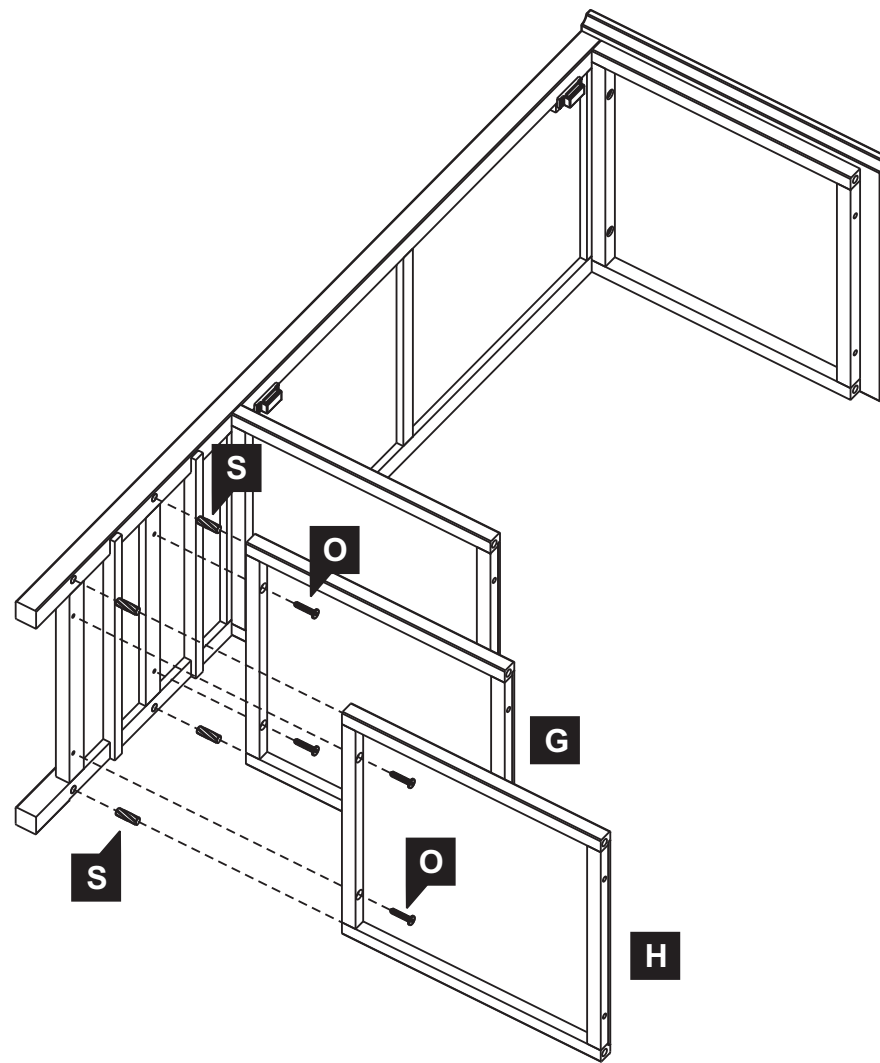

ASSEMBLY
ASSEMBLAGE
ENSAMBLAJE
TWO PERSONS
DEUX PERSONNES
DOS PERSONAS

3

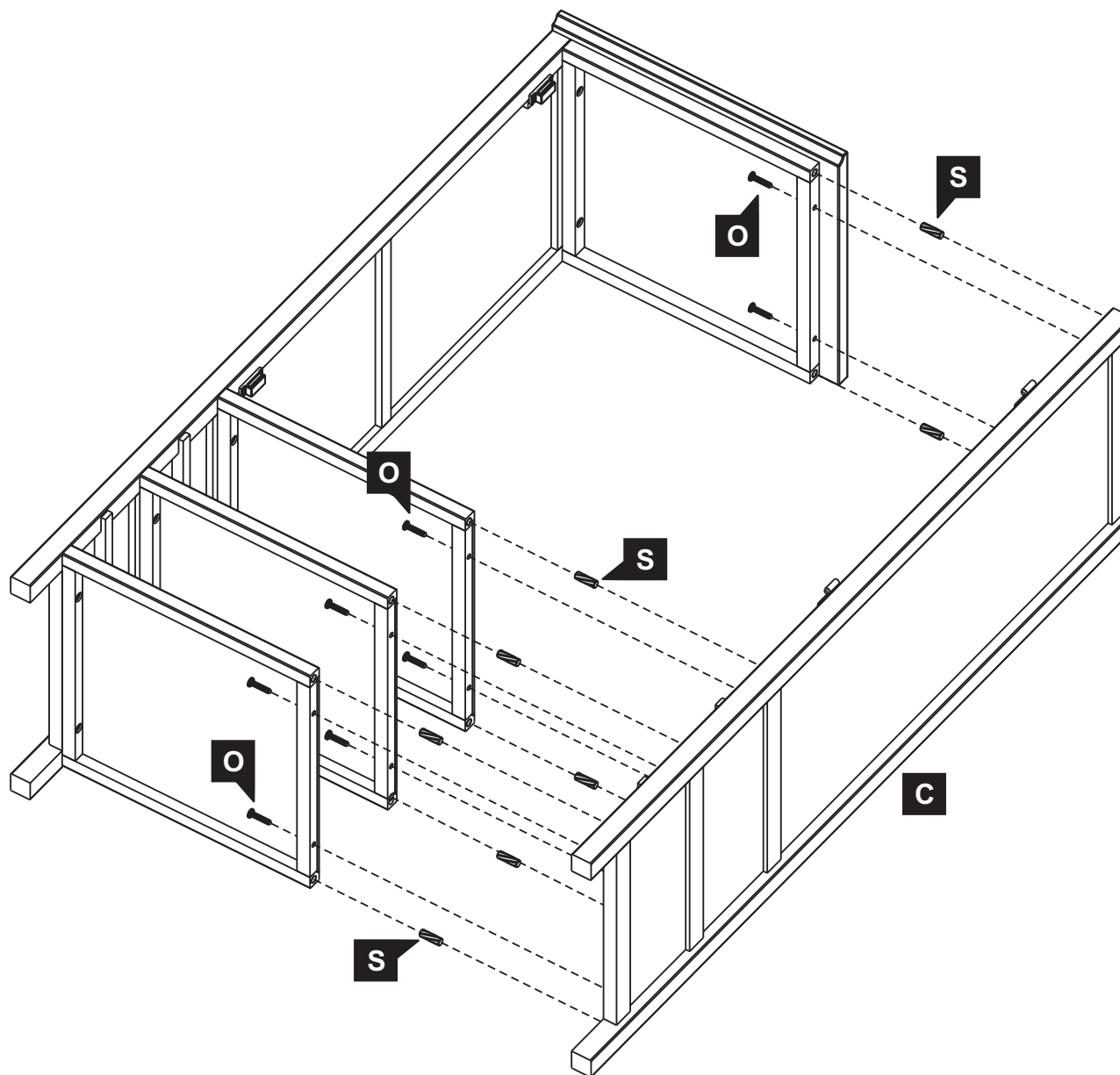

Assembly Instructions - Instructions d'assemblage - Instrucciones de ensamblaje

4

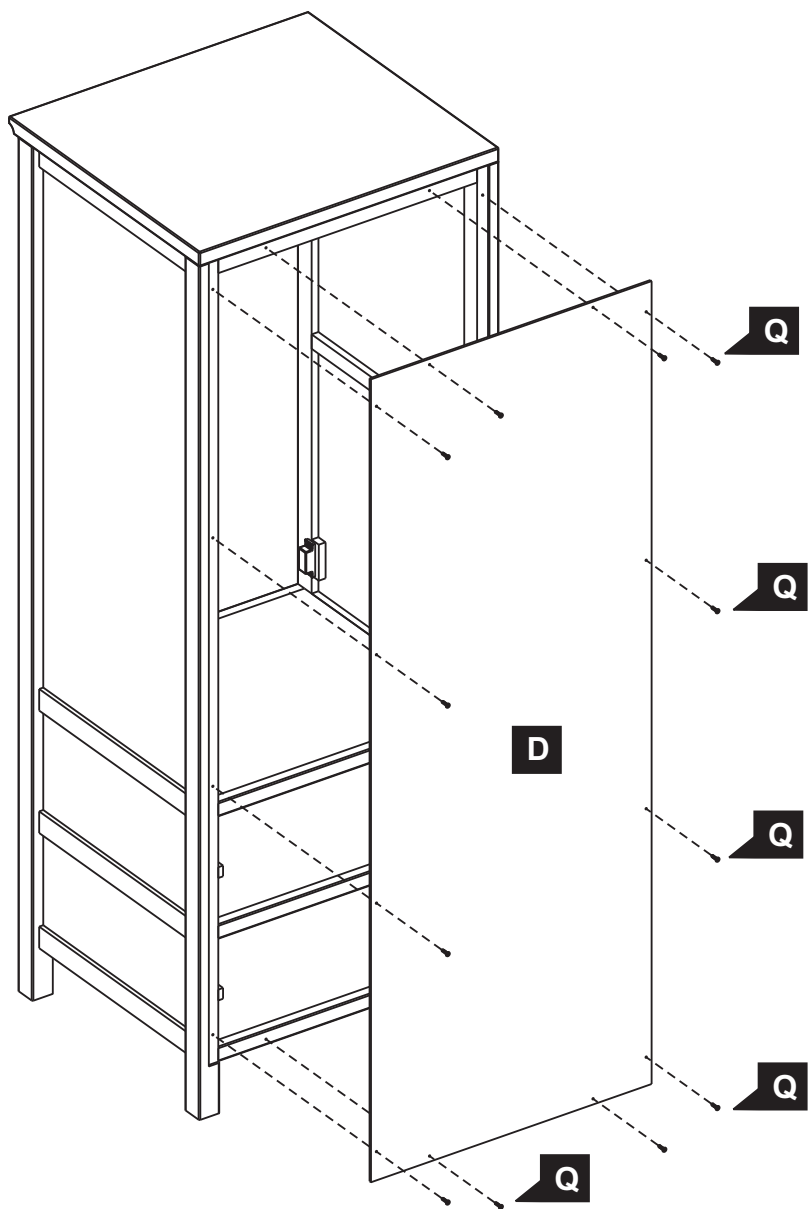

5

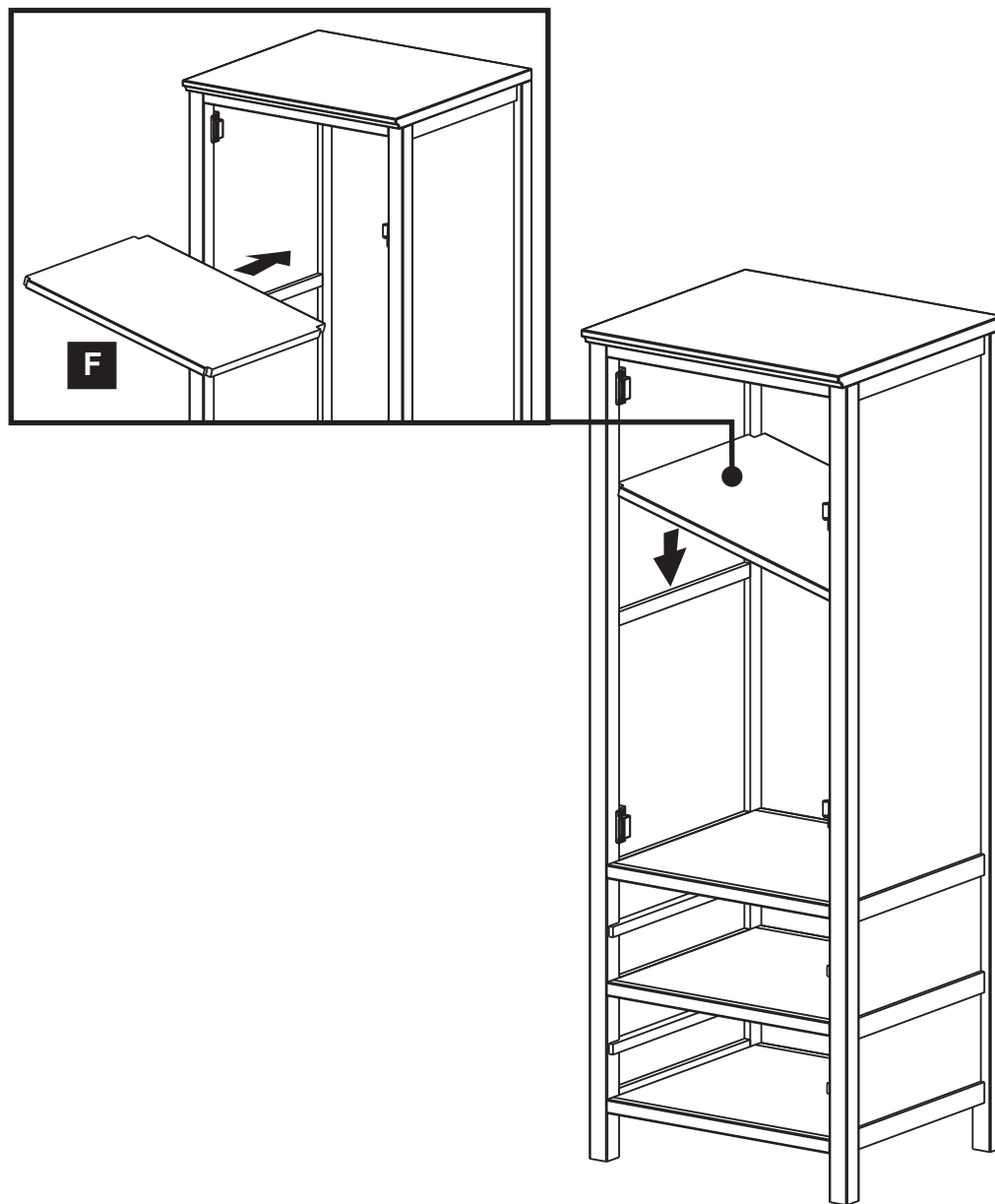

Assembly Instructions - Instructions d'assemblage - Instrucciones de ensamblaje

6 Drawer - Tiroir - Cajon
x2

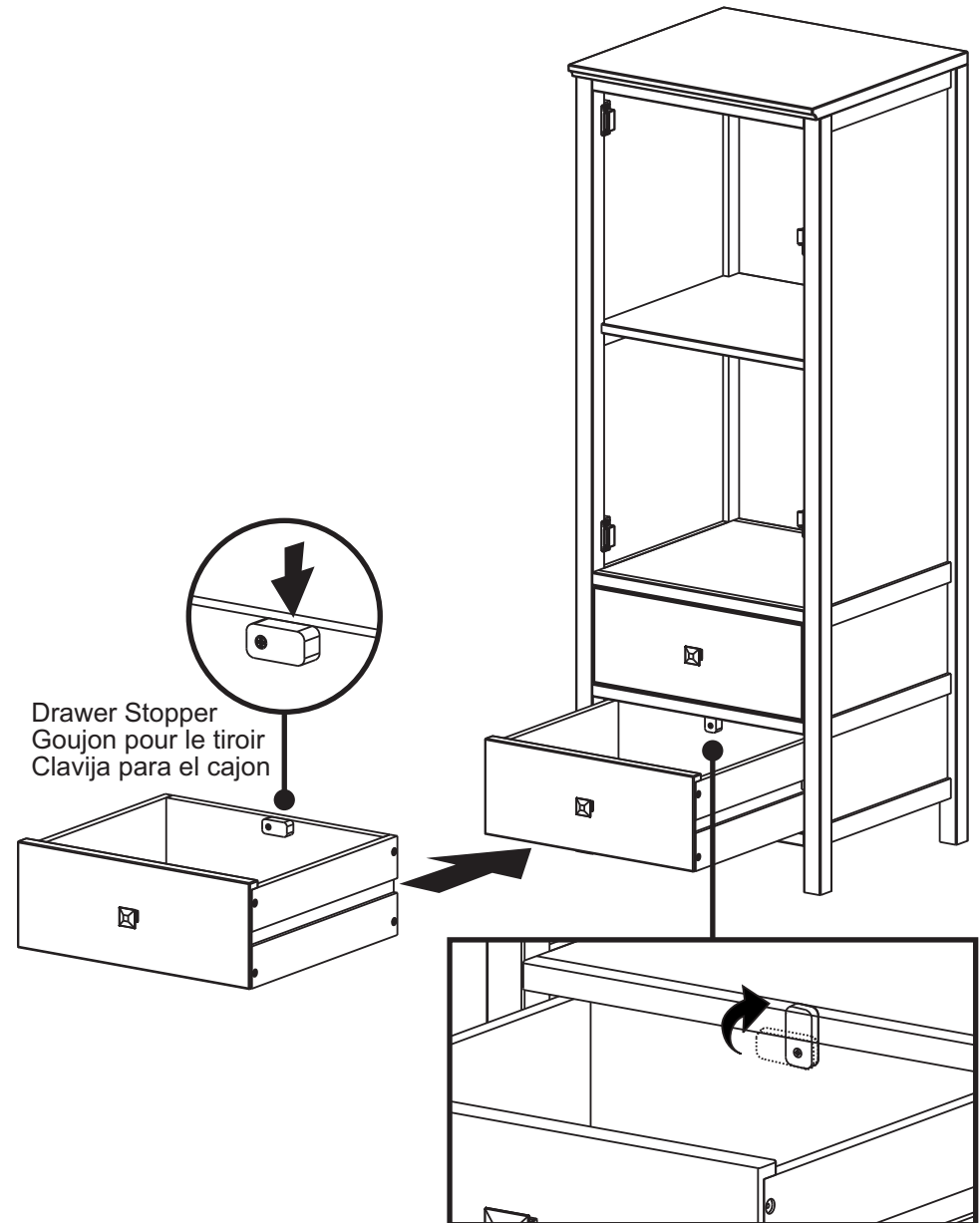
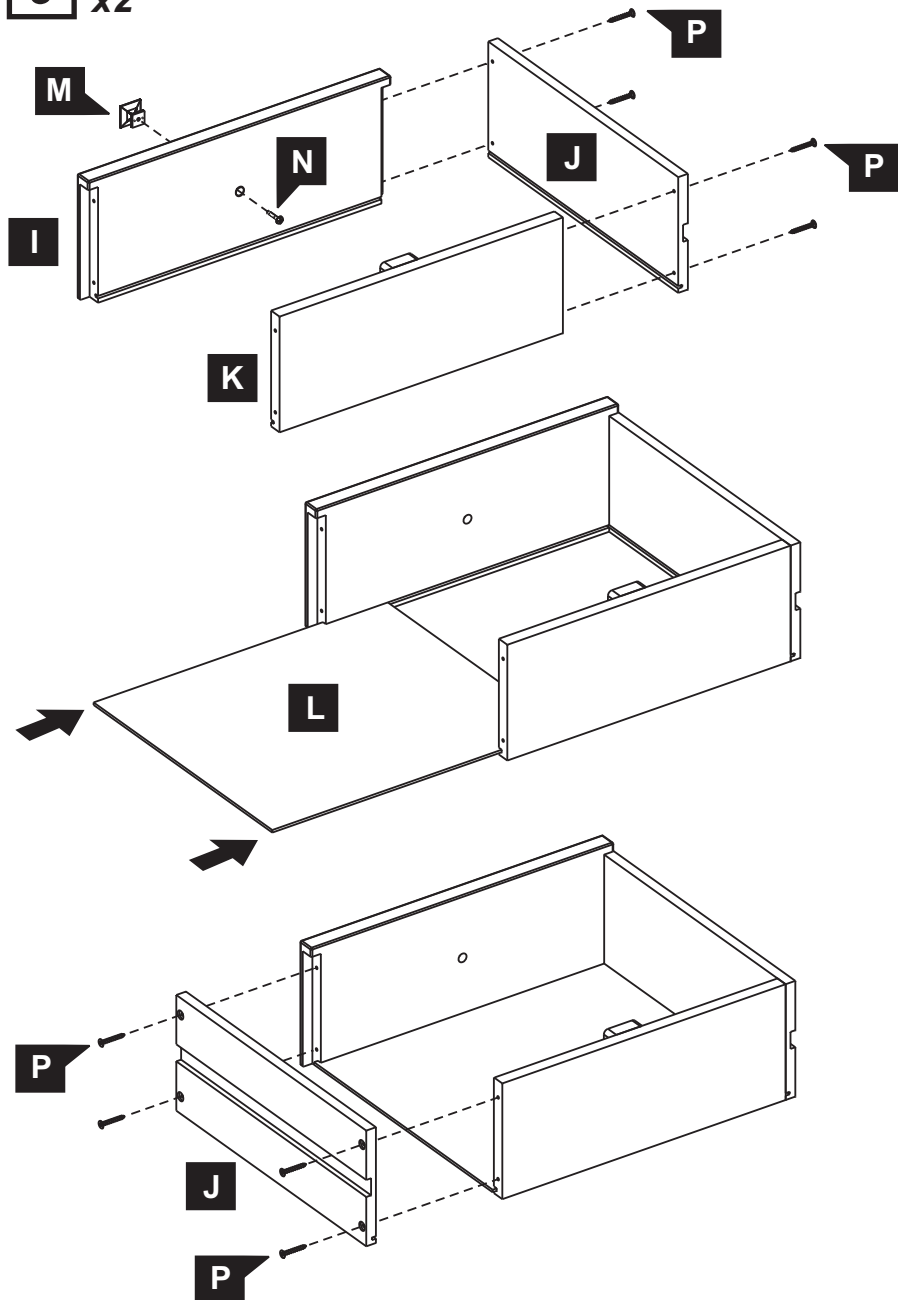

Turn Stopper UP to LOCK.
Tourner la butée vers le HAUT pour verrouiller.
Girar el pasador de madera para arriba para cerrar.

Assembly Instructions - Instructions d'assemblage - Instrucciones de ensamblaje

7

