

Attention: Do not tighten the bolts and screws before the allen bolts are in place

USER'S MANUAL

Dining Bench

20HYHTDB2401BGE

BEFORE YOU GET STARTED, A FEW POINTS



Having a friend to help makes assembly extra-easy



Mind the important safety information

PLEASE MAKE SURE ALL THE PARTS ARE INCLUDED.

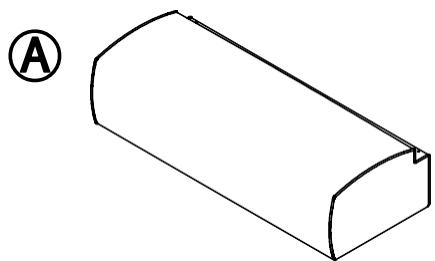

Seat frame *1

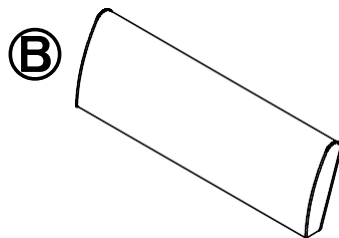

Backrest *1

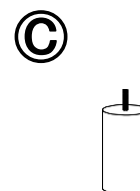

Leg *4

①



Ø 5/16 * 80mm
(5pcs)

②



Ø 5/16
(5pcs)

③



Ø 5/16
(5pcs)

④

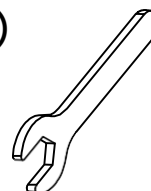

Wrench
(1pc)

Missing parts?  hyltech@outlook.com

ASSEMBLY INSTRUCTIONS - ATTENTION

STEP 1

Place all parts on a clean, scratch-free surface.

Put the Seat frame (A) upside down and unwrap the lining to take out the Legs (C)

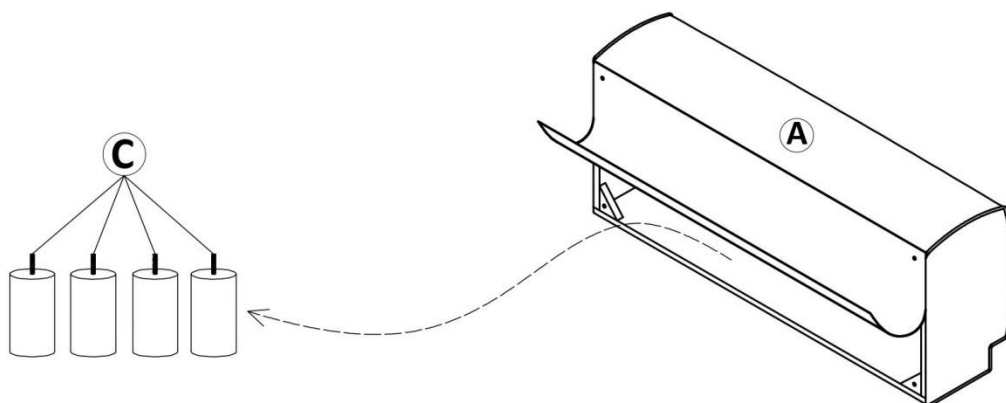

ASSEMBLY INSTRUCTIONS - ATTENTION

STEP 2

Place all parts on a clean, smooth surface.

Install the Bolts (1) to the Backrest (B) as shown below:

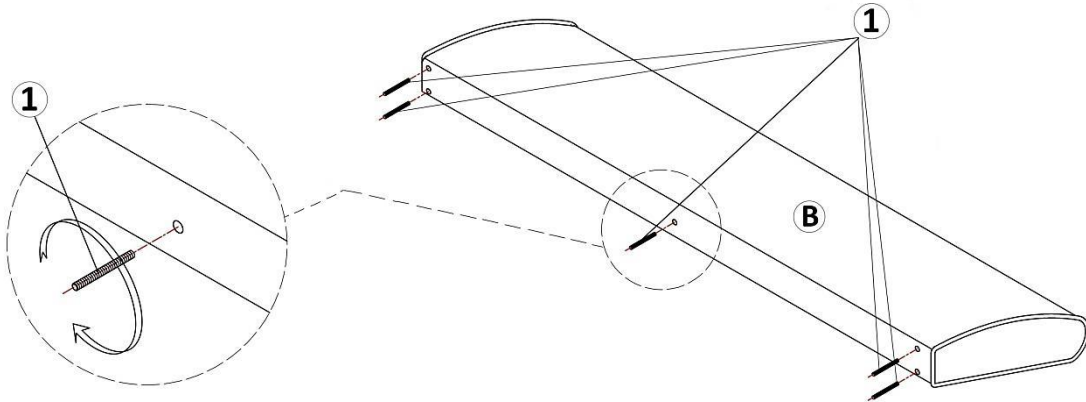

STEP 3

Install the Backrest with Bolts in step 2 to the Seat Frame (A) as shown below:

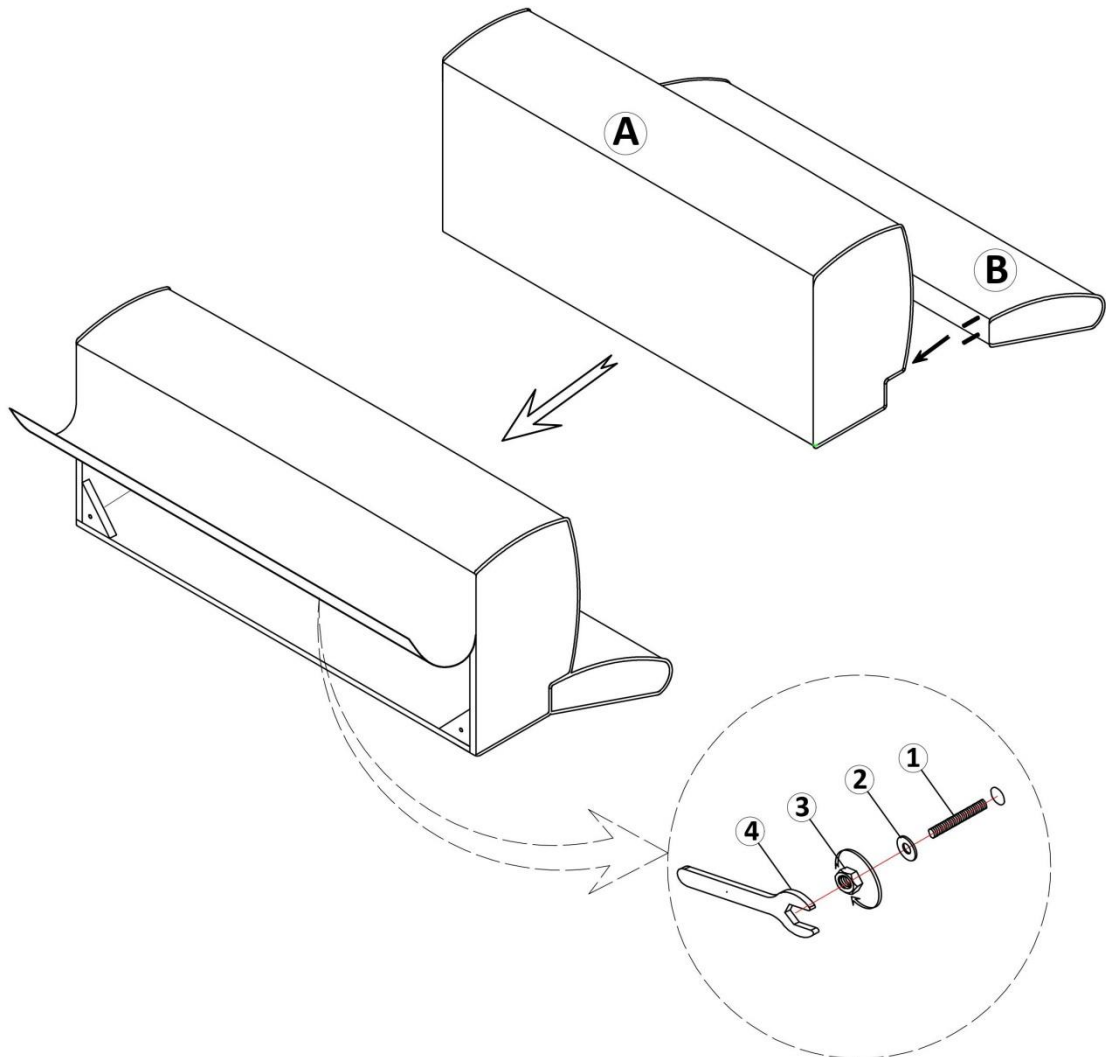

ASSEMBLY INSTRUCTIONS - ATTENTION

STEP 4

Install the Legs (C) to the bench body as shown below:

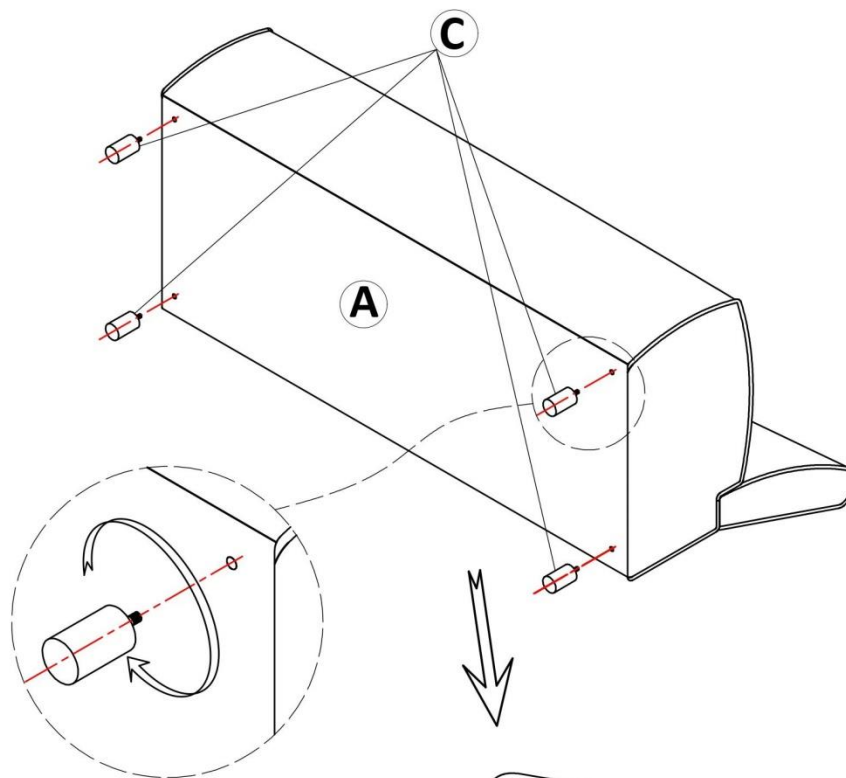

COMPLETED.

Your bench is ready to use.

This bench can only be used on a flat, leveled surface.

WARNING



Read the instructions carefully.



Please follow the assembly steps

Weight Capacity for Seating: 330LBS

To ensure proper assembly, follow all steps and use all parts, do not use power tools. Failure to follow this warning can result in serious injury to yourself or others.

Please inspect all items before assembly, if for any reason you need to return this item, please kindly return in its original packaging.

To avoid misalignments, leave the screws loose and do not tighten them until all are in their respective places.

Do not tighten all bolts and screws completely until the entire unit has been assembled and set up.

Do not over tighten or force the screws as they could break, strip, or damage the threads of the holes.

Using the wrong size of screws on a part could result in damage to the screw or the part.

Lubricate all moving parts and tighten all bolts/screws every 6 months or whenever needed.

Do not use if this product becomes damaged, and/or components are broken or missing.

SAFETY INFORMATION



Sit in the center of the chair, with your back to the backrest



Do not sit at the front edge of the chair



Do not stand on the chair



Do not use the chair with more than one person



Do not push the chair around when a person is sitting in it



Do not push down on the backrest when a person is reclined