

AFTERSALE SERVICE

Dear customer,

Thank you so much for purchasing the product from us, we really appreciate your support.

We are aimed to provide the best shopping experience to our customers. We also want to build a mutually beneficial relationship with our customers, and step further to make our brand both reliable, responsible and recommendable.

We hope that our products could meet your needs and expectations, please consider us again if you need more products for your home and kitchen.

The package would be out of our control during shipping, please contact us through your purchasing channel directly if there is anything wrong with the box or contents. We are always here offering you our service.

We will reply your messages within 24 hours, please kindly wait for the response from our team.

Your comfort and contentment are of utmost importance.

Best Regards,
Customer Care Specialist

ASSEMBLY INSTRUCTIONS

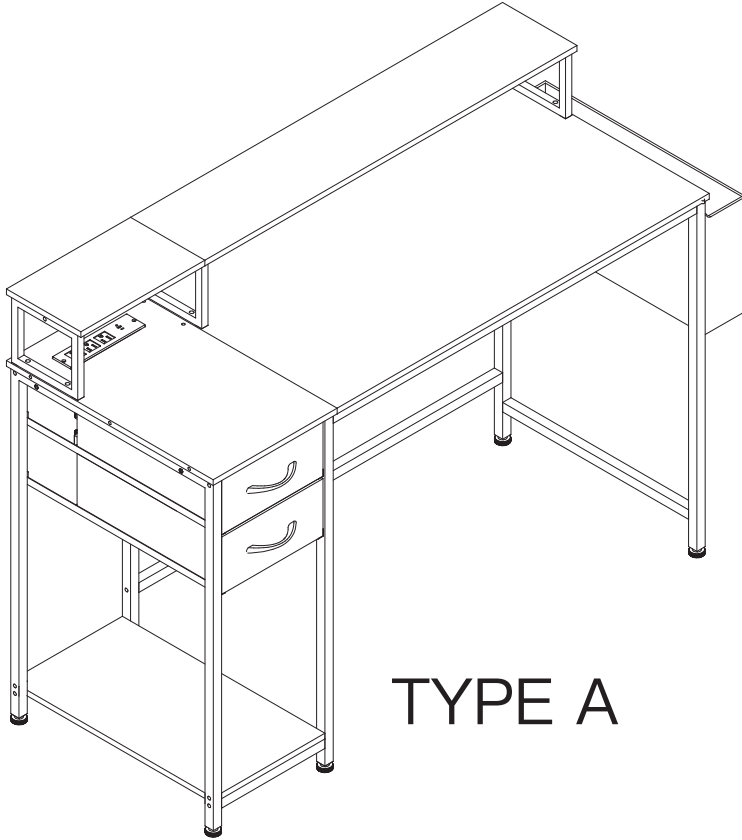

TYPE A

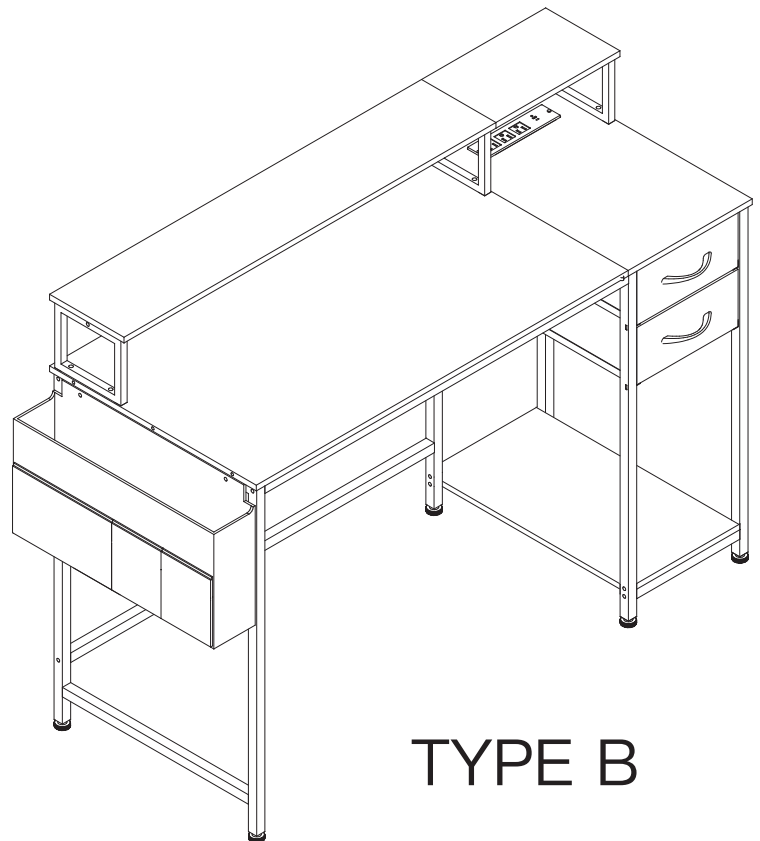

TYPE B

Please check all parts and accessories according to the parts list before assembling, make sure all contents are sufficient and in good condition. If there is any parts missing or defective, please contact us with purchase platform message immediately to get replacement parts.

PARTS:

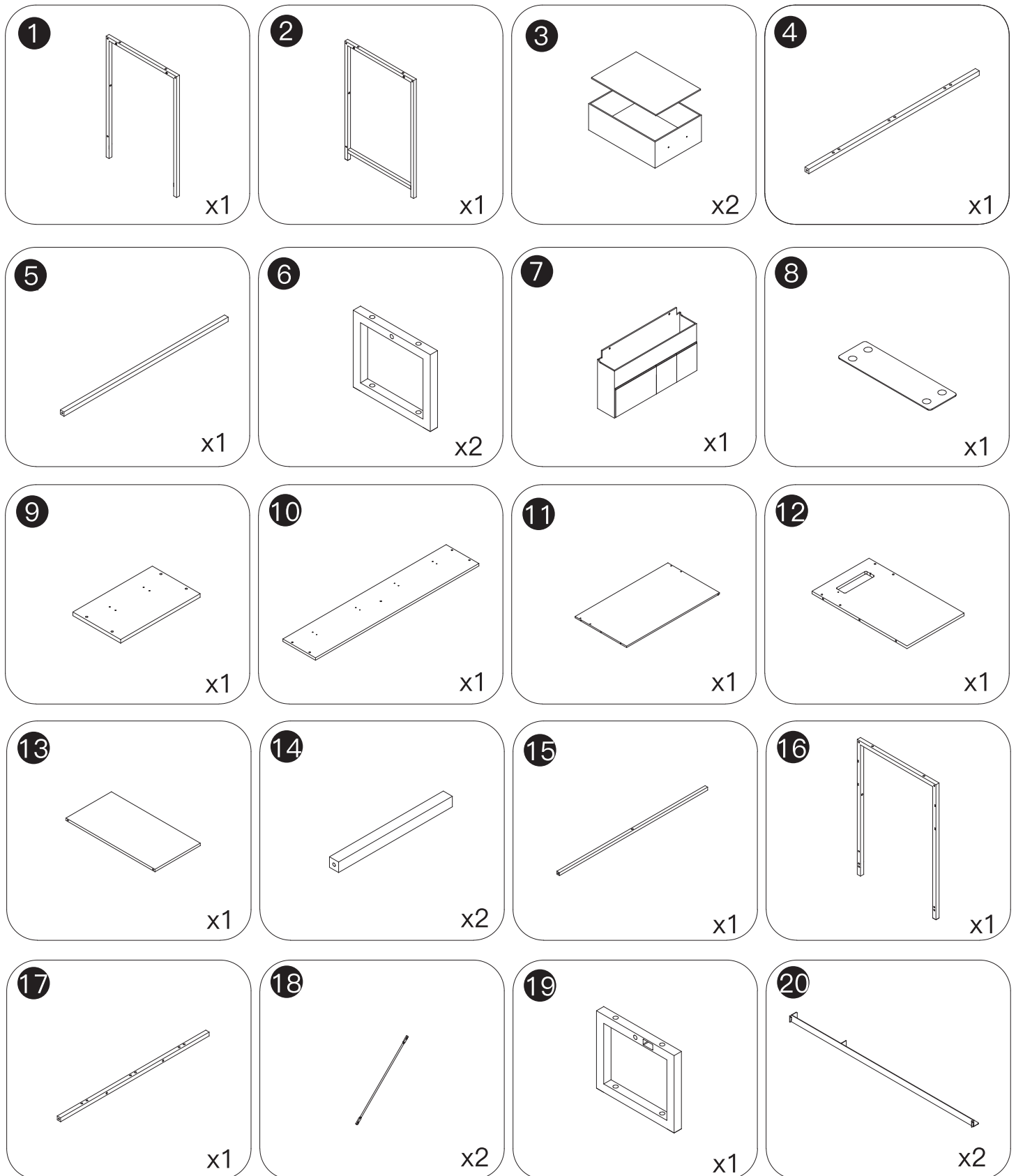



⚠ CAUTION:

- READ THE INSTRUCTION MANUAL BEFORE ASSEMBLING
- READ THE INSTRUCTION MANUAL BEFORE ASSEMBLING
- IDENTIFY, SORT AND COUNT ALL THE PARTS WITH TAGS
- ASSEMBLE IN AN AREA WITH PLENTY OF SPACE
- READ EACH STEP BEFORE BEGINNING CONSTRUCTION
- ASSEMBLE ACCORDING TO THE ILLUSTRATION IN CORRECT STEPS
- NEVER FORCE THE SCREWS OF FITTINGS
- KEEP THIS MANUAL FOR FUTURE REFERENCE
- TIGHTEN ALL THE SCREWS EVERY 6 MONTHS
- SHIFT OR DRAG THE DESK AFTER ASSEMBLY CAREFULLY
- POWER TOOLS SHOULD NOT BE USED TO ASSEMBLE THIS DESK

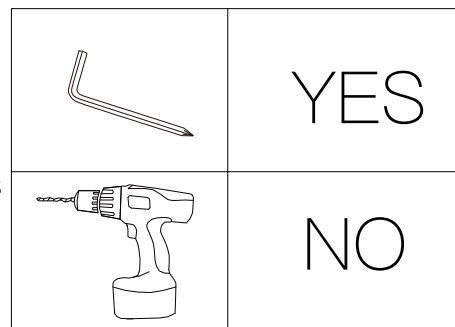

TYPE-A INSTALLATION

EXPLODED DRAWING:

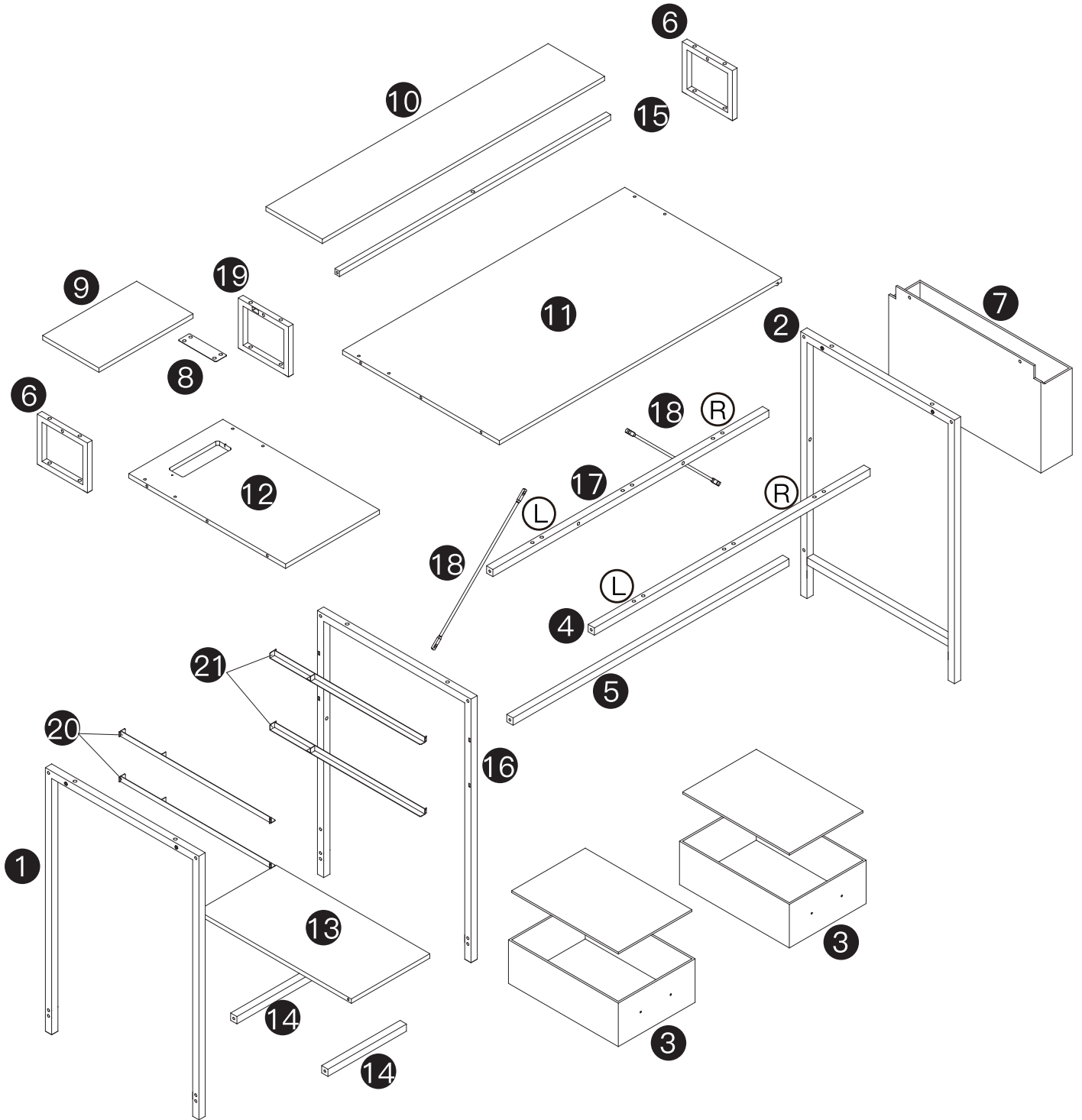

STEP 1

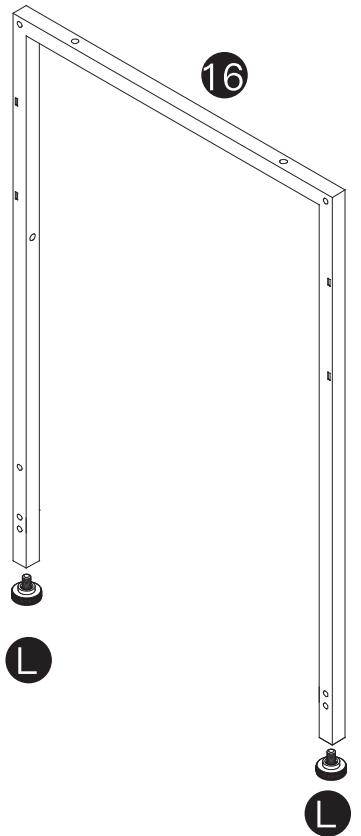
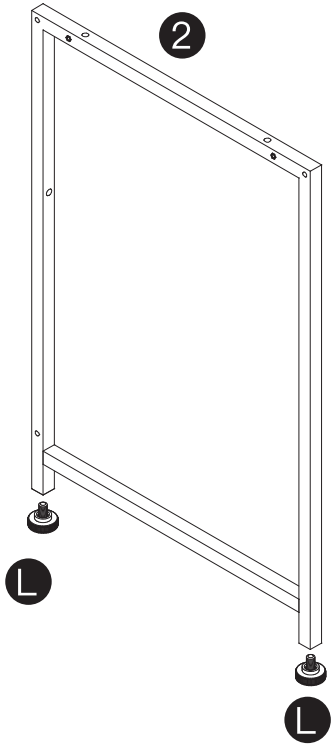
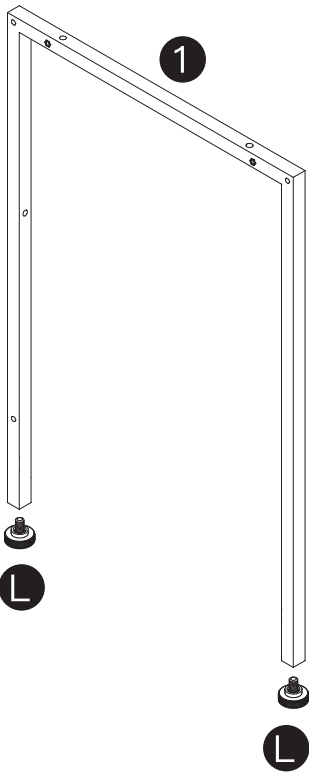
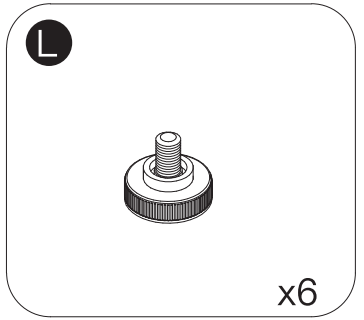
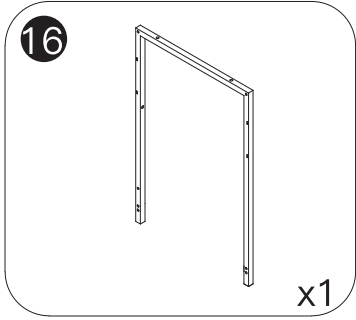
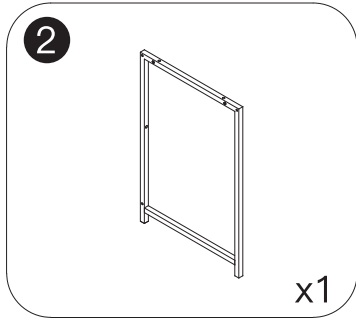
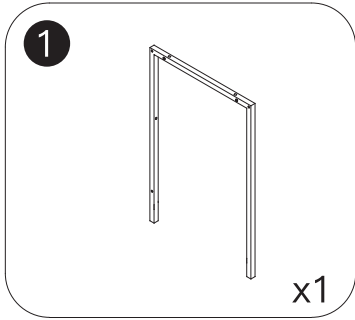

STEP 2

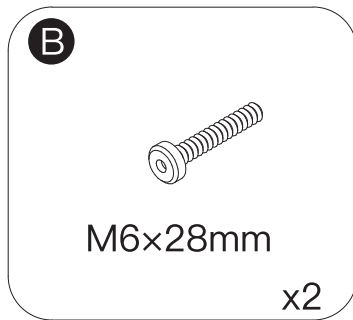
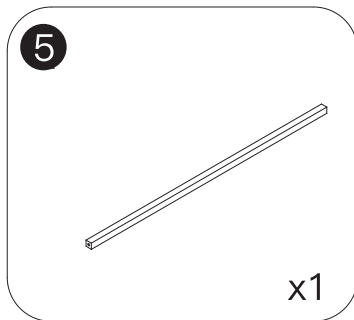

NOTICE:

Please ensure that the hole of part 2 & 16 is facing upwards.

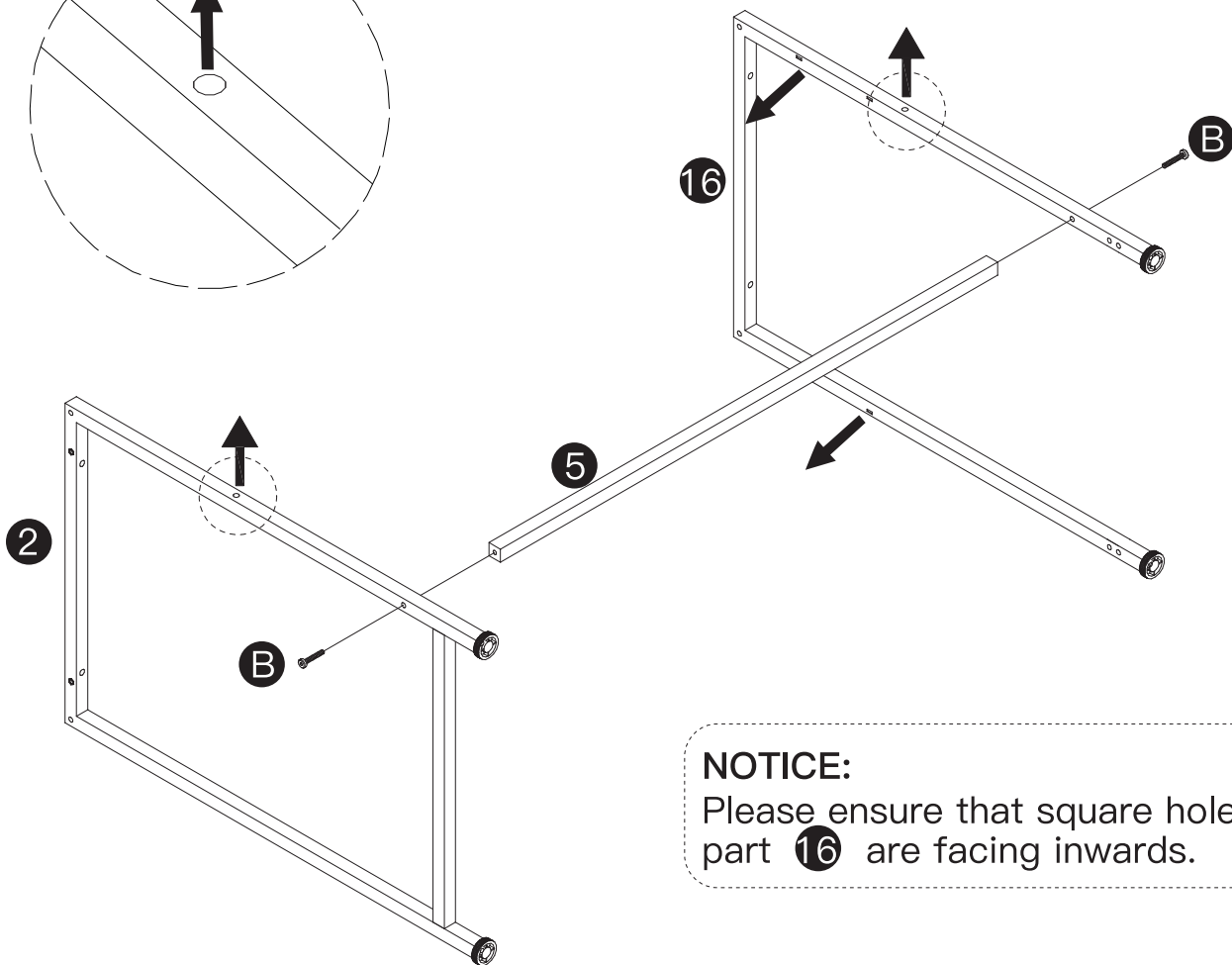
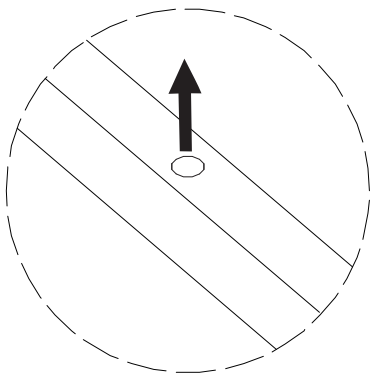

NOTICE:

Please ensure that square holes of part 16 are facing inwards.

STEP 3

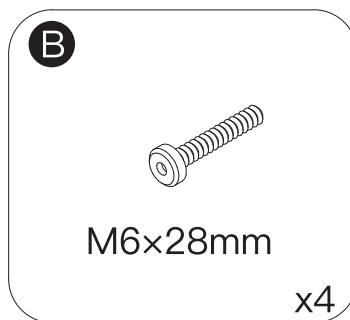
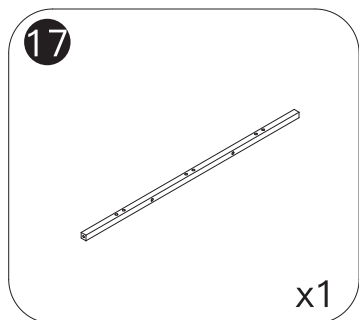
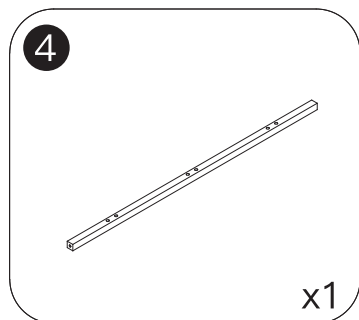

NOTICE:

(1) Please distinguish (L) and (R) on part 4 and 17 by the distance between the middle hole and the edge before installation.

(2) Please ensure that the side with 2 holes of part 17 is facing upwards.

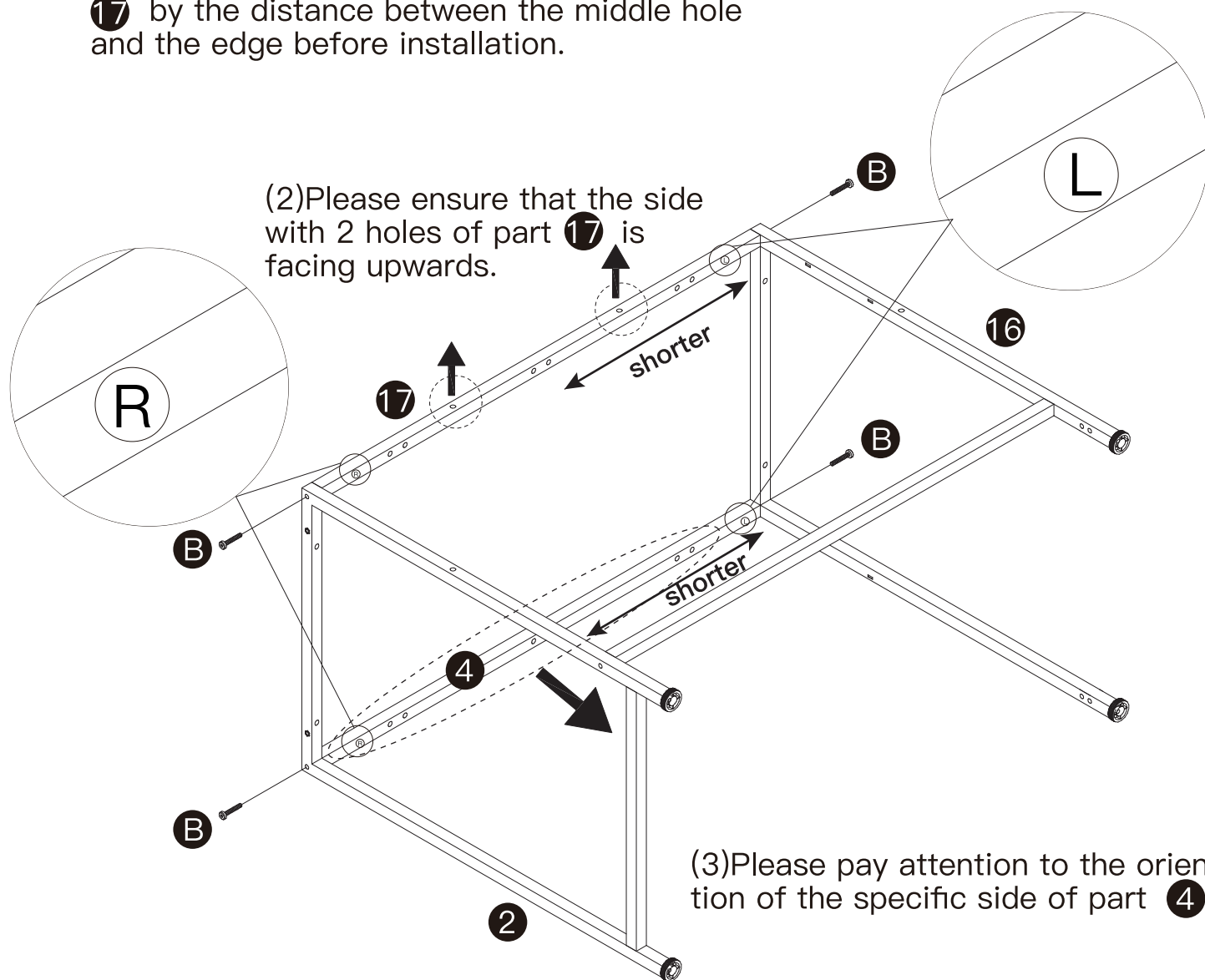

(3) Please pay attention to the orientation of the specific side of part 4.

STEP 4

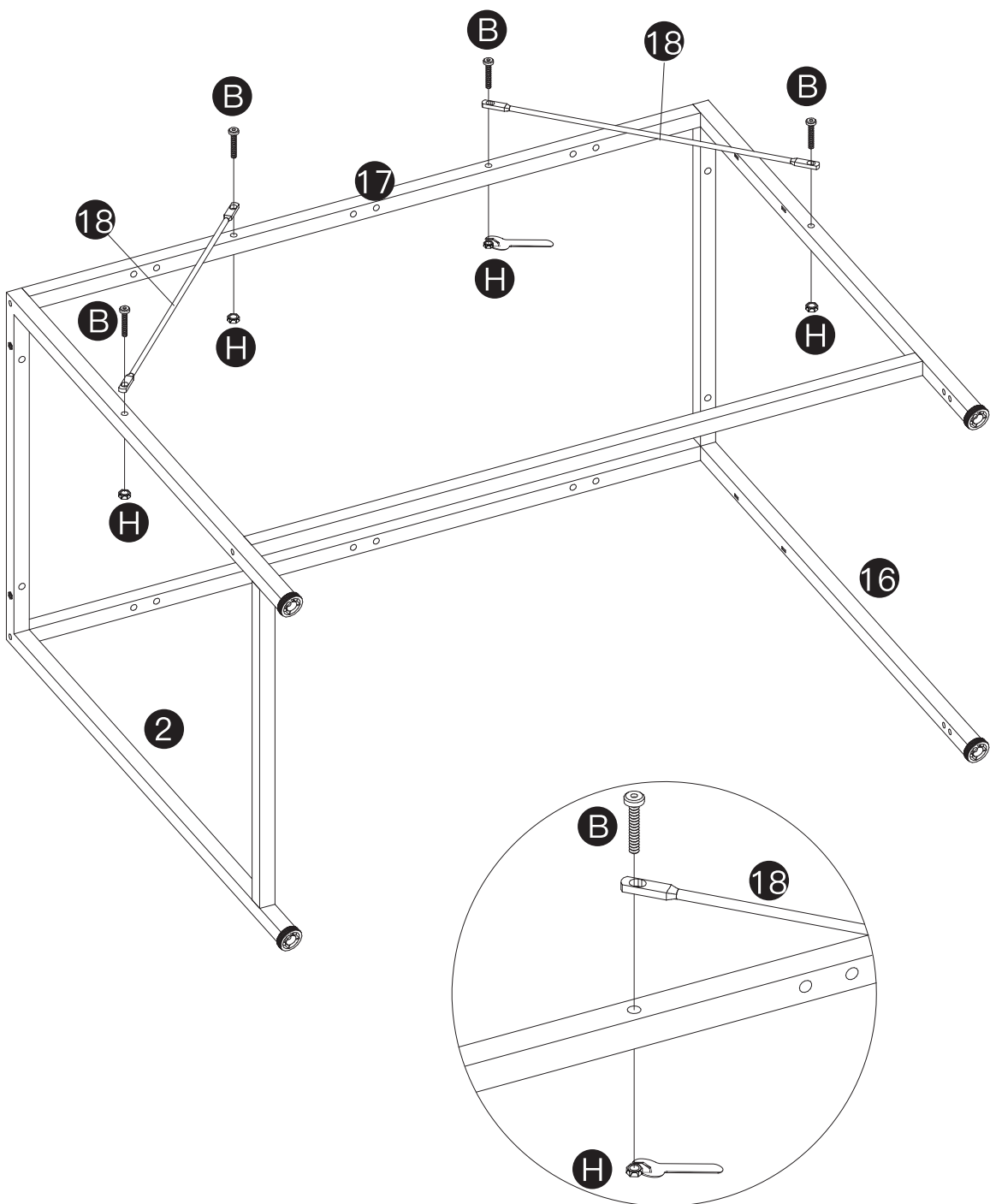
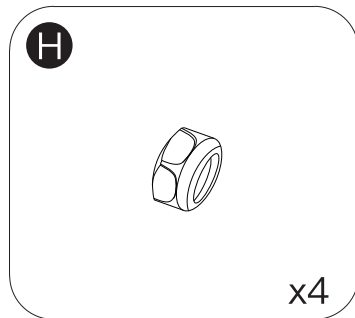
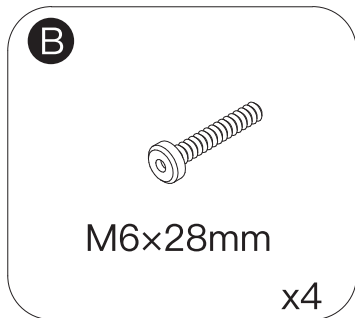
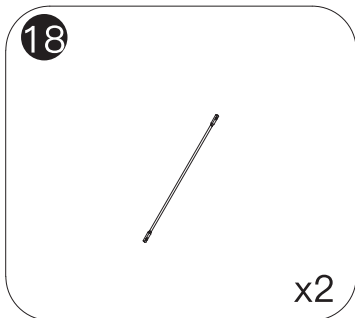

STEP 5

14

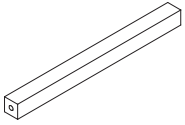

x2

B

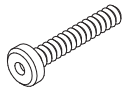

M6x28mm

x2

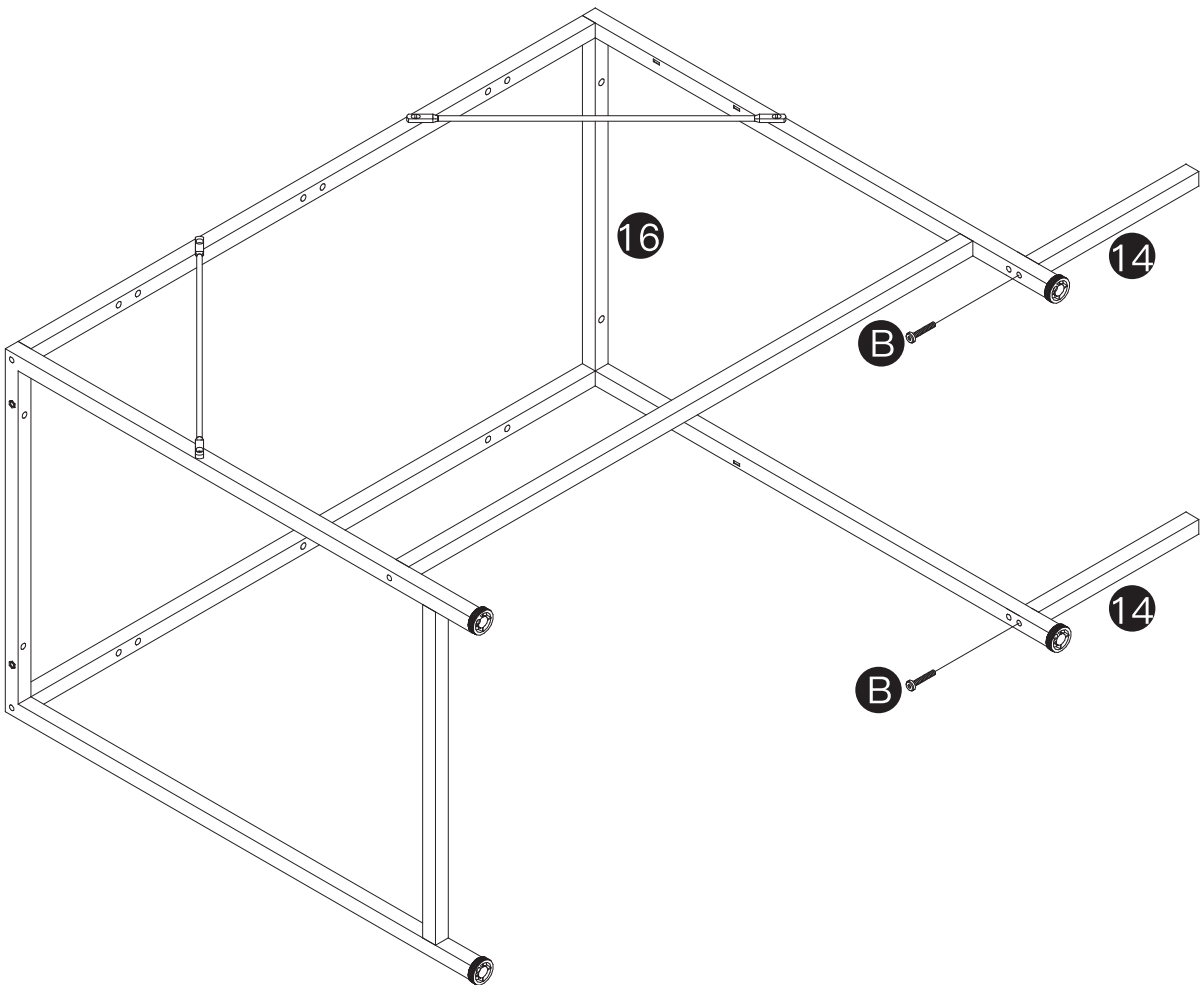

STEP 6

13

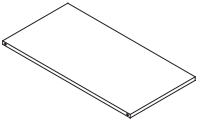

x1

D

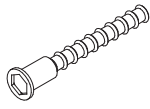

M5x48mm

x2

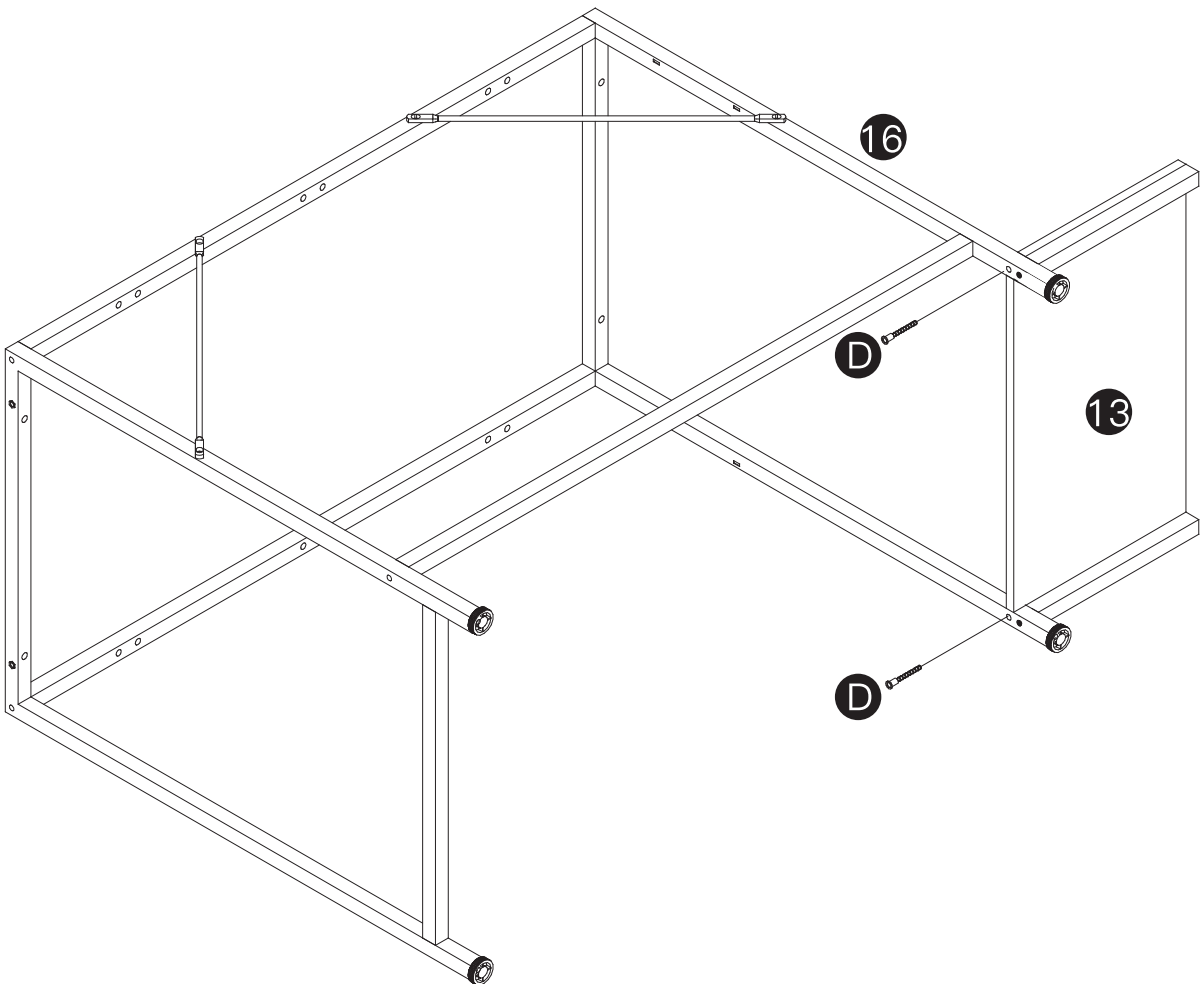

STEP 7

B

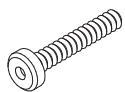

M6x28mm

x2

D

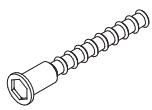

M5x48mm

x2

NOTICE:

Please ensure that square holes of part **1** are facing inwards.

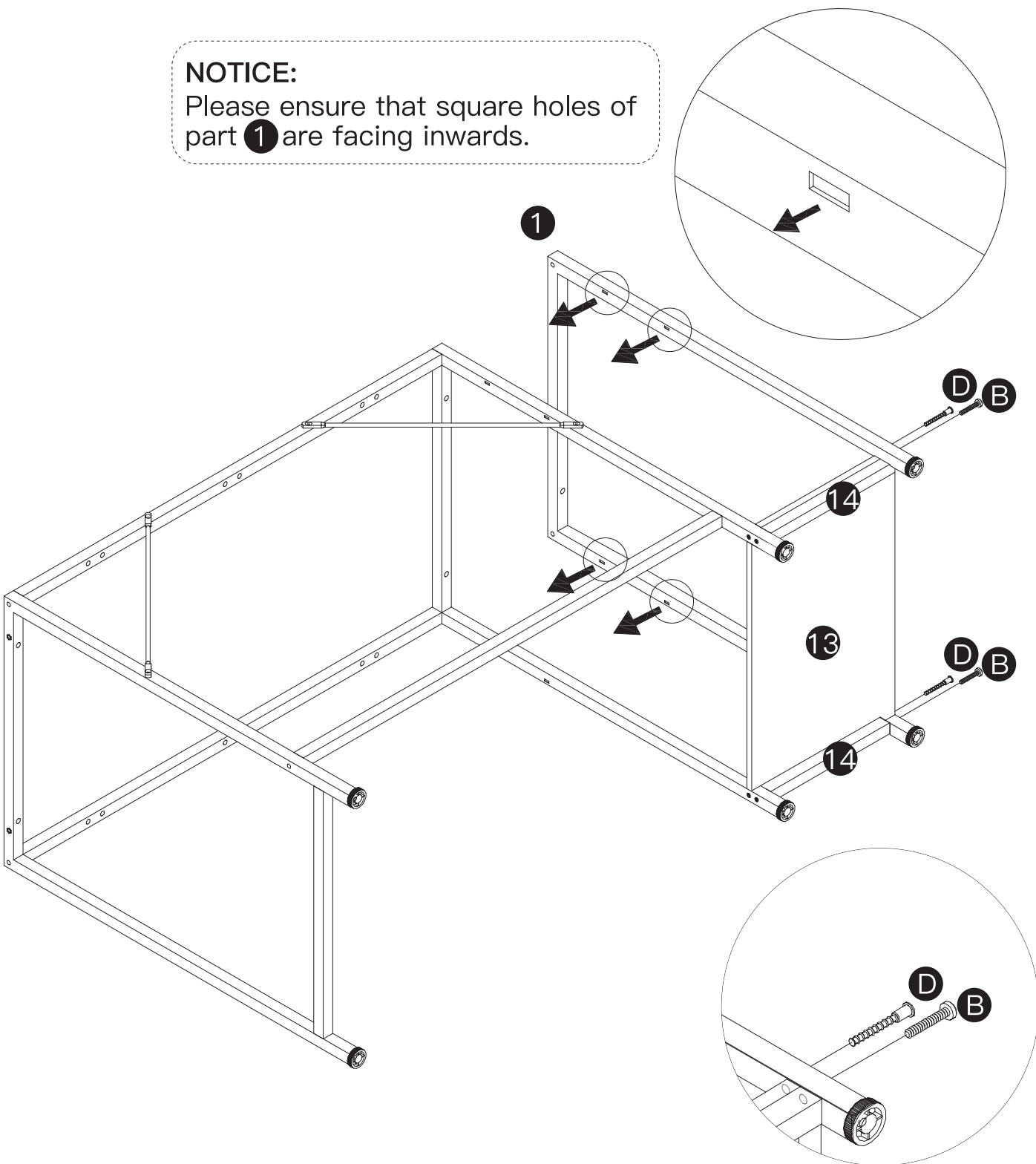

STEP 8

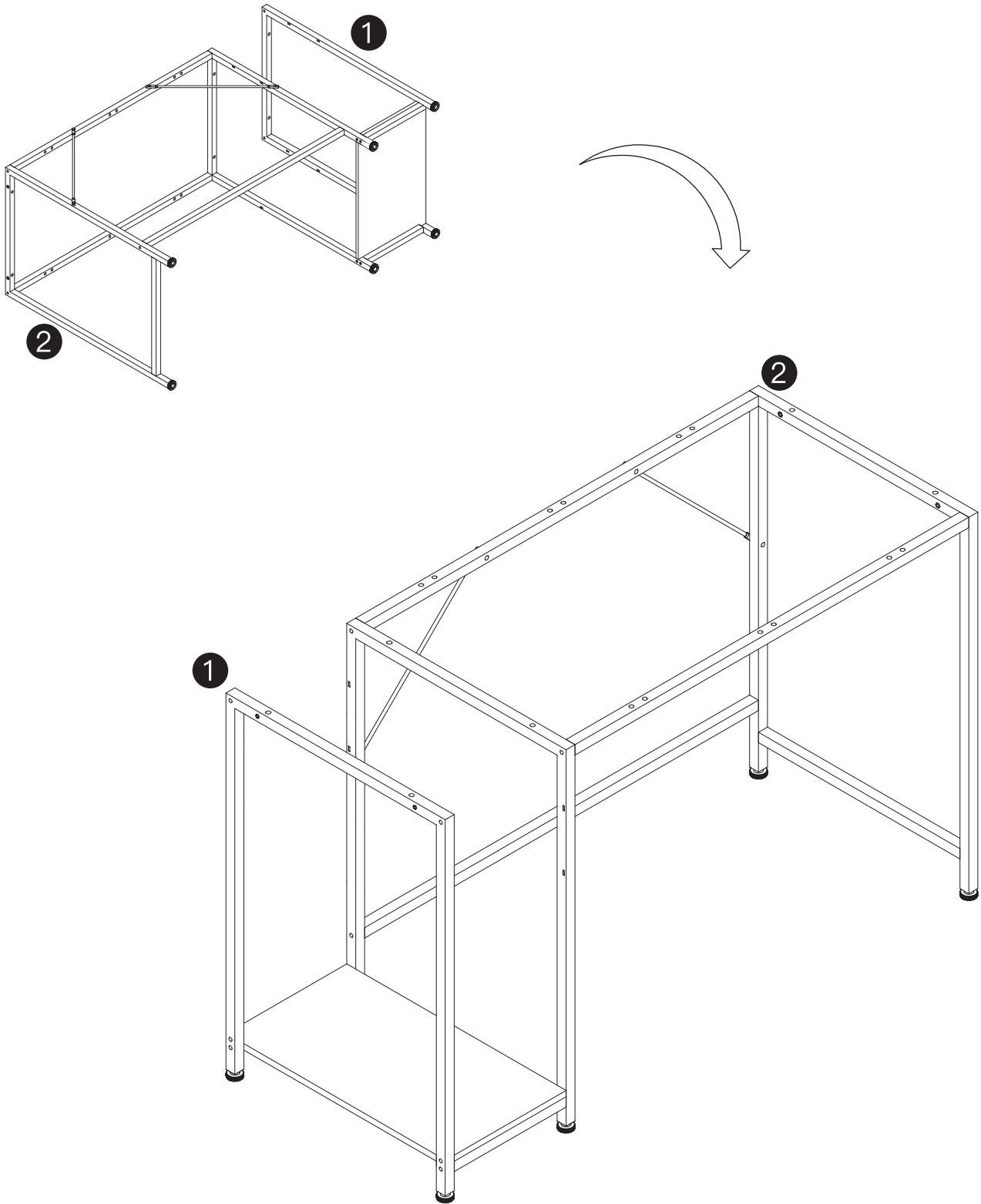

STEP 9

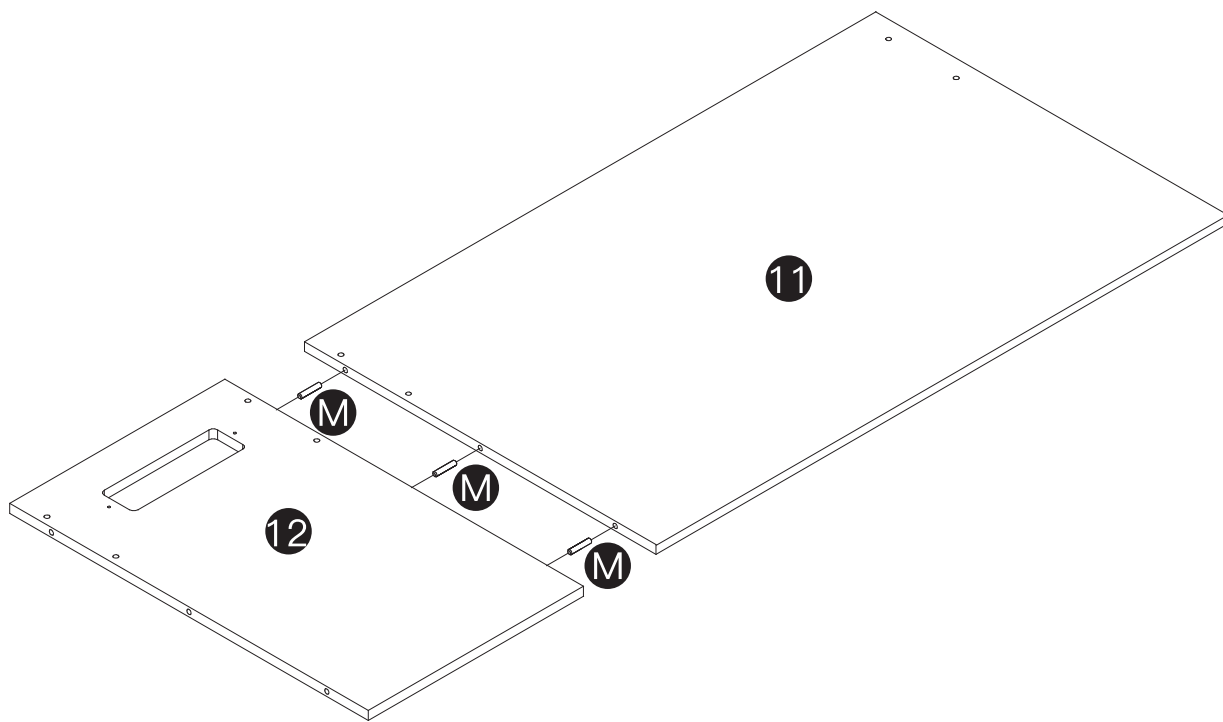
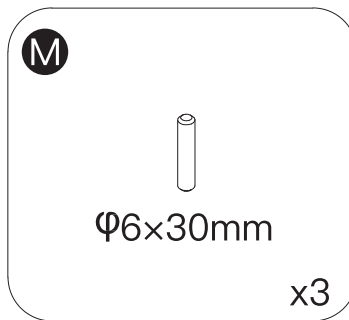
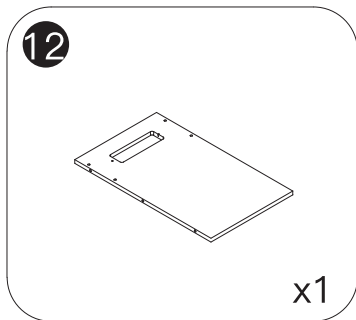
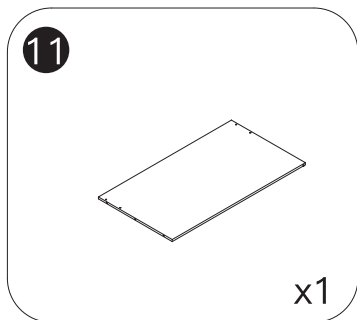

STEP 10

B

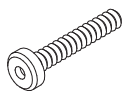

M6x28mm

x12

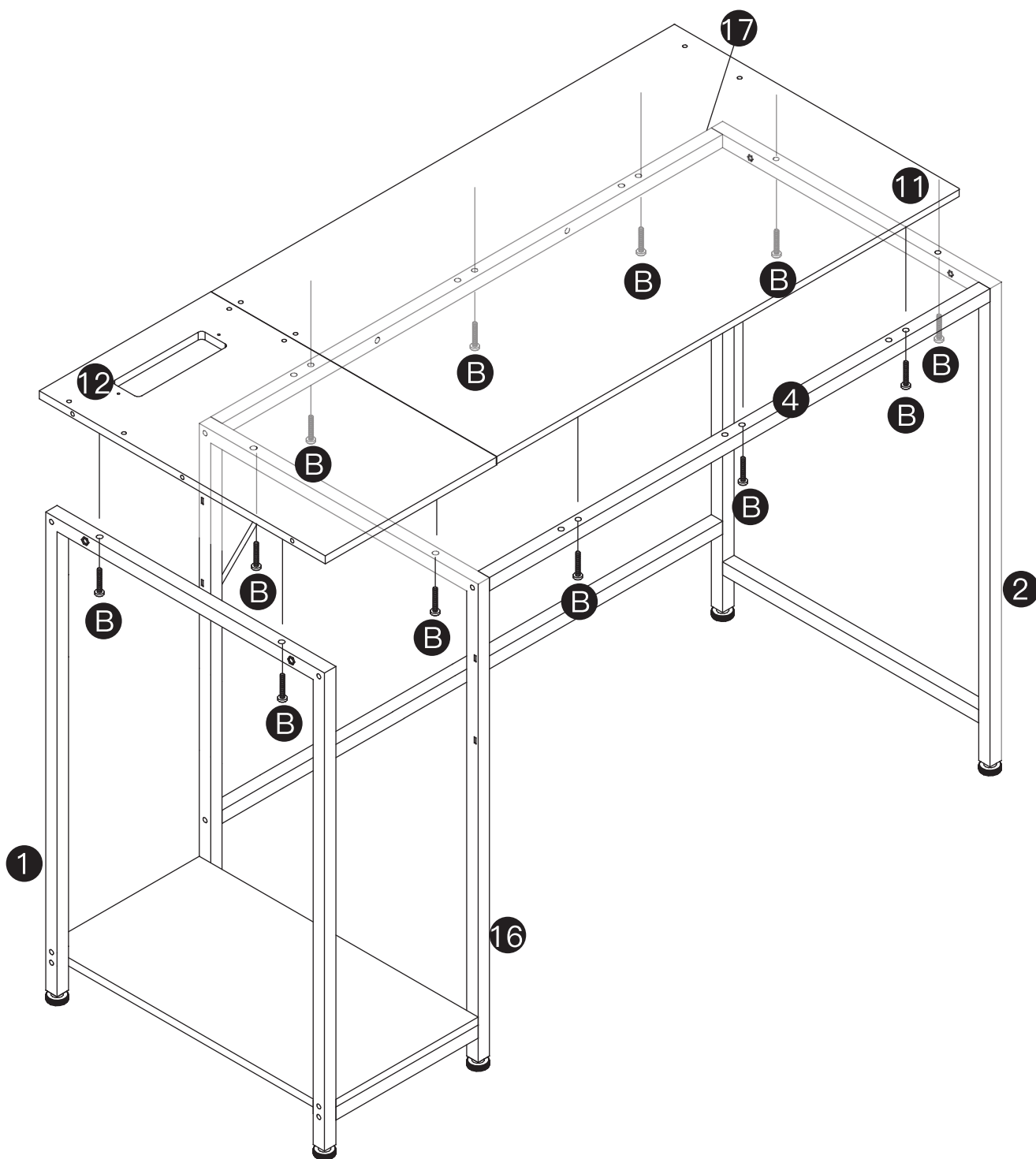

STEP 11

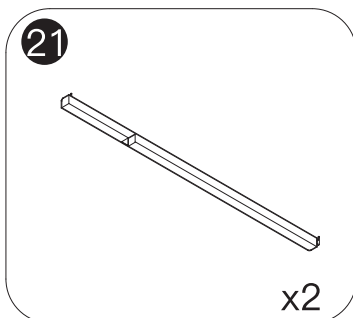
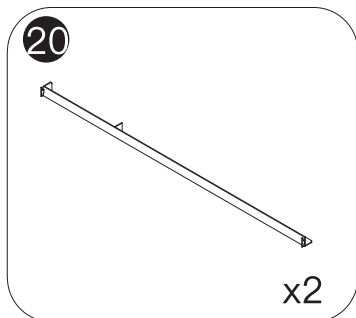

There's a corresponding L and R mark on each part located in a specified spot designed to distinguish them from each other easily.

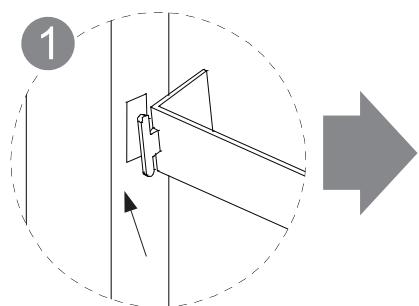
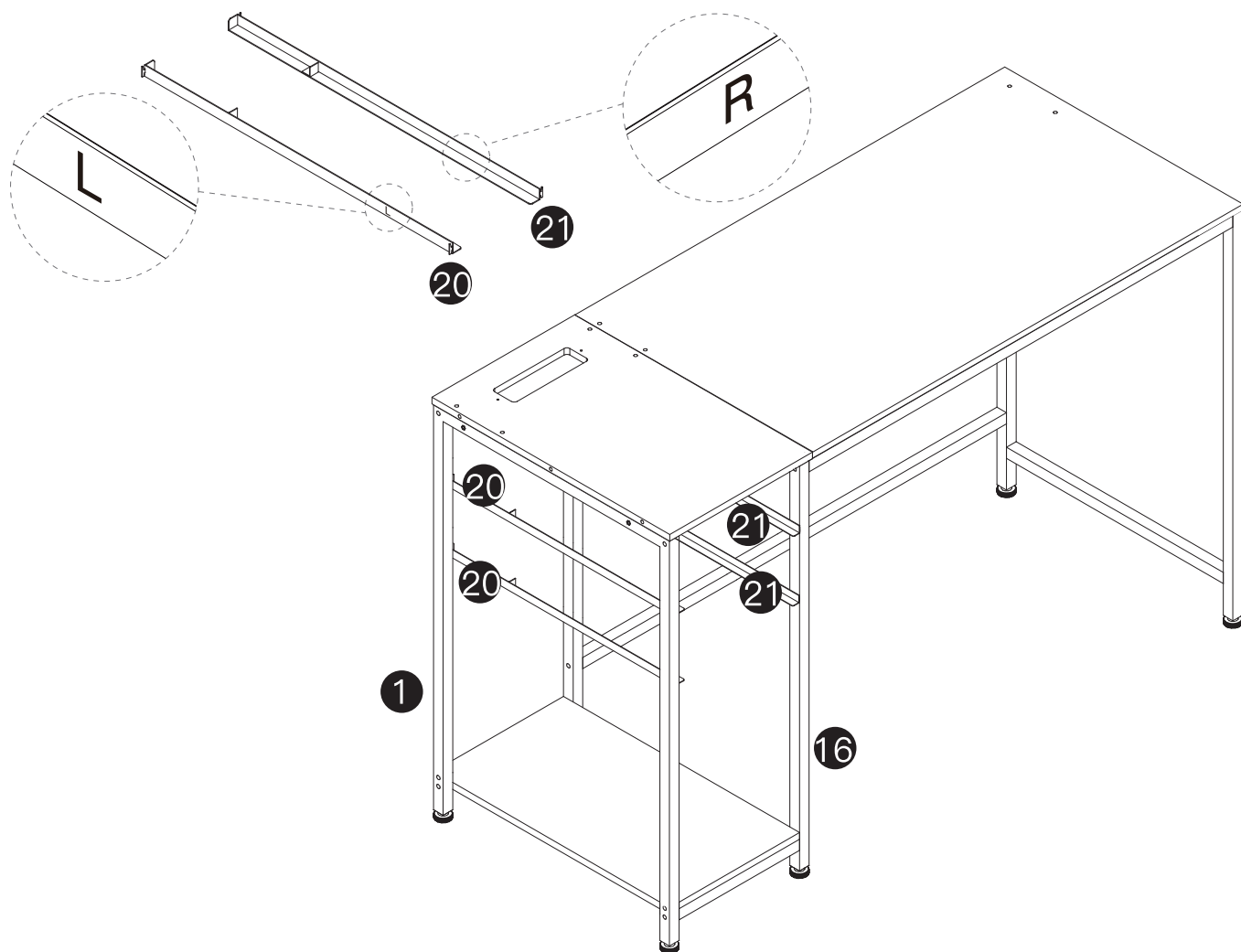

1
Insert the upper part into the square hole.

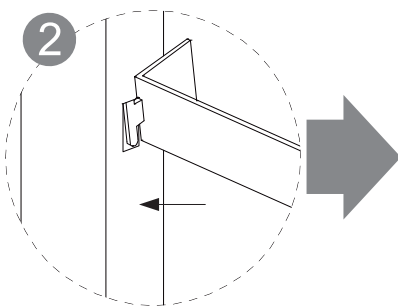

2
Then insert the rest part horizontally.

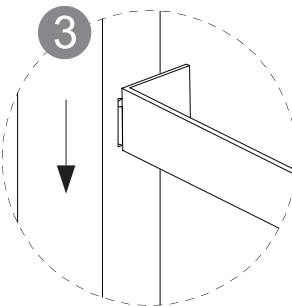

3
Press down the rail to ensure proper installation.

STEP 12

7

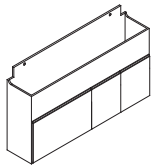

x1

T

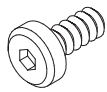

M6x15mm

x2

NOTICE:

Part 7 can be installed on either part 1 or part 2.

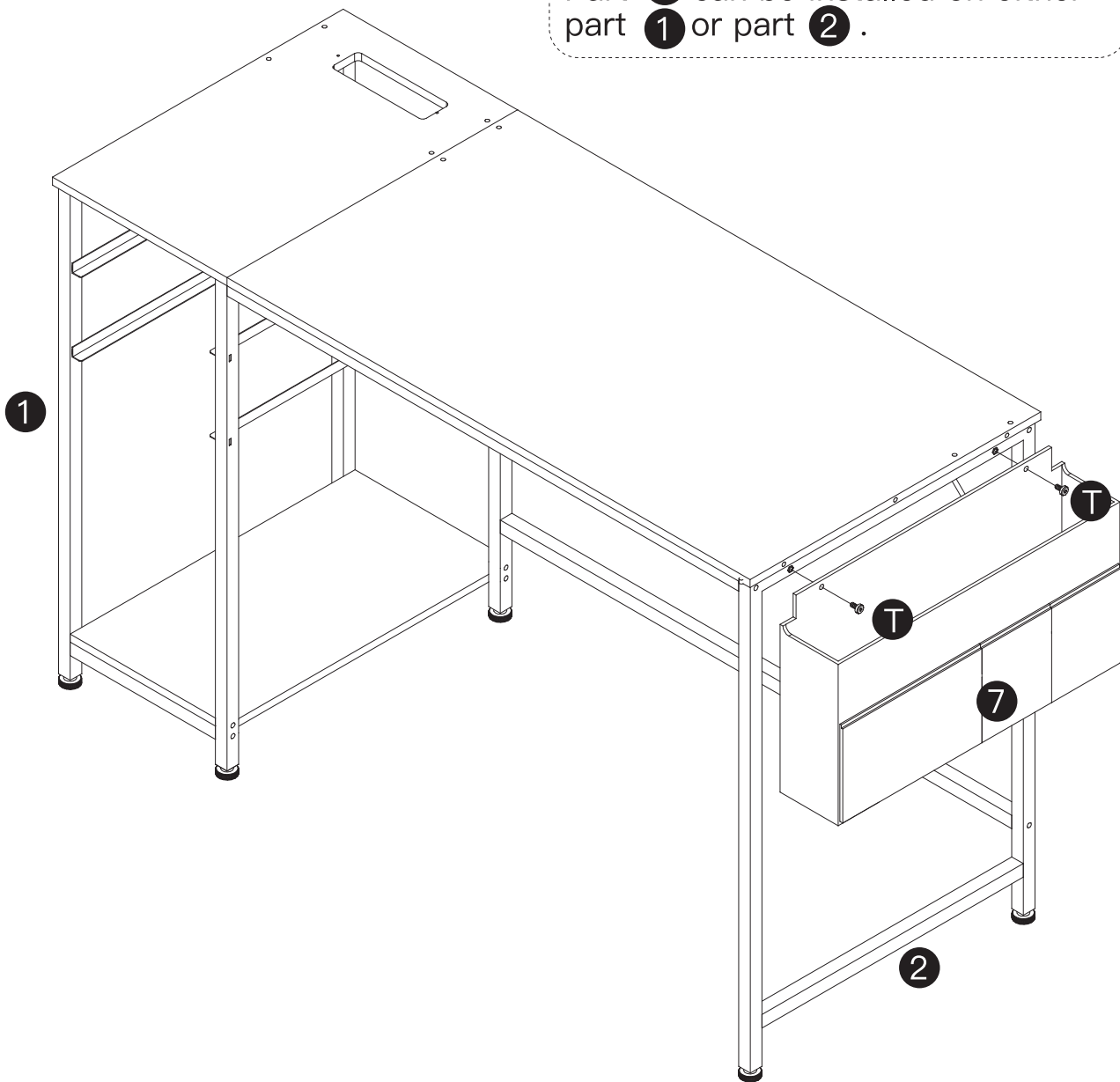

STEP 13

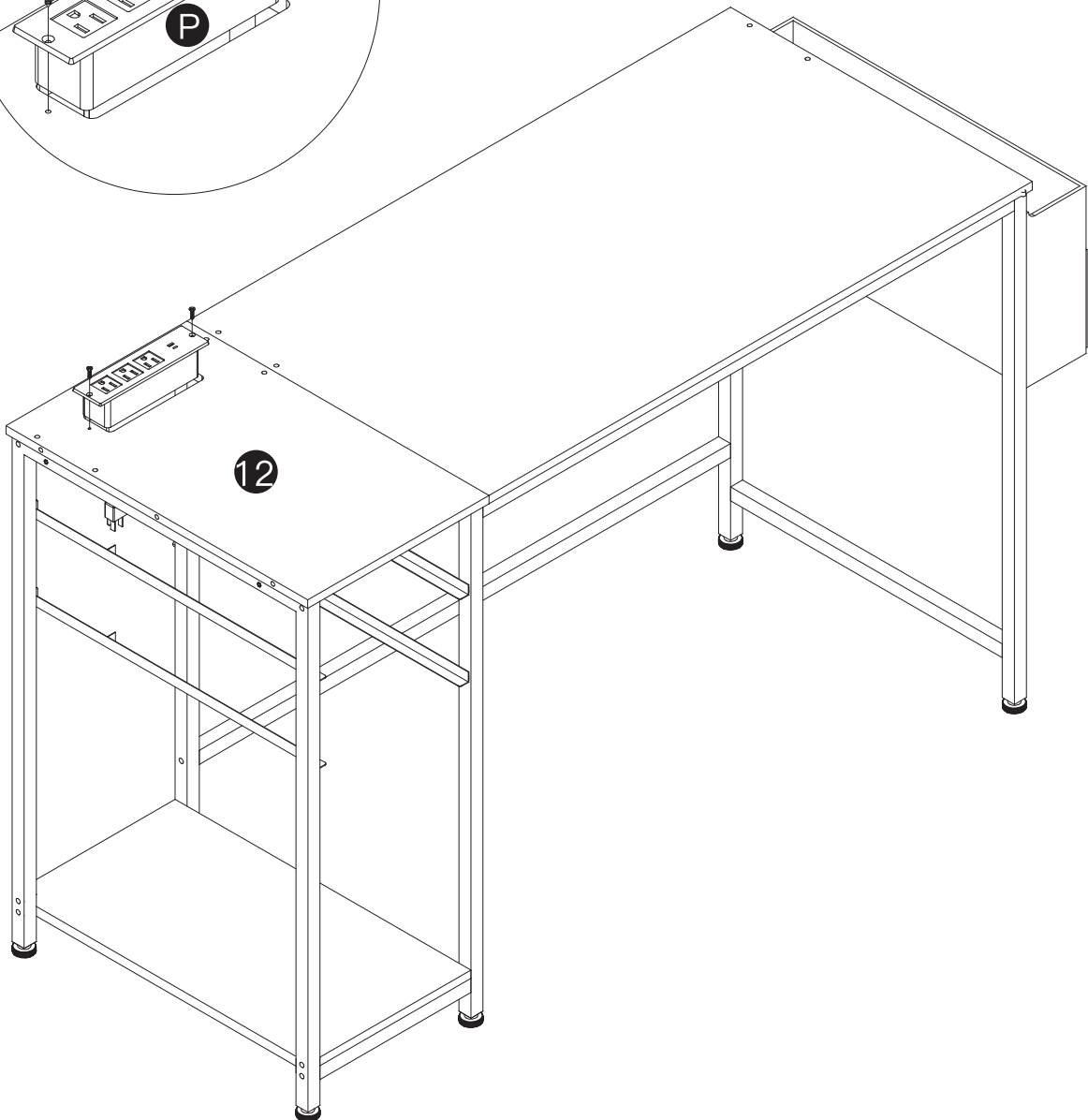
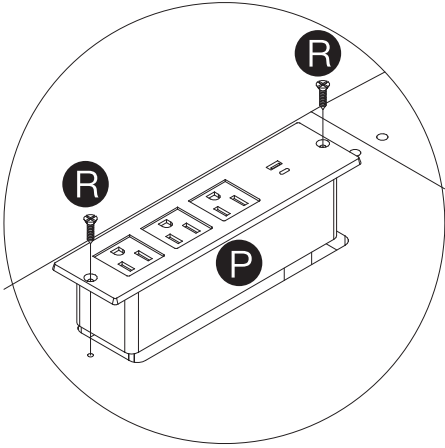
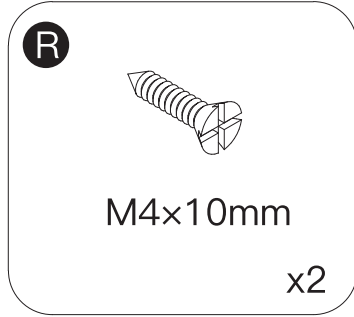
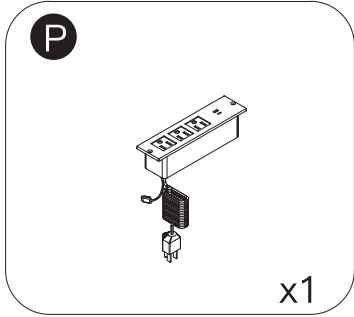

STEP 14

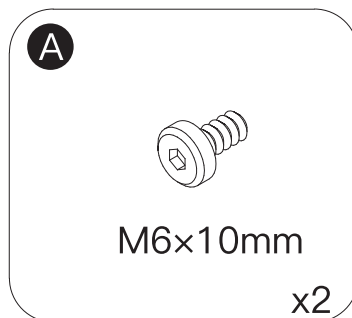
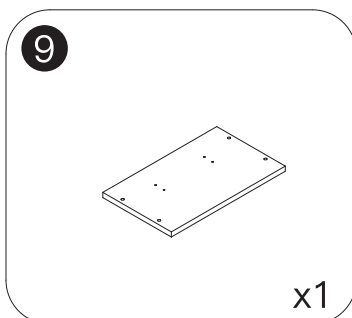
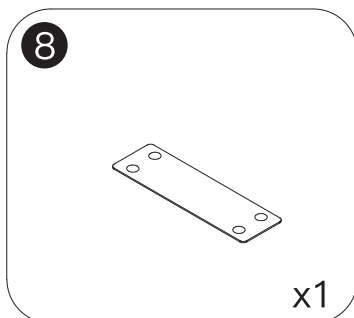
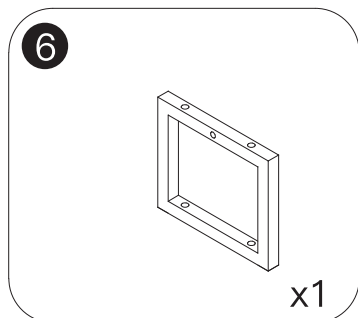

NOTICE:

(1) Please ensure that the side of part 9 with a shorter distance between the hole and the edge is placed as shown.

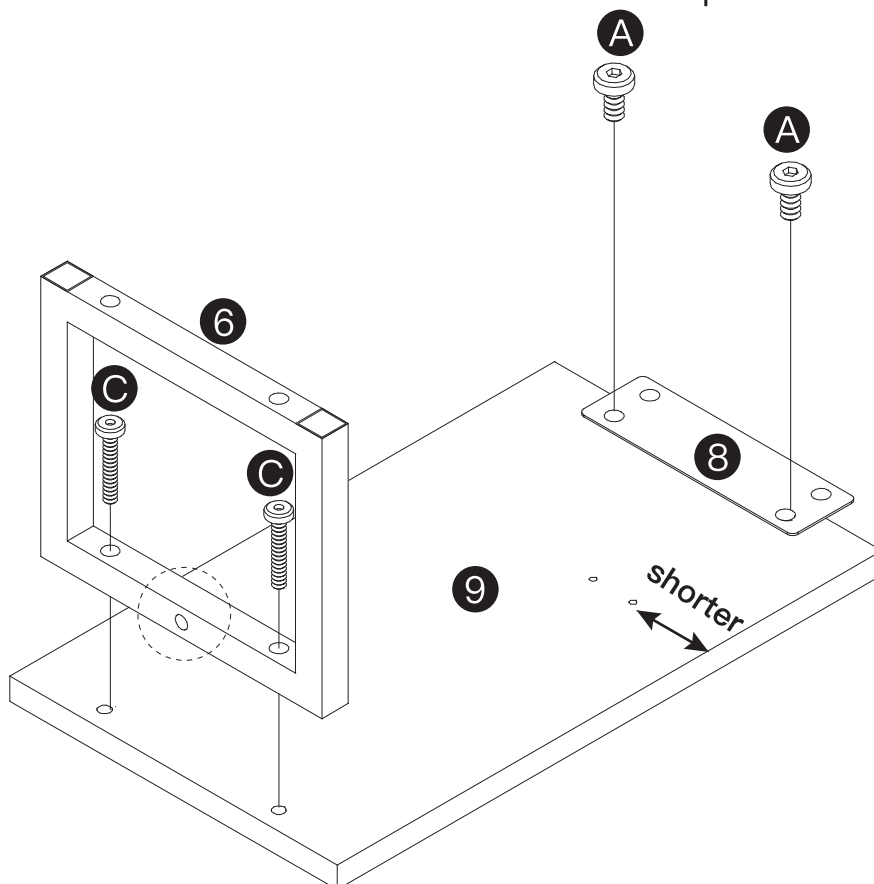

(2) Please ensure that the hole of part 6 is located below.

STEP 15

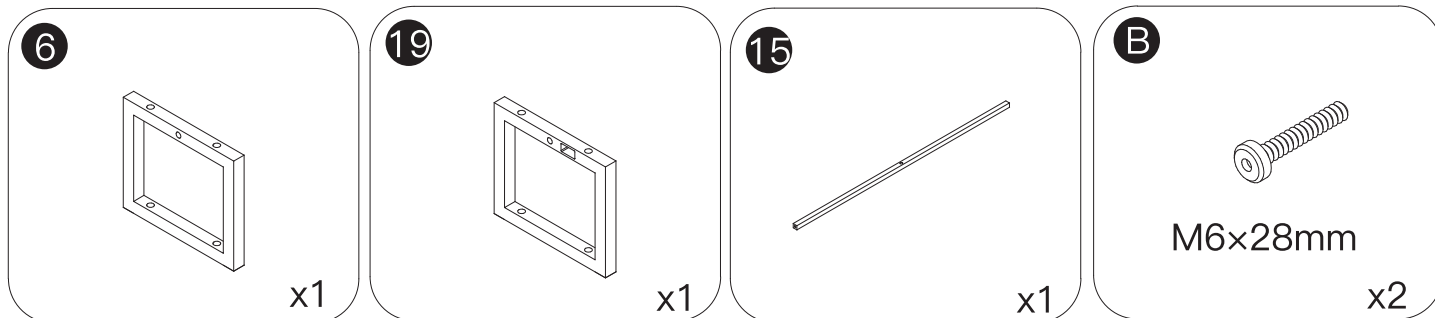

NOTICE:

(1) Please ensure that the hole of part 15 is facing upwards.

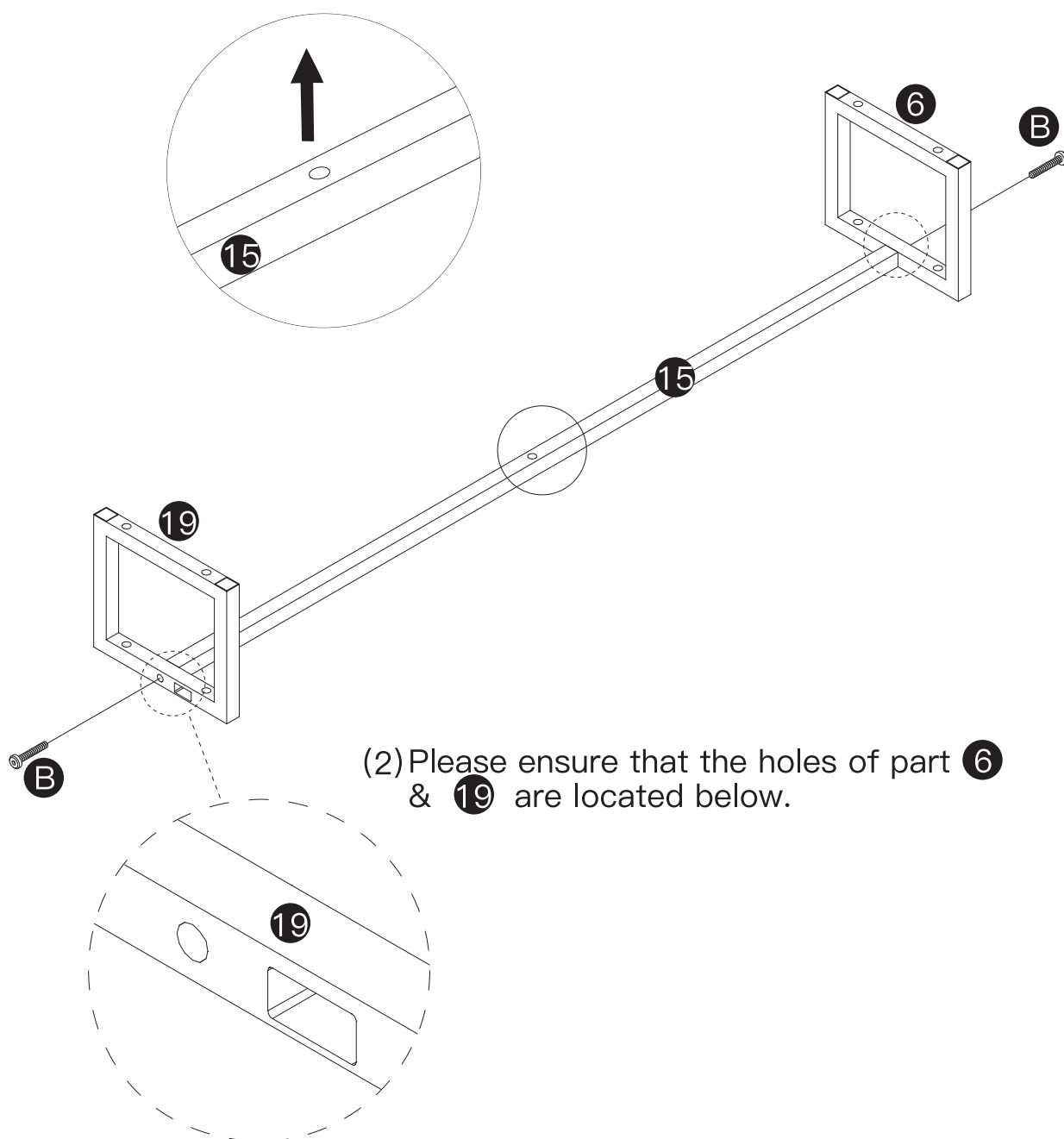

STEP 16

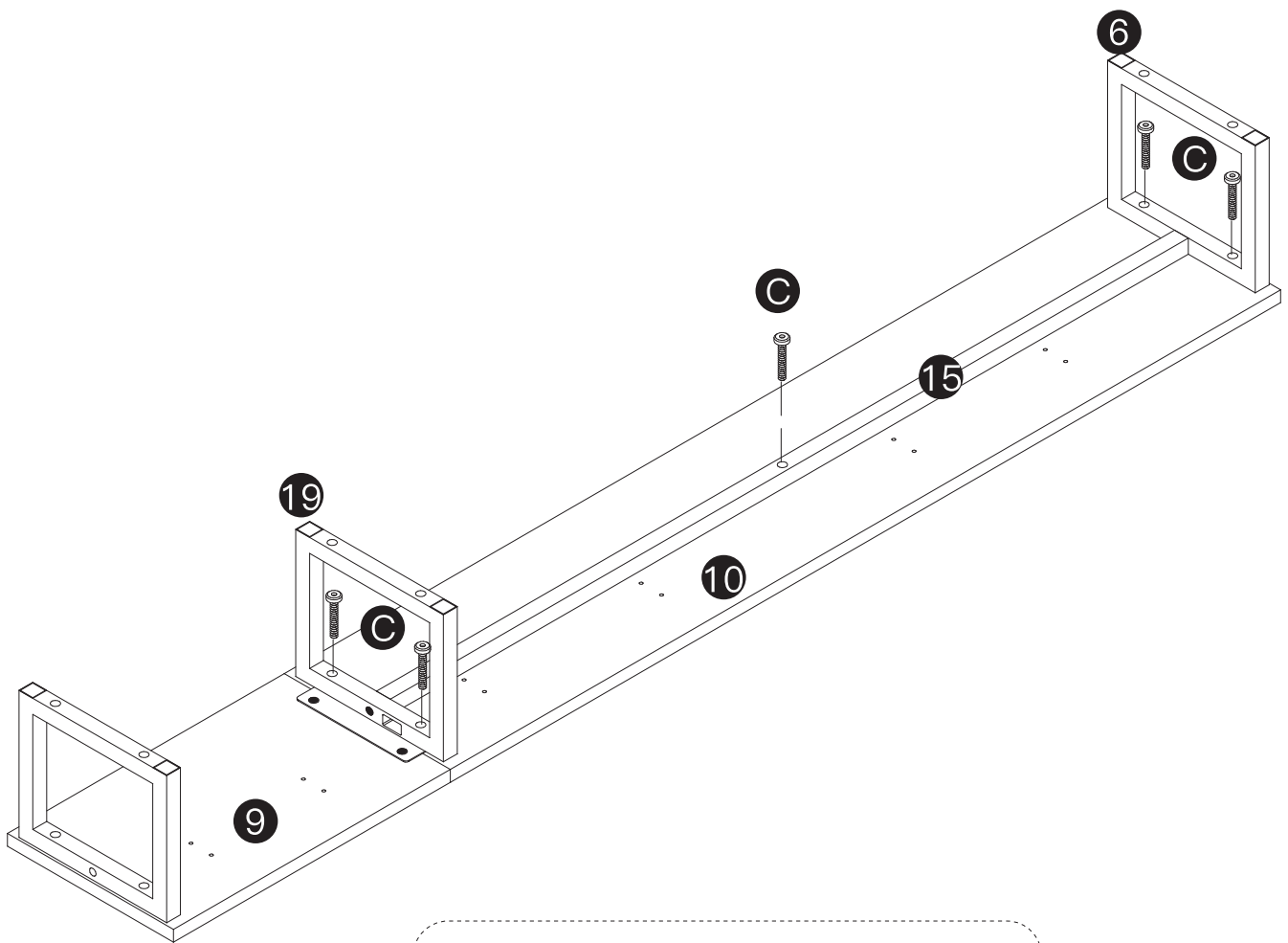
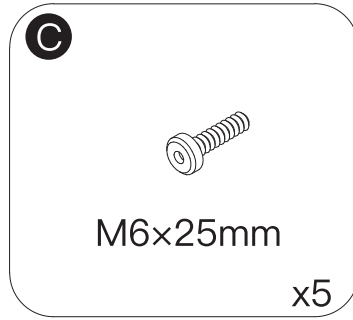
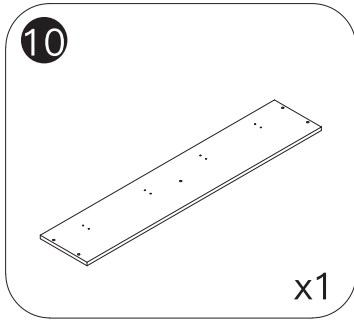

NOTICE:

Please ensure that the reserved holes for the light strips of part 9 & 10 are on the same side.

STEP 17

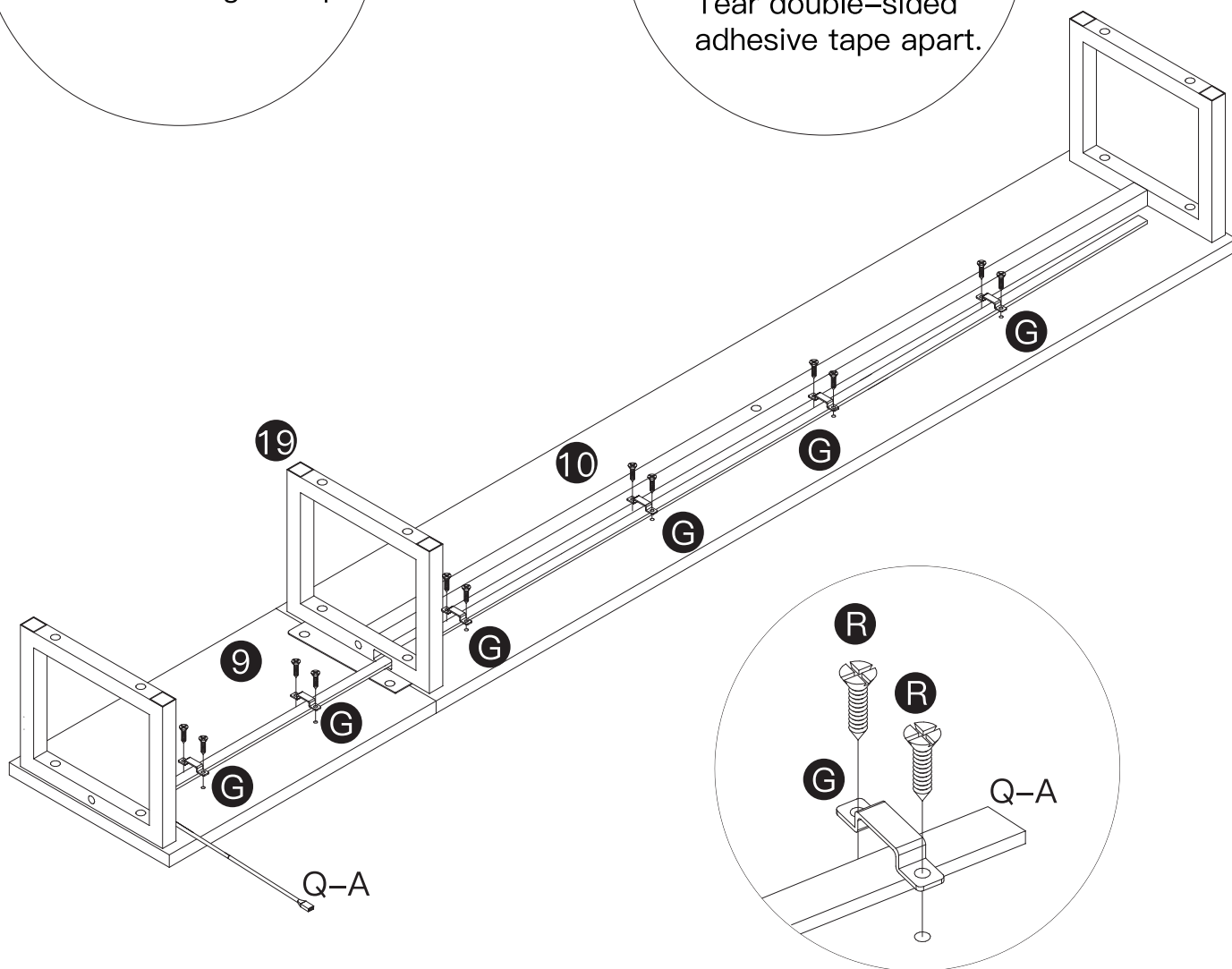
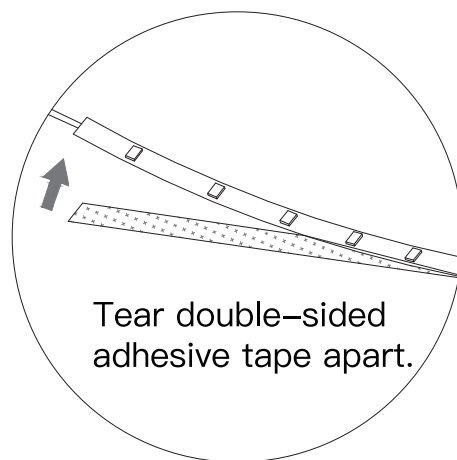
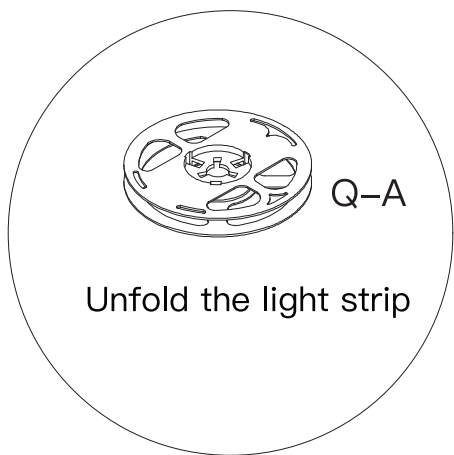
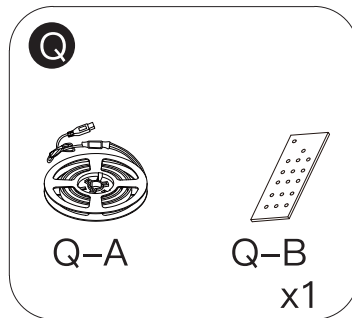
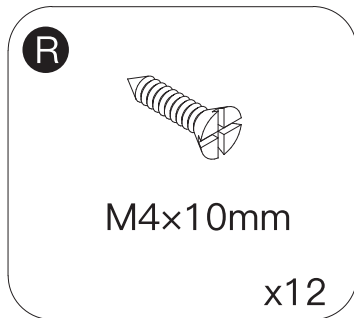
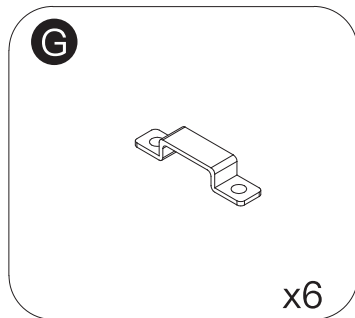

STEP 18

C



M6x25mm

x6

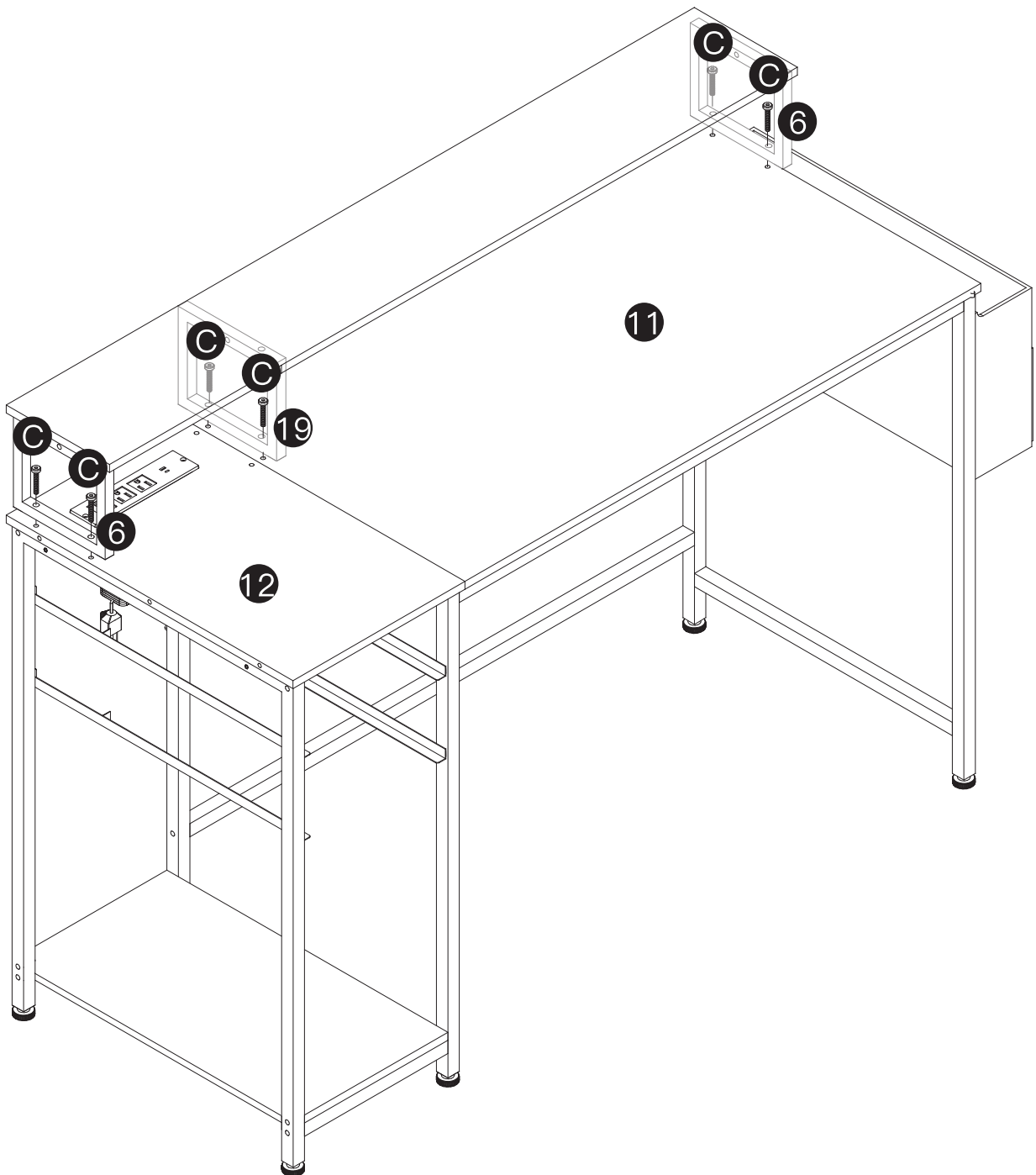

STEP 19

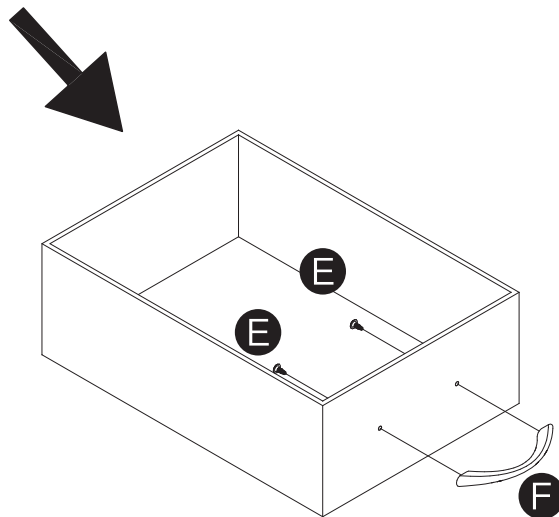
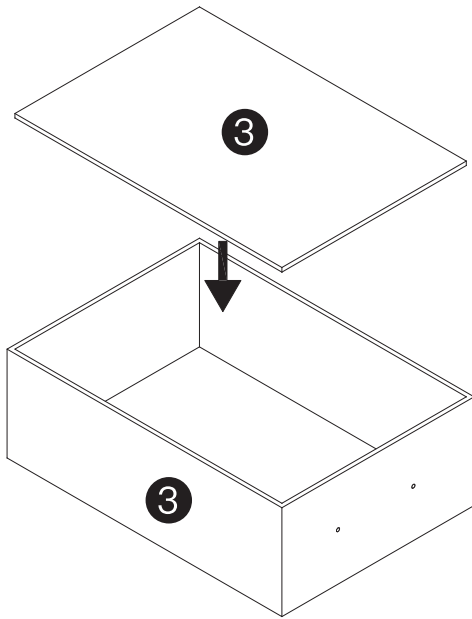
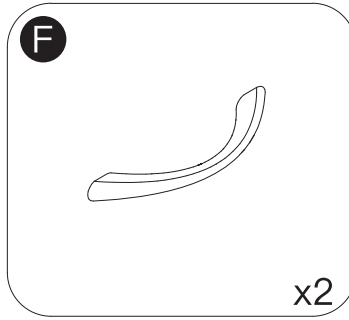
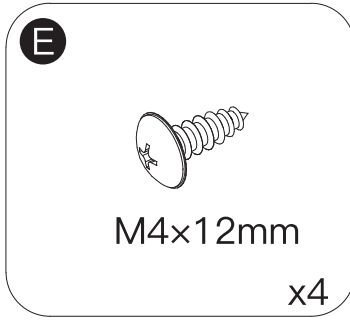
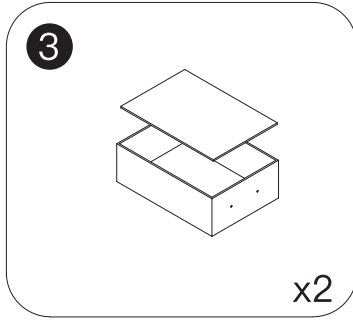

x2

STEP 20

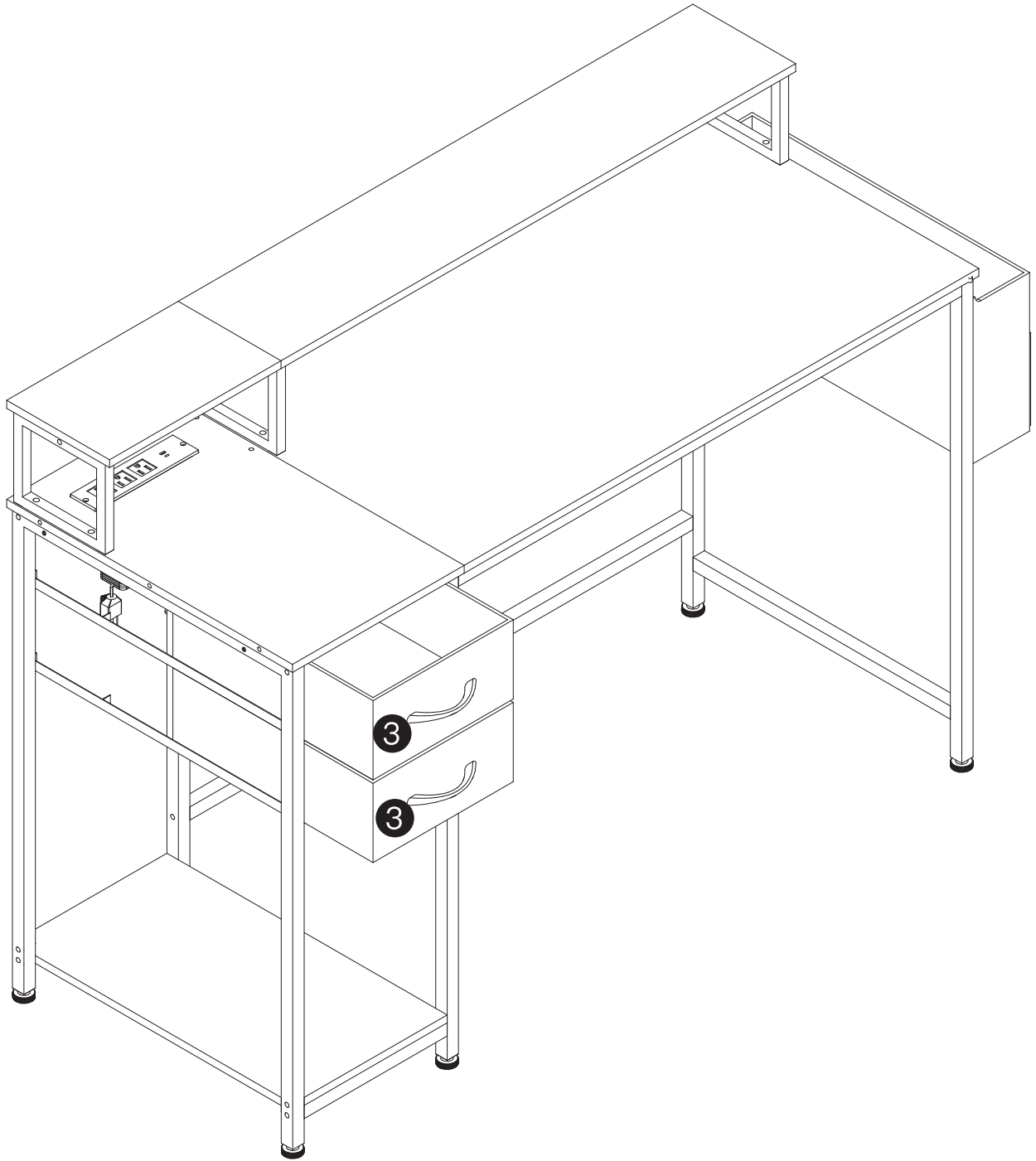

STEP 21

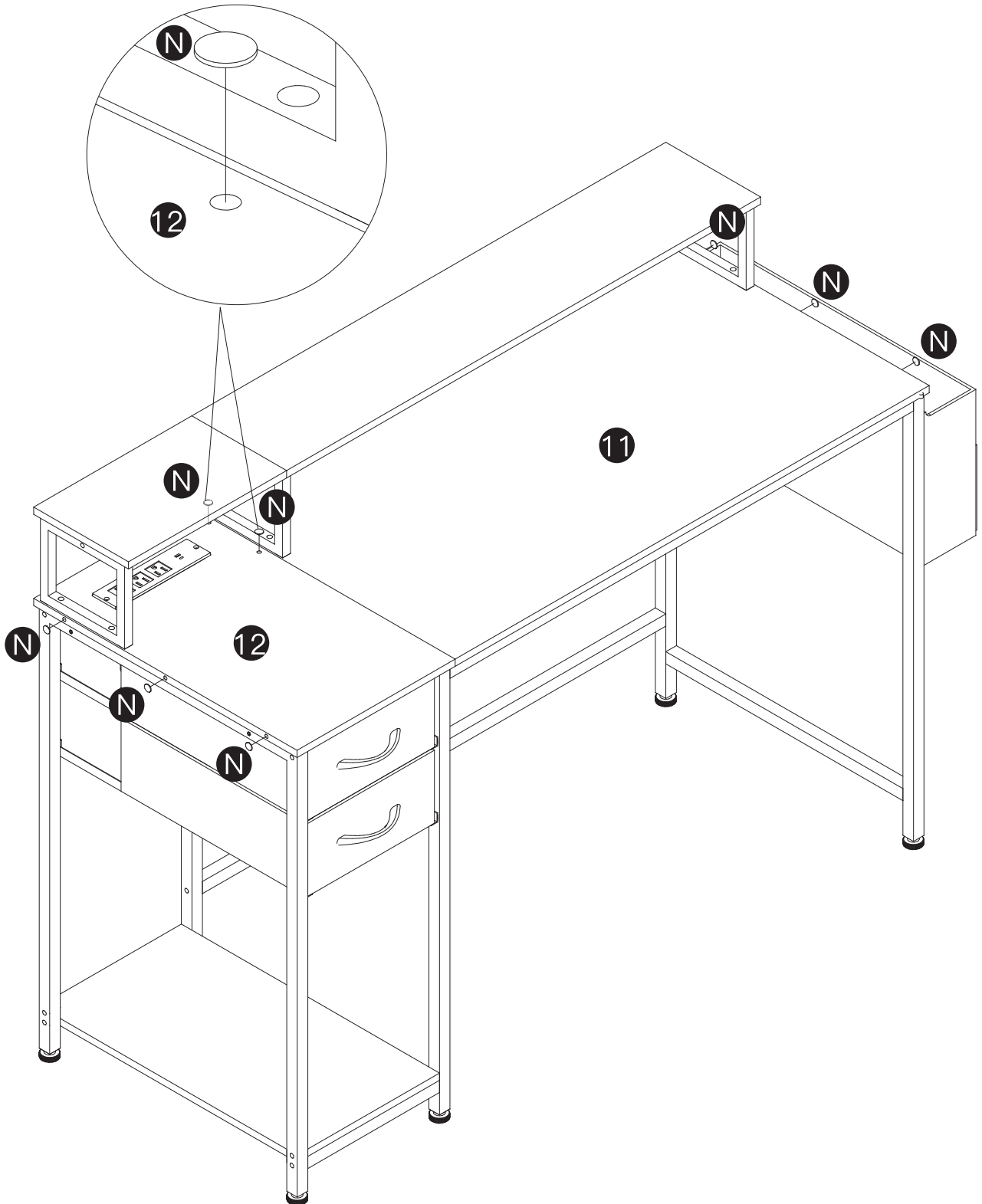
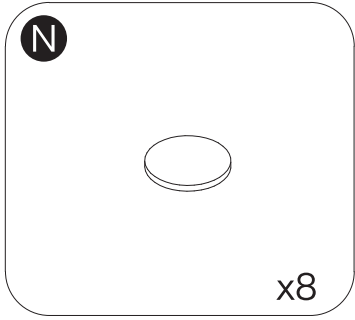

STEP 22

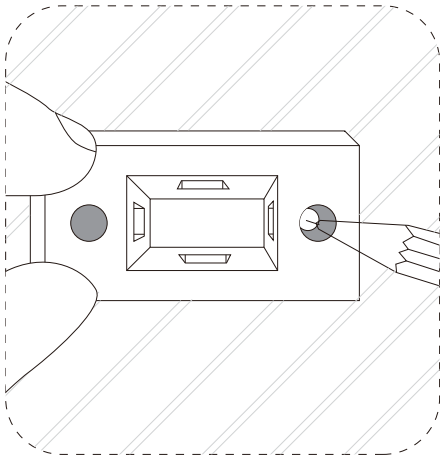
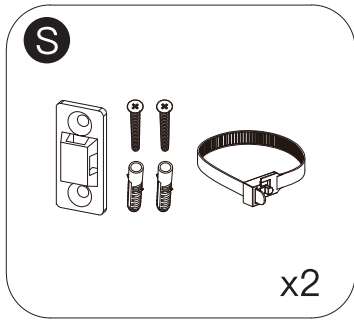

(1) Mark the location of bolt hole.

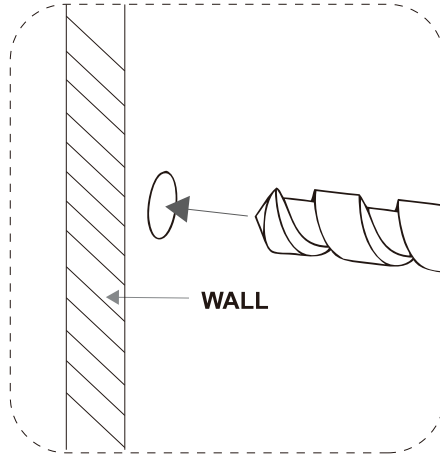

(2) Drill holes at marked location.

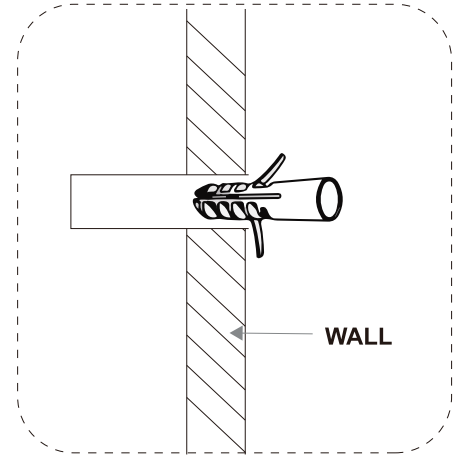

(3) Press the protective bolts in the wall.

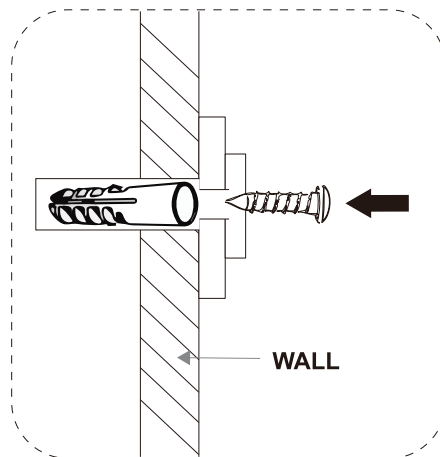

(4) Fix the safety lock on the wall with bolts.

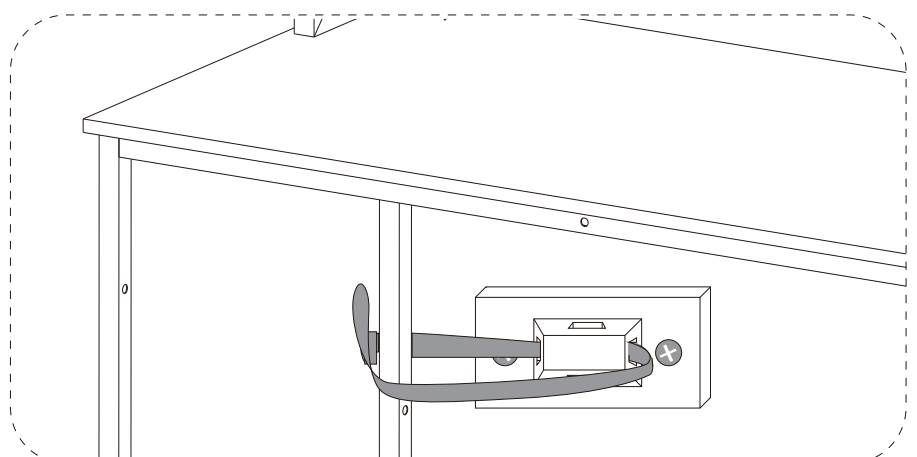

(5) Get the safety belts cross the lock and product, then get fastened.

TYPE-B INSTALLATION

EXPLODED DRAWING:

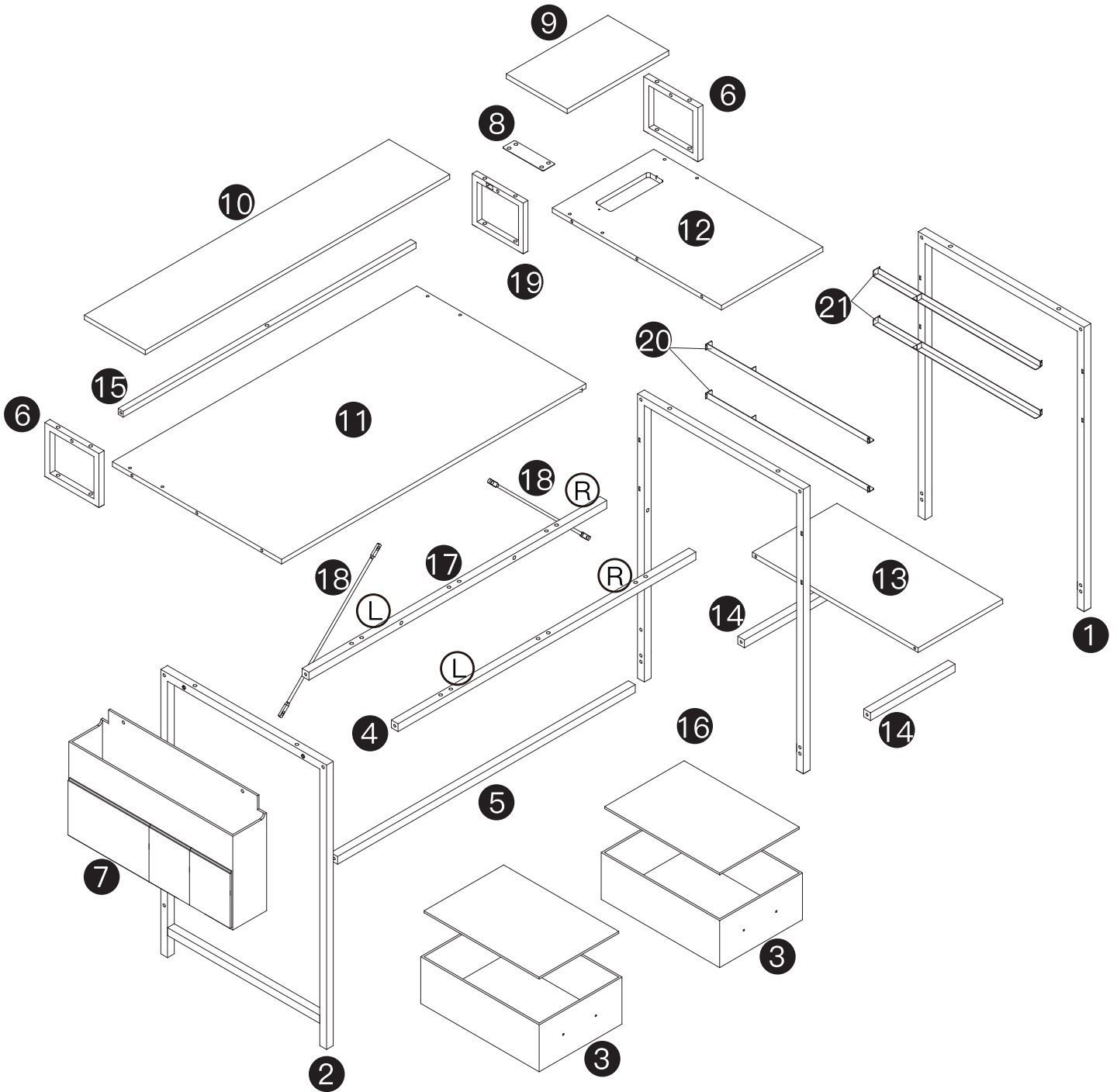

STEP 1

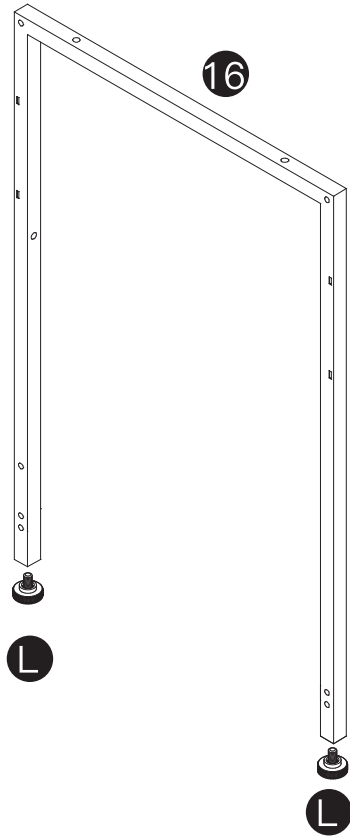
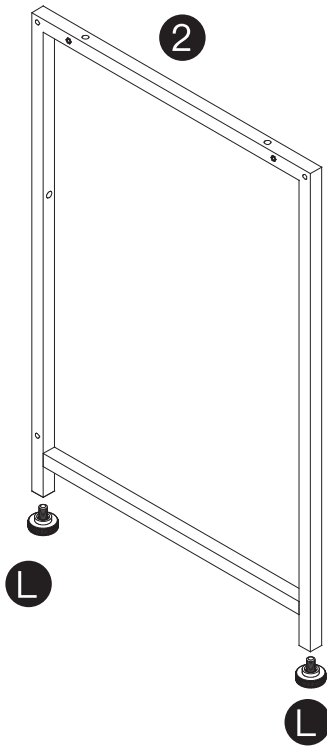
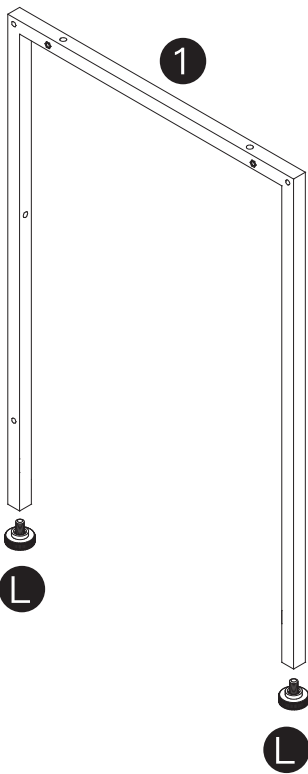
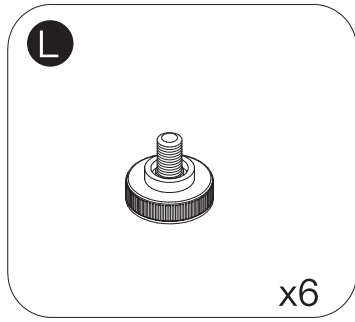
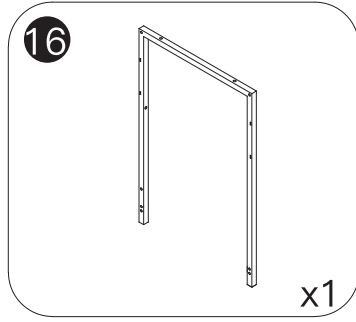
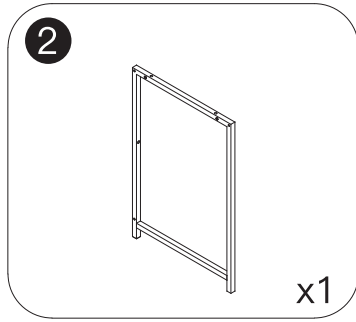
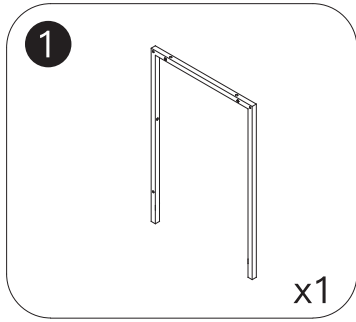

STEP 2

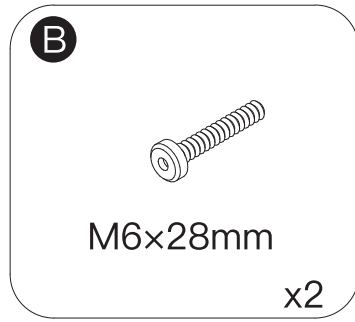
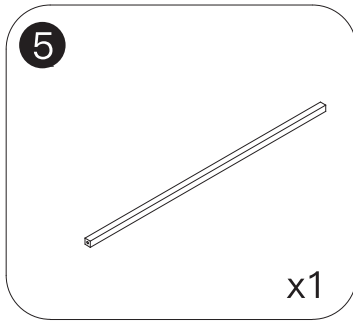

NOTICE:

Please ensure that the hole of part 2 & 16 is facing upwards.

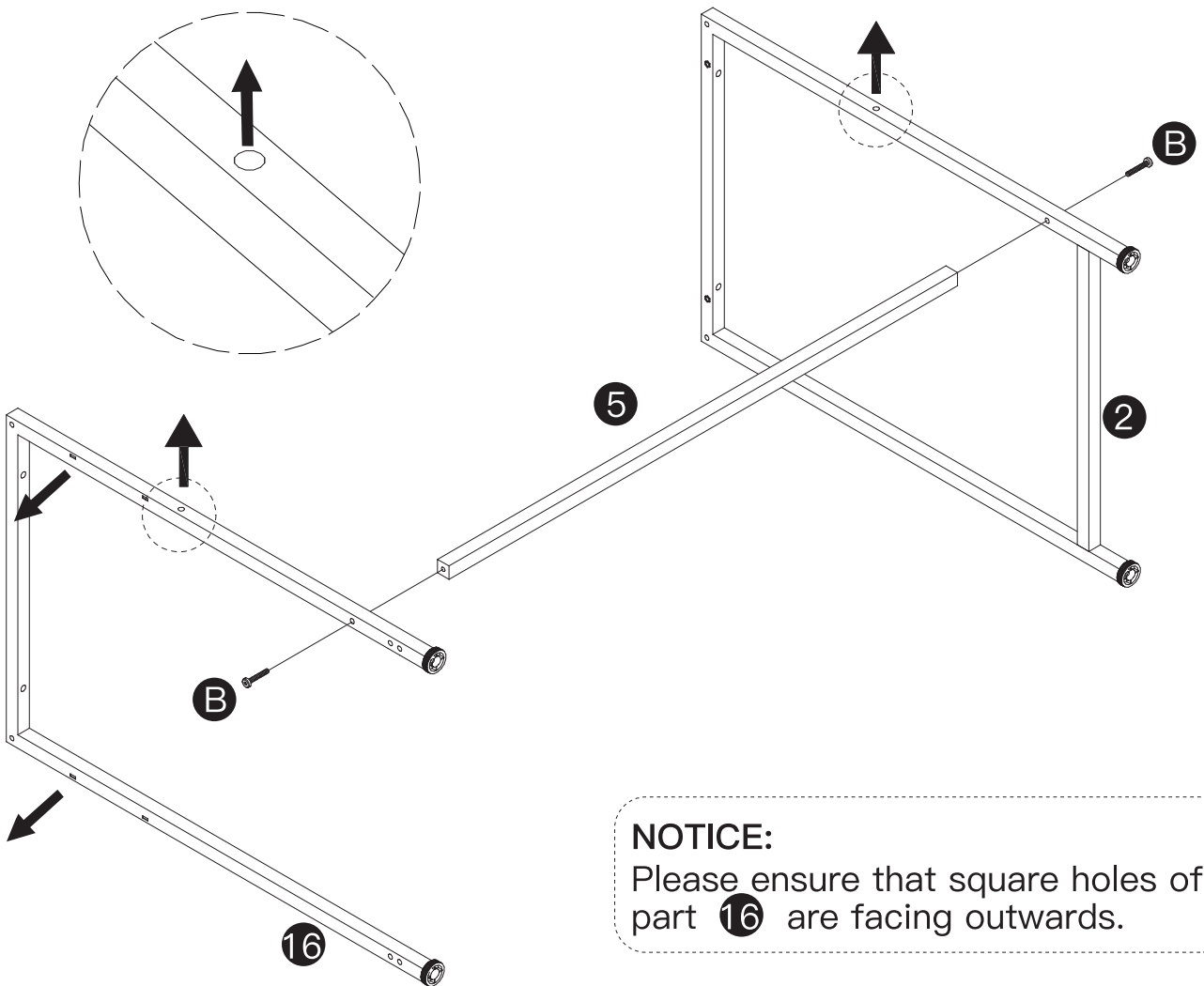

NOTICE:

Please ensure that square holes of part 16 are facing outwards.

STEP 3

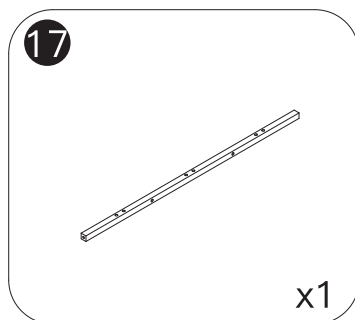
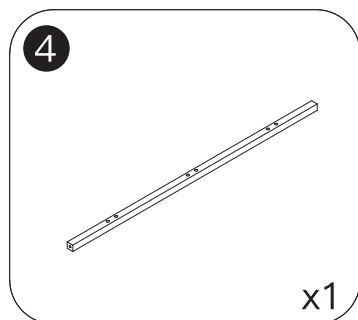

NOTICE:

(1) Please distinguish **L** and **R** on part **4** and **17** by the distance between the middle hole and the edge before installation.

(2) Please ensure that the side with 2 holes of part **17** is facing upwards.

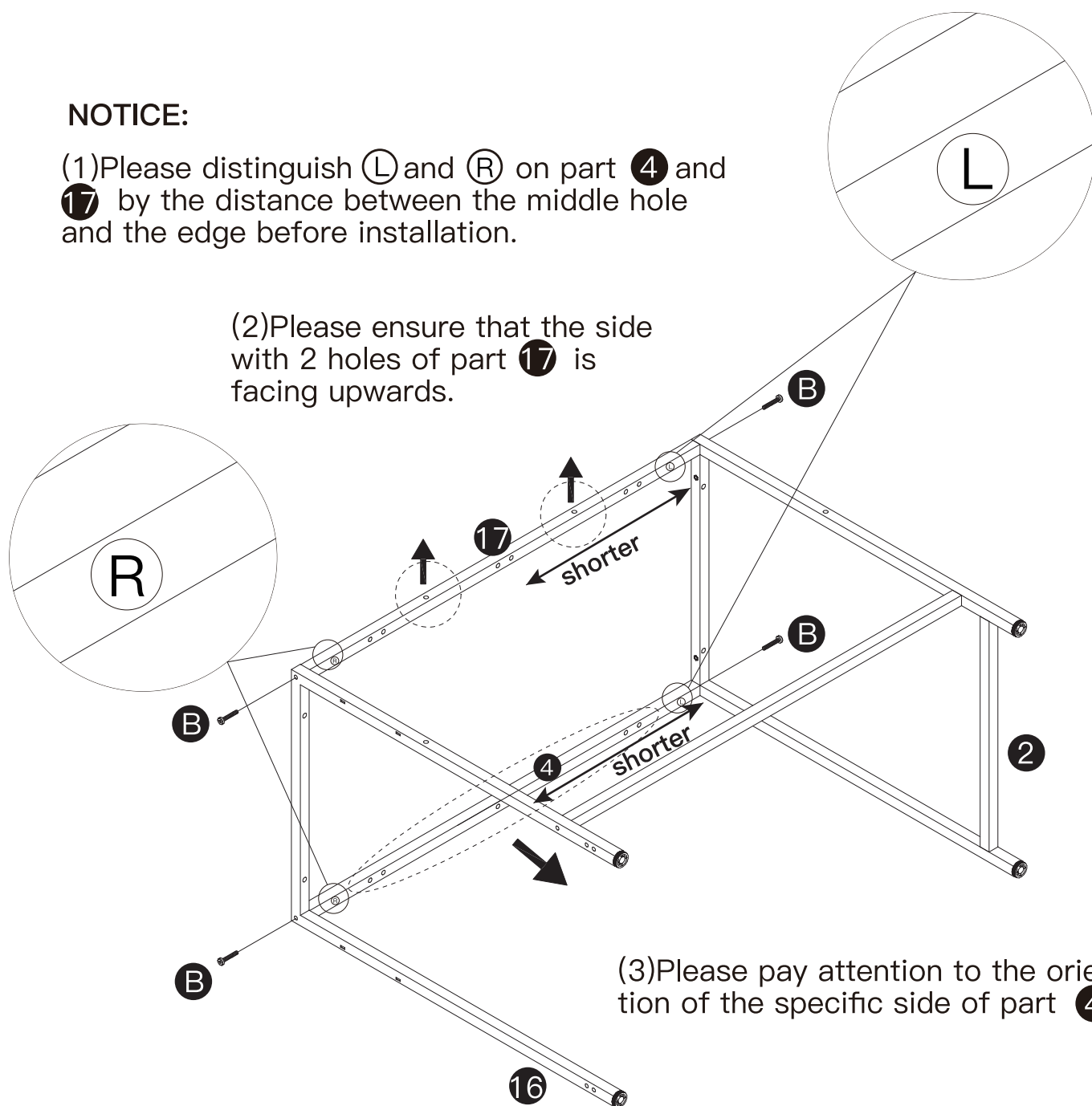

(3) Please pay attention to the orientation of the specific side of part **4**.

STEP 4

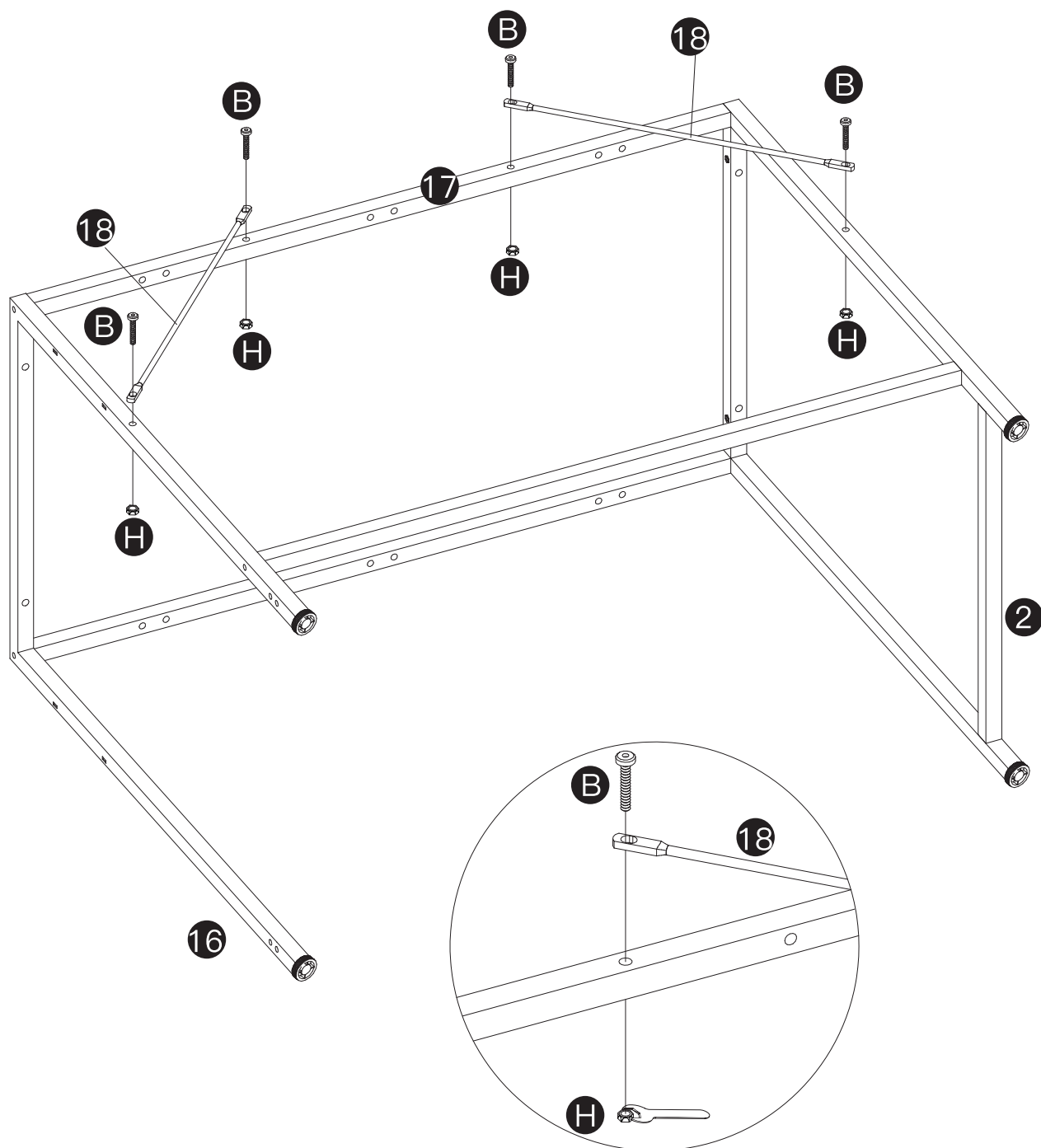
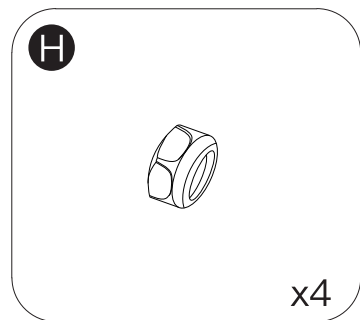
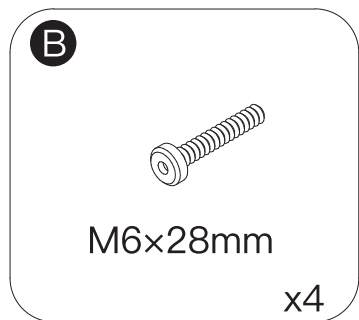
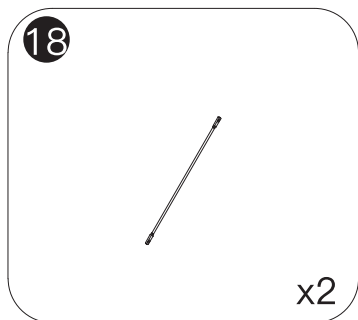

STEP 5

14

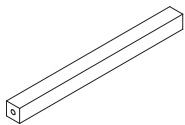

x2

B

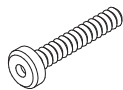

M6x28mm

x2

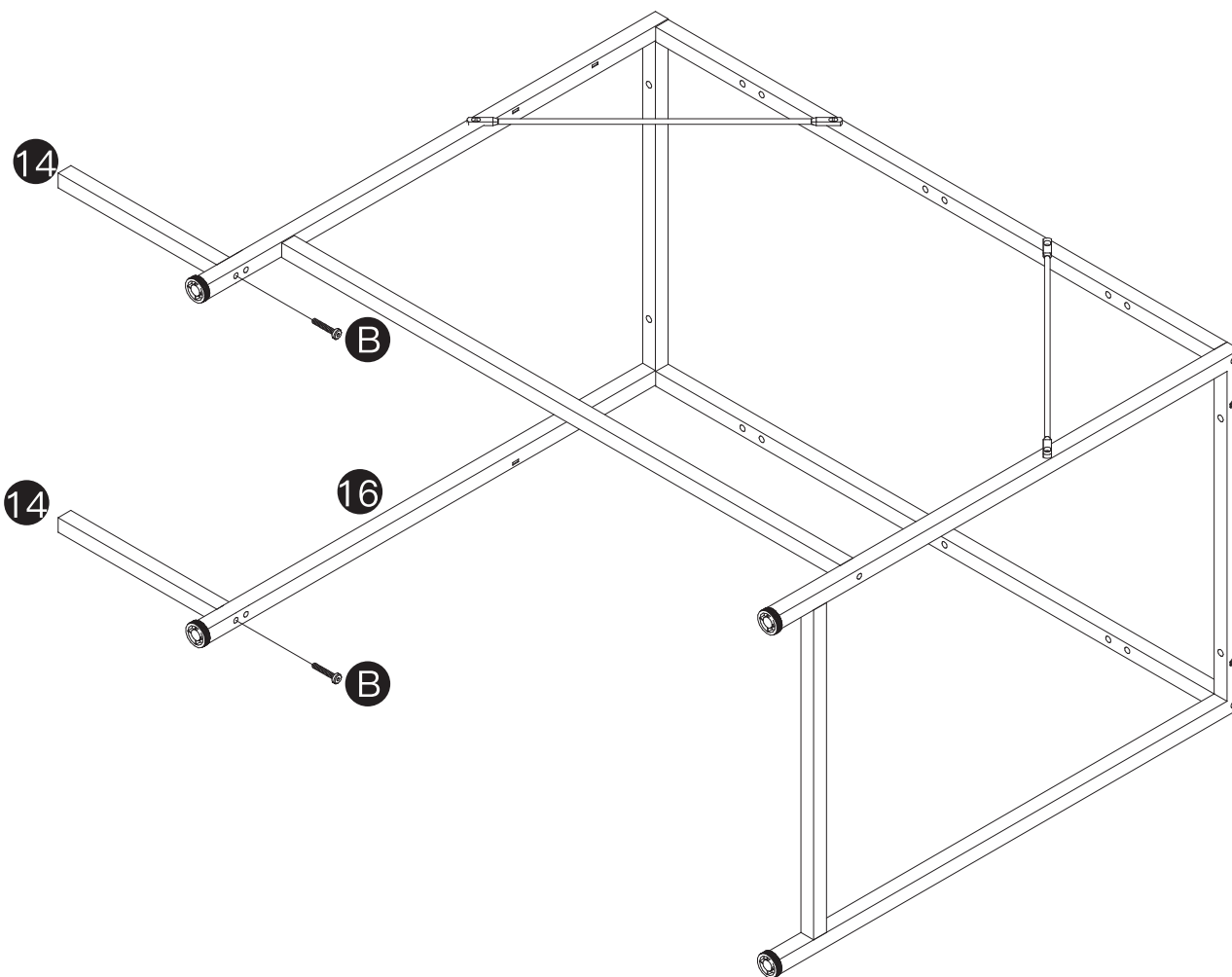

STEP 6

13

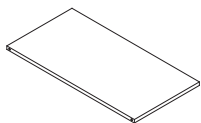

x1

D

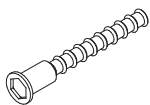

M5x48mm

x2

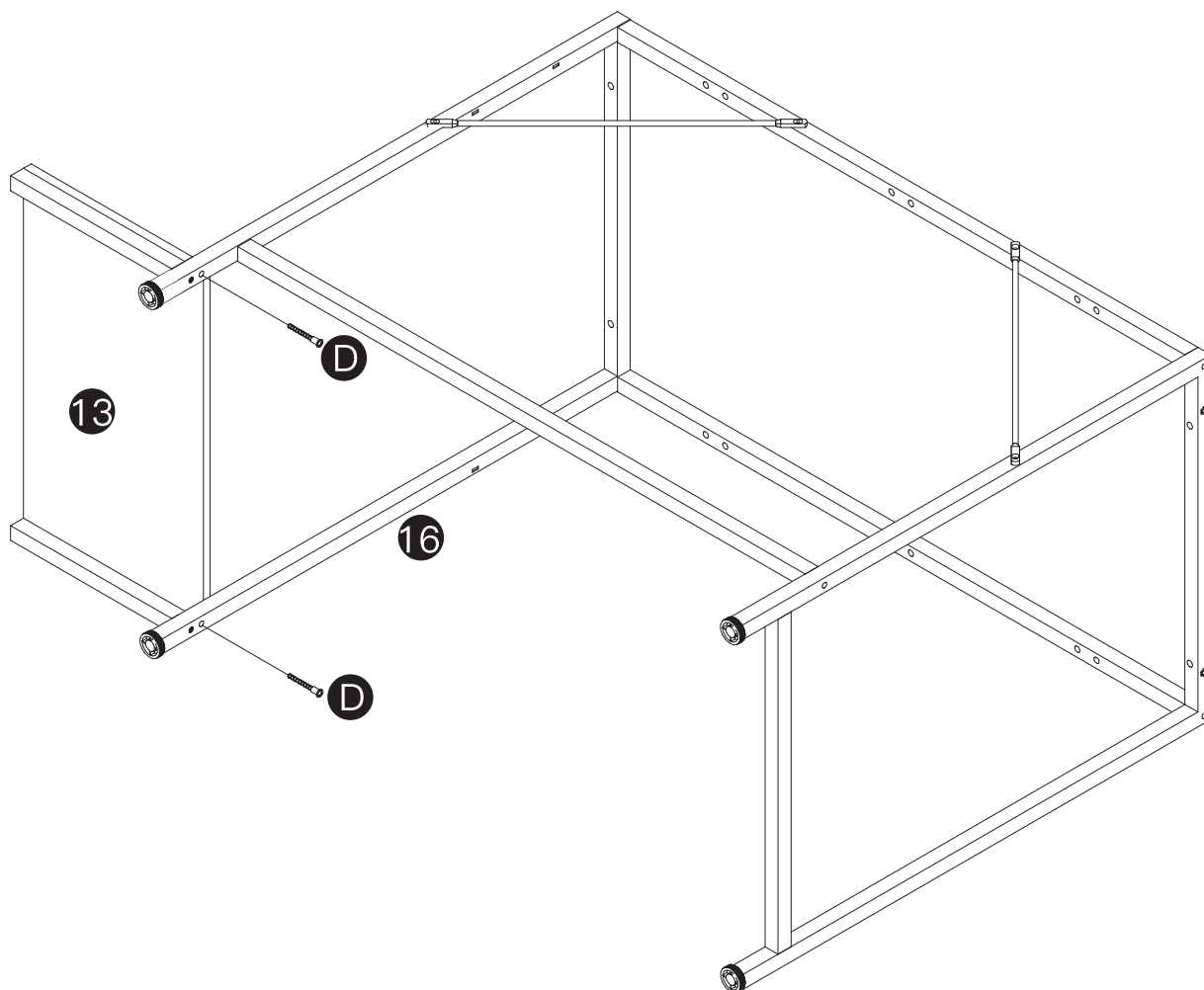

STEP 7

B

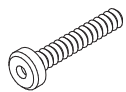

M6x28mm

x2

D

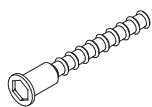

M5x48mm

x2

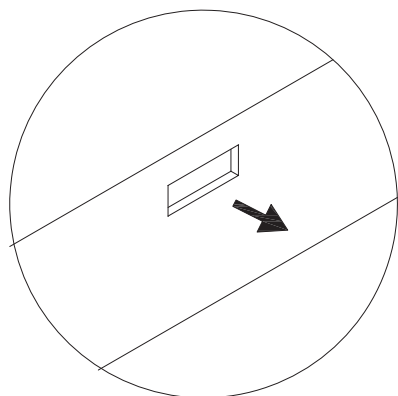

NOTICE:

Please ensure that square holes of part **1** are facing inwards.

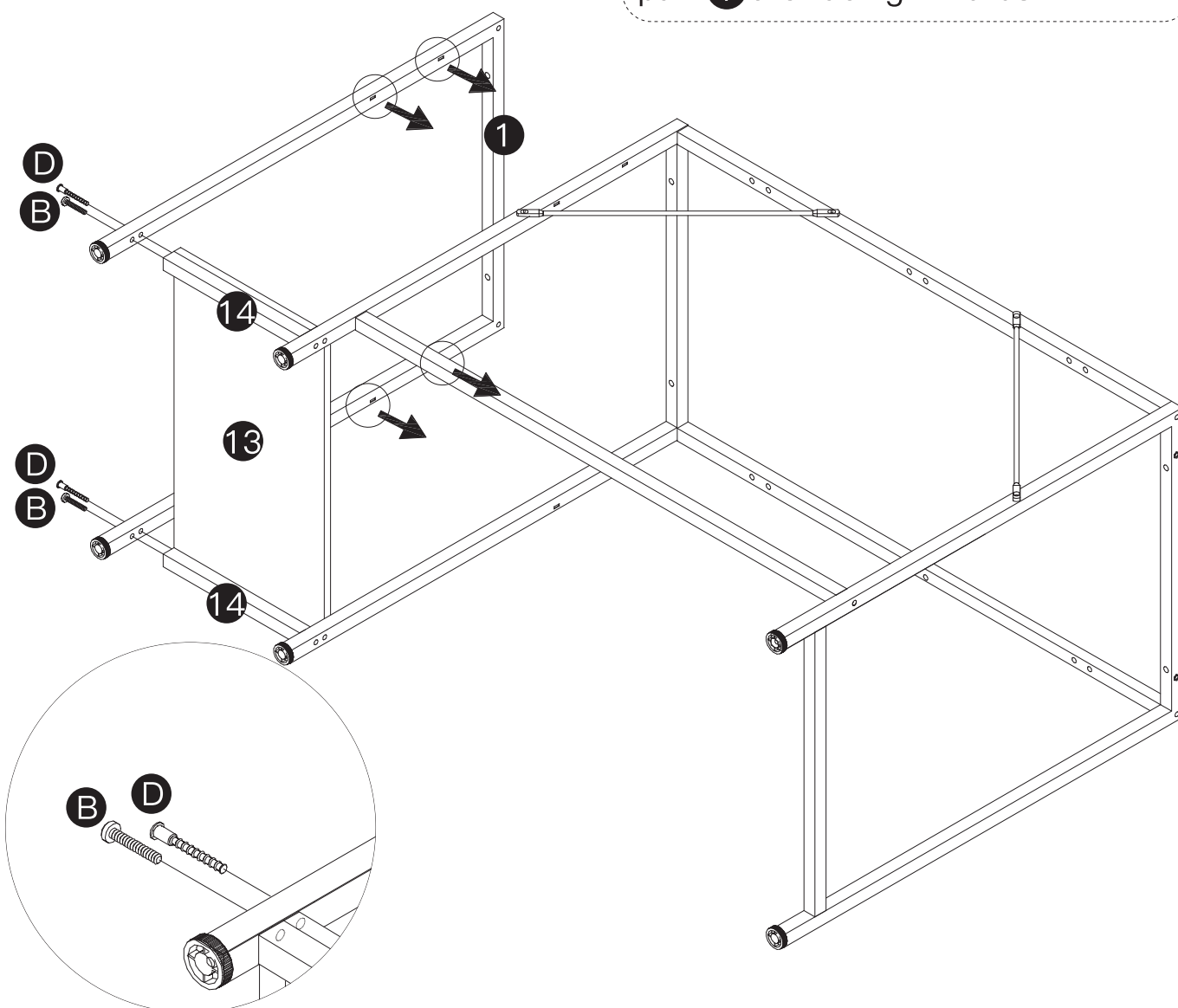

STEP 8

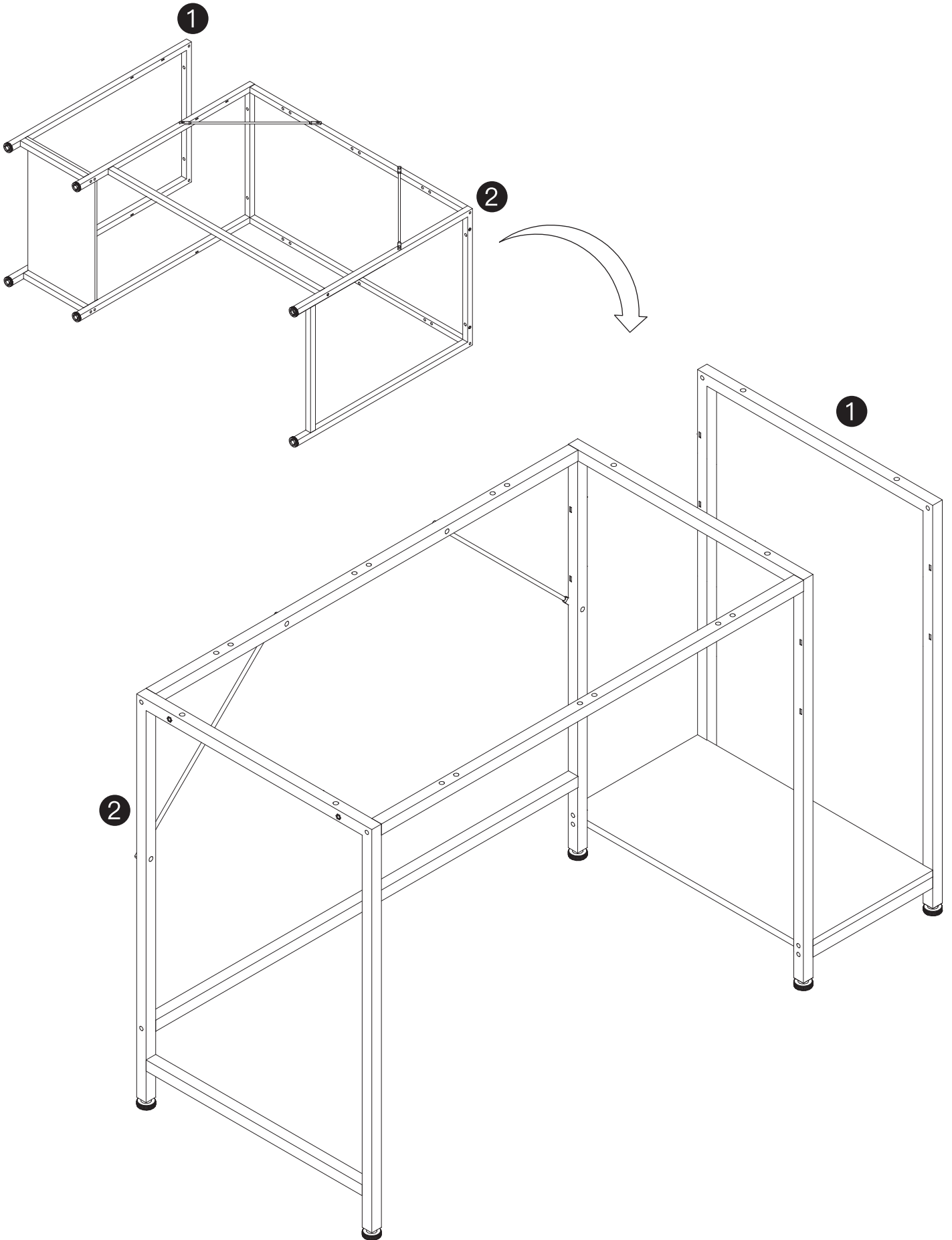

STEP 9

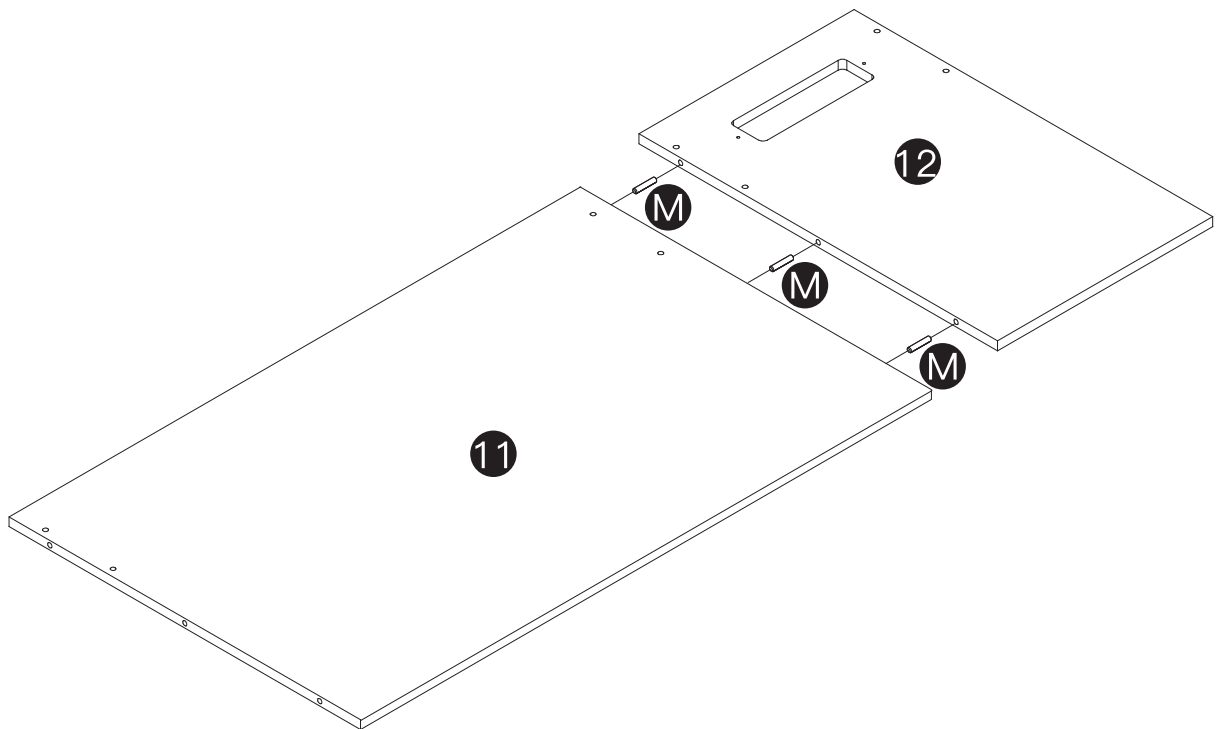
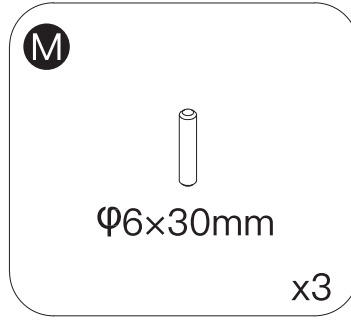
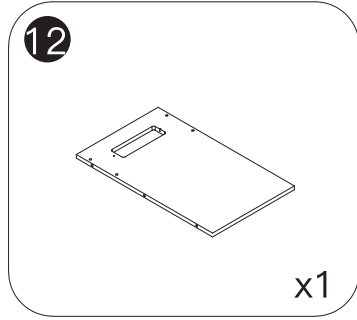
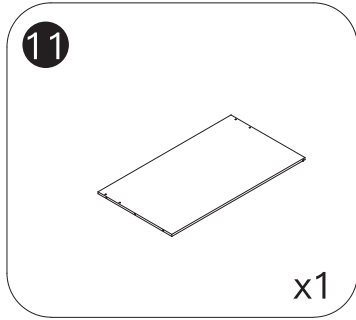

STEP 10

B

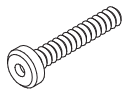

M6x28mm

x12

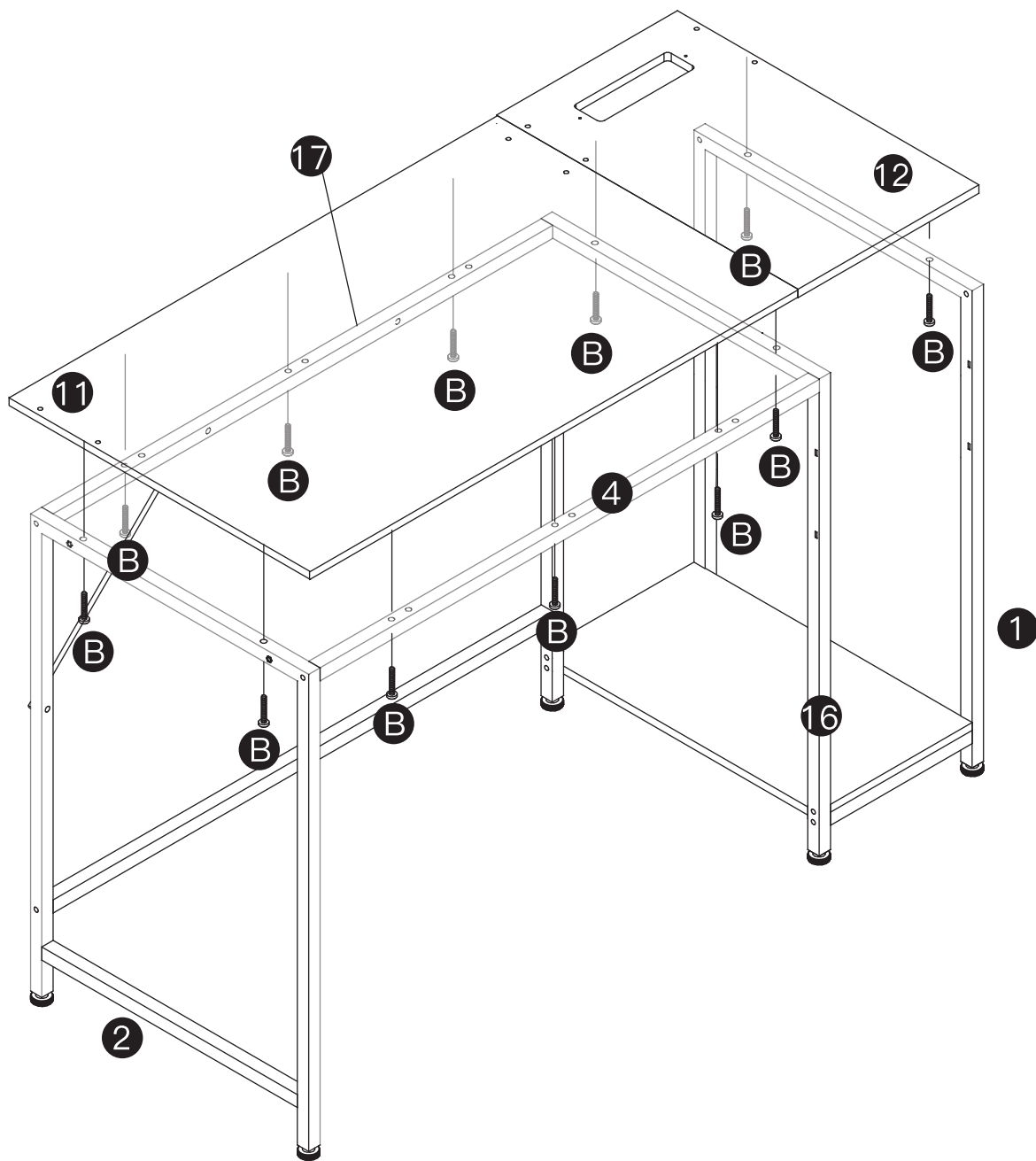

STEP 11

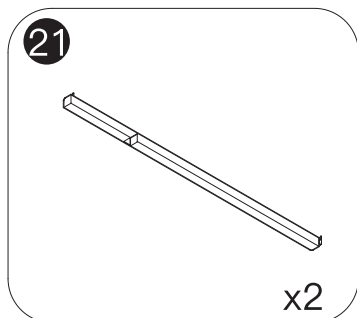
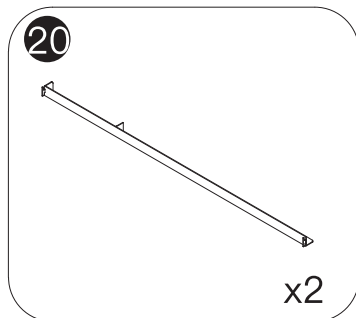

There's a corresponding L and R mark on each part located in a specified spot designed to distinguish them from each other easily.

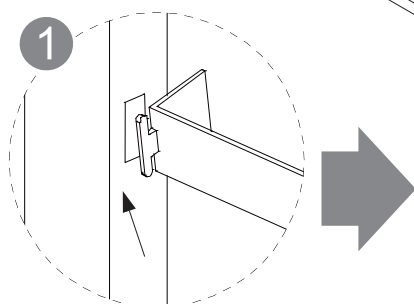
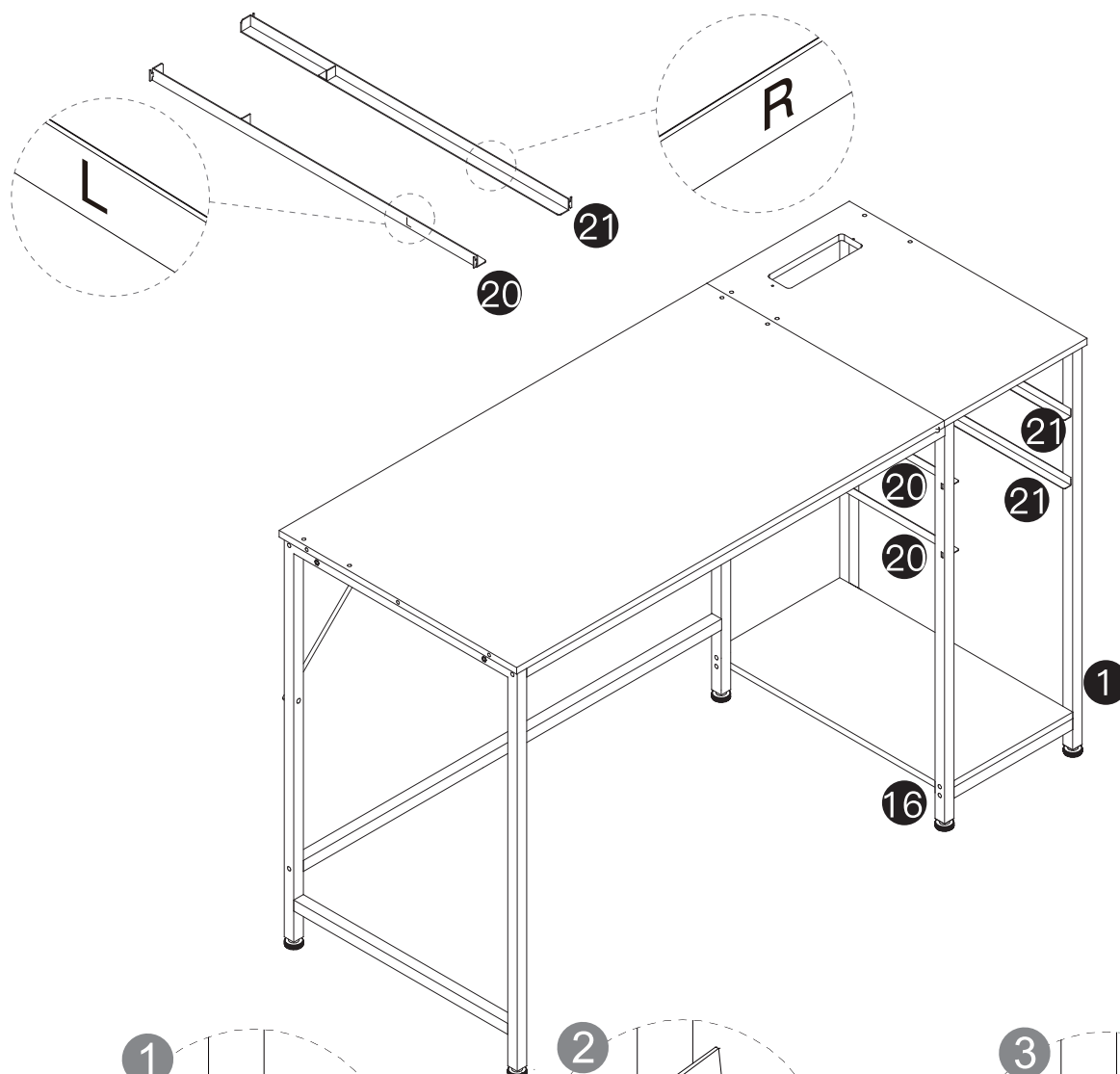

Insert the upper part into the square hole.

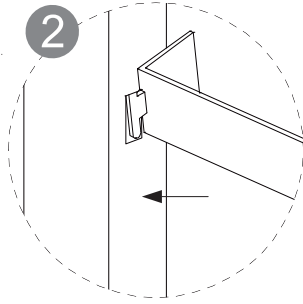

Then insert the rest part horizontally.

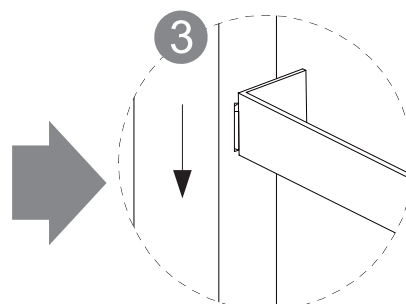

Press down the rail to ensure proper installation.

STEP 12

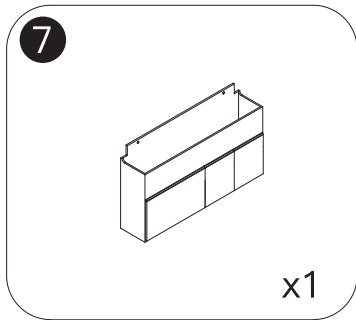

NOTICE:

Part 7 can be installed on either part 1 or part 2.

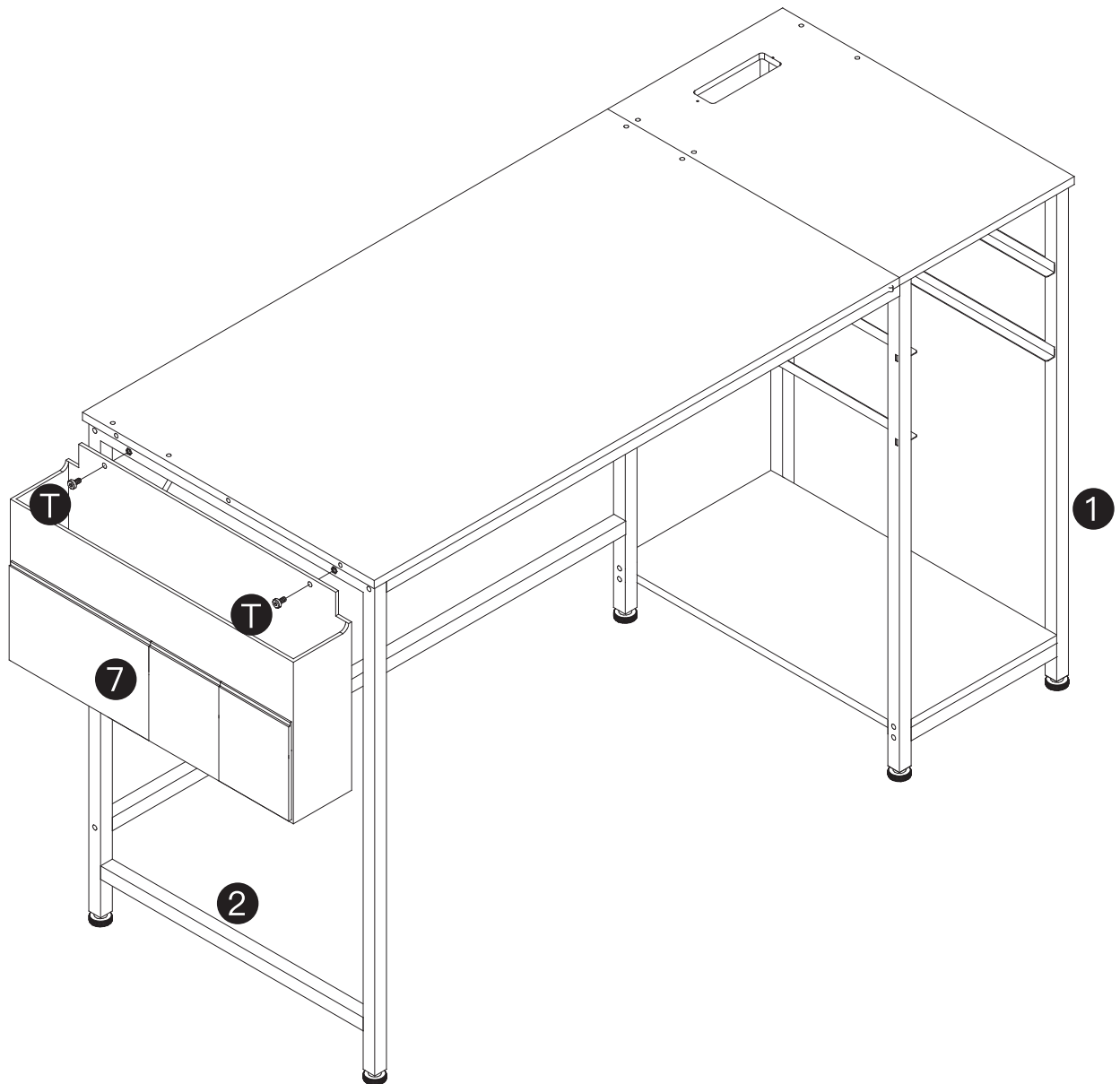

STEP 13

P

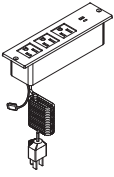

x1

R

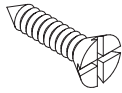

M4x10mm

x2

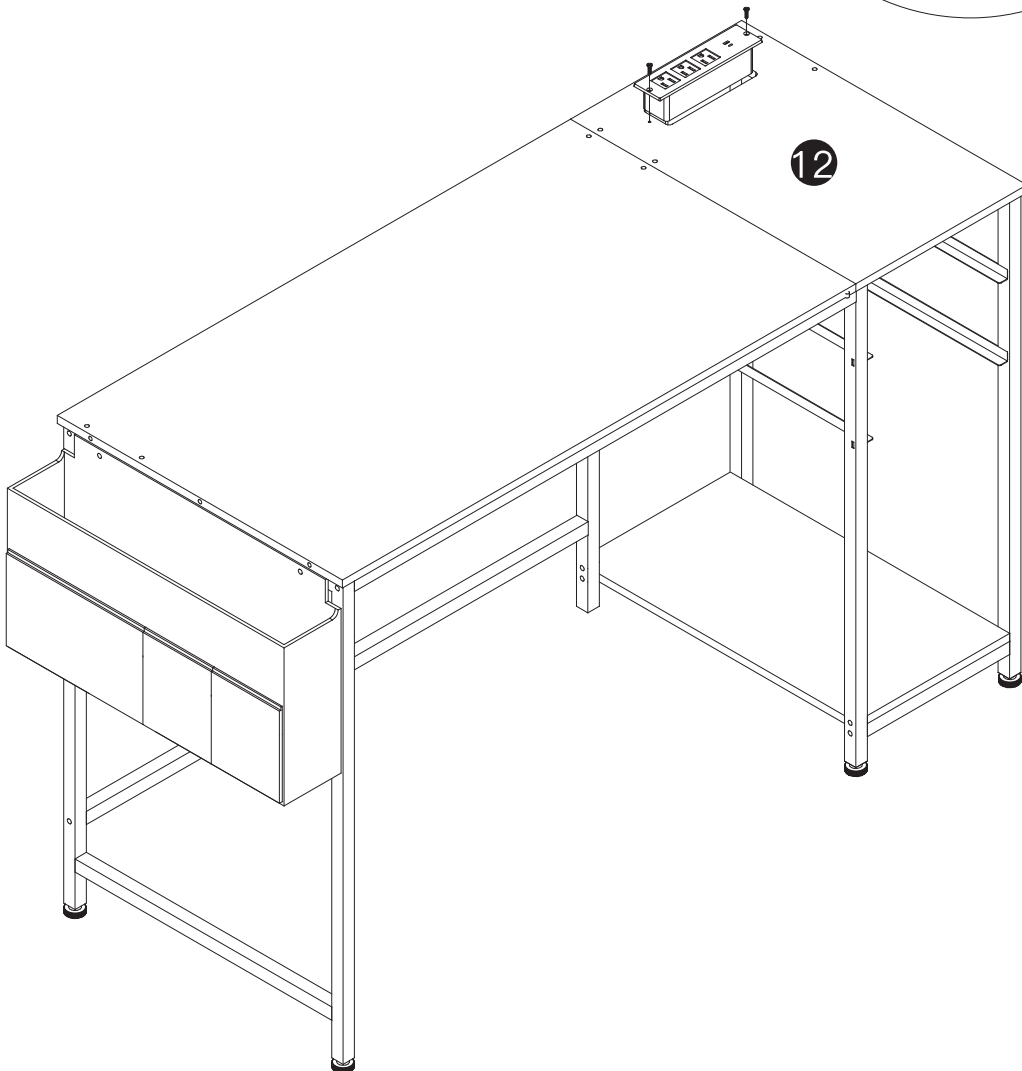
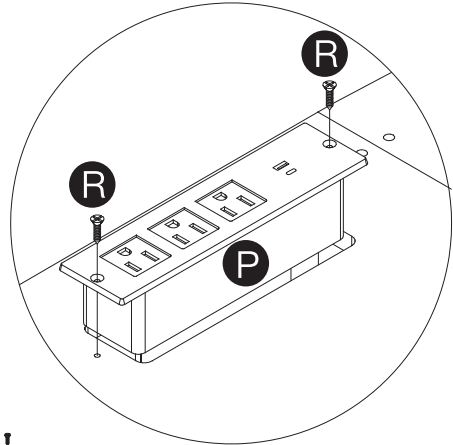

STEP 14

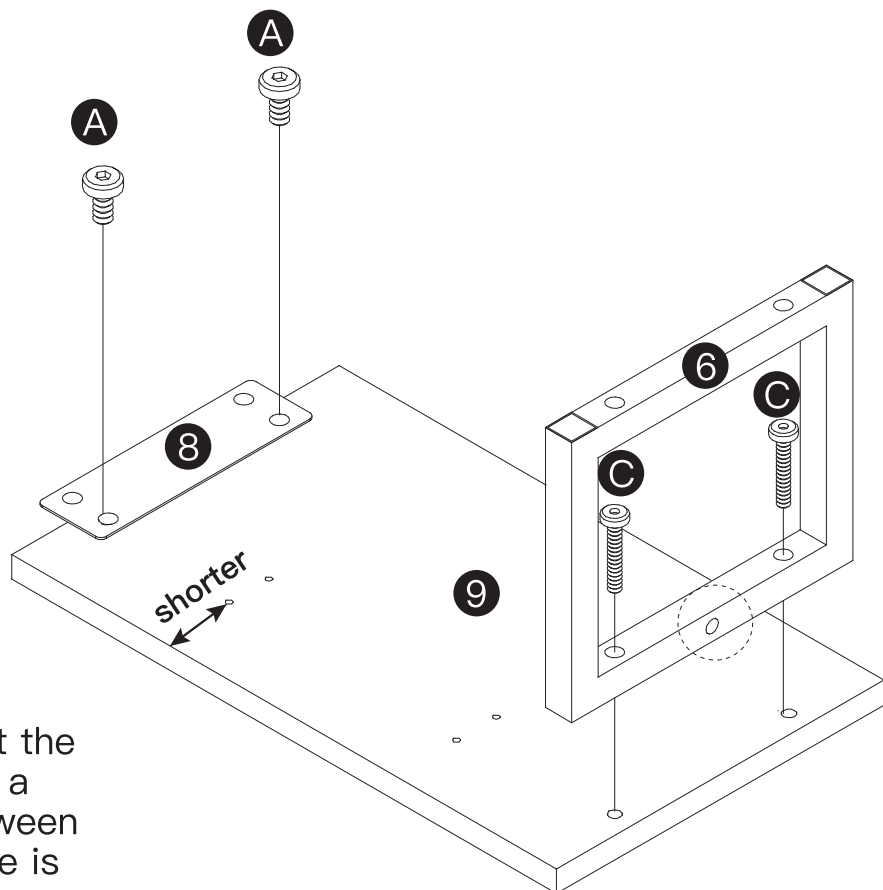
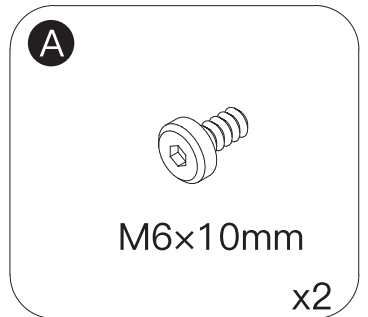
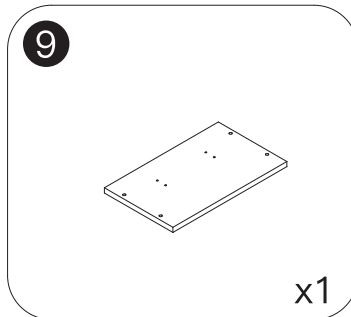
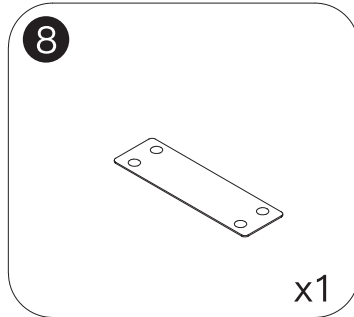
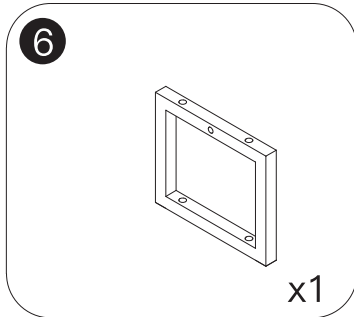

NOTICE:

(1) Please ensure that the side of part 9 with a shorter distance between the hole and the edge is placed as shown.

(2) Please ensure that the hole of part 6 is located below.

STEP 15

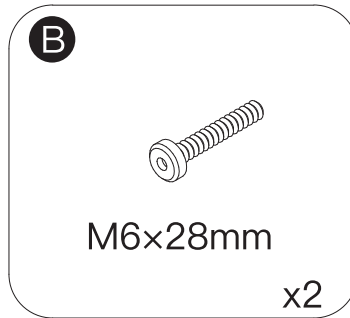
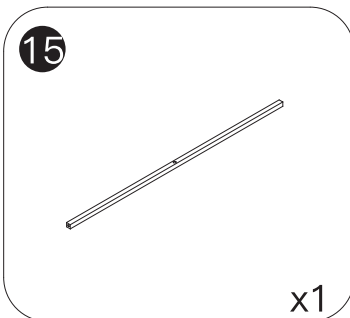
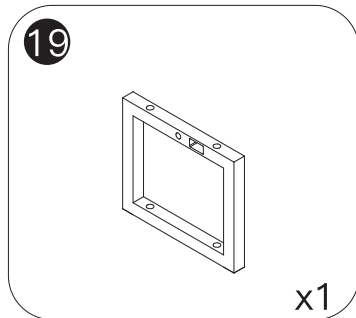
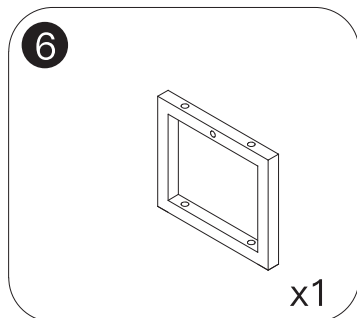

NOTICE:

(1) Please ensure that the hole of part 15 is facing upwards.

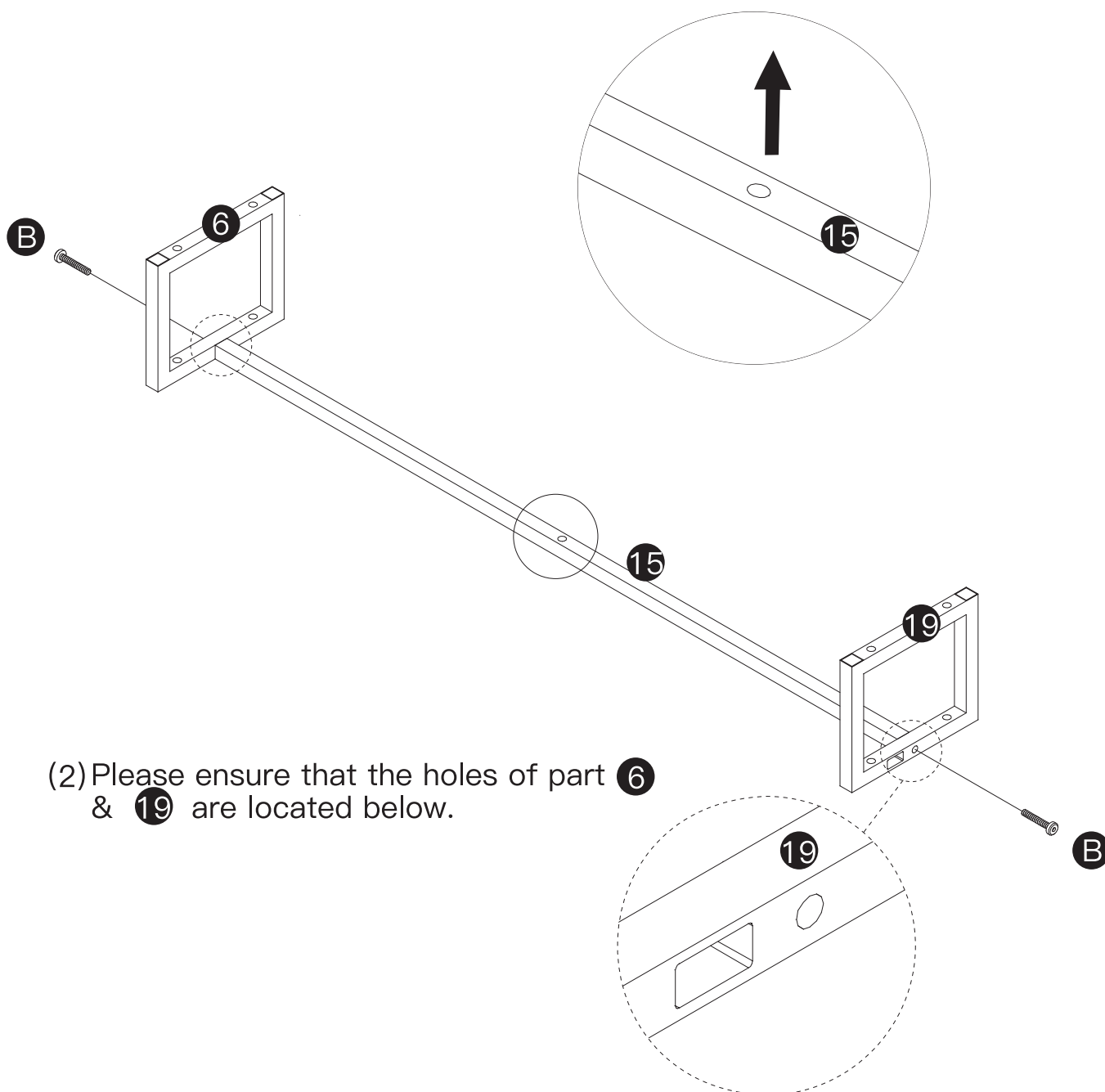

STEP 16

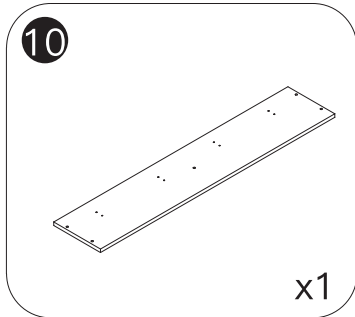

NOTICE:

Please ensure that the reserved holes for the light strips of part 9 & 10 are on the same side.

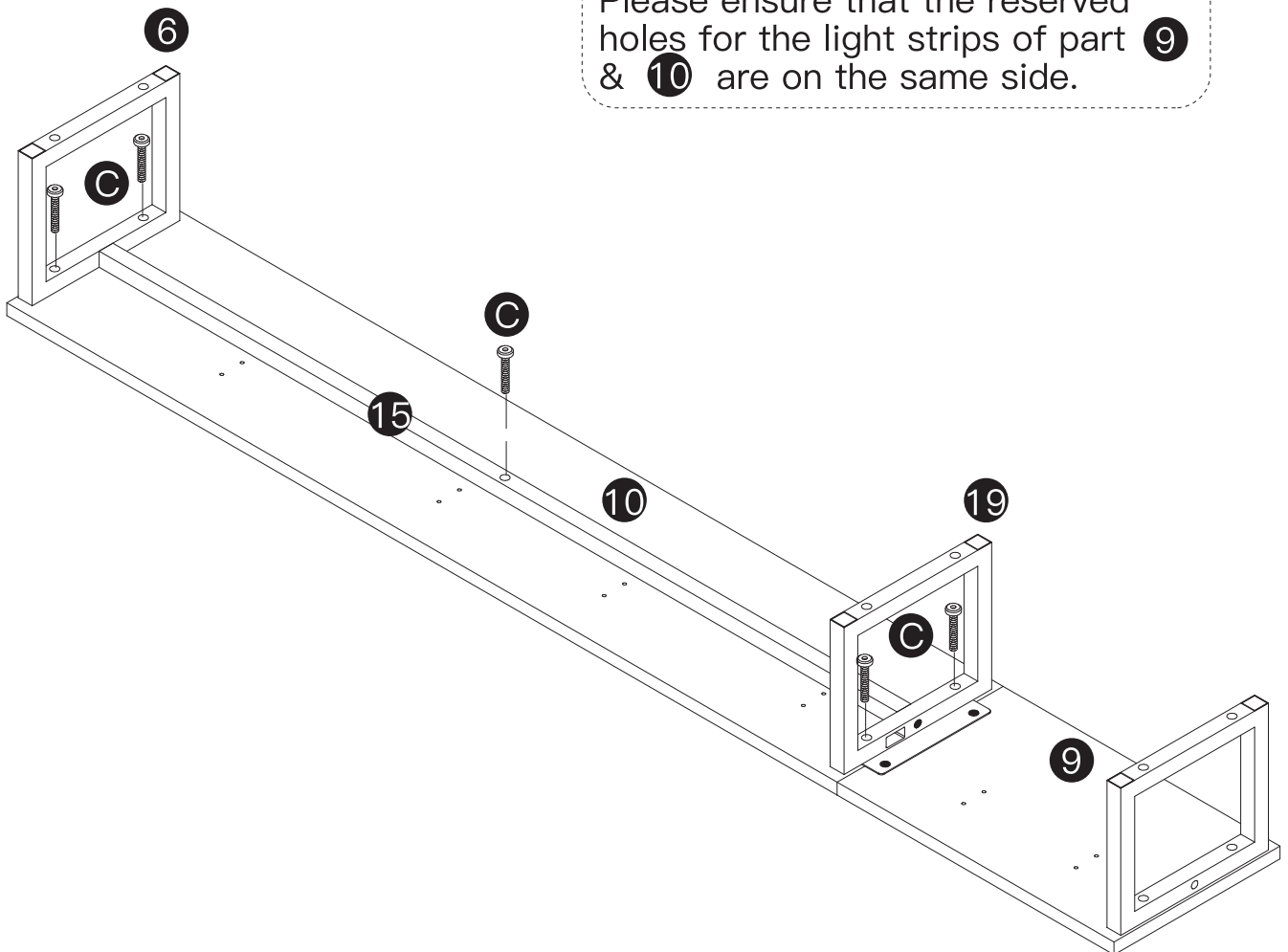

STEP 17

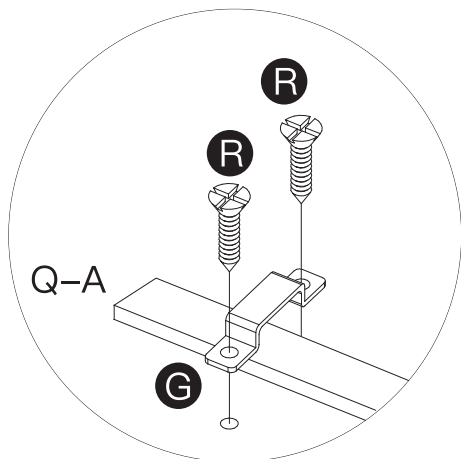
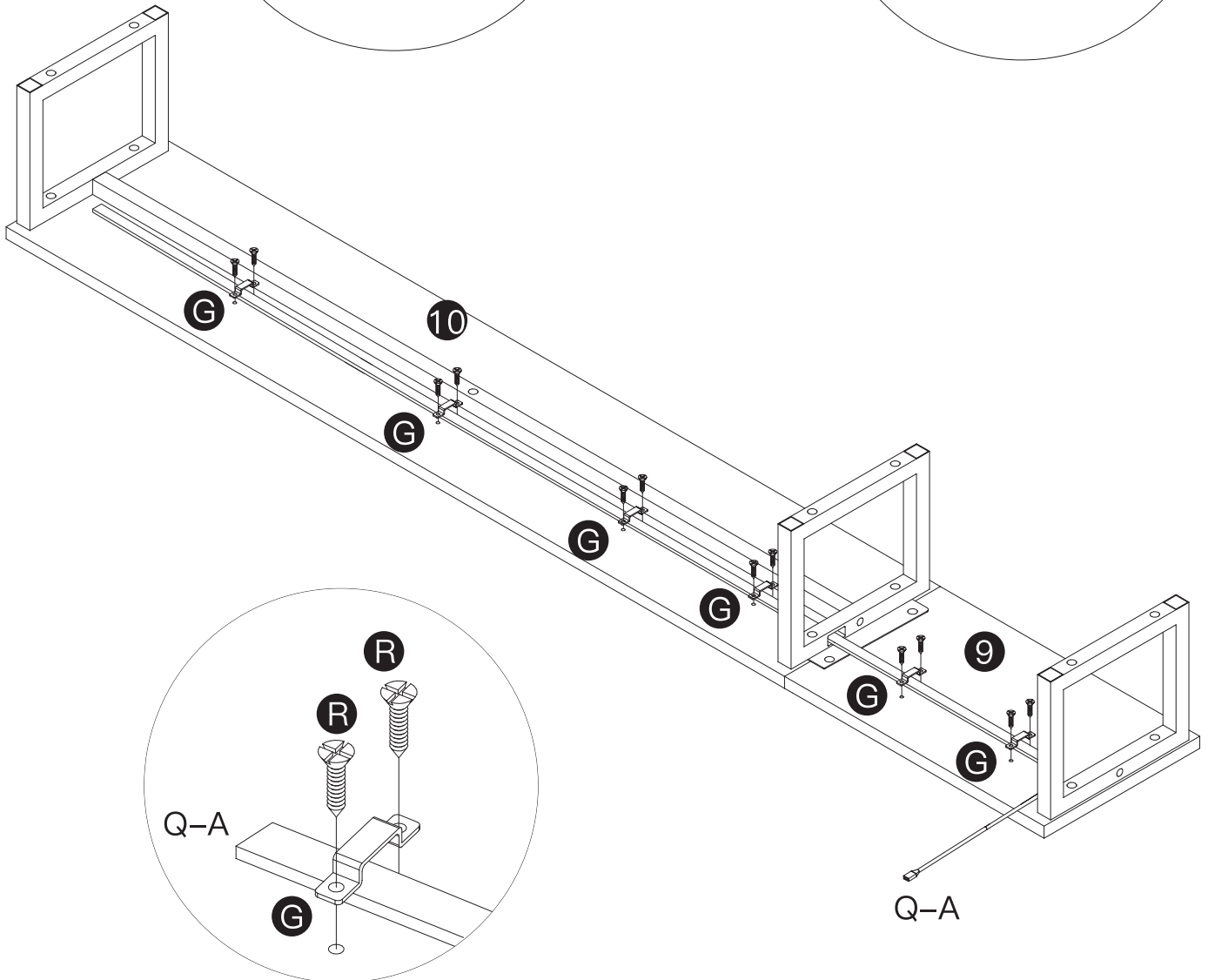
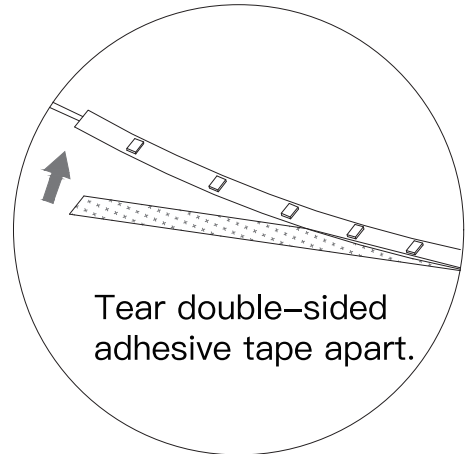
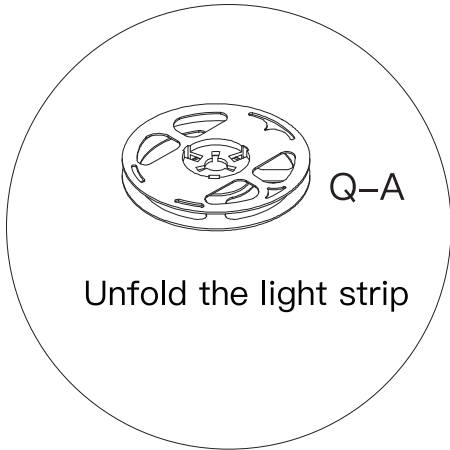
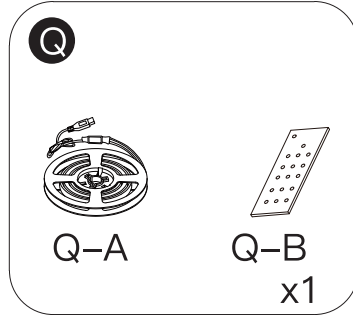
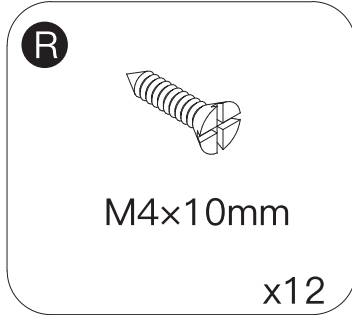
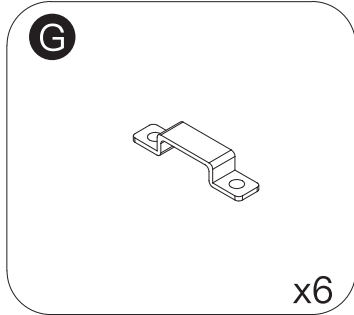

STEP 18

C



M6x25mm

x6

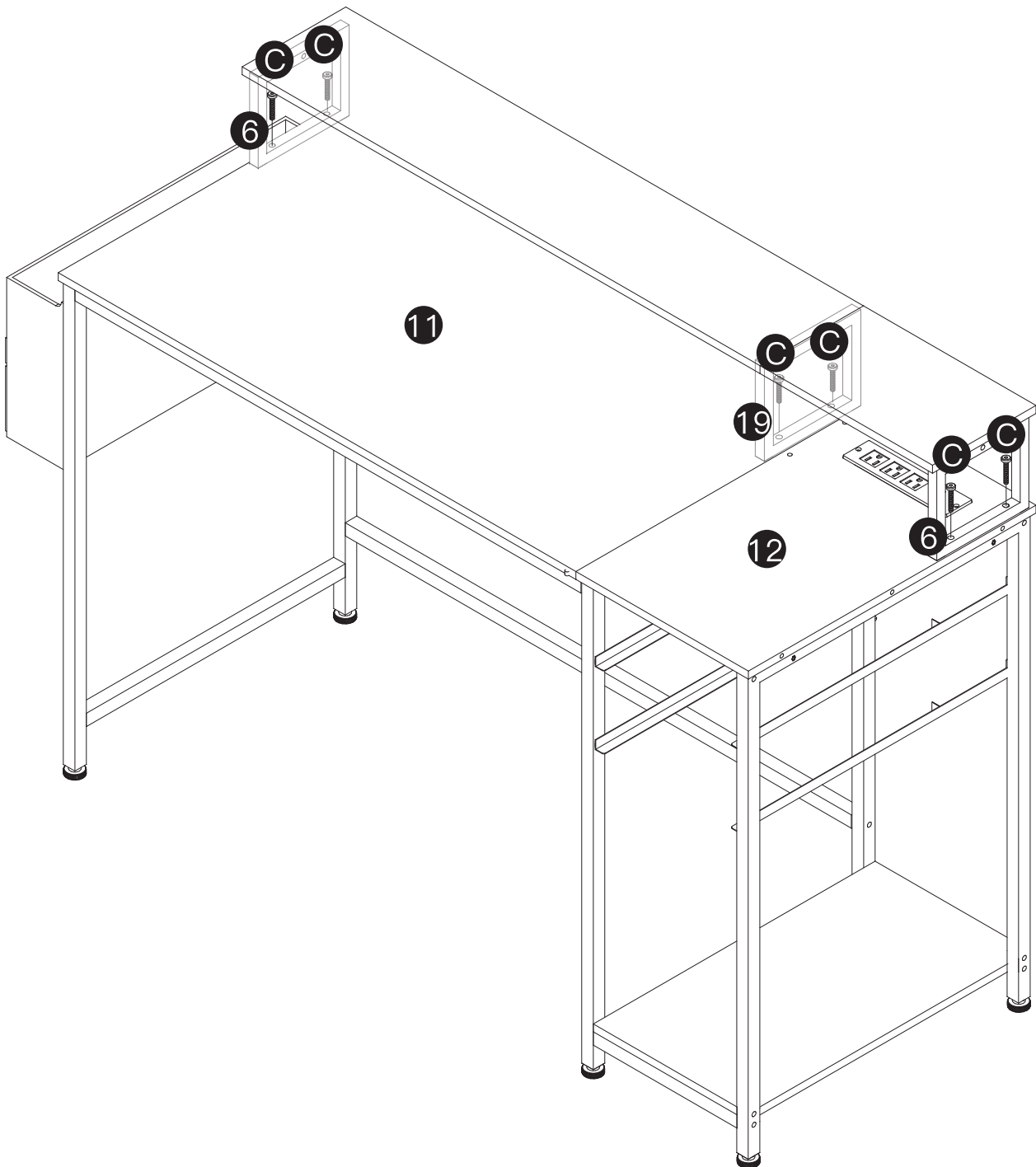

STEP 19

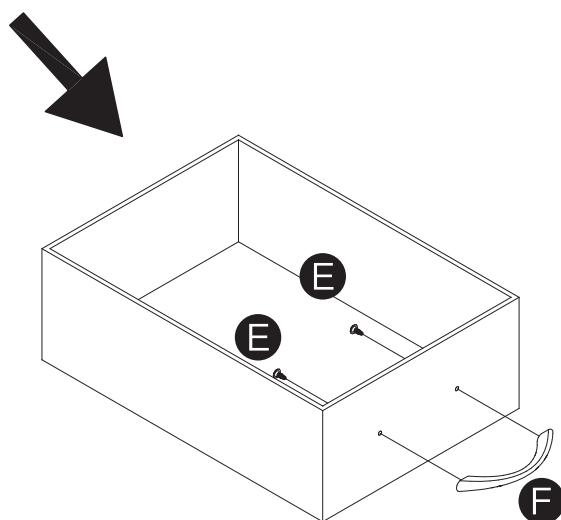
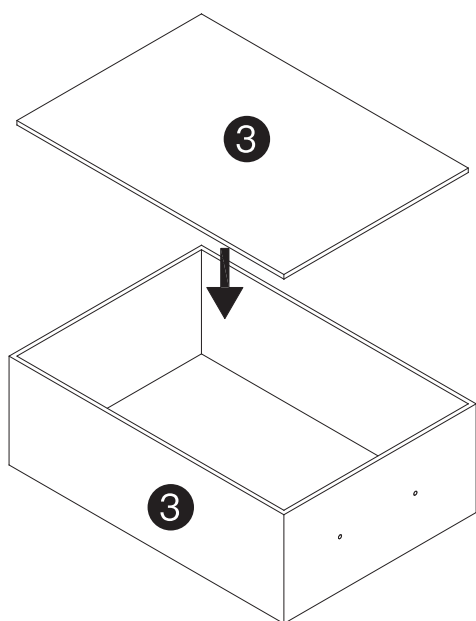
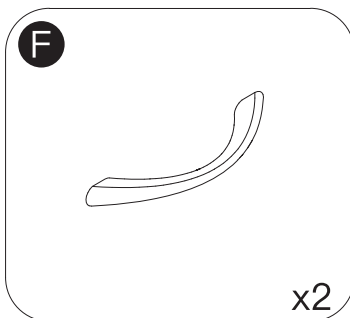
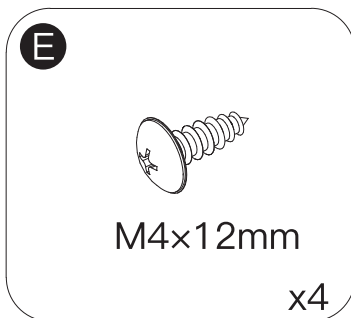
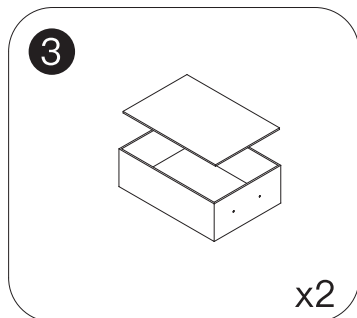

x2

STEP 20

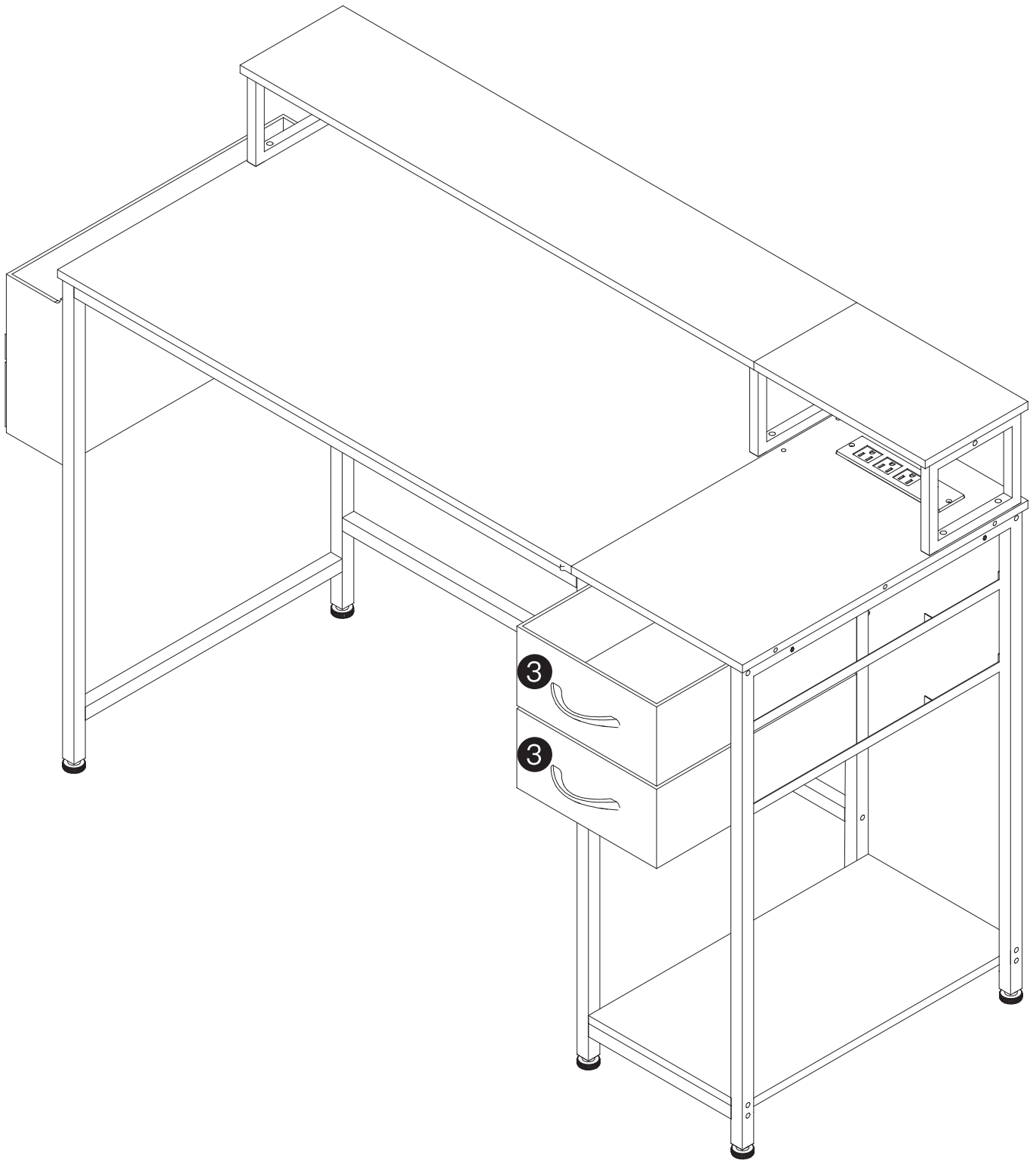

STEP 21

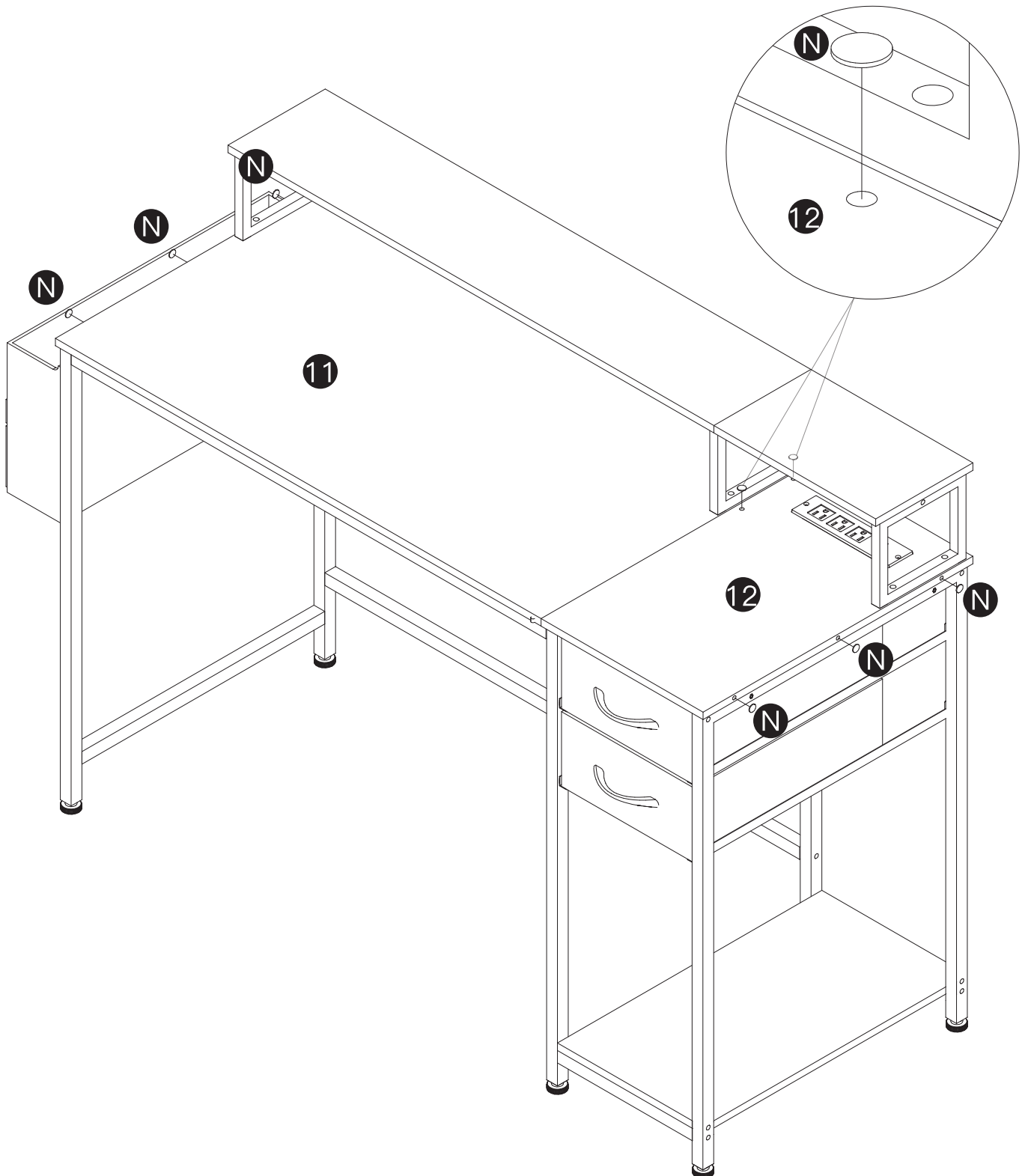
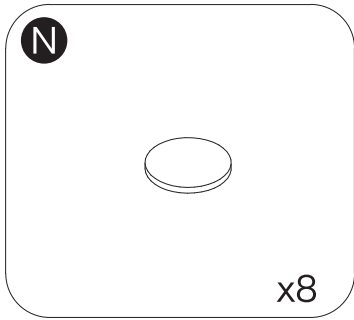

STEP 22

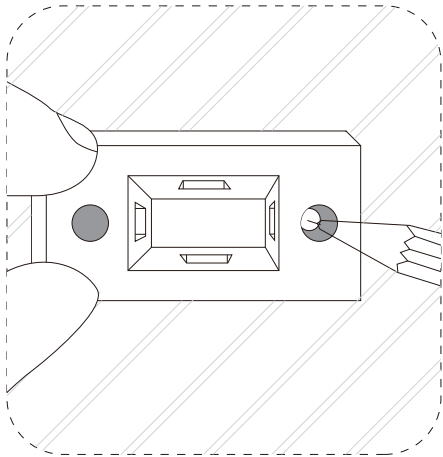
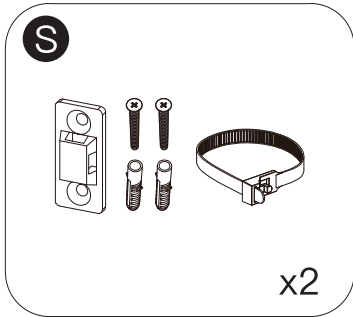

(1) Mark the location of bolt hole.

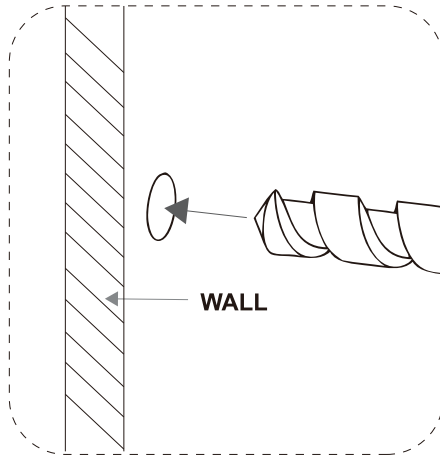

(2) Drill holes at marked location.

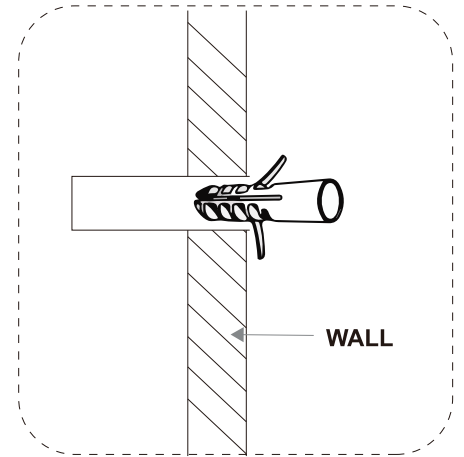

(3) Press the protective bolts in the wall.

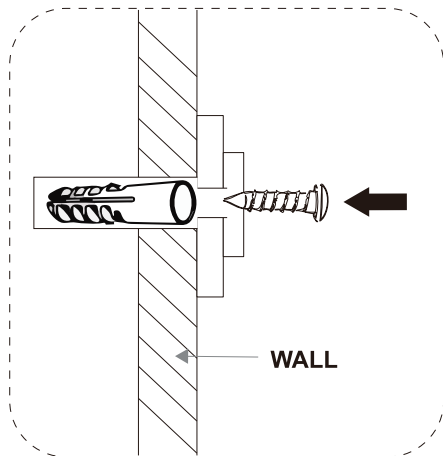

(4) Fix the safety lock on the wall with bolts.

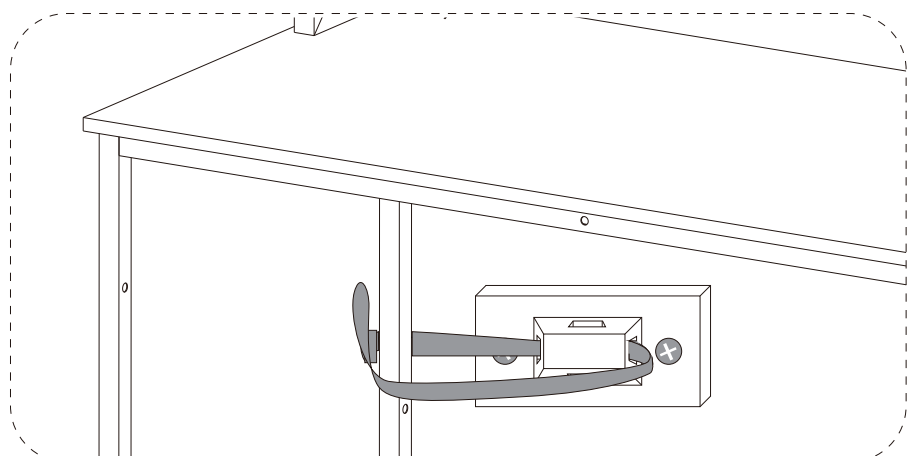

(5) Get the safety belts cross the lock and product, then get fastened.