

# Installation & Assembly

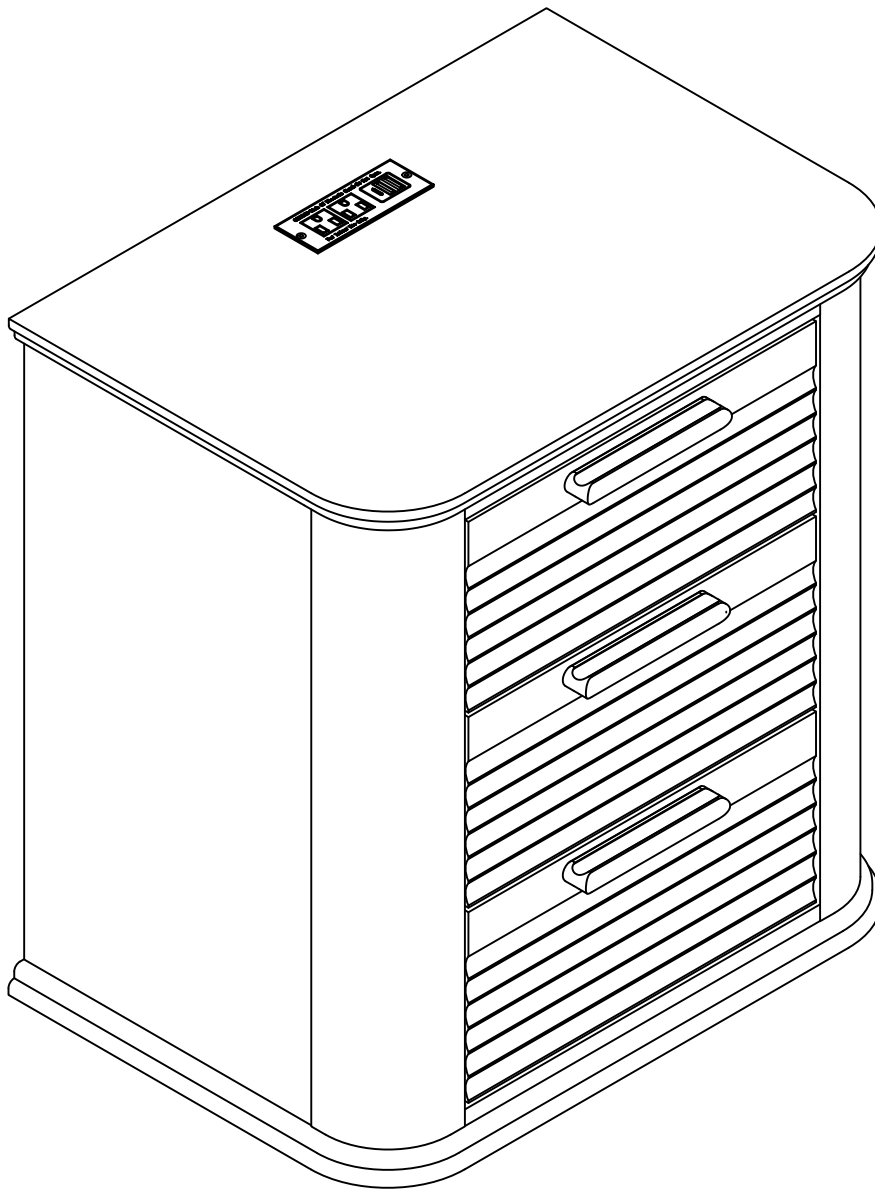

## ATTENTION

If there is any missing, please kindly send us messages to let us know the name of missing part regarding to the first page of instructions.

We will send replacement to you asap. We are concerned about each customer's experience, if there is any loss or damage, please contact us at any time, we will provide effective solutions.



# General Assembly Guidelines

- I. Ensure that all parts and hardware are available before beginning assembly.
- II. Follow each step carefully to ensure the proper assembly of this product.
- III. Two people are recommended for ease in the assembly of this product.
- IV. The three main types of hardware used to assemble this product are : wood dowels , screws and bolts.
- V. The provided glue is to secure wood dowels in place . When first inserting dowels , locate the appropriate hole for the dowel , place a small amount of glue in the hole and insert the dowel . Wipe away excess glue immediately.

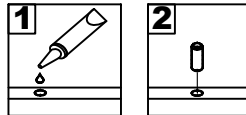

In future assembly steps when dowels are necessary to attach assembly parts together , place a small amount of glue on the end of the dowel before attaching parts together . Wipe away excess glue immediately.

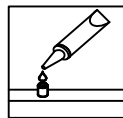

- VI. A Phillips head screwdriver is required for the assembly of this product .

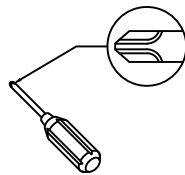



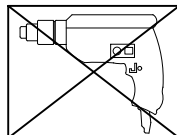



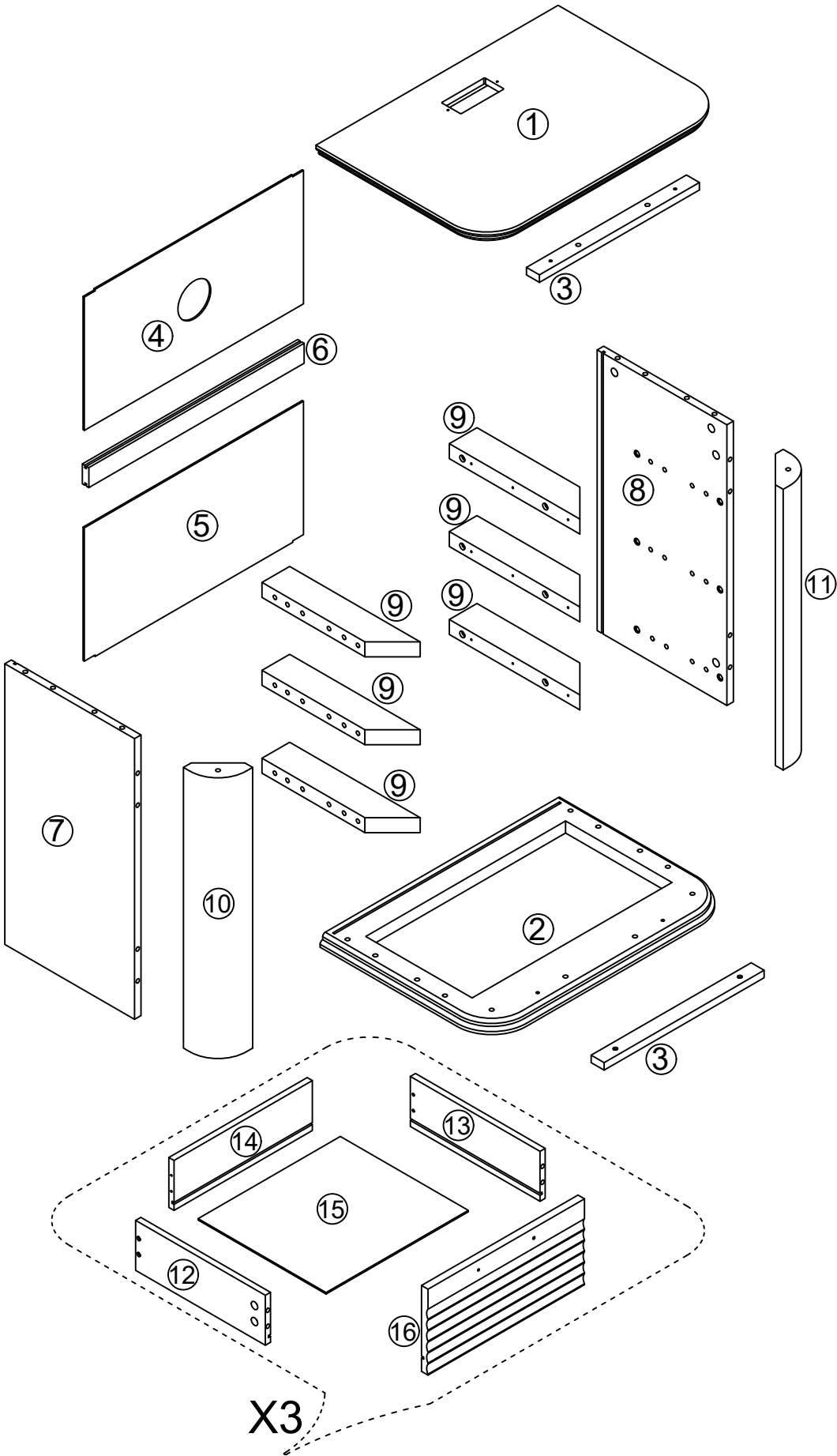



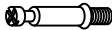











- VI. Power tools should not be used to assemble this product .

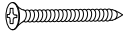

# Parts List



# Hardware List

A		Ø6x32mm	Cam bolt	22	pcs
B		Ø15x11mm	Cam lock	10	pcs
C		Ø6x50mm	Bolt	6	pcs
D			Hex Key	1	pc
E			Plastic wedge	8	pcs
F		Ø3x17mm	Screw	8	pcs
G		Ø4*25mm	Screw	4	pcs
H		M6x65mm	Bolt	12	pcs
I		Ø4x22mm	Bolt	6	pcs
J		130mm	Wooden handle	3	pcs
K			Electric socket	1	pc
L		Ø15x9mm	Cam lock	12	pcs
M		Ø30mm	Sticker	22	pcs
N		Ø8x30mm	Wooden dowel	40	pcs
O		Ø3*12	Screw	38	pcs
P		12"	Drawer slides	3	sets
Q		Ø30x3mm	Base pad	4	pcs
R		Ø4x32mm	Screw	12	pcs
S		Ø4x40mm	Screw	1	pcs
T		Ø4x14mm	Screw	1	pcs
U			Anti-inversion piece	1	pcs
V		Ø6x40mm	House lizard	1	pcs
W			Glue tube	1	pcs

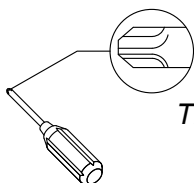

Philips head screwdriver required for assembly  
(not included)

*The hardware quantities listed above are required for proper assembly.  
Some extra hardware may also have been included.*

# CAM LOCK/BOLT FASTENING INTRODUCTION

(You will use it during assembly)

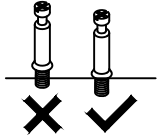
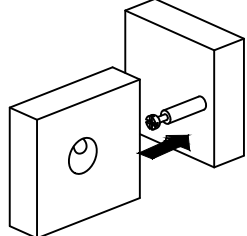
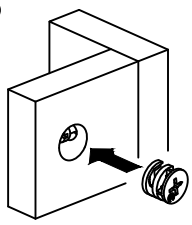
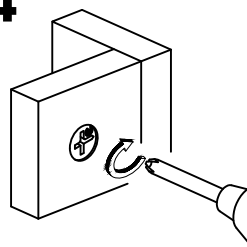
<p><b>1</b></p> 	<p><b>2</b></p> 	<p><b>3</b></p> 	<p><b>4</b></p> 
<p>1.Screw cam bolt into the threaded anchor gently. (Attention:don't screw cam bolt too deep or too shallow.)</p>	<p>2.Please connect the 2 boards you want connect by inserting cam bolt.</p>	<p>3.Insert the cam lock into the round hole of the board. (Attention:point the arrow on the top of the cam lock to the outer edge.)</p>	<p>4.Turn the cam lock clockwise until it is firmly tightened.</p>

Please use [B] and [L] CAM LOCKS as shown in the illustrations.

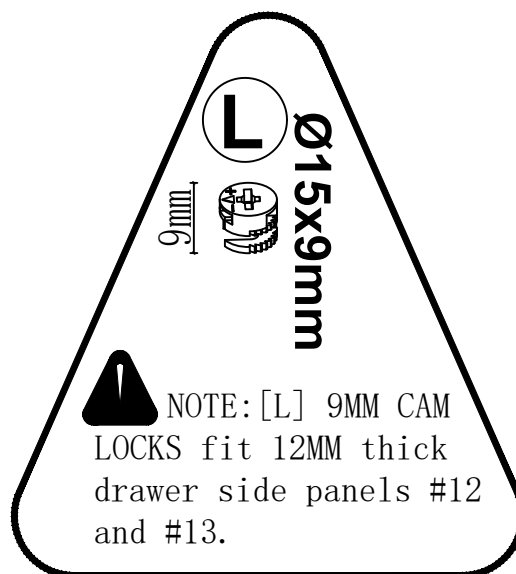
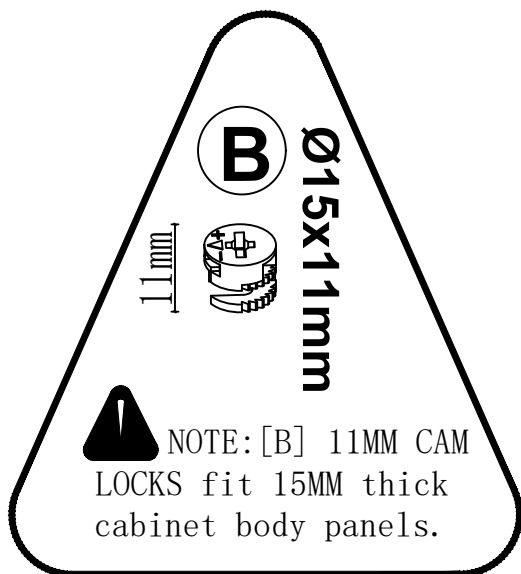

# Step 1

R



X12

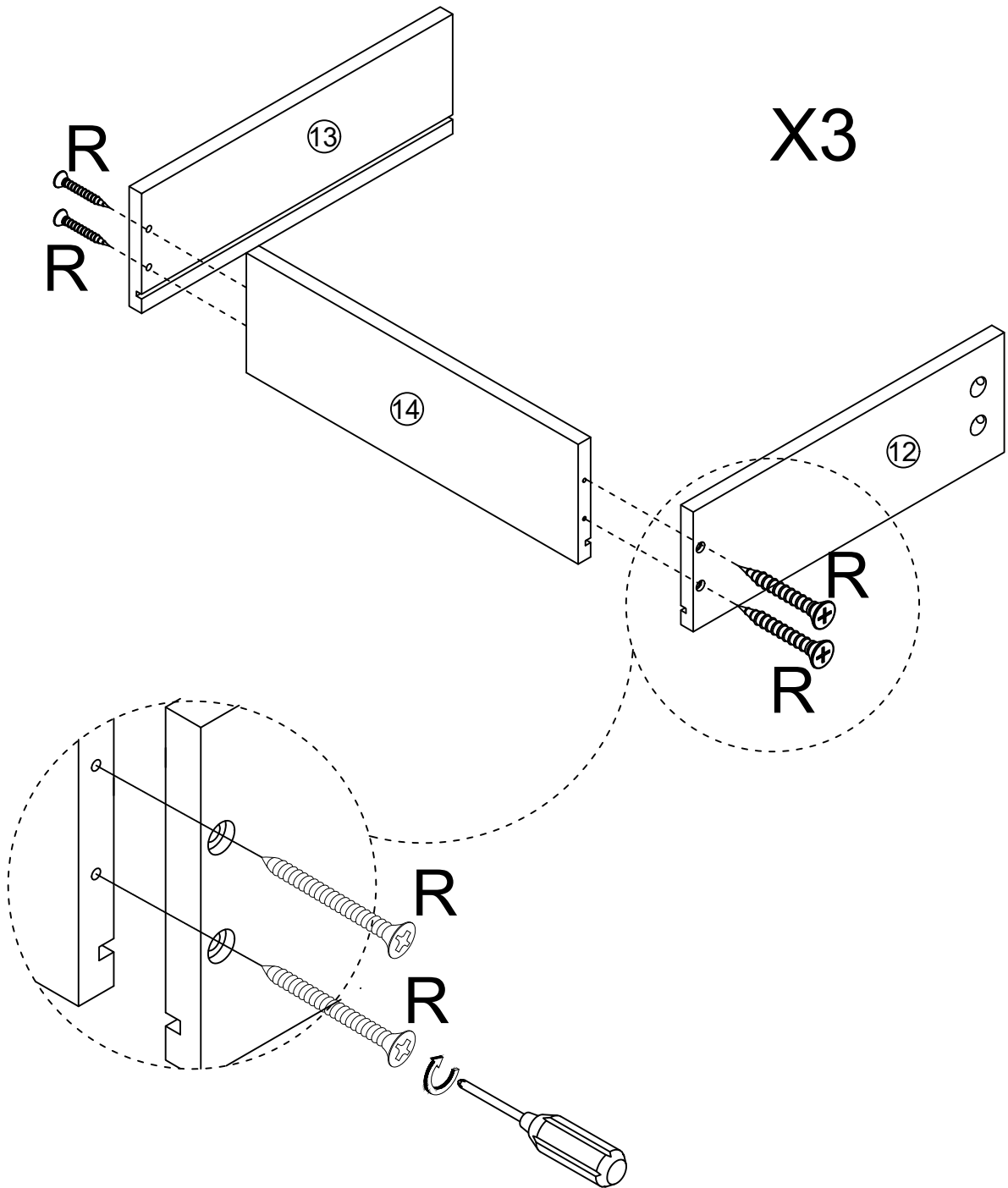

# Step 2

A

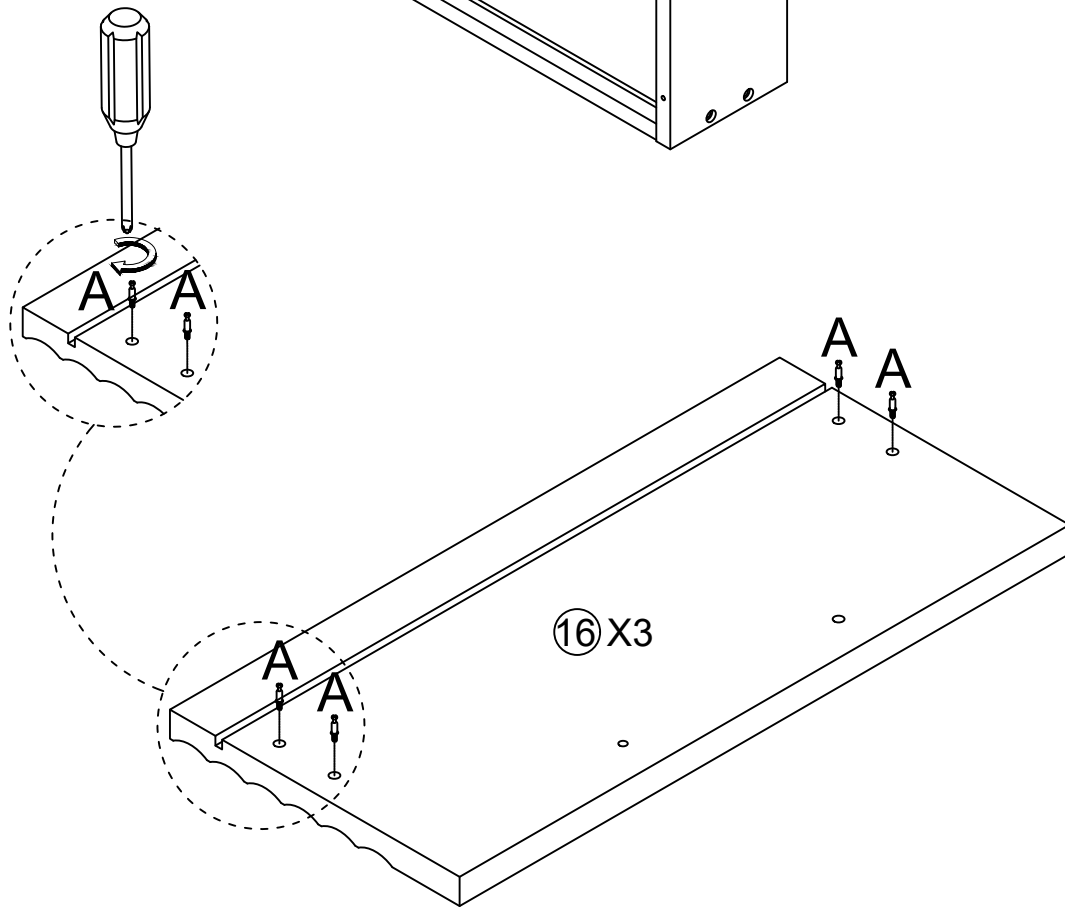
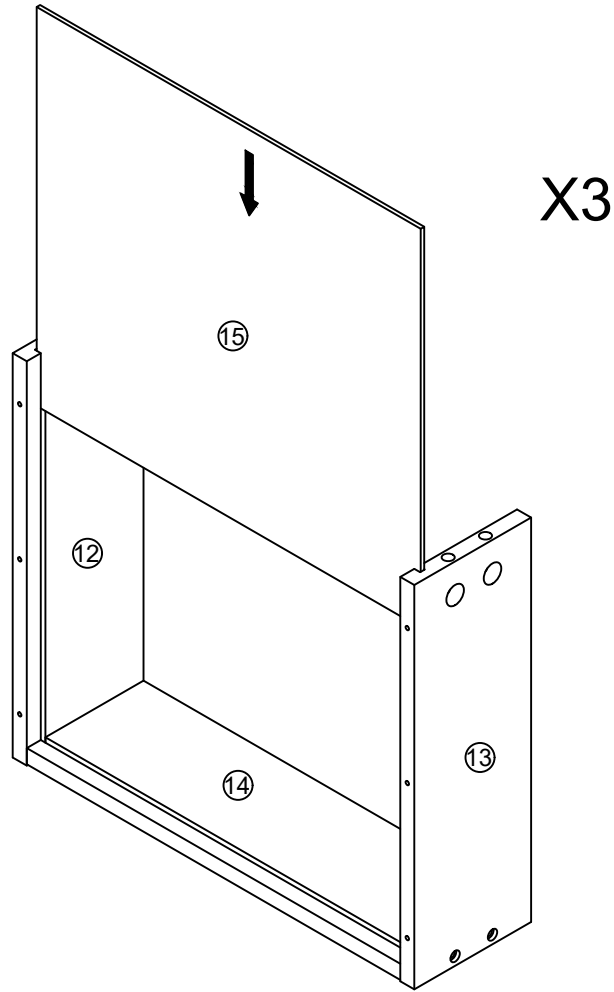
X12



# Step 3

L
9mm 
X12



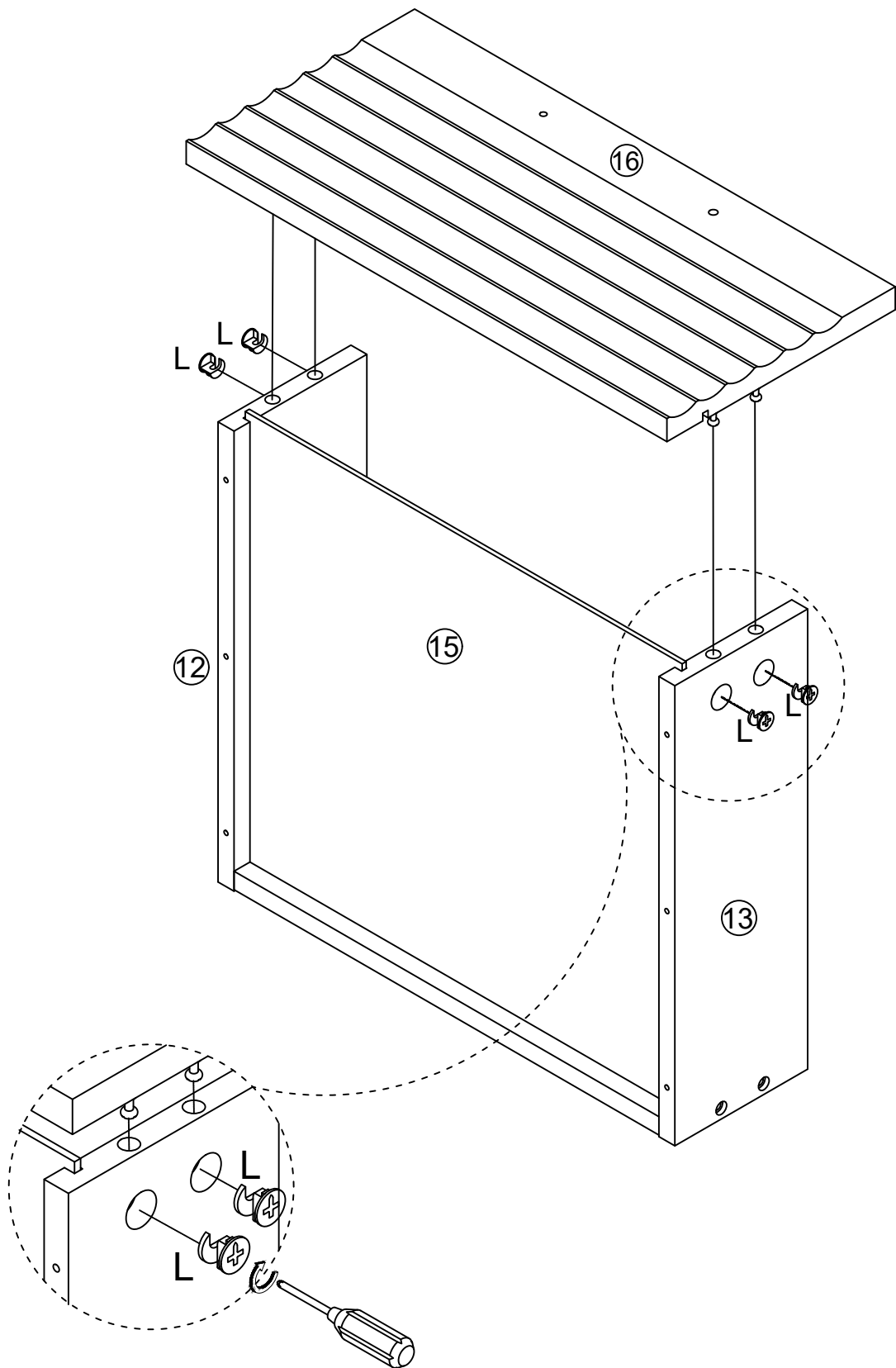

NOTE: Be sure to use [L] 9MM CAM LOCKS for the panels #13 and #12.

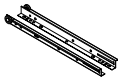

# X3

# Step 4

P	O
	
X3	X18



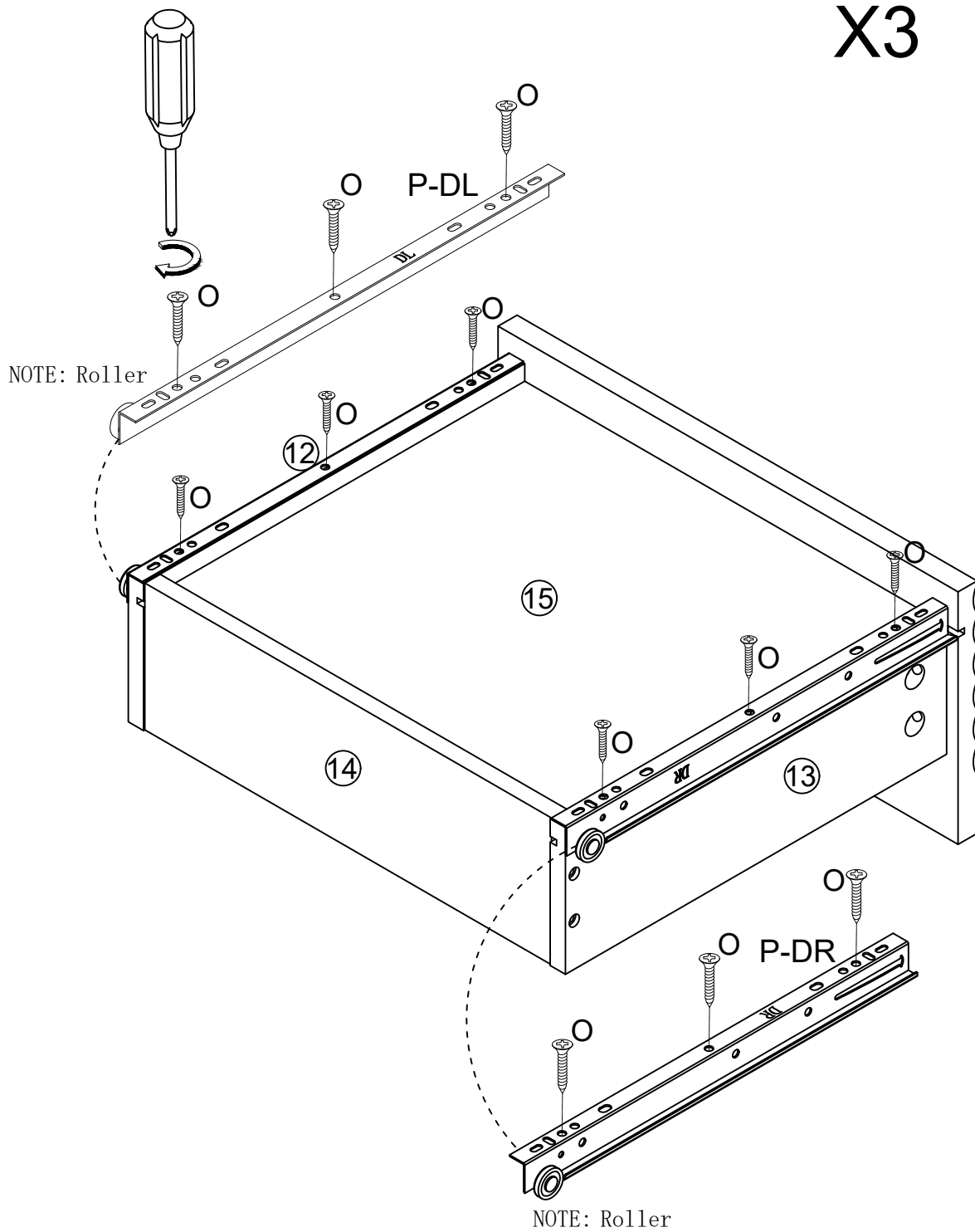

NOTE:

Refer to the images to identify P-DL (left) and P-DR (right). Attach P-DL to #12 panel and P-DR to #13 panel. [O] screws must go in the exact spots shown.



# Step 5

J	I
	
X3	X6

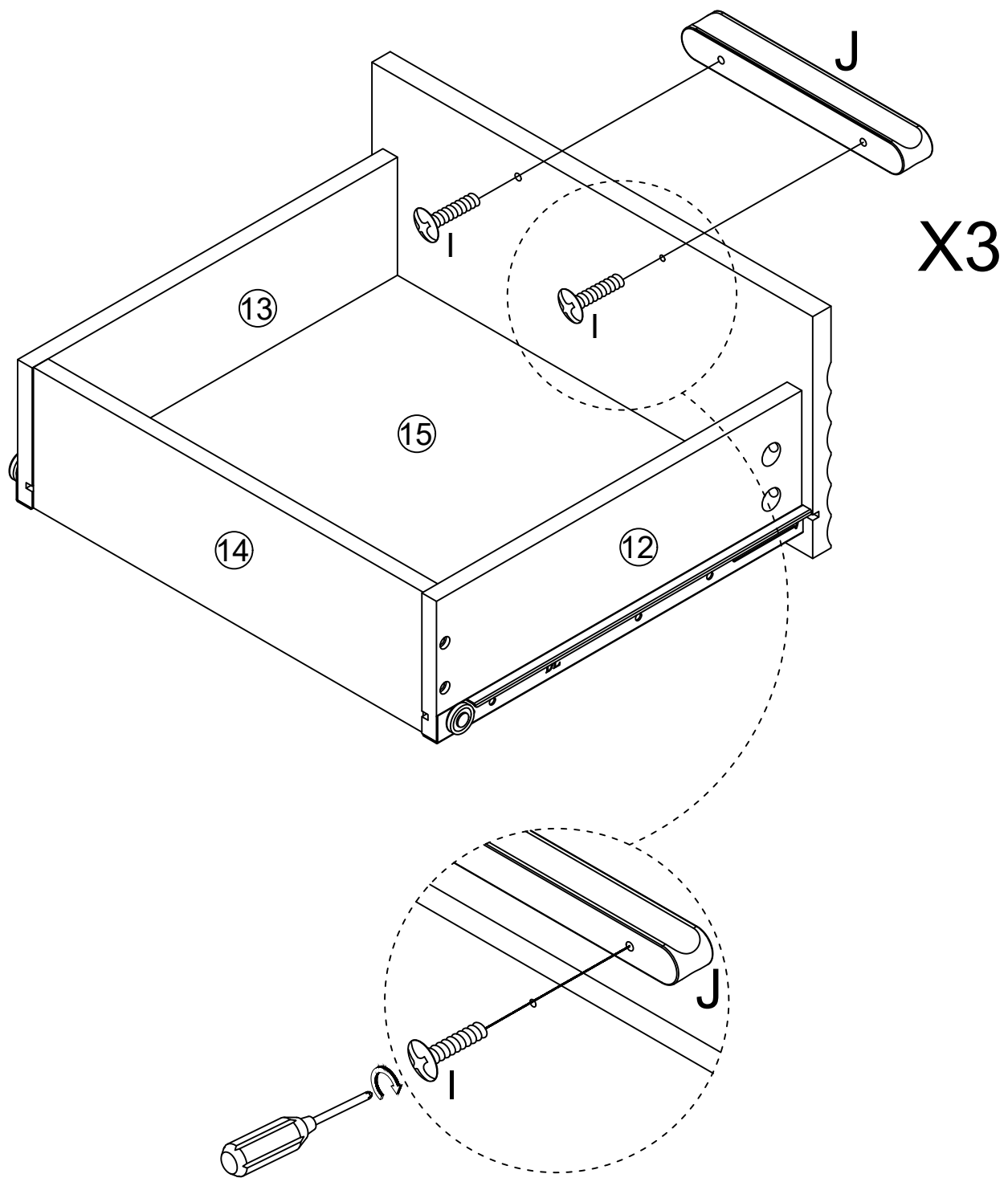

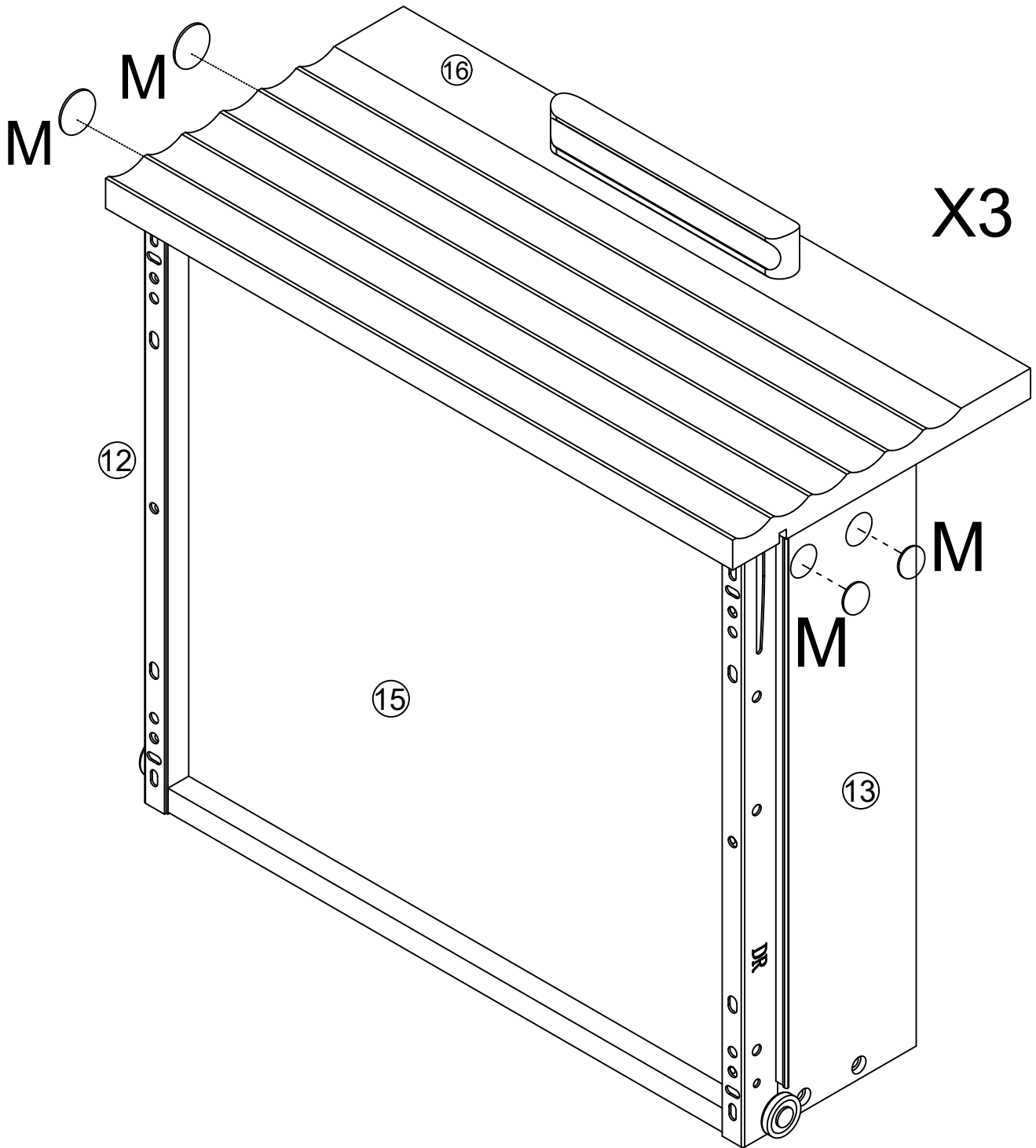

# Step 6

M
O
X12



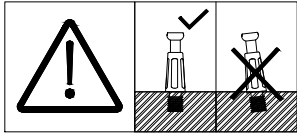

# Step 7

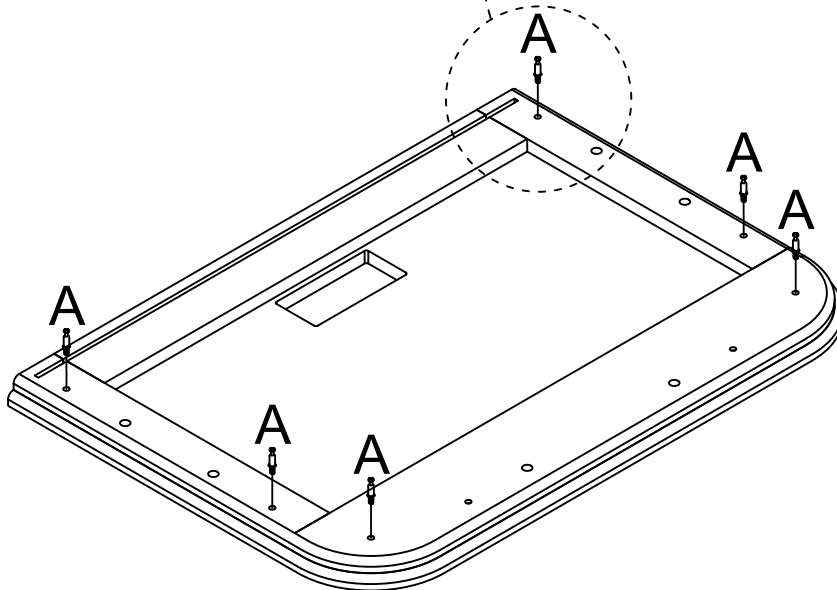
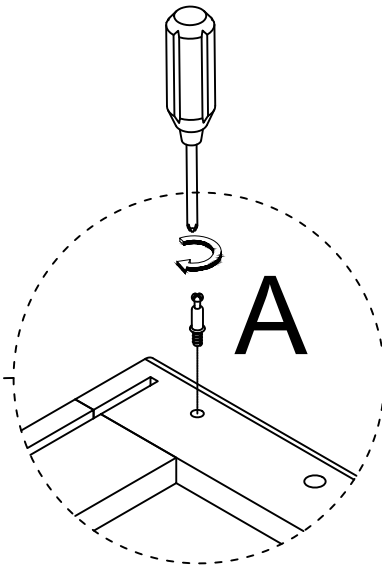
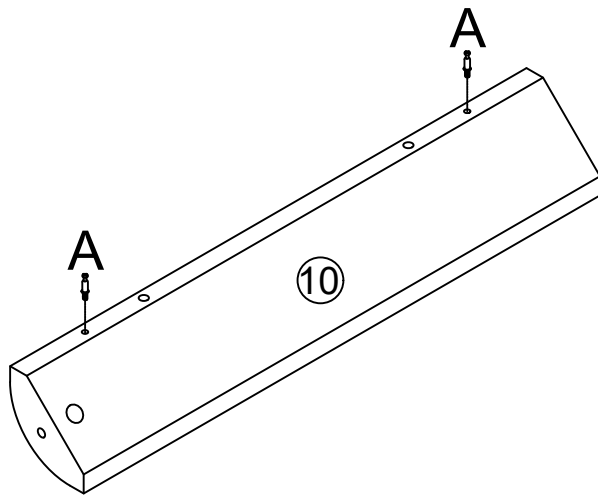
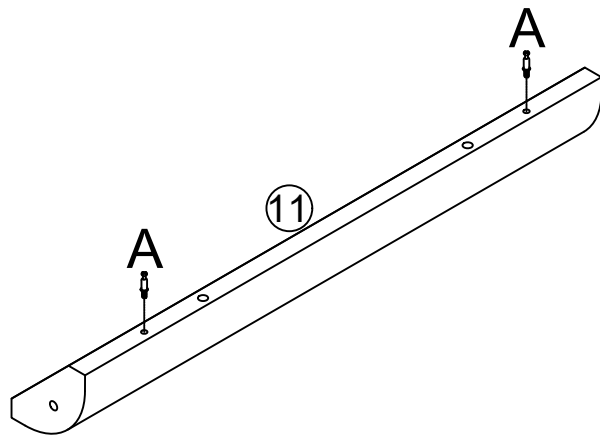

A

X10



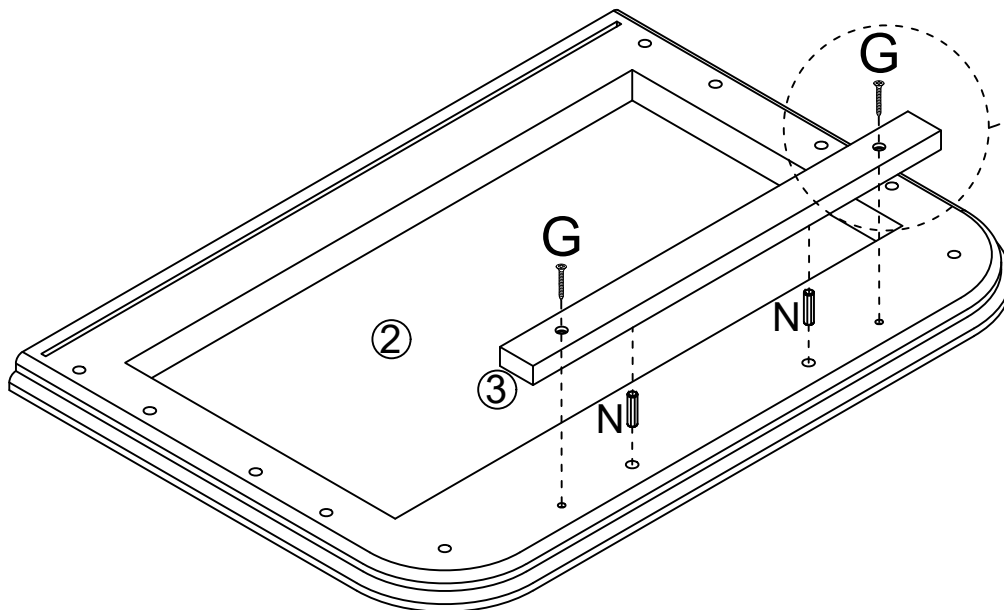
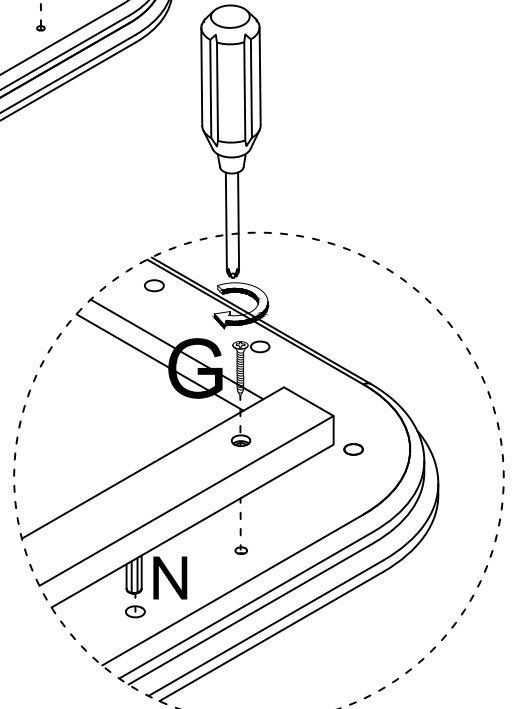
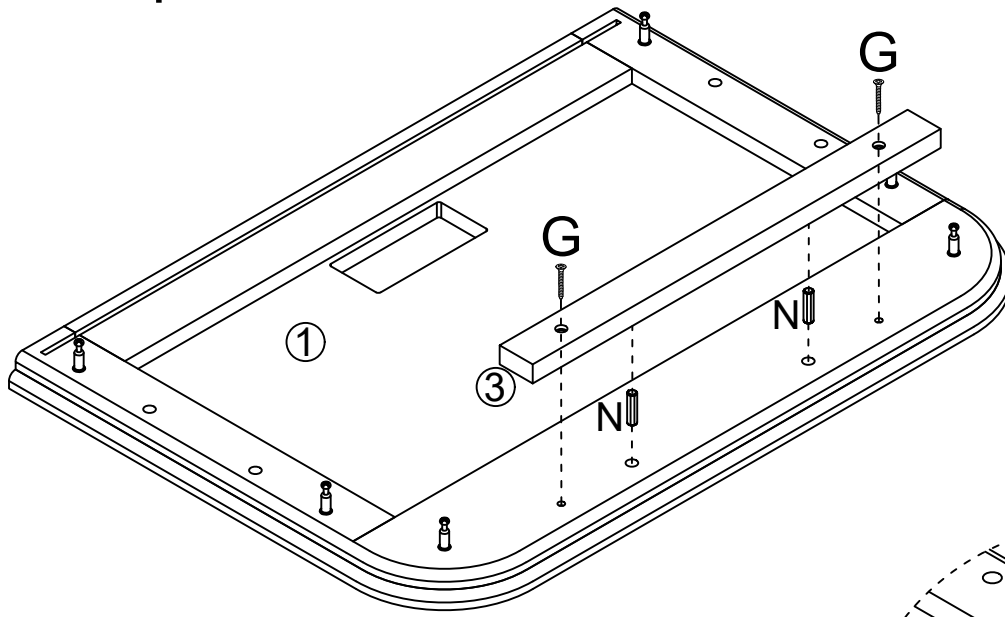

# Step 8

N	G
	
X4	X4



# Step 9

N	B
	
X4	X4

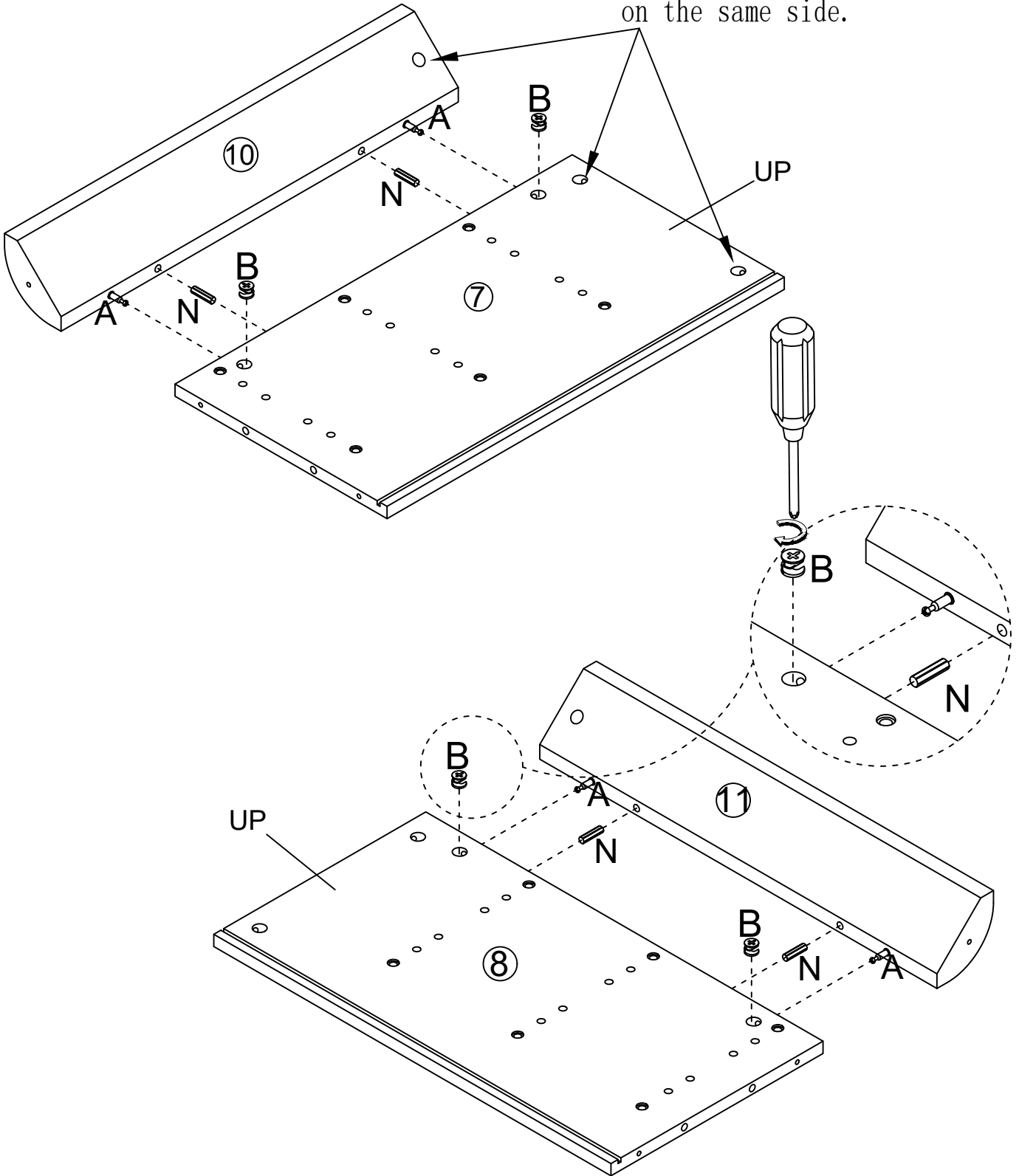

NOTE: Use board of #7 to connect #10 leg,  
use board of #8 to connect #11 leg.

NOTE: Three cam lock holes should be  
on the same side.



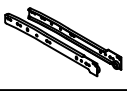

# Step 11

P	O
	
X3	X18



NOTE:

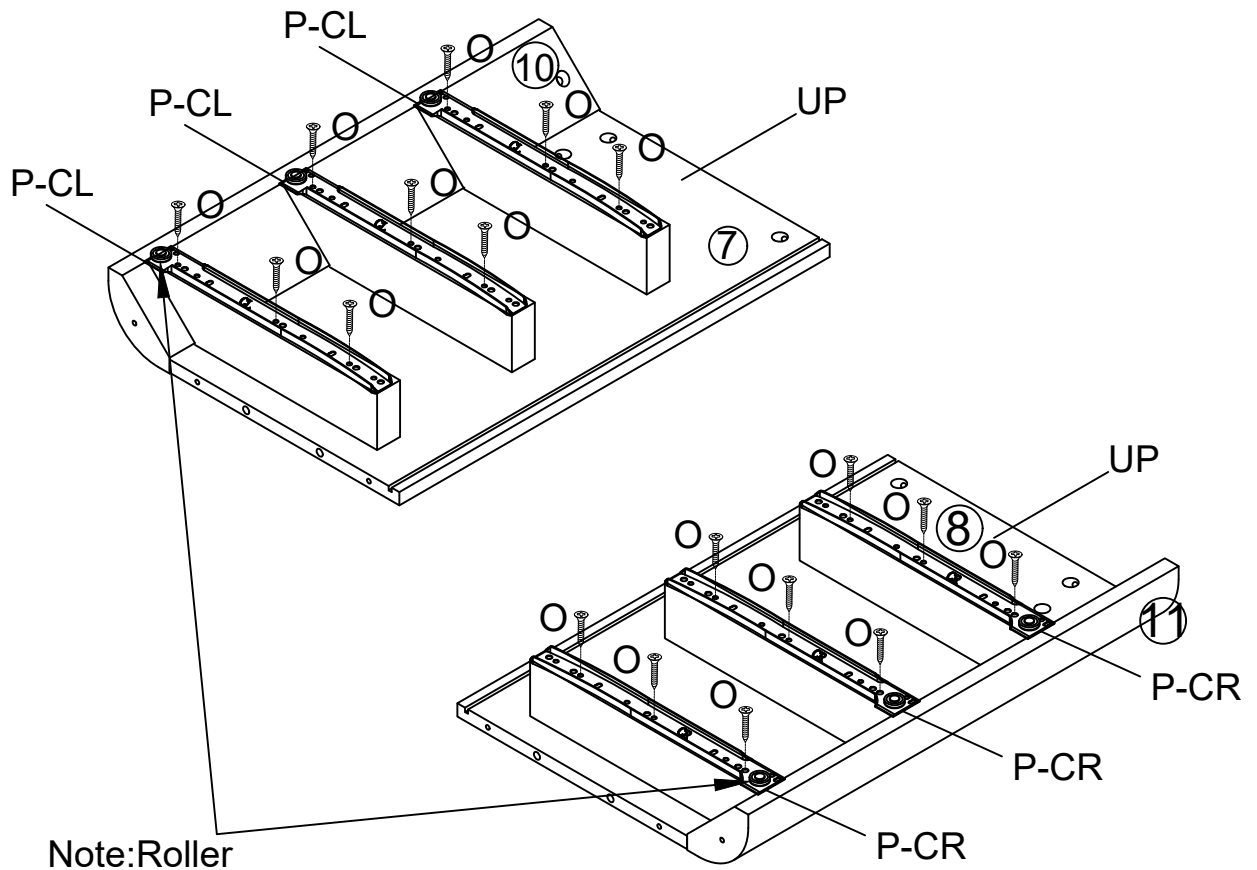
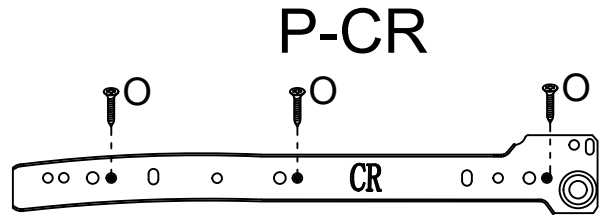
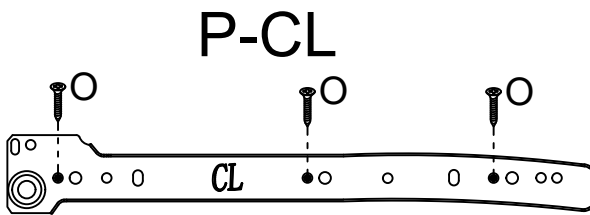

Refer to the images to identify P-CL (left) and P-CR (right). Attach P-CL to #7 panel and P-CR to #8 panel. [O] screws must go in the exact spots shown.



# Step 12

N	C	D
		
X4	X6	X1

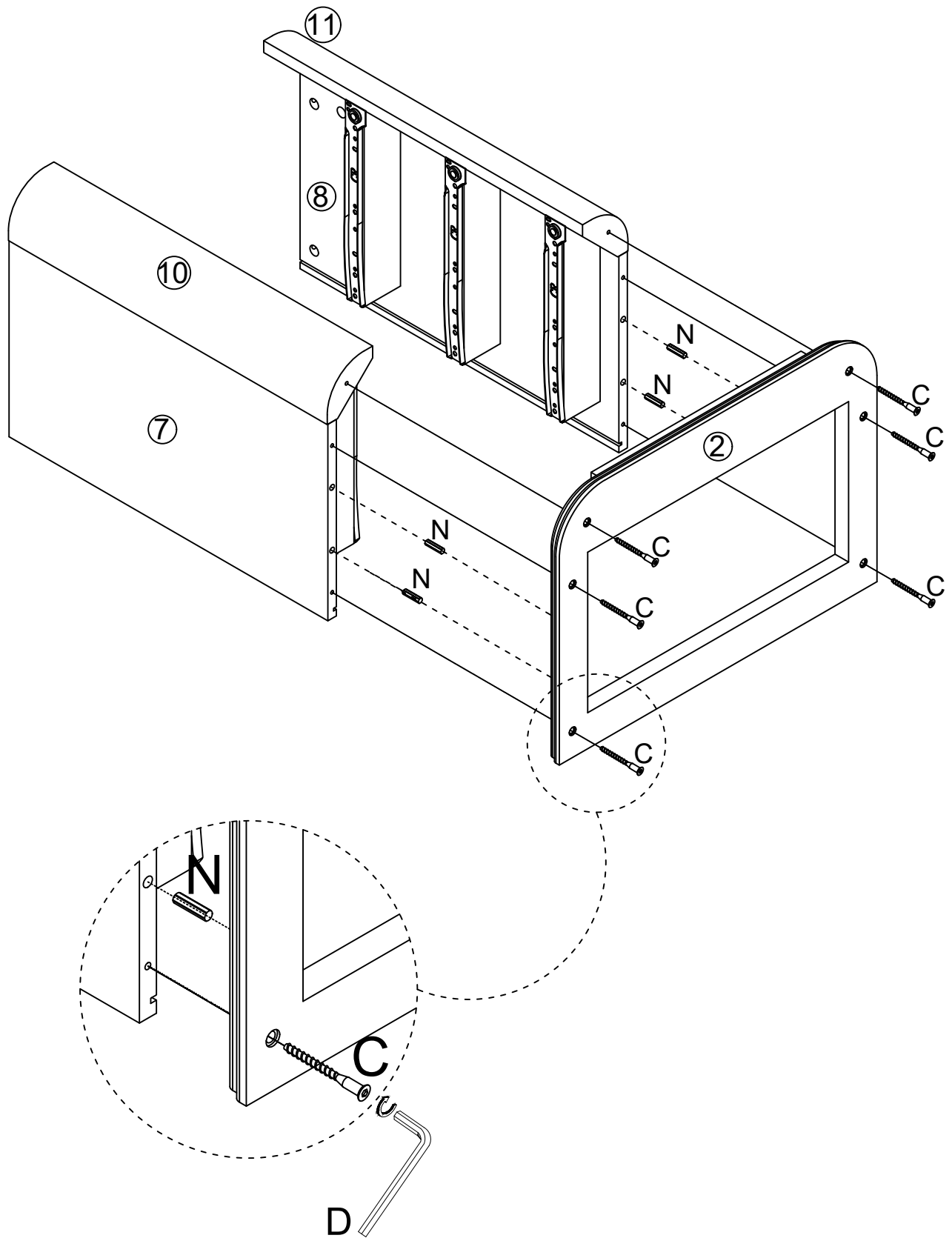

# Step 13

Q

O

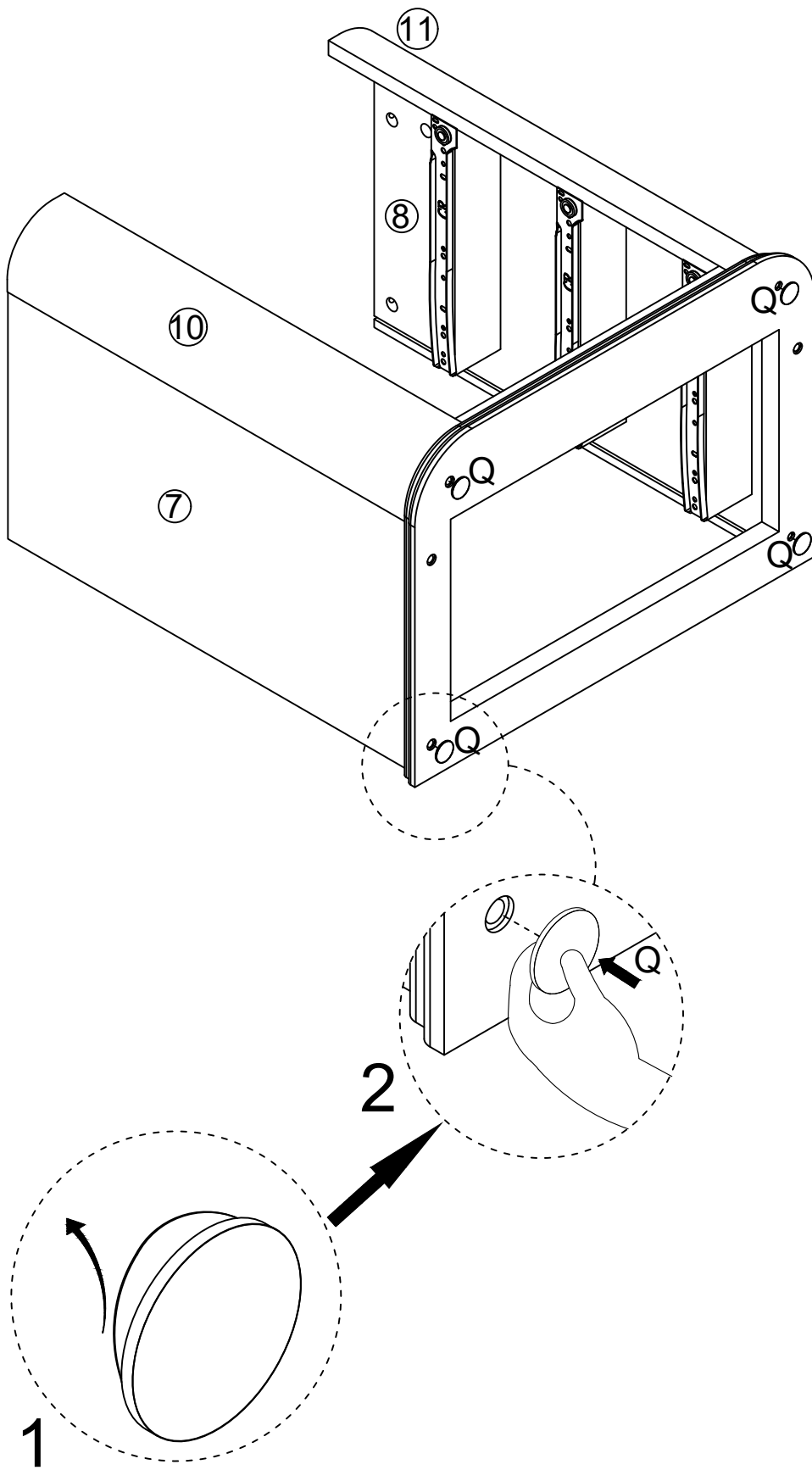

X4

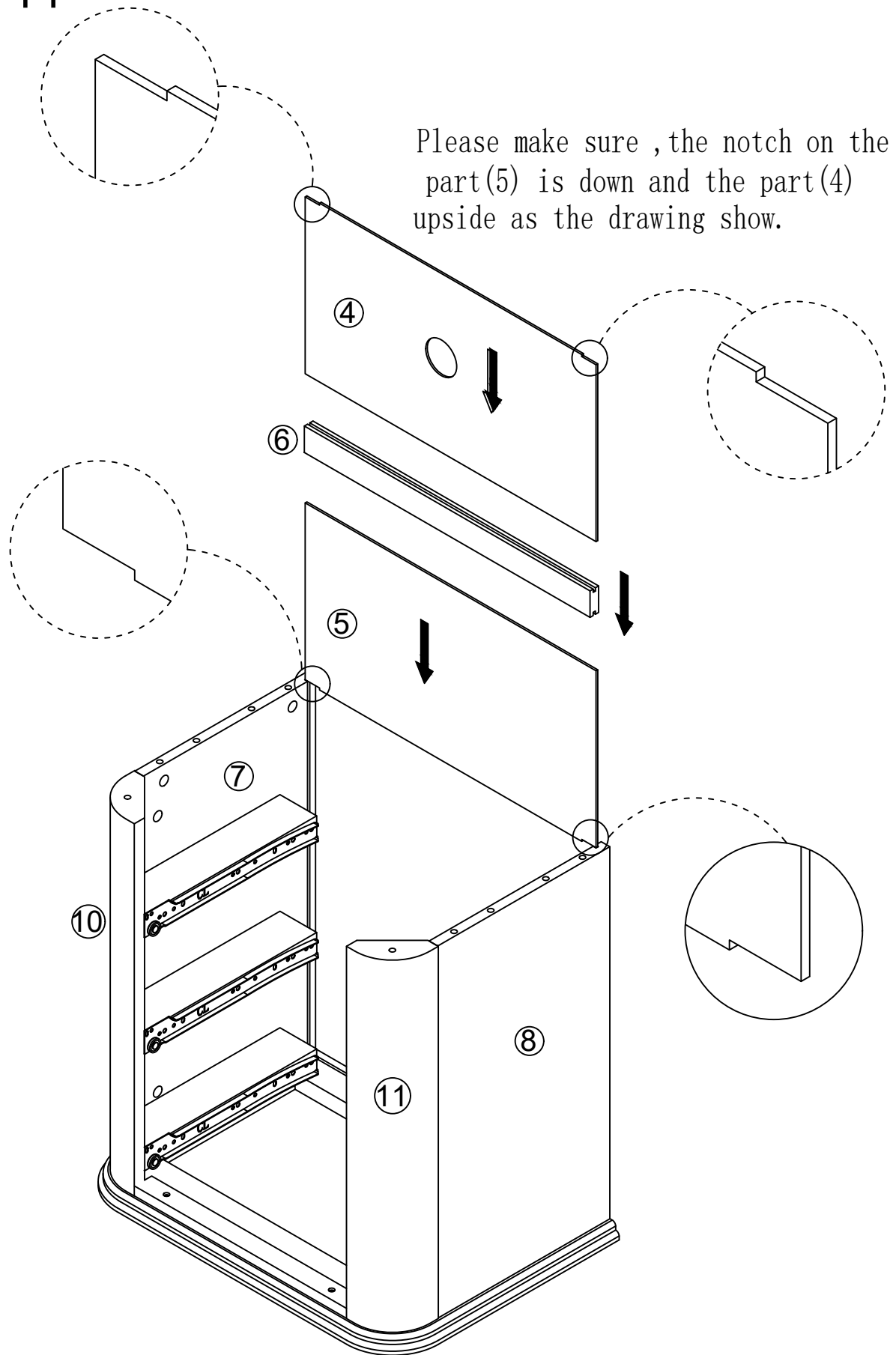

# Step 14



# Step 15

N	B
	
X4	X6

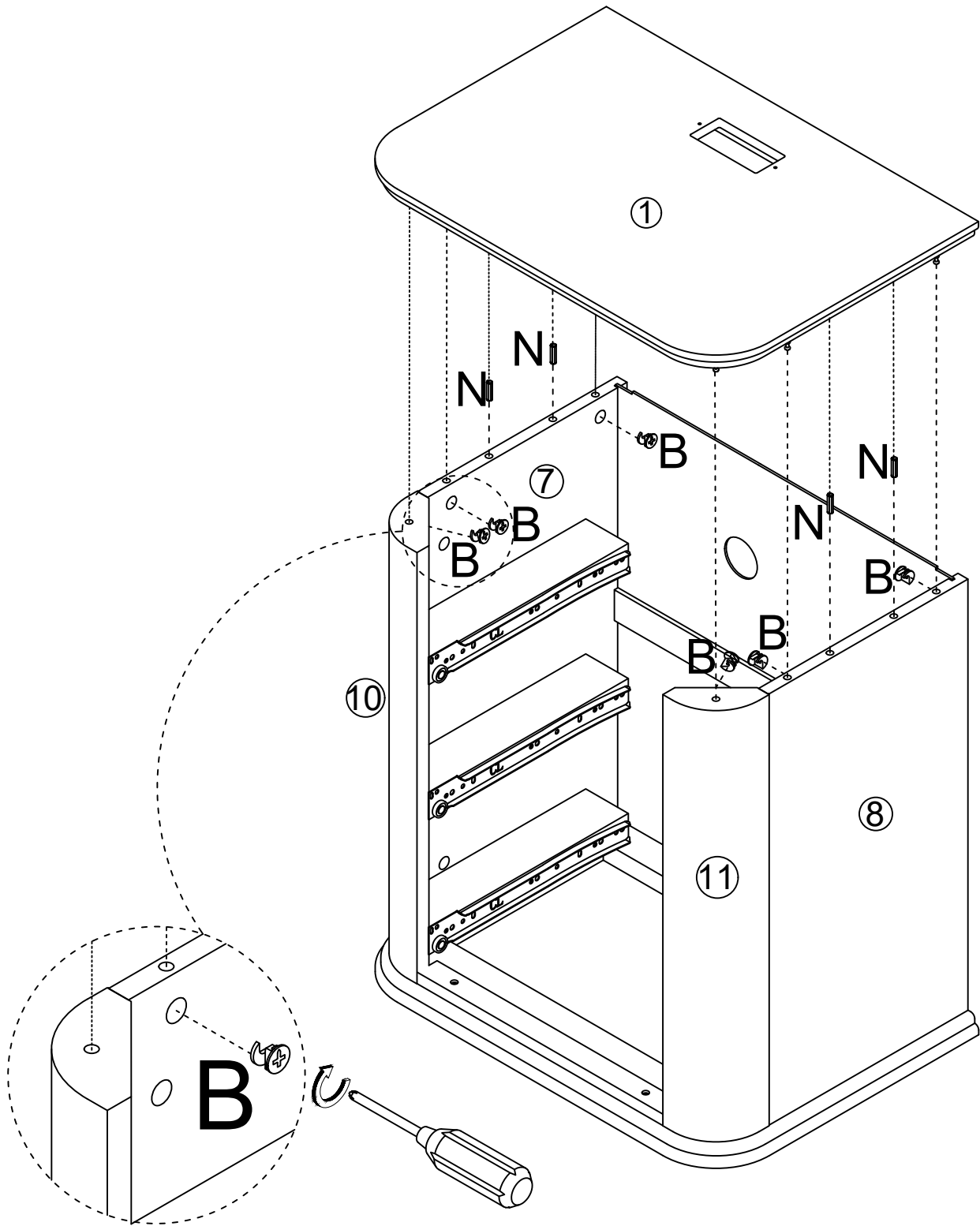

# Step 16

Notice: Covered all the cam lock holes with the sticker(M).



M

O

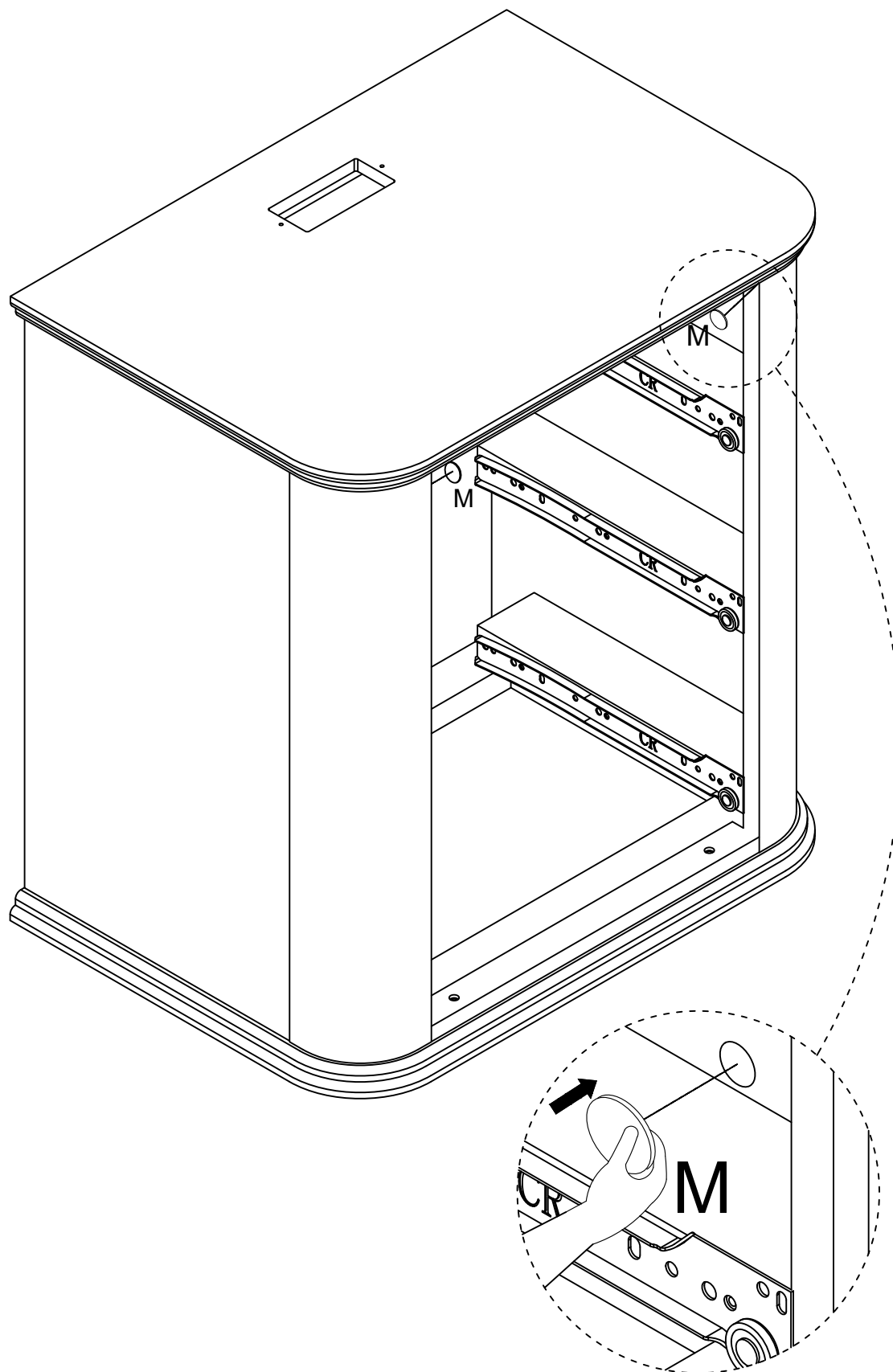
X8

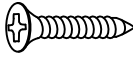

# Step 17

F	E
	
X8	X8

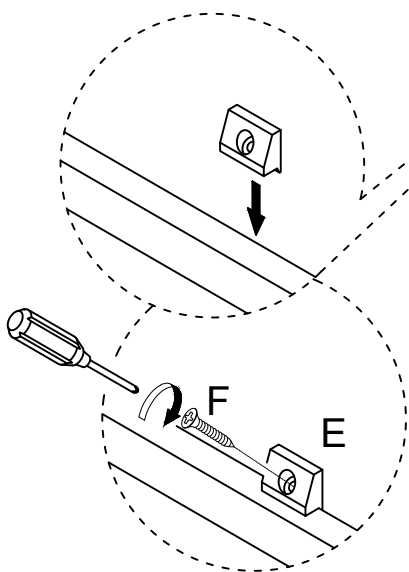
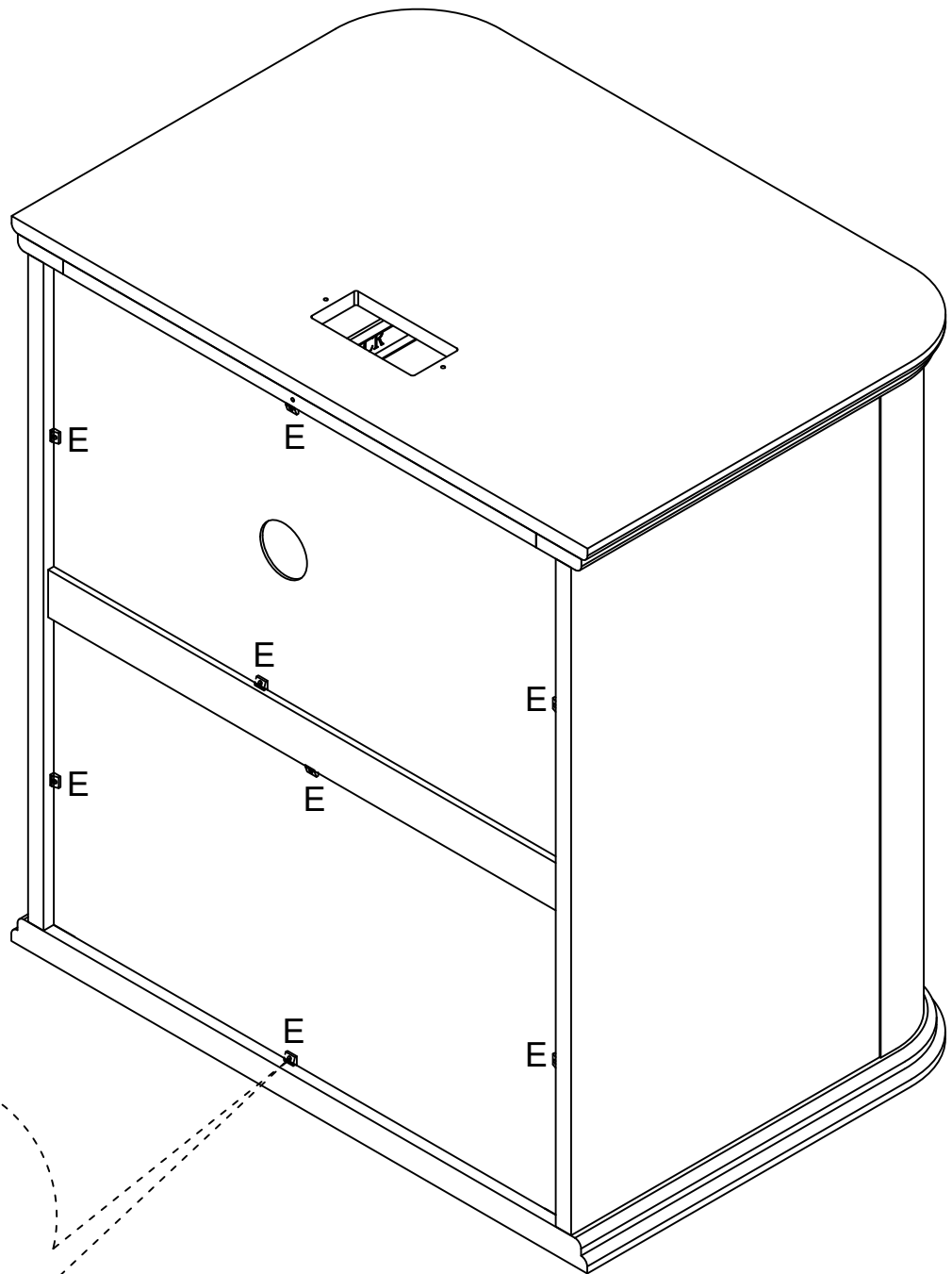

# Step 18

K



X1

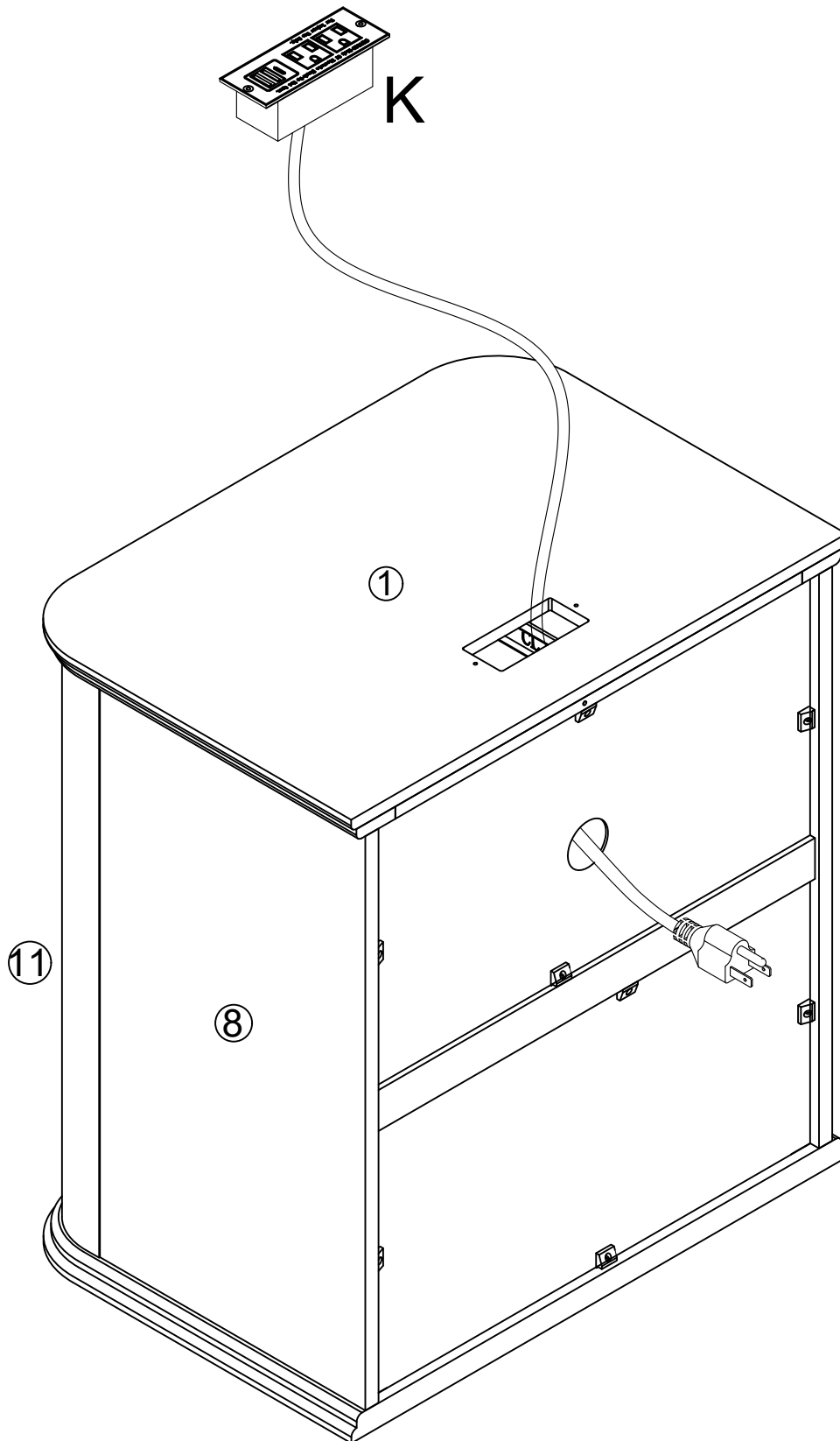

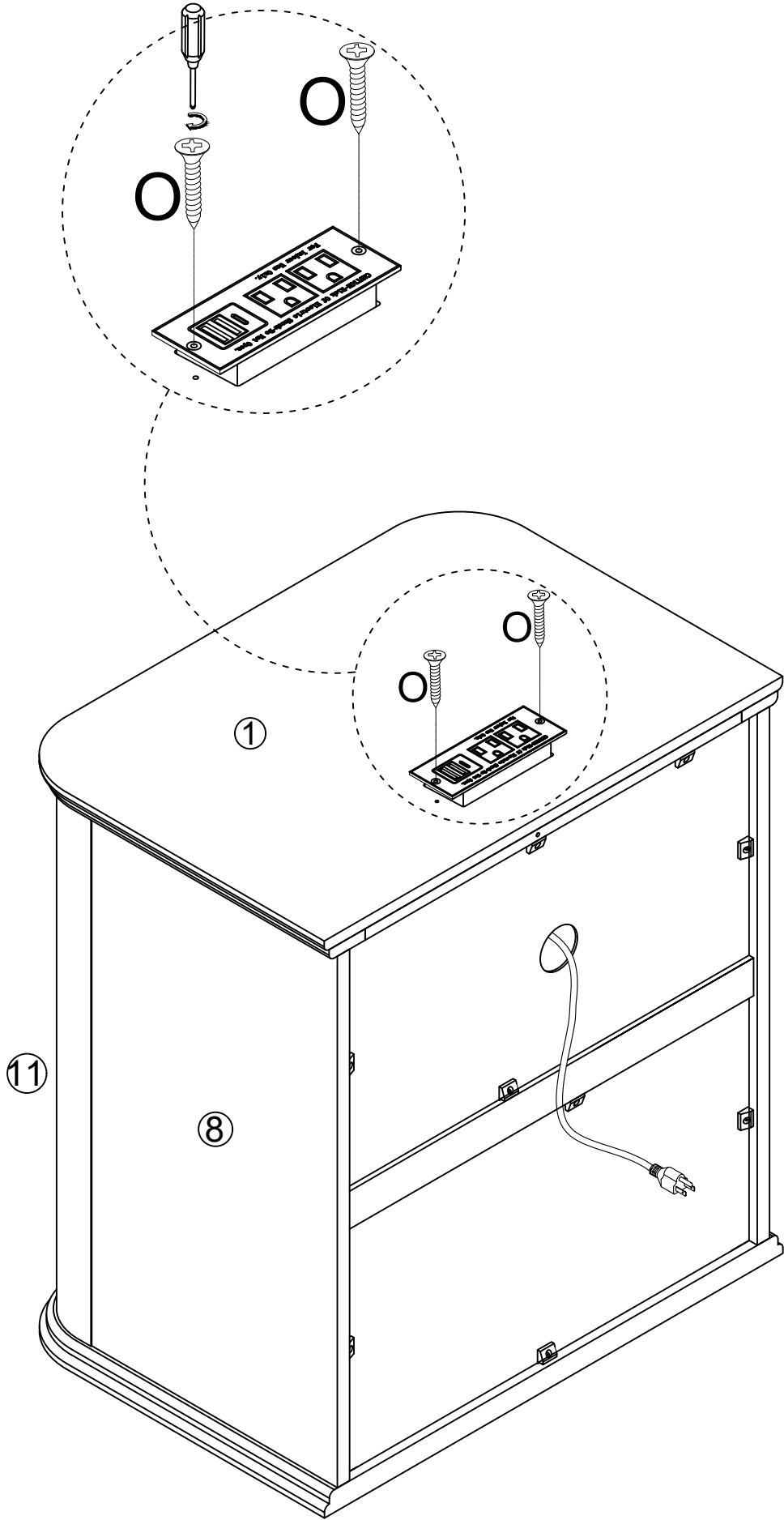

# Step 19

O

X2

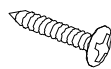

# Step 20

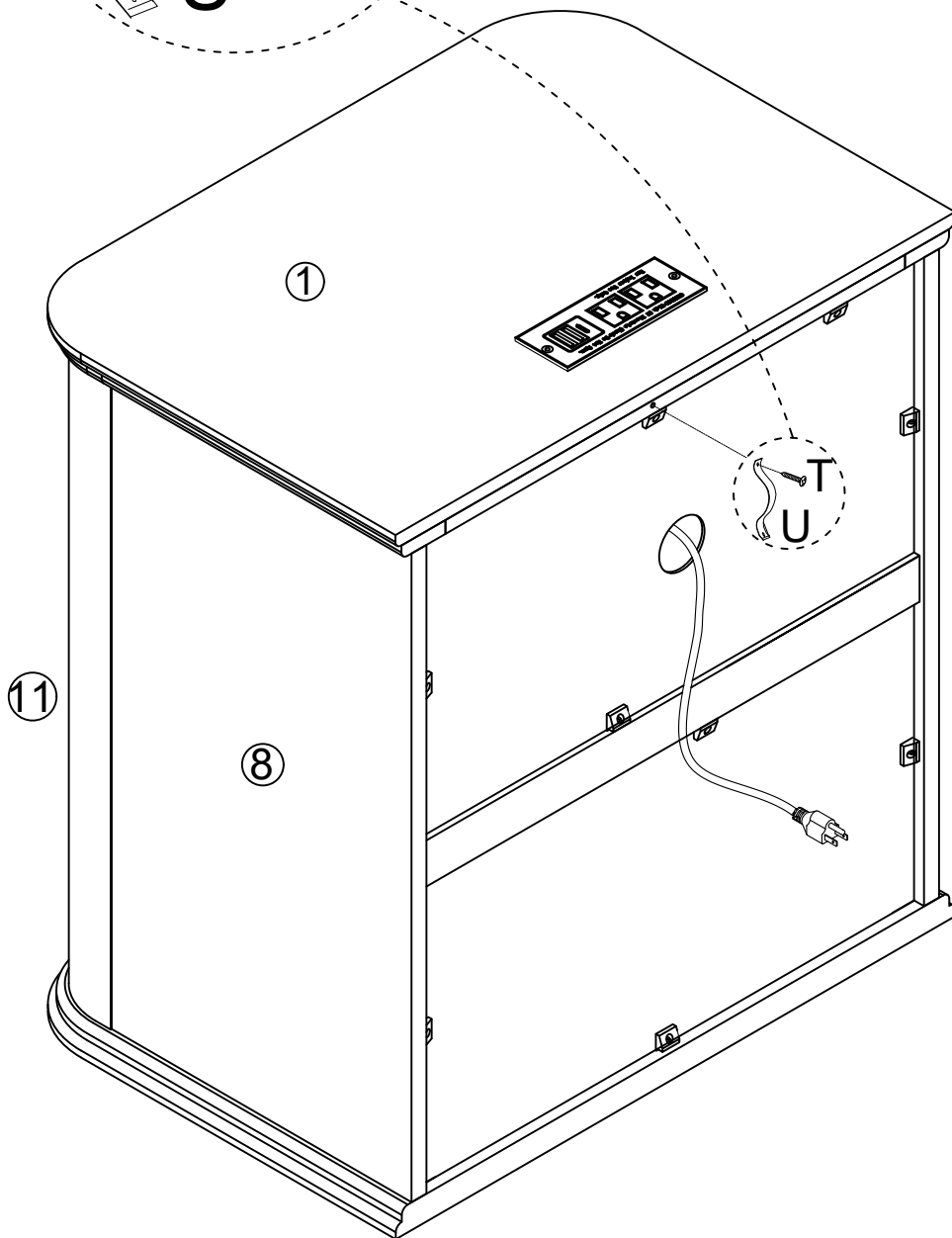
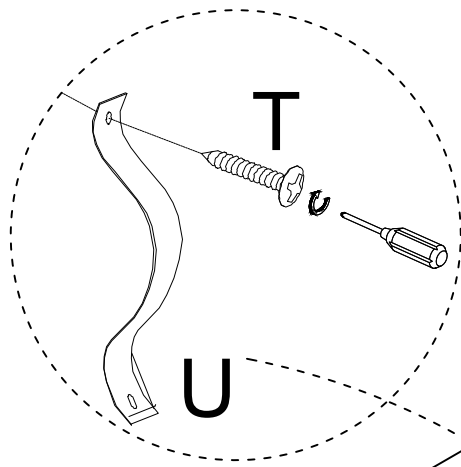
T	U
	
X1	X1



# Step 21

MAKE HOLES 45MM DEEP

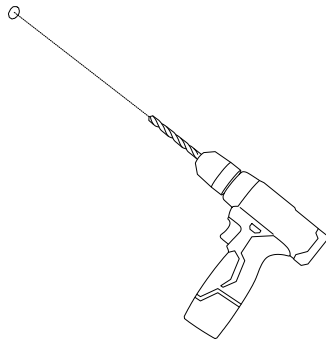

Wall

# Step 22

V

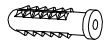

X1

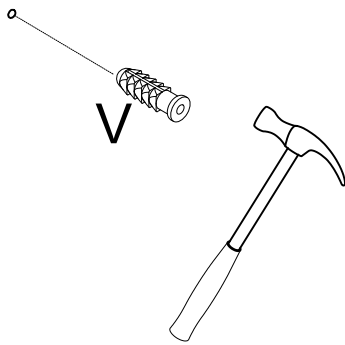

V

Wall

# Step 23

S



X1

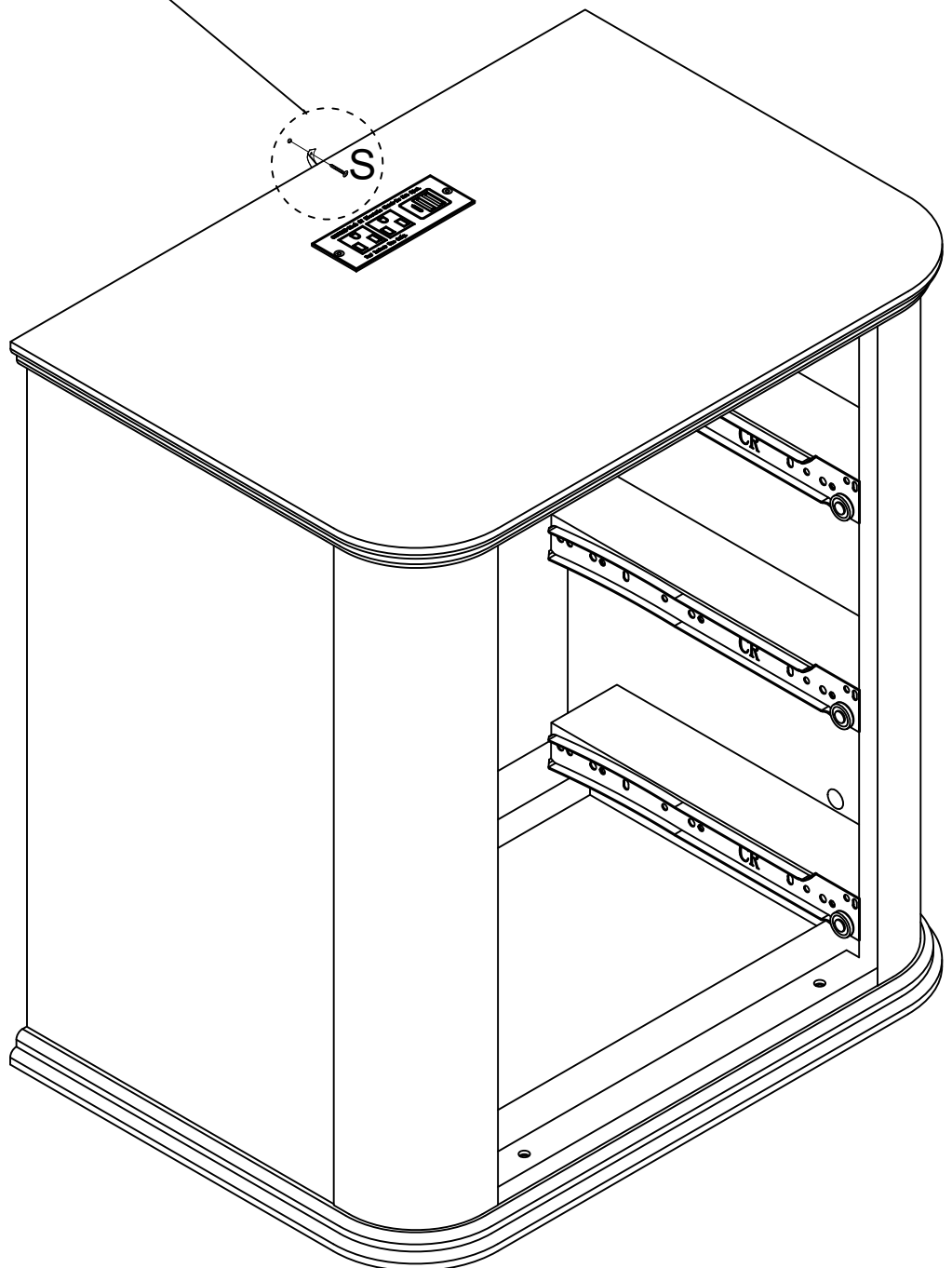
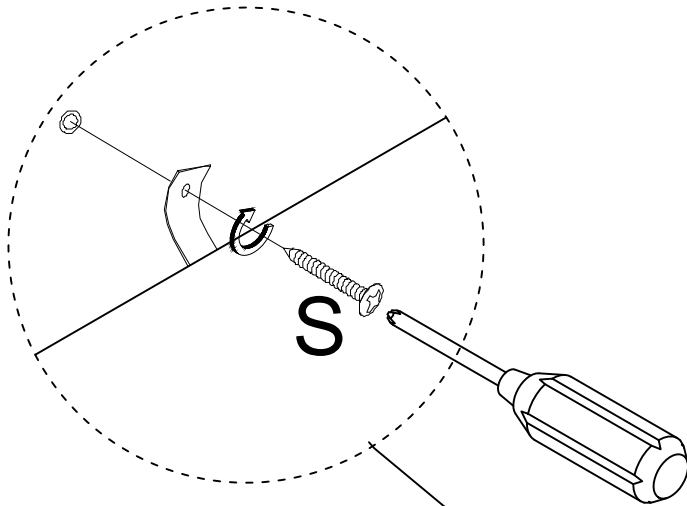

# Step 24

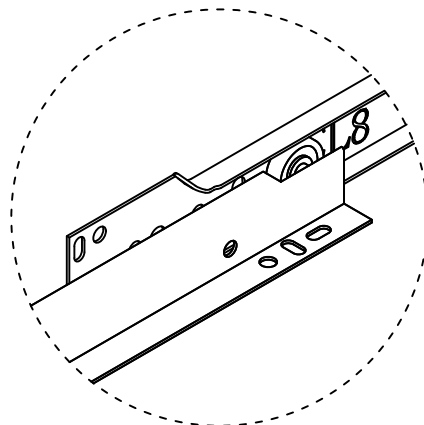
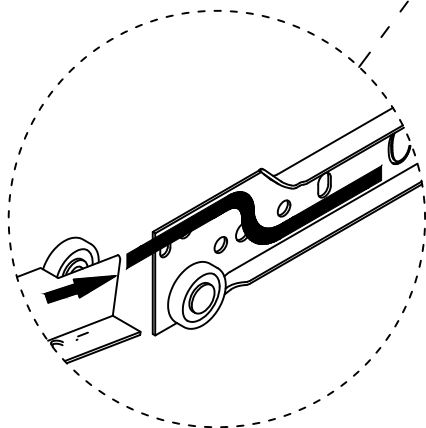
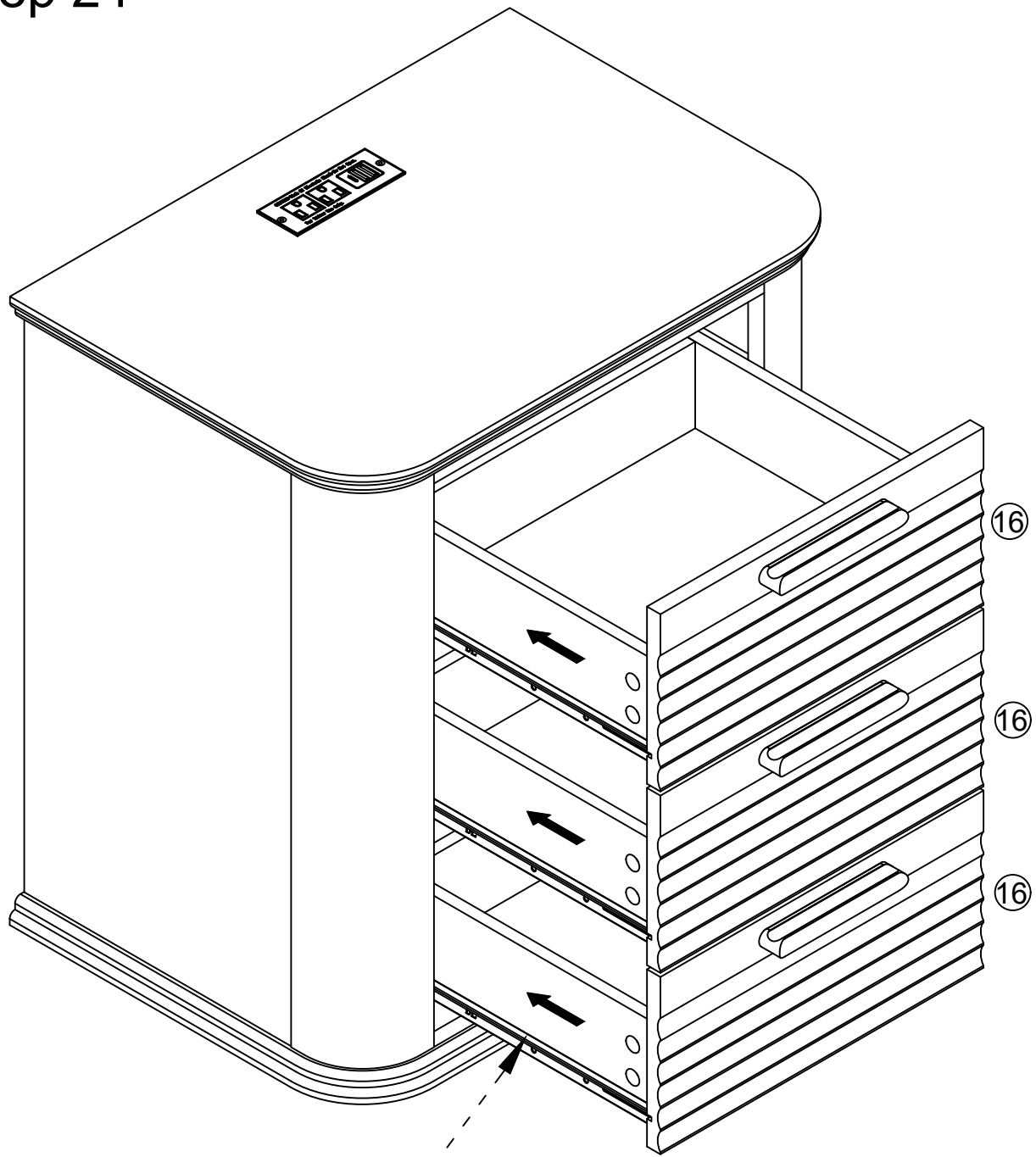

## Step 25

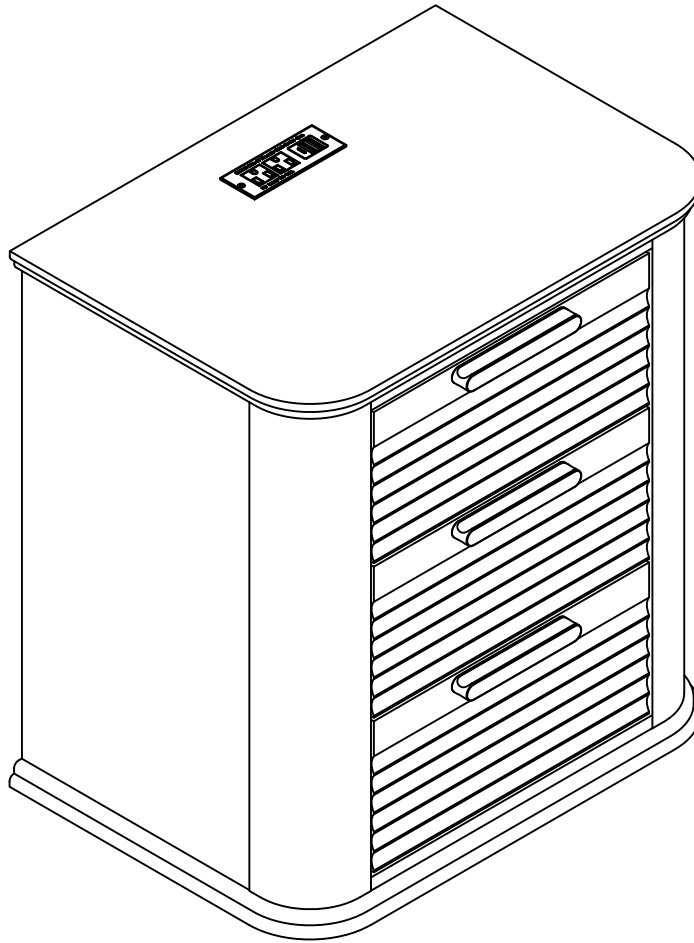

## Step 26

### **WARNING**



Children have died from furniture tipover. To reduce the risk of furniture tipover:

- **ALWAYS** install Anti-tip device provided.
- **NEVER** put a TV on this product.
- **NEVER** allow children to stand, climb or hang on drawers, doors, or shelves.
- **NEVER** open more than one drawer at a time.
- Place heaviest items in the lowest drawers.