









Assembly Instruction

PartsList			
Item	Description	Part	Qty Pcs
1	Table Top		1
2	Table base		1
3	Leg		1
4	Leg		1

HardwareList			
Item	Description	Part	Qty Pcs
A	Allen Wrench		1
B	Bolt		10
C	Spring washer(ø8)		10
D	Metalwasher		10

- 1、 Please check all items against the product list to ensure nothing is missing. Contact us at any time if any parts are not included.
- 2、 Before installation, place the packing foam from the box or prepare a thick cushion on the floor to protect the mirrored surface from scratches.

STEP 1

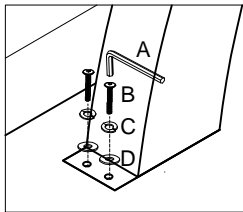

Place two screws inside before starting to tighten them



Tighten the screws to 80% tightness

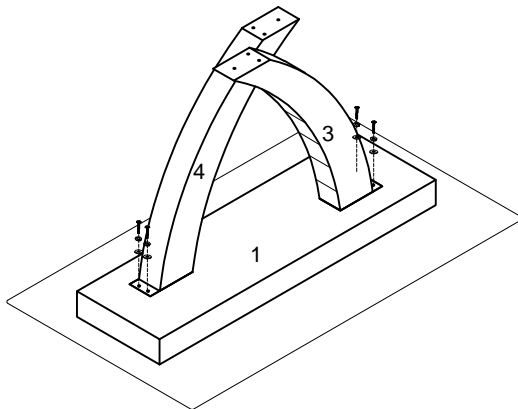

Place EPS or blankets underneath the product to prevent damage to the mirror surface

Two people work together to lift the top and slowly flip it over

STEP 2

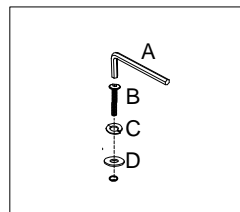

Place six screws inside at one time before starting to tighten them



Adjust the table balance then tighten all the screws to 100% tightness

