





# ASSEMBLY INSTRUCTIONS

Thank you for purchasing this quality product . Be sure to check all packaging material carefully for small parts that may have come loose inside the carton during shipment .



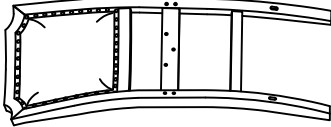
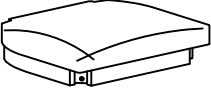
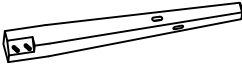

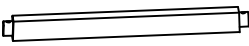

**"Hardware is attached underneath the seat bottom"**

This product will take 15-20 minutes to assemble

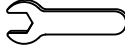
## Components List :

| NO | DESCRIPTION            | SKETCH   | QTY |
|----|------------------------|--|-----|
| A  | Back Rest              |    | 1pc |
| B  | Cushion Seat           |    | 1pc |
| C  | Front Leg (Left)       |    | 1pc |
| D  | Front Leg (Right)      |    | 1pc |
| E  | Side Stretcher (Left)  |  | 1pc |
| F  | Side Stretcher (Right) |   | 1pc |
| G  | Front Stretcher        |  | 1pc |

## Hardware List :

| NO | DESCRIPTION   | SIZE        | SKETCH   | QTY   |
|----|---------------|-------------|--|-------|
| 1  | Allen Key     | 58x23x4 mm  |  | 1pc   |
| 2  | Wrench        | 12x75 mm    |  | 1pc   |
| 3  | Short Bolt    | 1/4" x38 mm |  | 3pcs  |
| 4  | Long Bolt     | 1/4" x75 mm |  | 4pcs  |
| 5  | Hex-Nut       | 5/16"       |   | 4pcs  |
| 6  | Spring Washer | 5/16" x Ø12 |   | 11pcs |
| 7  | Flat Washer   | 5/16" x Ø19 |   | 11pcs |
| 8  | Wood Screw    | Ø8 x 50 mm  |  | 6pcs  |

**Screw driver is require for assembly (not included)**

### Reminders

1. Use only the hardware supplied.
2. Once the chair is finished, level and tighten all the bolts.
3. Do not over-tighten bolts.
4. This item may require periodic tightening.

### NOTE :

1. Hardware pack is located underneath the Cushion Seat (B).
2. Two or more people are needed for assembly. Please keep all hardware parts out of the reach of children.

# ASSEMBLY INSTRUCTIONS

Grab hardware bag from underneath the Cushion Seat.  
Do not fully tighten bolts until the Product is level  
and the assembly of the product is completed.

## Fig.1

Step 1: Lay the Backrest (A) on a flat soft surface, use Short Bolt (3), Spring Washer (6), Flat Washer (7) and Allen Key (1) to attached the Cushion Seat (B) to Backrest (A) as shown in Fig. 1.

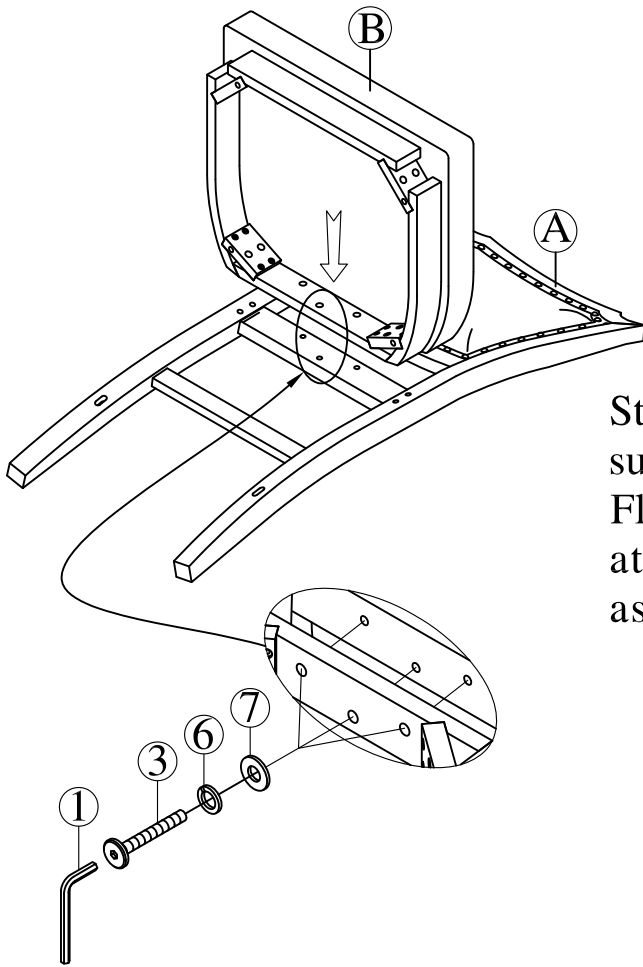

## Fig.2

Step 2 : Use Long Bolt (4), Spring Washer (6) Flat Washer (7) and Allen Key (1) to attached the Cushion Seat (B) to Chair Backrest (A) as shown in Fig. 2 . Do not fully tighten bolts yet.

Note: move seat back and forward to ease the finding of the hole in the corner block.

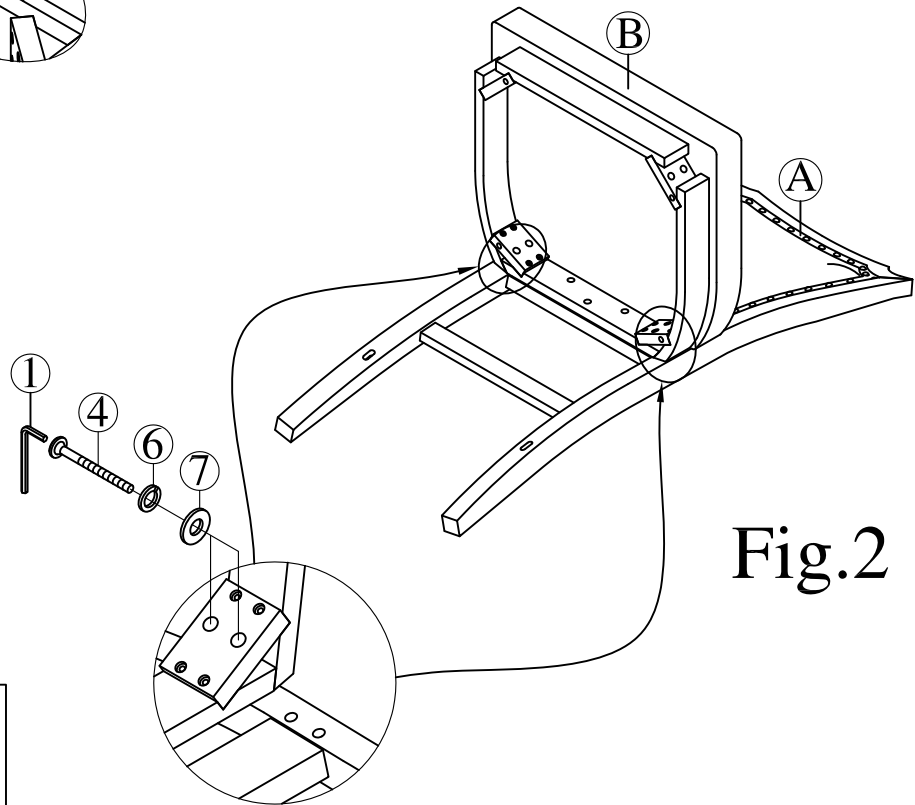

# ASSEMBLY INSTRUCTIONS

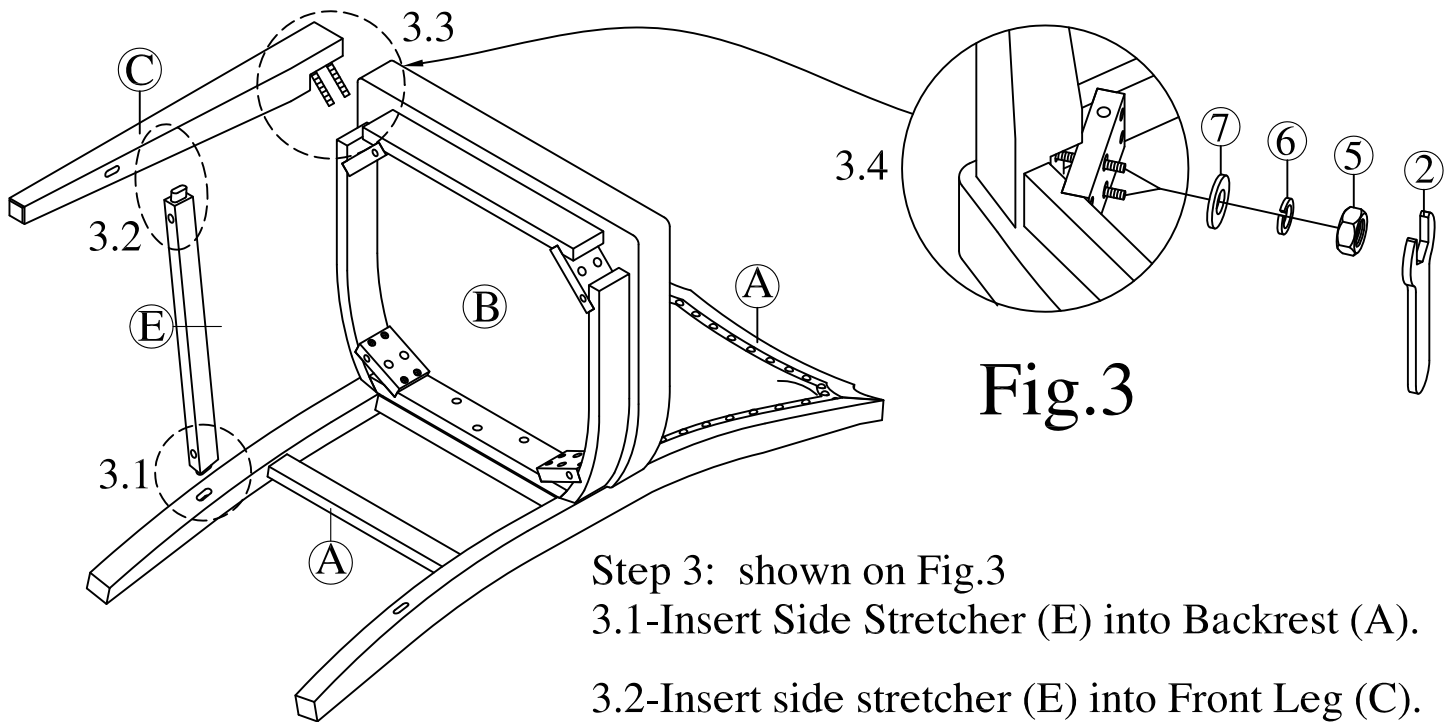

Fig.3

Step 3: shown on Fig.3

3.1-Insert Side Stretcher (E) into Backrest (A).

3.2-Insert side stretcher (E) into Front Leg (C).

3.3- Insert Front Leg (C) into Cushion Seat (B).

3.4- Use Hex-Nut (5), Spring Washer (6), Flat Washer (7) and tighten with Wrench (2) to attach Front Leg (C) to Cushion Seat (B). Do Not Fully Tighten Bolts Yet

Fig.4

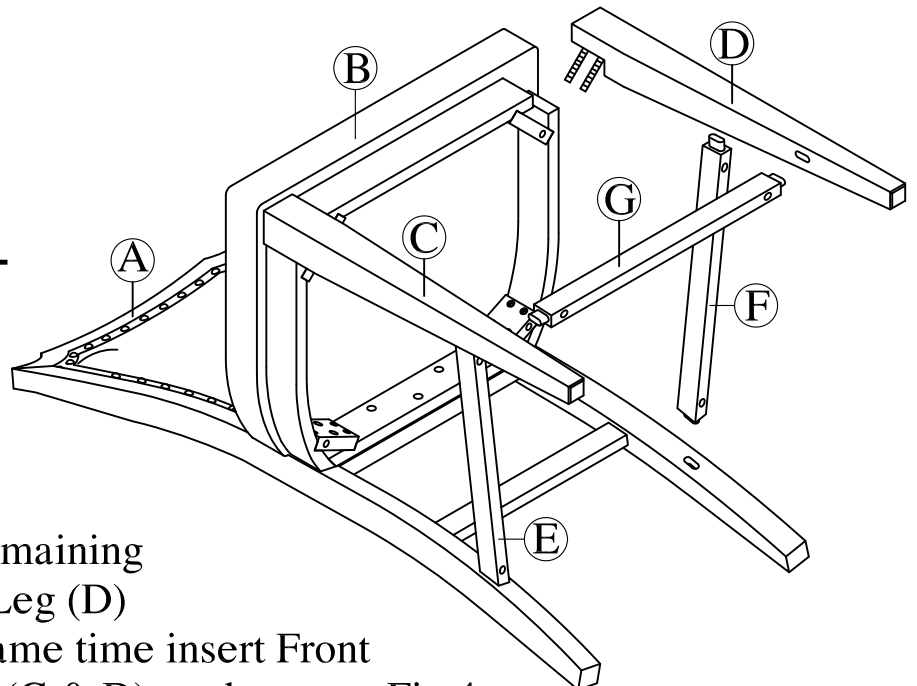

Step 4.

Repeat step 3 to attach the remaining Side Stretcher (F) and Front Leg (D) to Cushion Seat (B). At the same time insert Front Stretcher (G) into Front Legs (C & D) as shown on Fig.4.

# ASSEMBLY INSTRUCTIONS

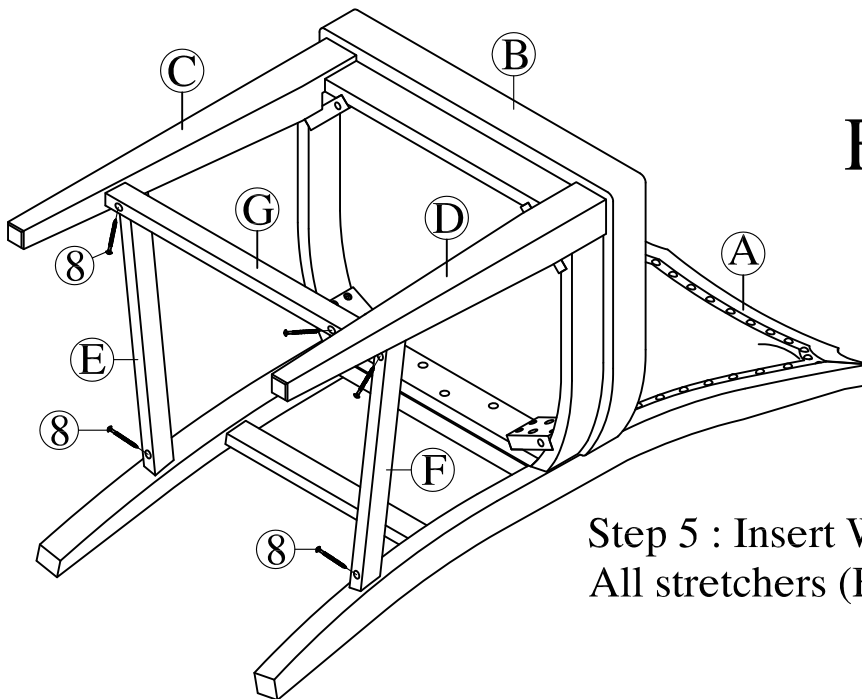

Fig.5

Step 5 : Insert Wood Screw (8) to fasten All stretchers (E, F, G) as shown on Fig. 5.

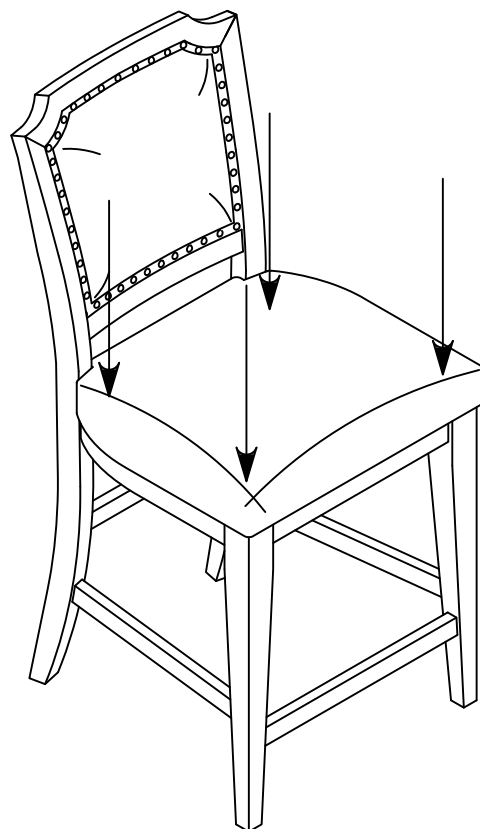

Fig.6

Step 6: Place the loosely assembled chair on a hard flat surface and apply gentle downward pressure on the seat. As shown on Fig.6. Once the chair is balanced and leveled, fully tighten all bolts.

**Assembly is now Complete**