

# Assembly | Asambla | Assemblage

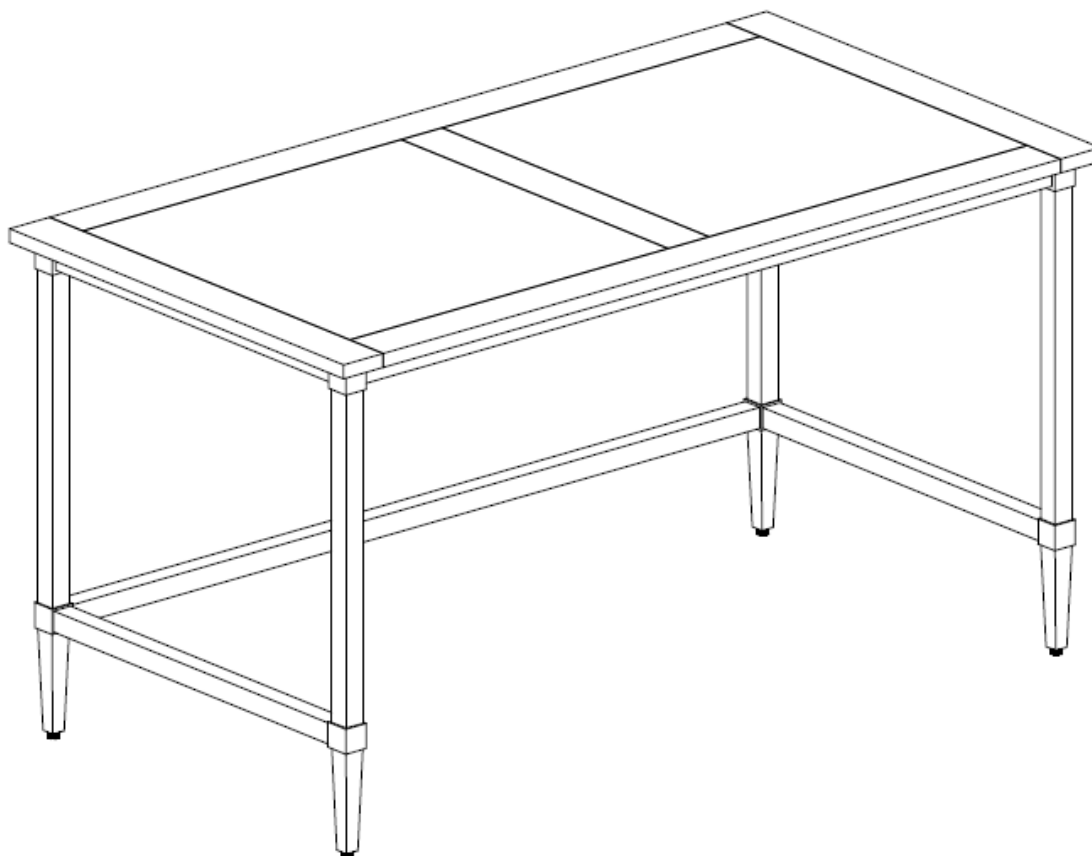

# Assembly | Asambllea | Assemblage

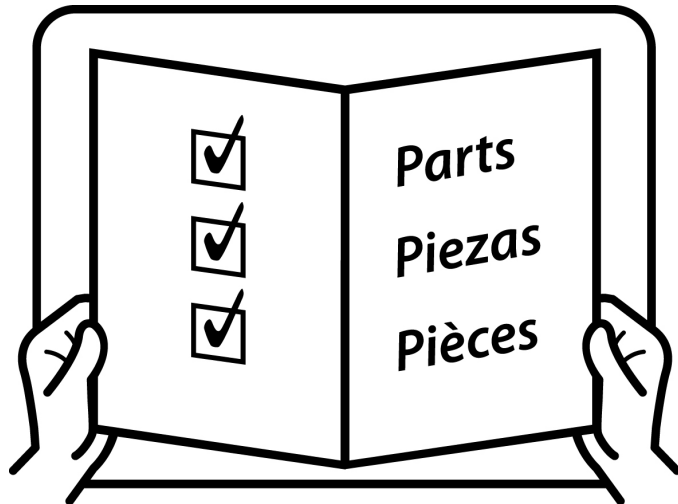
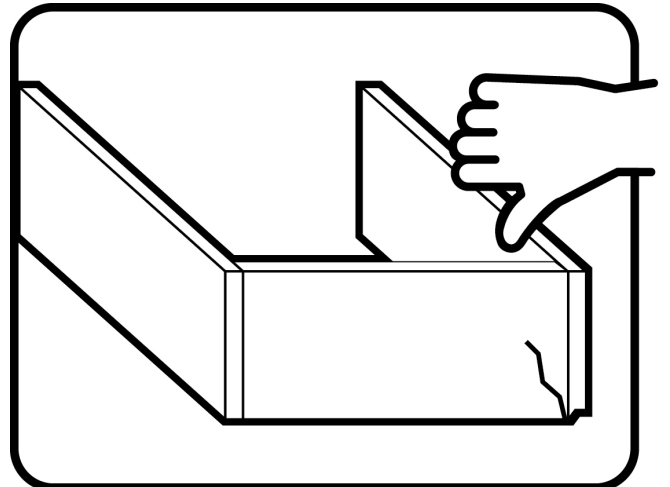
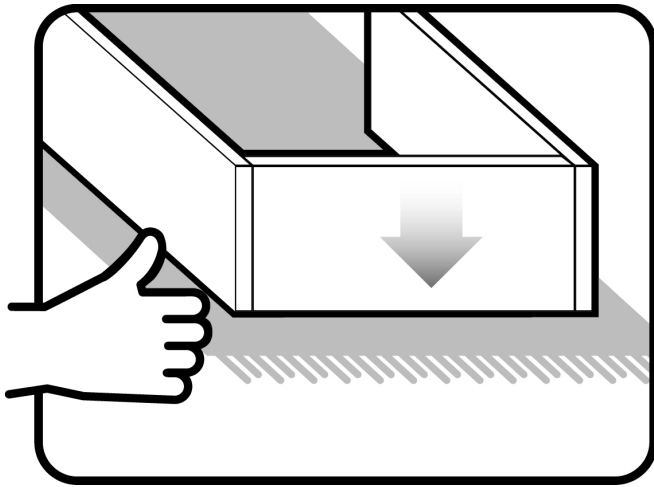
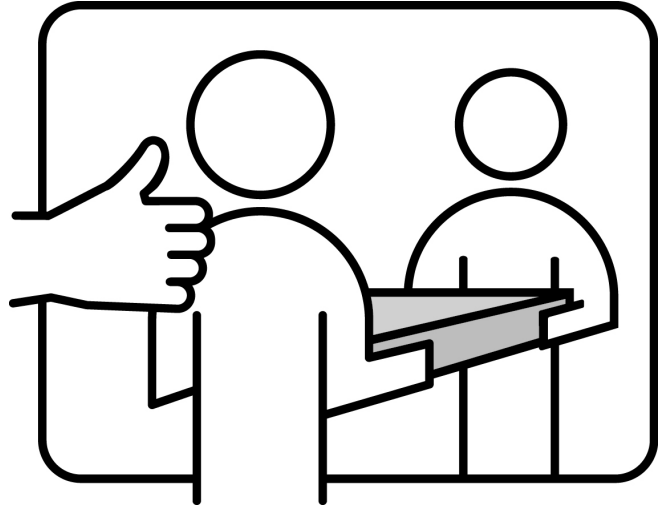
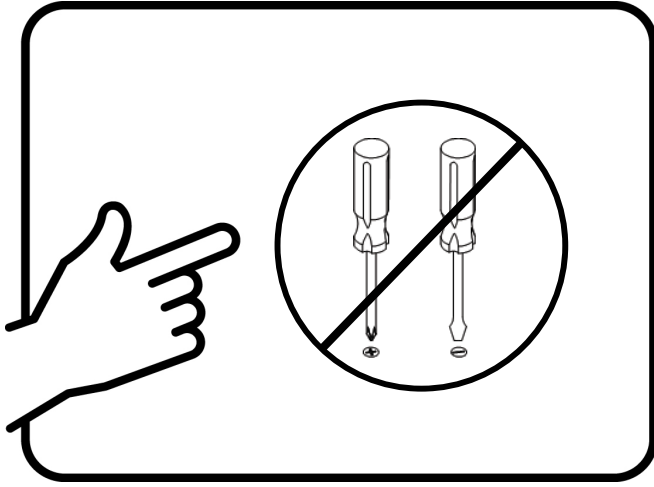

# Assembly | Asamblea | Assemblage

Techniques | Técnicas | Techniques

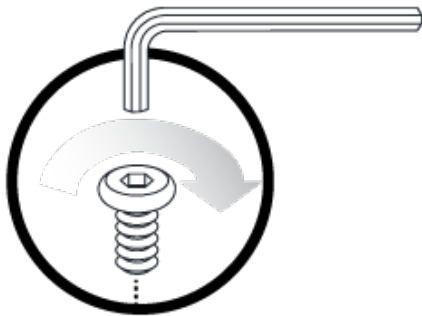

Care | Cuidado | Entretien

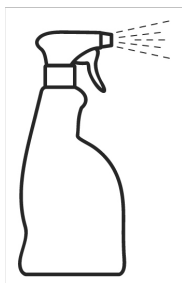









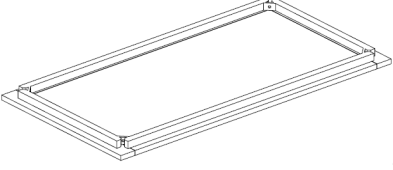

Safety | Seguridad | Sécurité



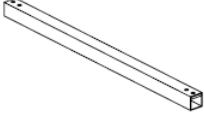
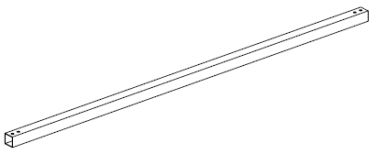



Note! | ¡Nota! | Remarque!



# Assembly | Asamblea | Assemblage

<p>A <span style="float: right;">x1</span></p>  <p>Tabletop Mesa Dessus de la table</p>	<p>B <span style="float: right;">x1</span></p>  <p>Leg Pierna Jambe</p>	<p>C <span style="float: right;">x1</span></p>  <p>Leg Pierna Jambe</p>
<p>D <span style="float: right;">x1</span></p>  <p>Leg Pierna Jambe</p>	<p>E <span style="float: right;">x1</span></p>  <p>Leg Pierna Jambe</p>	<p>F <span style="float: right;">x2</span></p>  <p>Crossbar Travesaño Barre transversale</p>
<p>G <span style="float: right;">x1</span></p>  <p>Crossbar Travesaño Barre transversale</p>	<p>1 <span style="float: right;">x8</span></p>  <p>Bolt Tornillo Boulon <span style="float: right;">8/32" x 13/32" L</span></p>	<p>2 <span style="float: right;">x1</span></p>  <p>Allen wrench Llave allen Clé allen <span style="float: right;">4/32"</span></p>
<p>3 <span style="float: right;">x4</span></p>  <p>Flat washer Arandela plana Rondelle plate</p>	<p>4 <span style="float: right;">x4</span></p>  <p>Spring washer Arandela de resorte Rondelle à ressort</p>	<p>5 <span style="float: right;">x4</span></p>  <p>Bolt Tornillo Boulon <span style="float: right;">5/16" x 1-9/16" L</span></p>

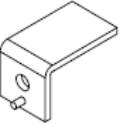
# Assembly | Asamblea | Assemblage

<p>6</p>  <p>Allen wrench Llave allen Clé allen</p> <p>10/32"</p> <p>x1</p>	<p>7</p>  <p>Bolt Tornillo Boulon</p> <p>8/32" x 31/32" L</p> <p>x4</p>	<p>8</p>  <p>Bolt Tornillo Boulon</p> <p>8/32" x 19/32" L</p> <p>x2</p>
<p>9</p>  <p>Bracket Soporte Support</p> <p>x2</p>	<p>10</p>  <p>Allen wrench Llave allen Clé allen</p> <p>5/32"</p> <p>x1</p>	

**Note:** Screw in bolts 80% until step 3

**Nota:** Atornille los pernos 80% hasta el paso 3

**Remarque:** vissez les boulons à 80% jusqu'à l'étape 3.

# Assembly | Asambla | Assemblage

1

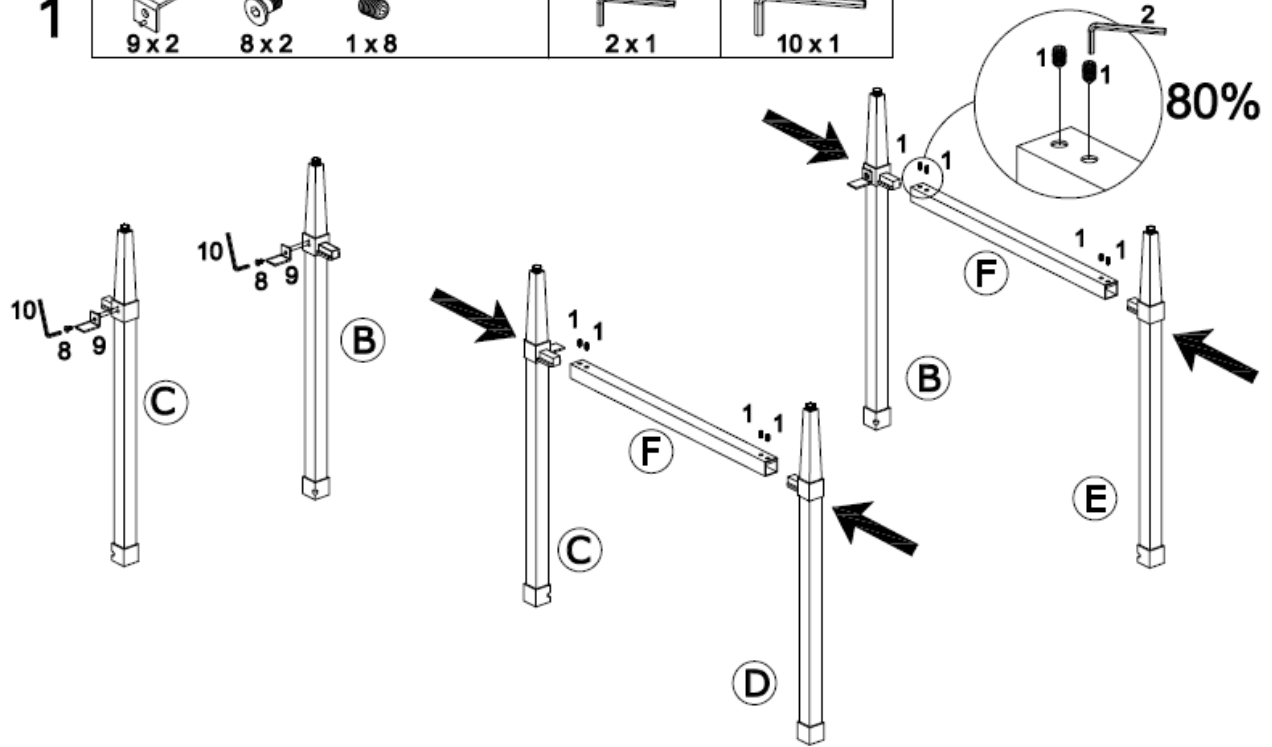

2

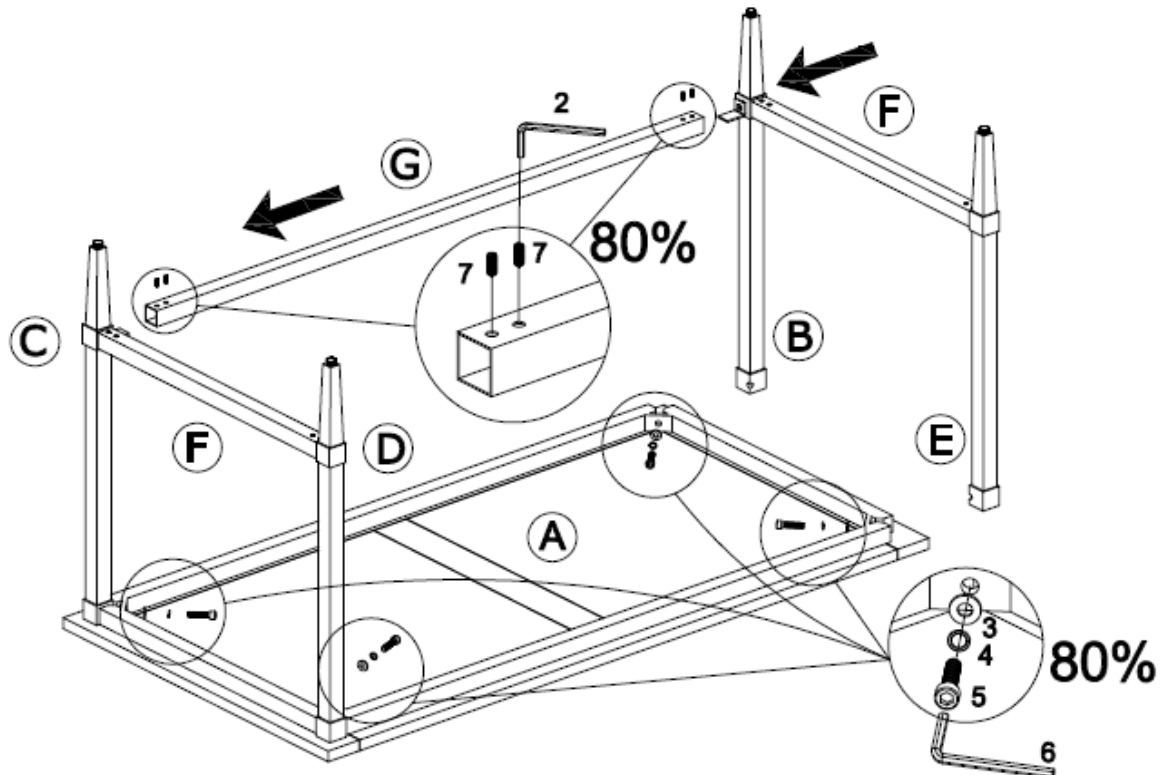

# Assembly | Asambla | Assemblage

3

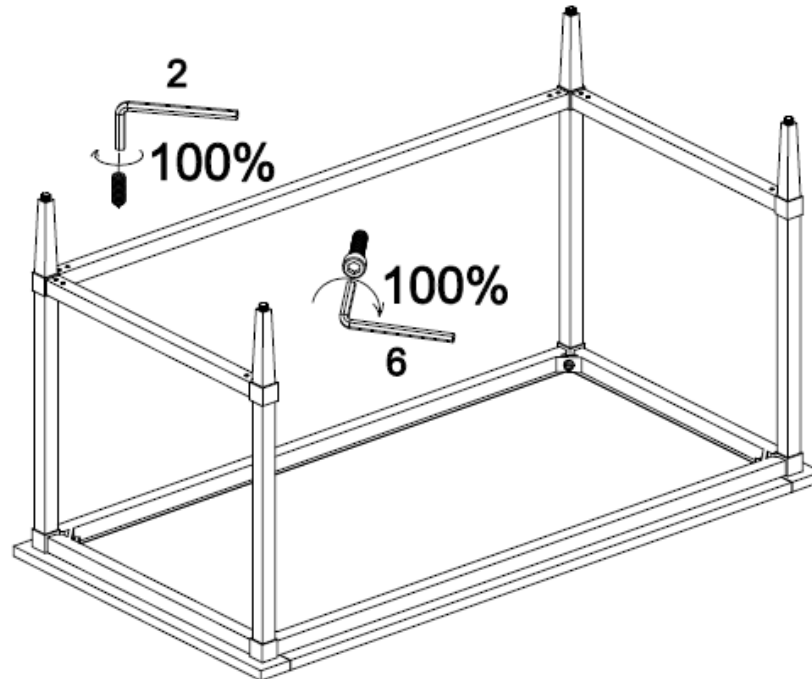

**Note:** Screw in bolts 100%

**Nota:** Atornille los pernos al 100%

**Note:** Visser les boulons 100%

4

