

6-TIER HEAVY-DUTY SHELVING

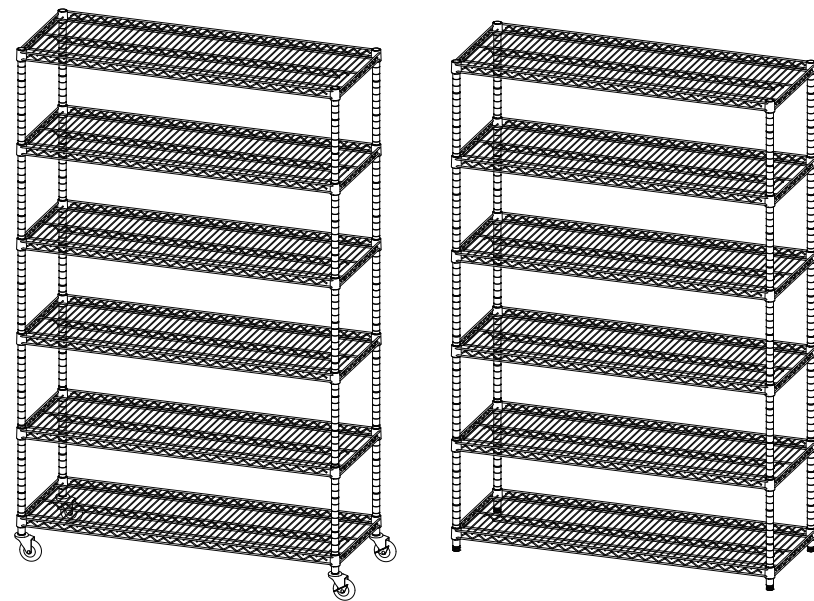

Warning:

Maximum weight capacity per shelf is 1000lbs when equally distributed on feet levelers.
Maximum entire unit weight capacity is 600lbs when equally distributed on wheels.

Failure to follow these instructions may result in serious injury or death of yourself and people around you. Some of the part are heavy and/or has shape edge, please install it carefully to avoid hurt you and people around you.

Caution:

Do not stand on or climb on the shelving unit. Place heavier items on lower shelves and lighter ones on top shelves.

PACKAGE CONTENTS Attention: Please install it with 2 people !

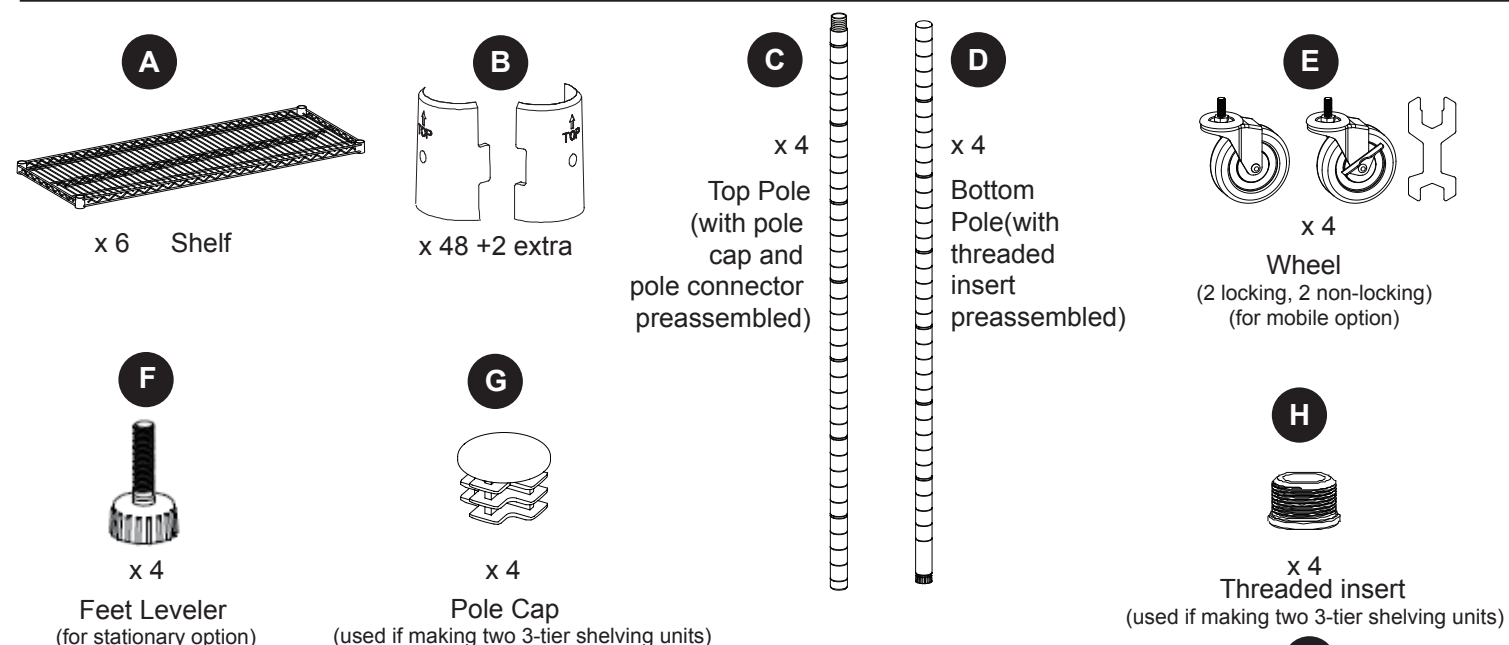

HARDWARE CONTENTS

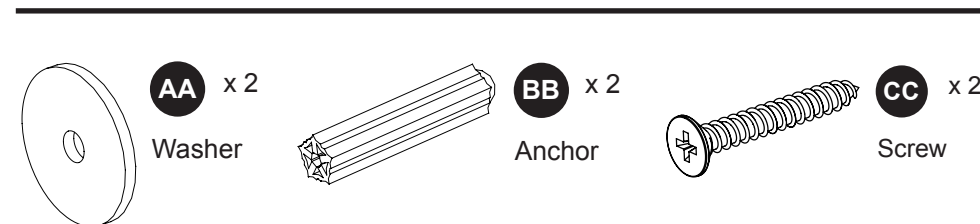

(NOTE: Discard the black plastic spacers I. These between each shelf are only for packing purpose, not for assembling.)

ASSEMBLY INSTRUCTIONS

1. Stationary Option: Screw each feet leveler (F) into the bottom of each bottom pole (D). Turn clock-wise to screw in place.

Mobile Option: Screw each wheel (E) into the bottom of each bottom pole (D). Turn clock-wise to screw in place.

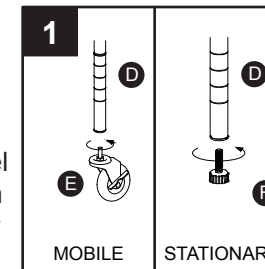

Attention: The wheel (E) must be fully screwed to the bottom pole (D) by wrench

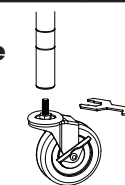

2. With the tapered end facing up, snap the two halves of a tapered lock (B) at the desired height on bottom pole (D). Repeat for the remaining bottom poles (D), making sure the tapered locks (B) are installed at the same grooved line on each bottom pole (D).

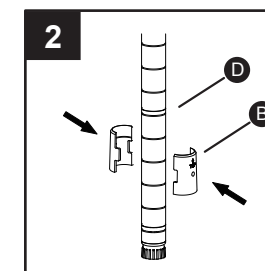

Attention : The tapered must be fixed to the groove on the pole, and make sure the tapered does not slip before installing the shelf

3. Rest shelf (A) on its side, then insert the bottom poles (D) through the corner holes of the shelf (A).

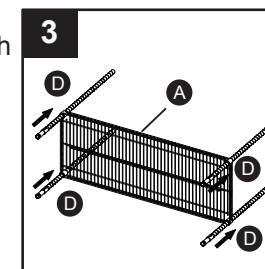

4. Turn assembly upright and push the shelf (A) firmly onto the tapered locks (B). Note: Make sure the lip of shelf (A) is facing down and the levelers (F) on bottom poles (D) are on the floor.

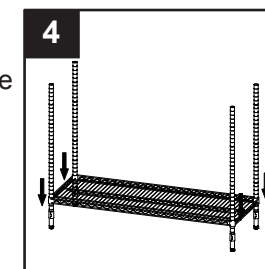

5. Repeat steps 2-4 for the second shelf (A).

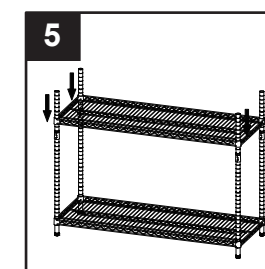

6. Screw top pole (C) onto bottom pole (D). Hand tighten.

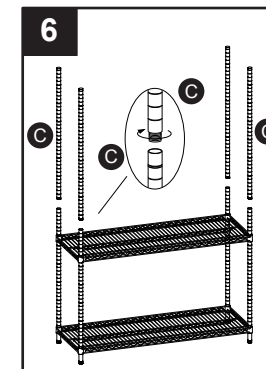

7-1. Repeat steps 2-4 for the remaining shelves (A). Refer to image 7-1 for the assembled unit of stationary option.

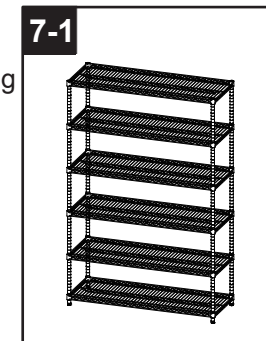

7-2. Repeat steps 2-4 for the remaining shelves (A). Refer to image 7-2 for the assembled unit of mobile option.

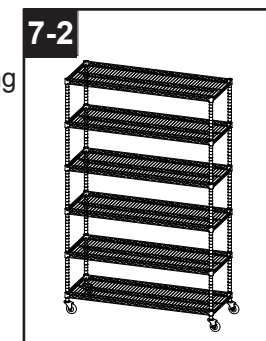

8. OPTIONAL: Screw each threaded insert (H) into the bottom of each top pole (C). Repeat 1-4 to make a 3-tier shelving unit with wheel (E). Insert each pole cap (G) into the top of each bottom pole (D). Repeat 1-4 to make another 3-tier shelving unit with feet leveler (F).

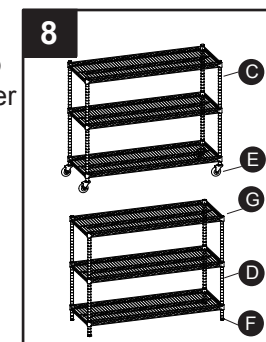

9. OPTIONAL: Move unit to desired location and mark spot through top shelf wire on each side of unit. Drill 1/4 in. holes at each marked spot, then insert plastic anchors (BB) into holes. Insert screws (CC) through the washers (AA) then through the back of the top shelf wire and into the plastic anchors (BB).

