

A. Seat Cushion-1PC

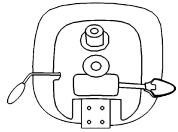

F. Cator-5PCS



B. Backrest-1PC



G. Screw-4PCS



C. Back Support w / Arms-1PC

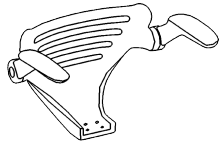

H. Screw -4PCS



D.



I. Allen key-1PC



D1. Footring+Heigh Adj. Knob

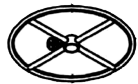

J. Cap Cover-2PCS



E. Base-1PC

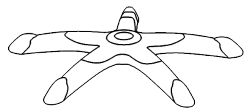

K. Cap Cover-2PCS



Step 1

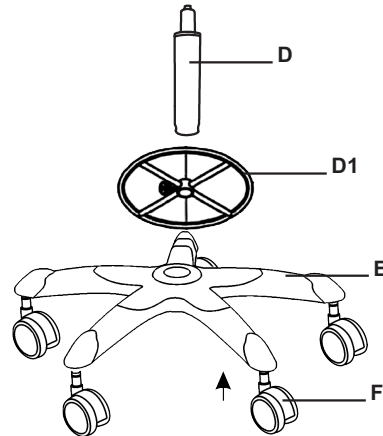

Set the base (E) upside down, insert castors (F). Flip the base (E) upright, insert the pneumatic cylinder (D) with (D1) into the center hole on the base (E).

Step 2

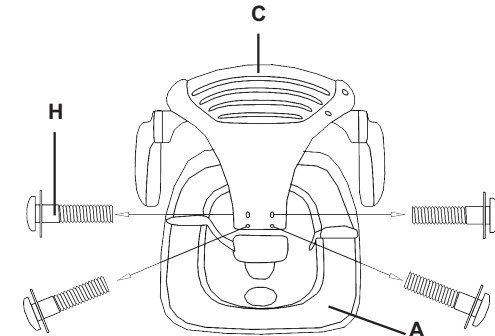

Secure the Back Support w / Arm (C) onto Seat Cushion (A) using Screws (H).

Step 3

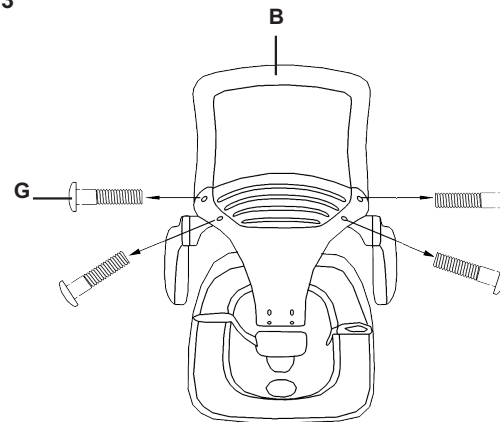

Secure Backrest (B) onto Back Support w / Arm (C) with Screws (G)

Step 4

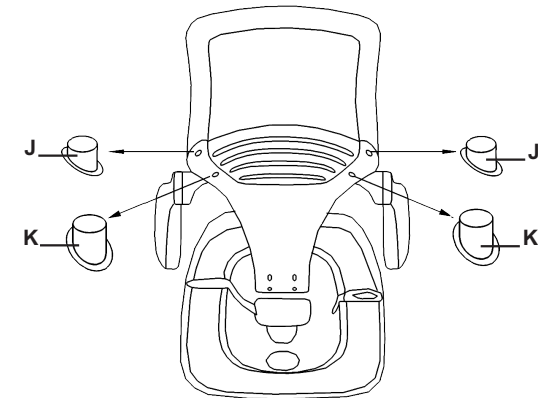

Cover the Screws' holes on the Back Support w / Arms (C) with Cap Cover (J) and (K).

KEEP THIS PAGE FOR FUTURE REFERENCE.