

12' x 20' Solar-Powered LED Lights Outdoor Aluminum Pergola

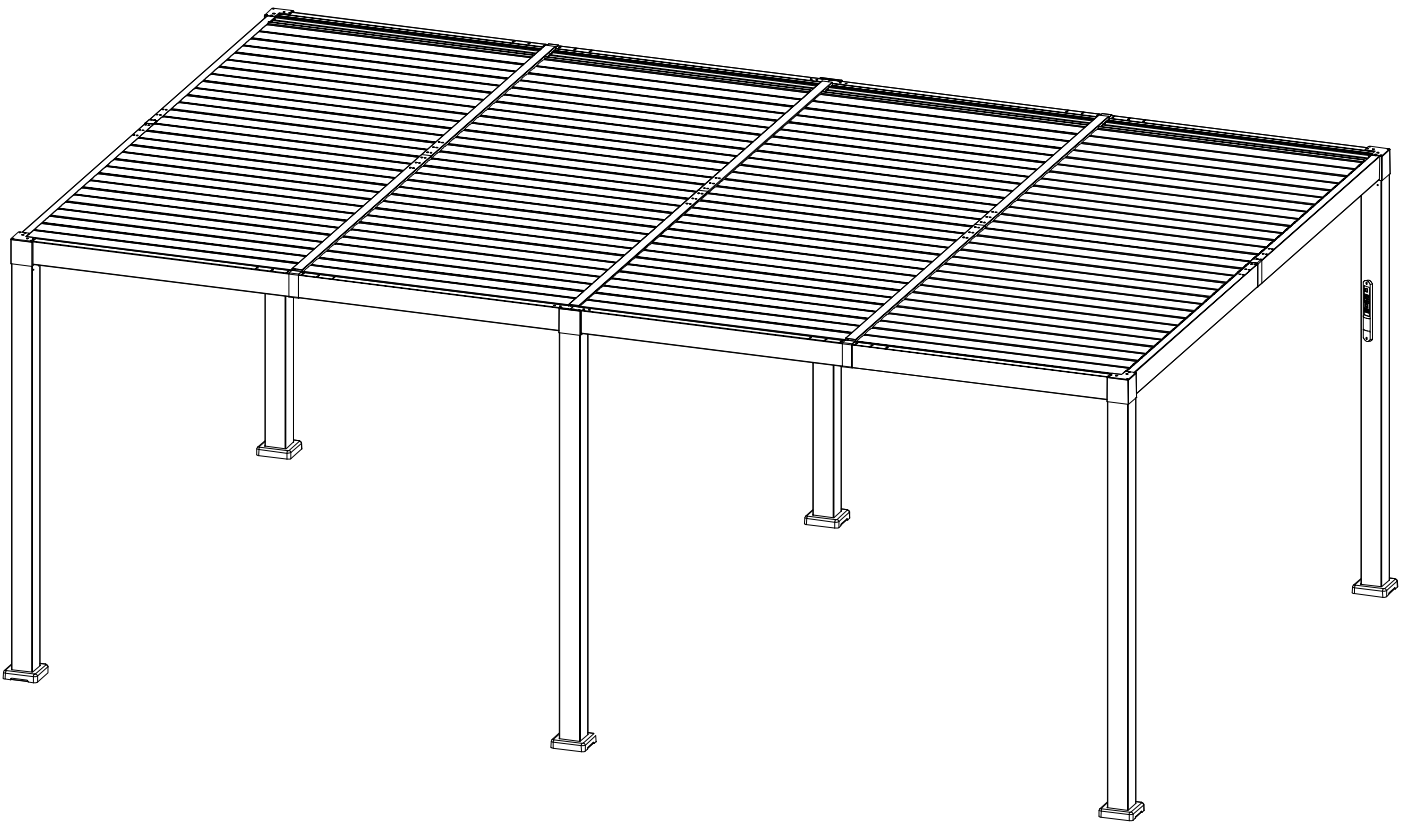

Need help or have any questions? Our Professional Service Team is ready to assist you. Don't hesitate to reach out to us at service@usavingmall.com or call us at **978-300-3837** for any support or further assistance. We are committed to providing excellent service.

User Manual

General Guidelines:

- Please read the following instructions carefully and use the product accordingly.
- Please keep this manual and hand it over when you transfer the product.
- This summary may not include every detail of all variations and considered steps. Please contact us when further information and help are needed.
- Any questions, please contact our customer service.

Notes:

- Personal injury and/or damage to the product may occur if the product is used outside of its intended purposes and/or if the product has been changed/modified from its original design.
- The product must be assembled and used in accordance with the provisions of the manual. The seller does not assume any responsibility or liability with respect to any damage caused by incorrect assembly or improper use.
- Carefully check accessories when opening the package. If anything is missing or damaged, please contact us immediately.
- Please do not force or overtighten screws. If any screw gets stuck, unscrew it and start again. After setup, fully tighten screws.
- Please keep all the packaging - we cannot accept any returned item without the original packaging.
- Please ensure that you have sufficient space to assemble the item.
- Do not tighten all the screws before ensuring the item is properly aligned.
- Ensure that the outdoor aluminum pergola is installed in a suitable location with adequate space and proper support.
- It is recommended to assemble the pergola with the help of at least three people to ensure safety and efficiency. The use of a ladder and power tools can greatly increase installation efficiency.
- If you plan to use the pergola against a wall, adjust the direction of the post metal caps during assembly.
- Keep small parts and hardware in a safe place during assembly to avoid misplacement.
- Prior to initial use, expose the pergola to sunlight for 6-8 hours to ensure the batteries are fully charged.
- The LED lights controller allows for adjustable color temperature and brightness. Please ensure you follow the instructions provided for proper operation..
- If the LED lights are not functioning properly, such as not turning on, please contact our customer service team immediately for assistance.

Warnings:

- Keep children away when assembling the product. Small parts included in the package can be fatal if swallowed or inhaled.
- To avoid potential dangers of suffocation, please keep all parts and packaging (film plastic bags, foam, etc.) away from babies and children.
- Tighten all components securely before use. Failure to do so may result in personal injury.
- Ensure that the pergola is securely anchored or fastened to the ground or any supporting structure to prevent it from toppling over.
- Be cautious while handling any sharp edges or corners of the pergola during the assembly process.

Daily Maintenance:

- Regularly inspect the pergola for any loose or damaged parts and secure or replace them as needed.
- Clean the pergola using mild cleaning solutions and a soft cloth. Avoid using abrasive materials or harsh chemicals that could damage the aluminum surface.
- Keep vegetation and debris clear from the pergola to prevent any potential damage or obstruction.
- Regularly clean the surface of the solar panel and LED strip lights. Use a soft, lint-free cloth to remove dust and debris



Thanks for selecting our range!

We recommend taking the time to read the directions carefully before using this product - it'll help ensure it runs correctly and lasts longer. Plus, be sure to check out the safety warnings before you start. Once you're done reading, please keep this guide handy for future reference.

Safety precautions:

- Warning Indicates a potentially hazardous situation that, if not avoided could result in death or serious injury.
- Avoid placing the product in a situation with extreme heat, pressure, puncture, or fire, beyond that specified in the instructions.
- Please do not disassemble or modify this product.
- Do not place this product near flammable or explosive items to charge.
- This product contains no repairable parts, so don't try to disassemble it or attempt repairs yourself.
- If it fails, reach out to the manufacturer or distributor for assistance. Additionally, only use the right charger to charge this product.
- Please charge before use.
- If you notice any changes, discoloration, or unpleasant odor on the product's shell, please discontinue use.
- The surface stains can be wiped clean with water and a soft cloth. Do not use harsh solvents.
- This product features a lithium battery, so please don't discard it - dispose of it responsibly in accordance with local laws.

Important Note: This model is designed specifically for controlling LED lights. Please ensure that the channel is set to "L" before using it. For any additional functionality, it is necessary to purchase the appropriate accessories.

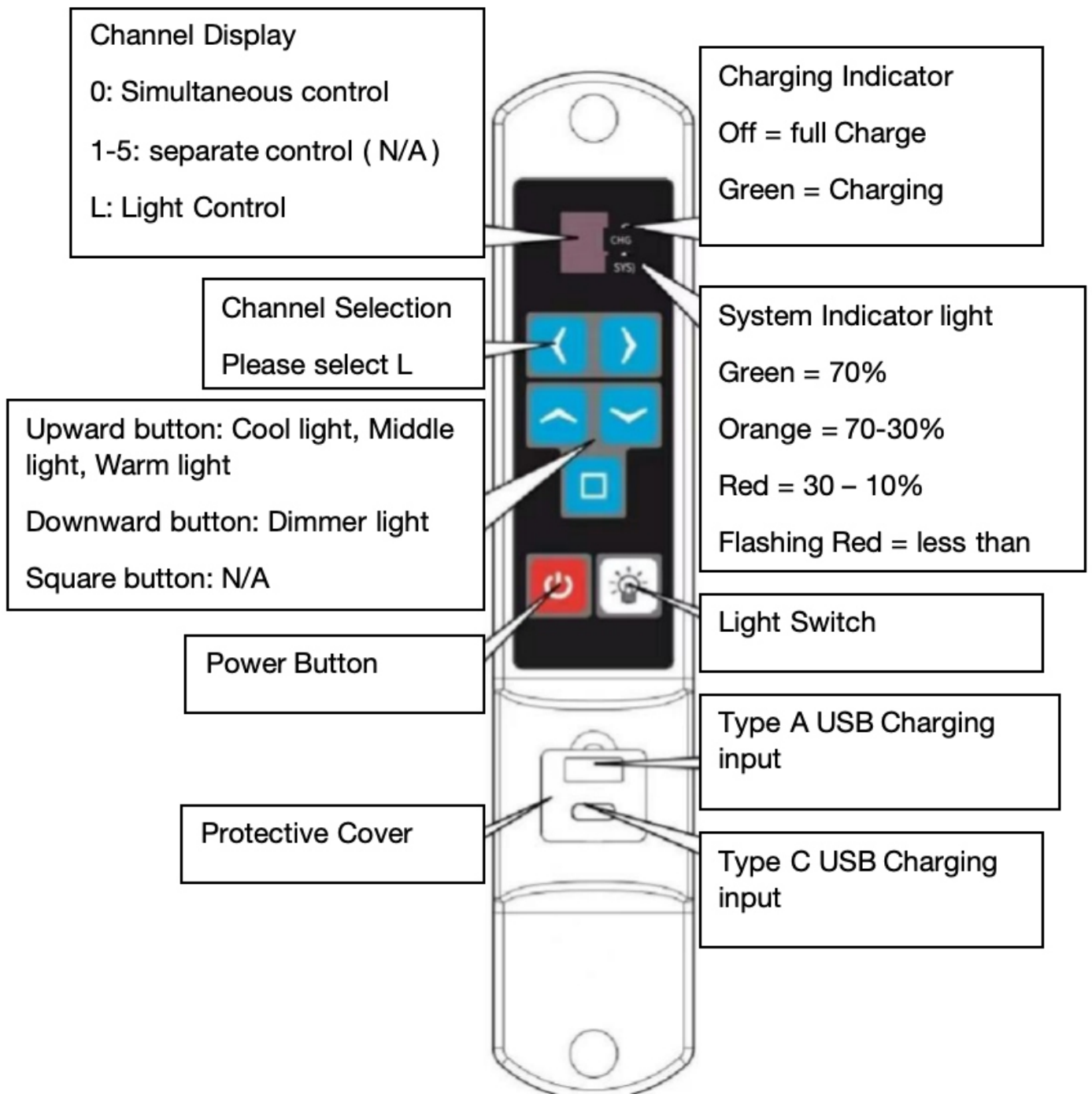

Important Note: This model is designed specifically for controlling LED lights. Please ensure that the channel is set to "L" before using it. For any additional functionality, it is necessary to purchase the appropriate accessories.

Charging the controller:

- Please charge it before use. The controller supports solar energy and external power charger.
- When charging with an external power supply, you can use a power bank or USB adapter to connect the USB type c to charge it.
- During charging the charging indicator light will be green. When fully charged or charge fault the indicator light goes off.
- The controller supports the QC2.0 fast charging input, and the maximum charging power is 15w.
- When connected to an adapter or power bank that supports the fast charge function, the fast charge function will greatly shorten the charging time.
- Tip: when the battery temperature is higher than 60 degree or lower than -5 degree the battery charging stops.

Turning on or off the power:

- To ensure that the internal battery power is not depleted during transportation, the power is turned off when you receive the goods. Long press the power button for 2 seconds, the power is turned on, at the same time the channel display shows the number 8, the SYS indicator light turns from red to green, and then hold the light for 2 seconds to indicate the current power and then enter the standby state. You can perform subsequent operations only after powering on the power supply.
- If you do not use the battery for a long time, turn off the power supply to prevent damage caused by deep discharge of the battery.
- Long press the power button for 2 seconds to turn off the power. At the same time the channel display shows O and F and the SYS indicator light turns from green to red, then off.
- Long-term non use refers to the time when solar charging cannot be carried out during transportation or under other circumstances. When installed normally, the solar panel uses outdoor light enough to replenish the energy consumed in standby mode, without the need to turn off the power.

Charging digital devices:

- The controller supports the following fast charge output protocols@
- DPS protocol (BC1.2, Apple, Samsung)
- Qualcomm QC2.0 and QC.3.0 fast charge protocol
- Huawei FCP fast charge protocol
- Samsung AFC Fast Charge Protocol
- When charging digital devices, please open the protective cover first, connect the USB A end of the charging cable to the charging output socket of the controller and the other end to the digital device.
- Press the power button to turn on the charging output for about 1 hour, it will be closed automatically. If you need to continue charging, please turn it on again.
- When the controller power is less than 30%, the output will be automatically shut down to ensure the normal operation of the other functions. Do not turn on the charging output again before the power is increased.

Important Note: This model is designed specifically for controlling LED lights. Please ensure that the channel is set to "L" before using it. For any additional functionality, it is necessary to purchase the appropriate accessories.

-
- After charging, please put back the protective cover immediately and press slightly to confirm the position. If the protective cover is not properly covered, the charging and discharging socket of the controller may be flooded which may damage the controller.
 - Any damage of this kind is not covered under the warranty.

Point control module code:

- The point control module is 0 code when leaving the factory and controls the motor by default. Controller 0-5 channels can be controlled. When the controller selects channel 0-5, press the open or close button, all connected modules can act. If it is necessary to specify the channel to control the operation of the corresponding motor, it is necessary to code the point control module.
- For example, channel 1 is needed to control the louver motor. The specific operation steps are as follows.
- Power on the controller
- Connect the louver motor to the point control module (only one can be connected. If more than one is connected the channel can control all connected motors after the completion of the code)
- Press channel selection button to select a channel to 1.
- Press 0 button and stop button for more than 2 seconds at the same time. The forward rotation of the louver motor for 0.5 seconds indicates successful code matching.
- After successful code matching press the open, stop and close buttons and the motor should operate normally.
- If the motor steering is opposite to what is required press the close button and stop button mouth at step 4 for code alignment
- Tip if you need to control the light, turn the channel to L, and then press open button + stop button port for code alignment.
- When channel 0 is selected the code clearing operation is performed. After the code matching operation is completed the point controller restores the code 0 state

Using remote control:

- The controller is 0 code state when leaving the factory, different code remote control can control it. If you only need a remote control for its control can be code operation. After the coding is complete, others with different codes cannot control it. The code operation process is as follows:
- Power on the controller and put it in the standby state.
- Press both channels selection button at the same time and hold them for 2 seconds.
- Channel display displays c, then press any button of the remote control. Channel display returns the channel display.
- Check whether the code is normal. If not repeat steps 2 and 3
- Tip the button function on the remote control corresponds to the button on the controller panel, and the operation method is the same as that on the panel.
- Replace the battery of the remote control when the remote-control distance is close.

Important Note: This model is designed specifically for controlling LED lights. Please ensure that the channel is set to "L" before using it. For any additional functionality, it is necessary to purchase the appropriate accessories.







Light operation:

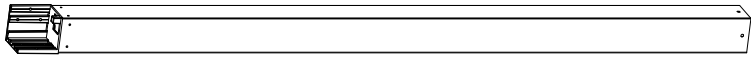
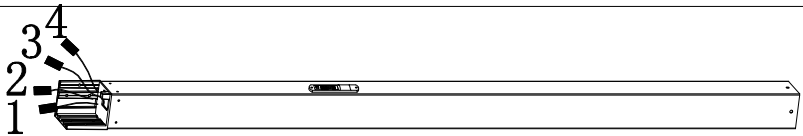
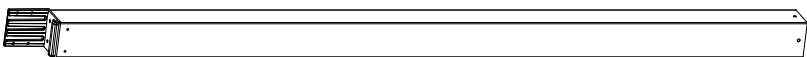
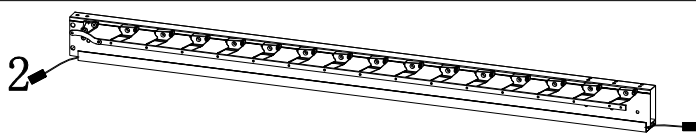
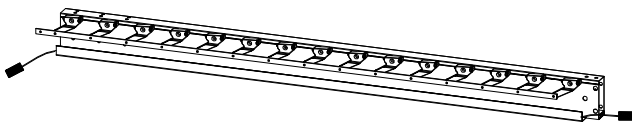
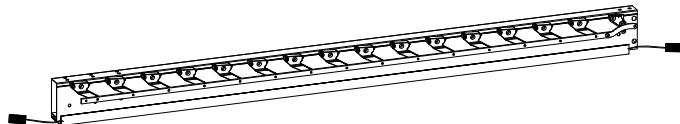
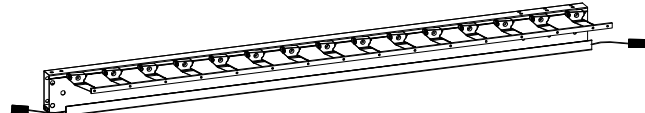
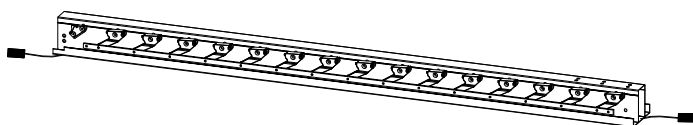
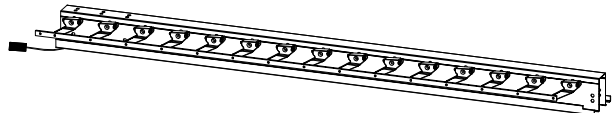
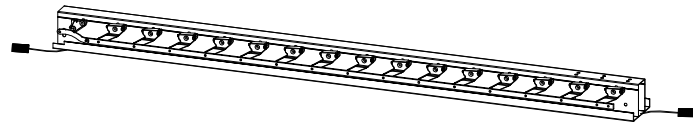
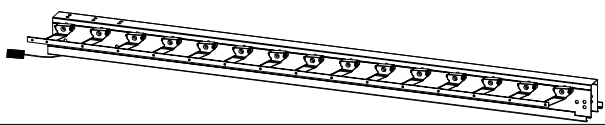
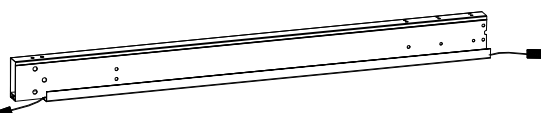
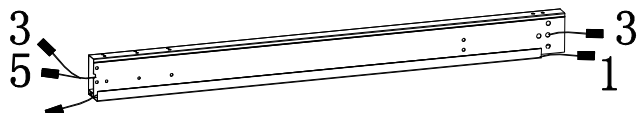
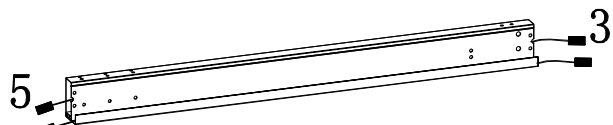

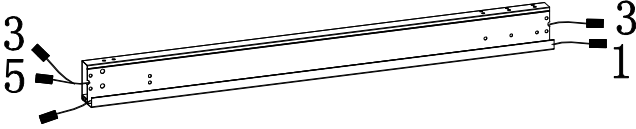
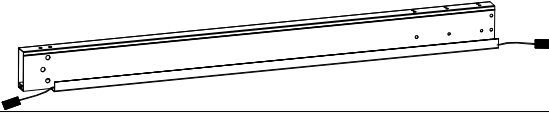
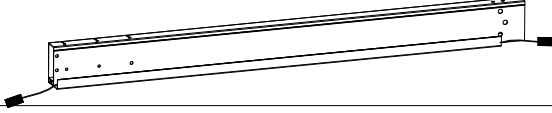
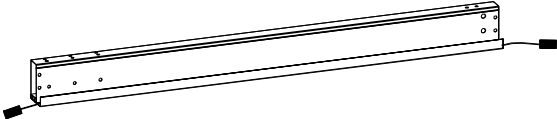
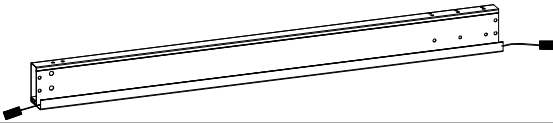

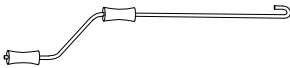
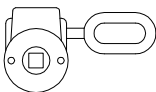
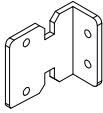

- The controller supports the multi-function light control, according to the matching light source and point control module, can adjust the light brightness, light color temperature light changes mode etc,
- Light switch button can only control the light on or off when adjusting the brightness or other function first select the channel to L and then through the operation button. The on button is used to adjust light brightness and off button is used to adjust light function such as color temperature switch change mode switch etc (this function may not be available according to the matching light source. Stop button port is to turn of the light.
- Tip the light has the function of timing off. When the continuous working time reaches about 6 hours the light will automatically turn off. When you need to continue the use, please turn it on again.



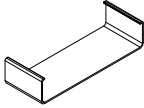
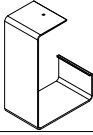

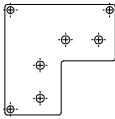

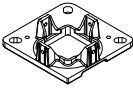

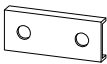
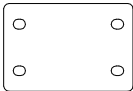
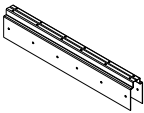
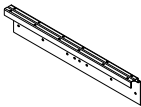
Parmeter	Content	Notes
Battery Type	Lithium Ion	
Battery Specifications	11. 1v 9 Ah 100Wh	
Charge Time	External Source 5.5h Solar 6h	When maximum power is reached
Remote Control Distance	20 meters	
Environment Temperature	-5 to 40 degrees Celsius	
Weight		

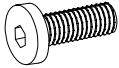
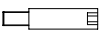
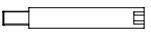

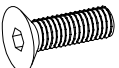
Important Note: This model is designed specifically for controlling LED lights. Please ensure that the channel is set to "L" before using it. For any additional functionality, it is necessary to purchase the appropriate accessories.

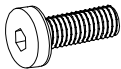
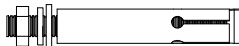
A		3
A1		1
A2		2
B		1
B1		1
C		1
C1		1
D		2
D1		2
D2		1
D3		1
E		1
E1		1
E2		1

E3		1
F		1
F1		1
F2		1
F3		1
G		3
G1		1
H		120
I1		4
J		2
K		4
K1		4
L		3
L1		6

L2		3
L3		6
M		12
N		6
N1		4
N2		2
O		6
O1		6
P		8
P1		2
Q		3
Q1		6

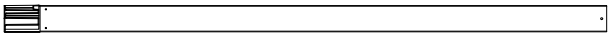
1#	 M6*15	96+5
2#	 M8*55	30
3#	 M8*70	2
4#	 M4*12	8
5#	 M6*15	28
6#	 M6	8
7#	 M6*40	4
8#	 M6*10	196+5
9#	 M8	18
	 6mm	1
	 4mm	1
	 4mm	1
		1

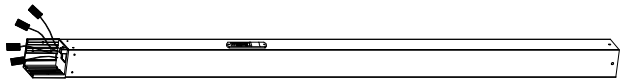
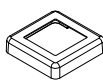
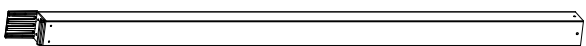
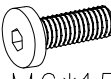
	<p>A X3</p>  <p>0 X6</p>
	<p>A1 X1</p>  <p>01 X6</p>
	<p>A2 X2</p>  <p>M6*15</p> <p>1# X24</p>

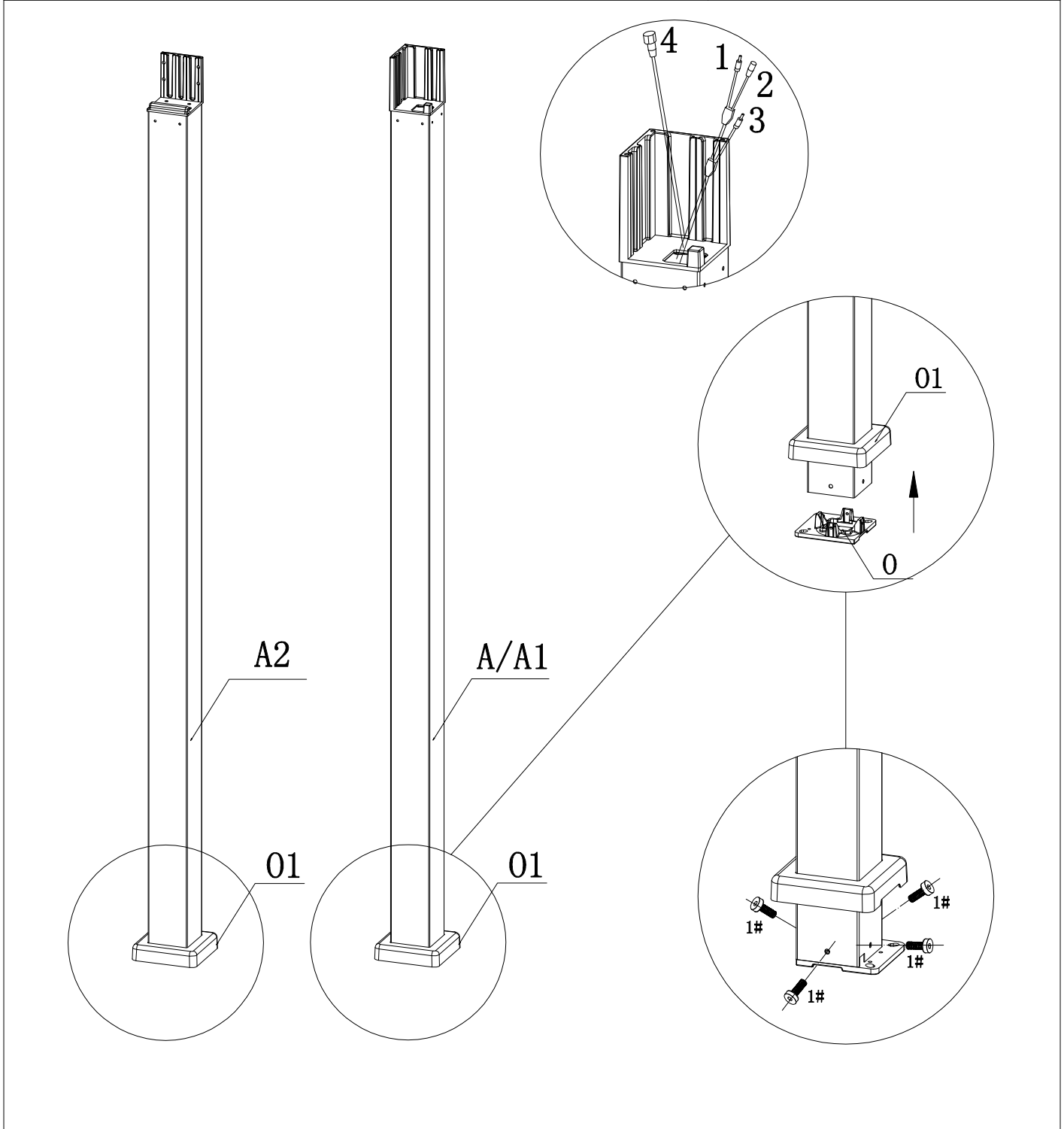

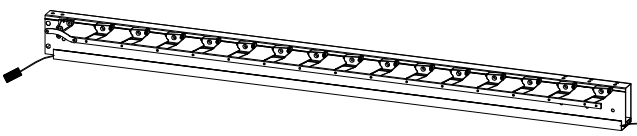
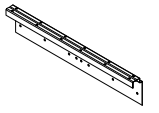
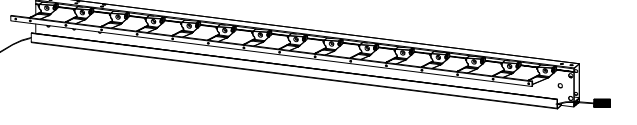
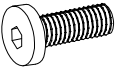

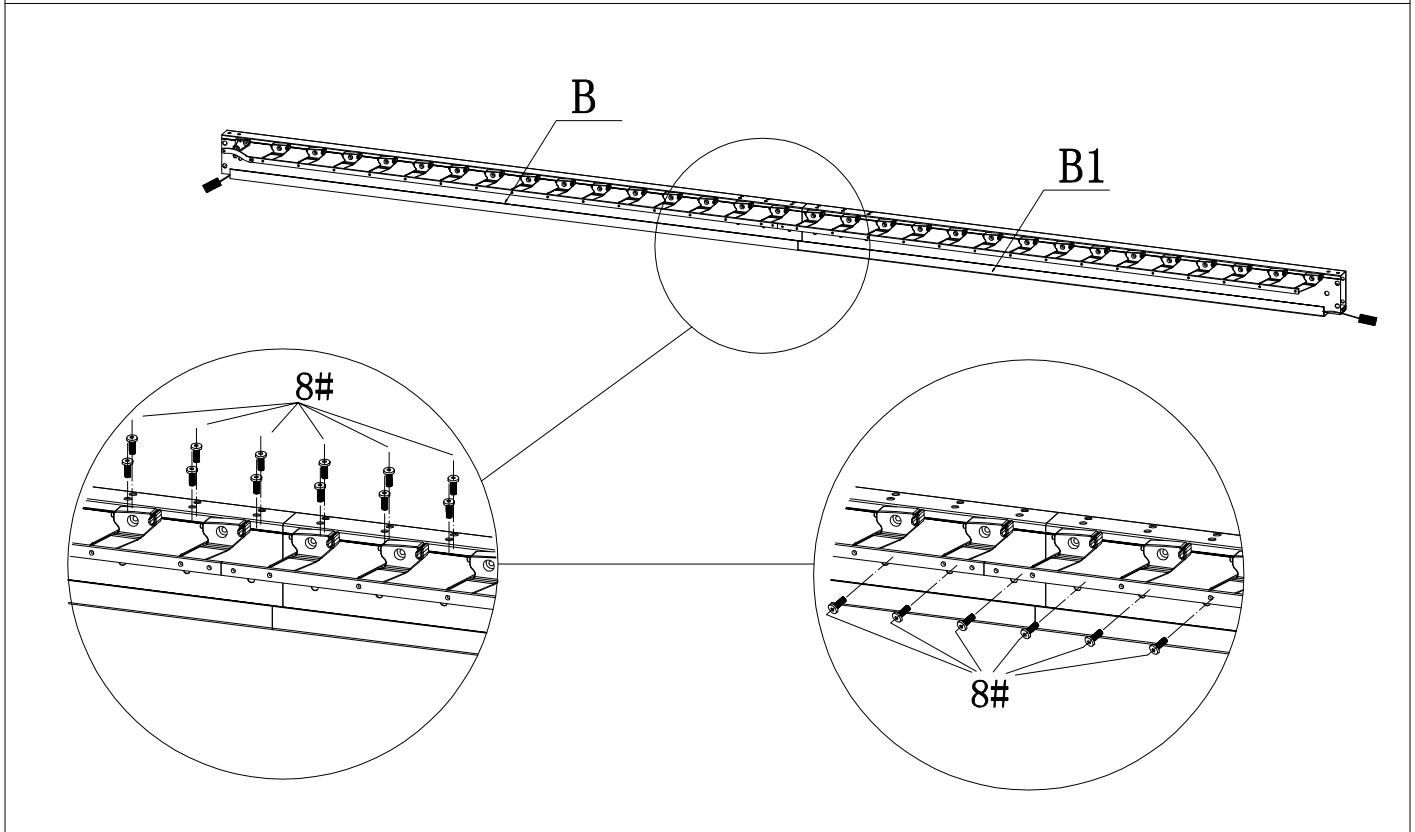
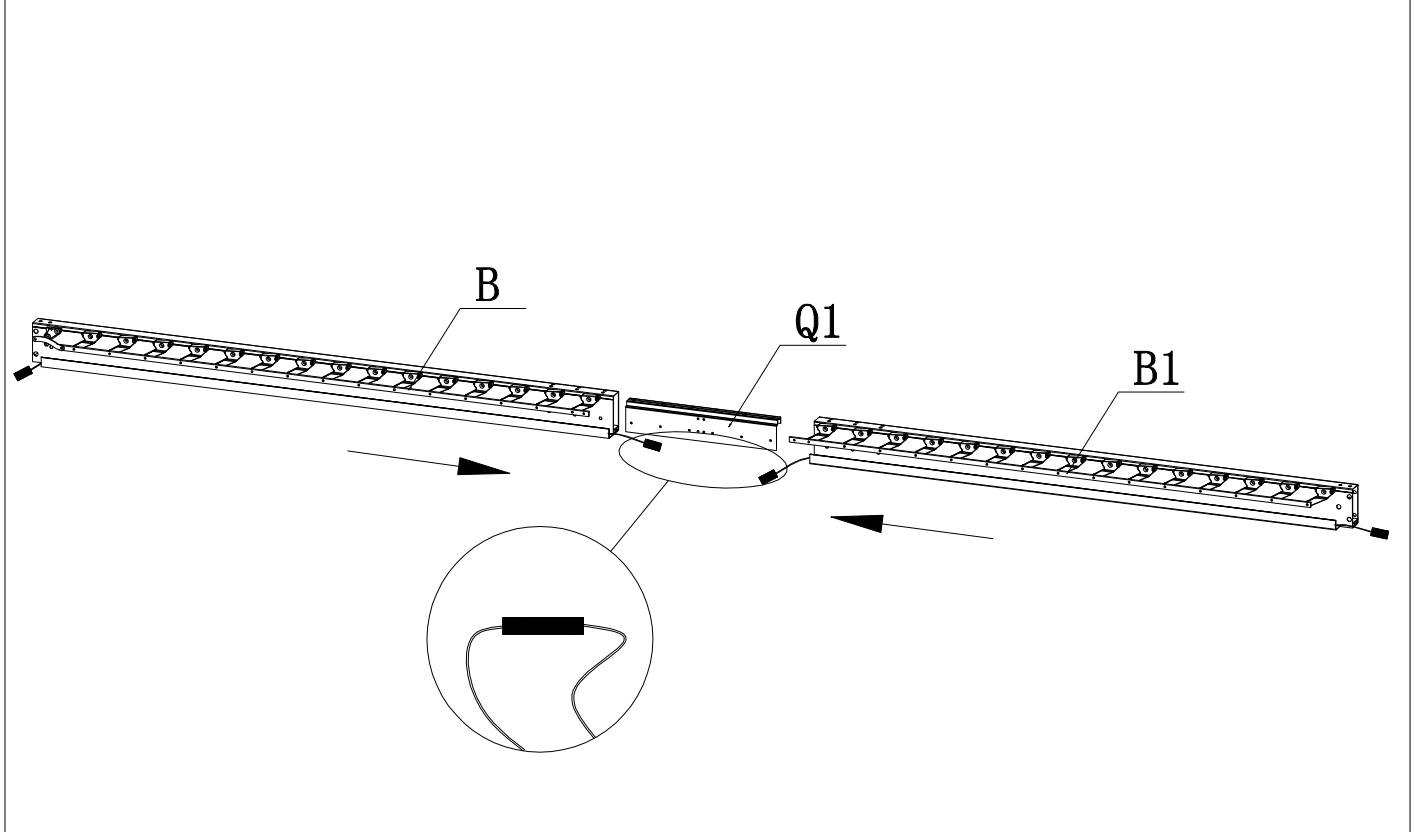

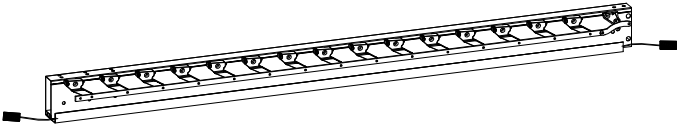
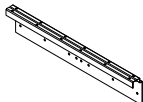
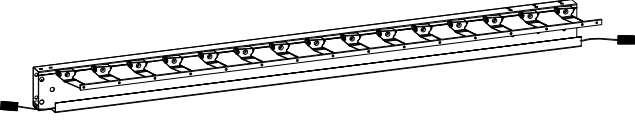
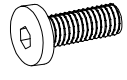

C X1

Q1 X1

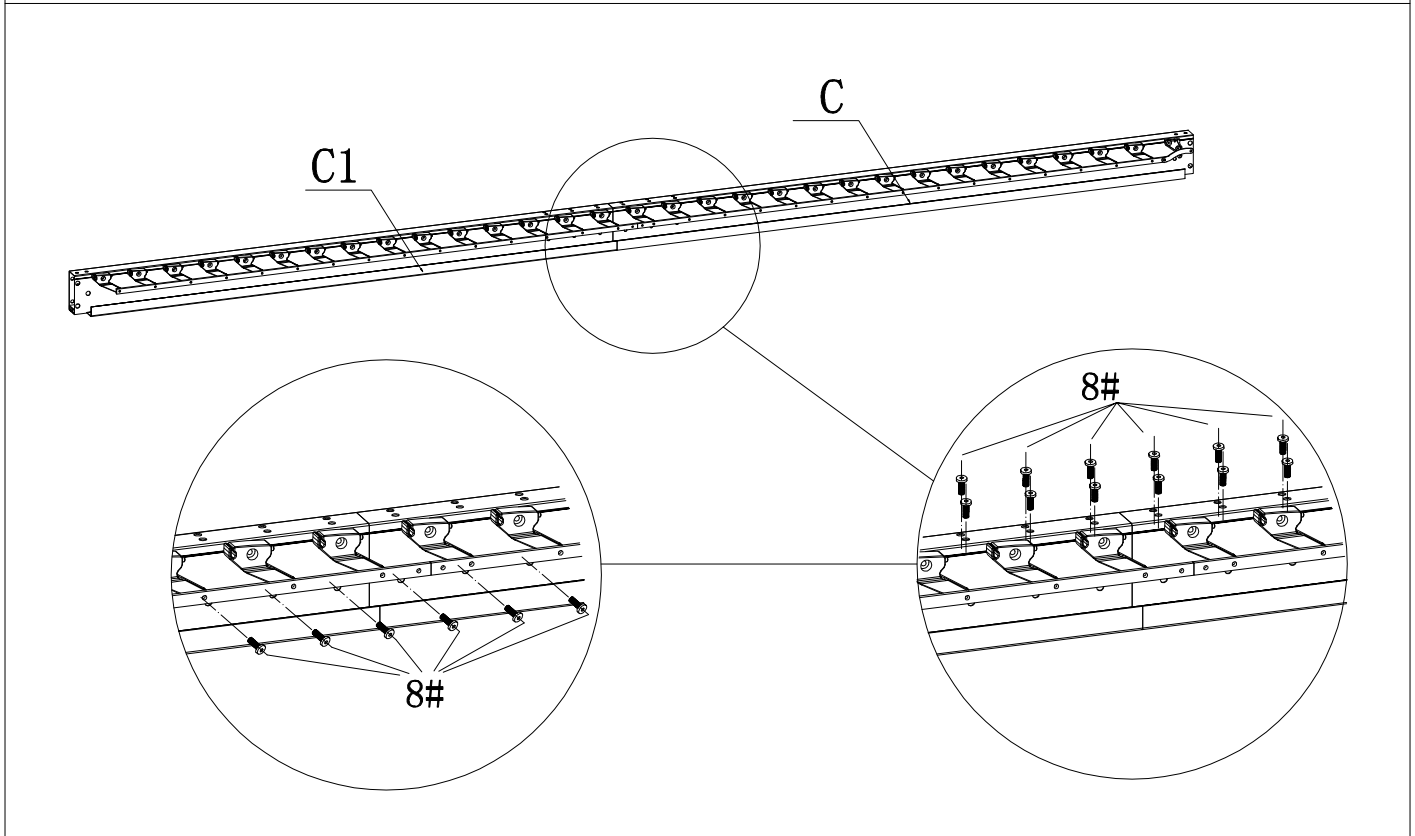
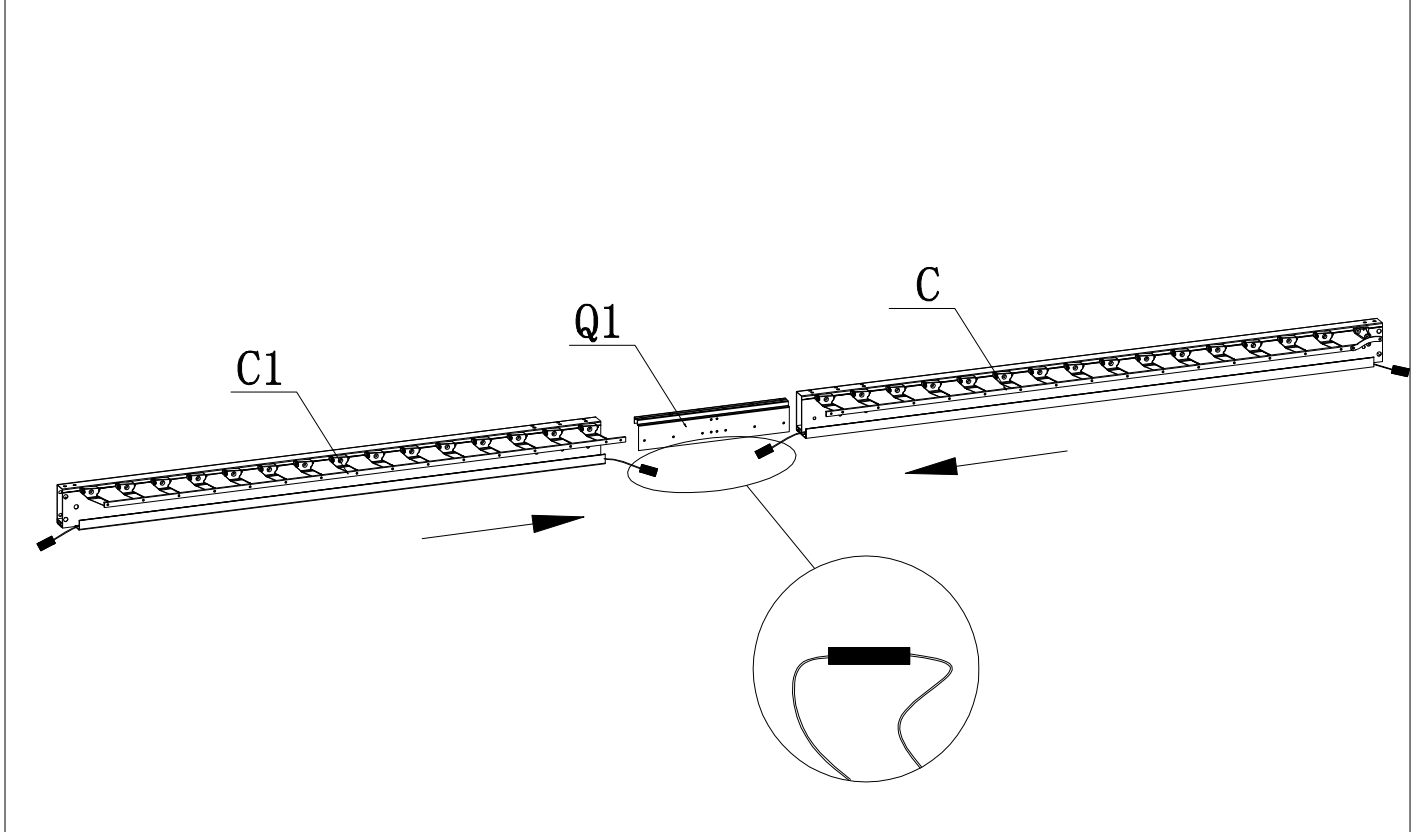

C1 X1

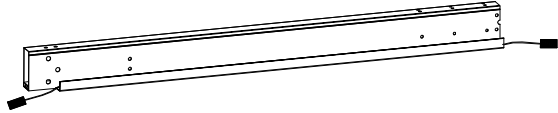
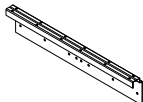
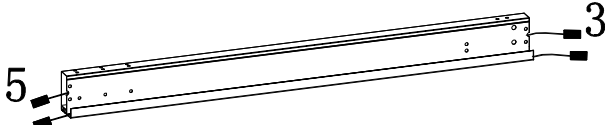
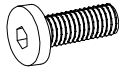
8# X18

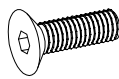

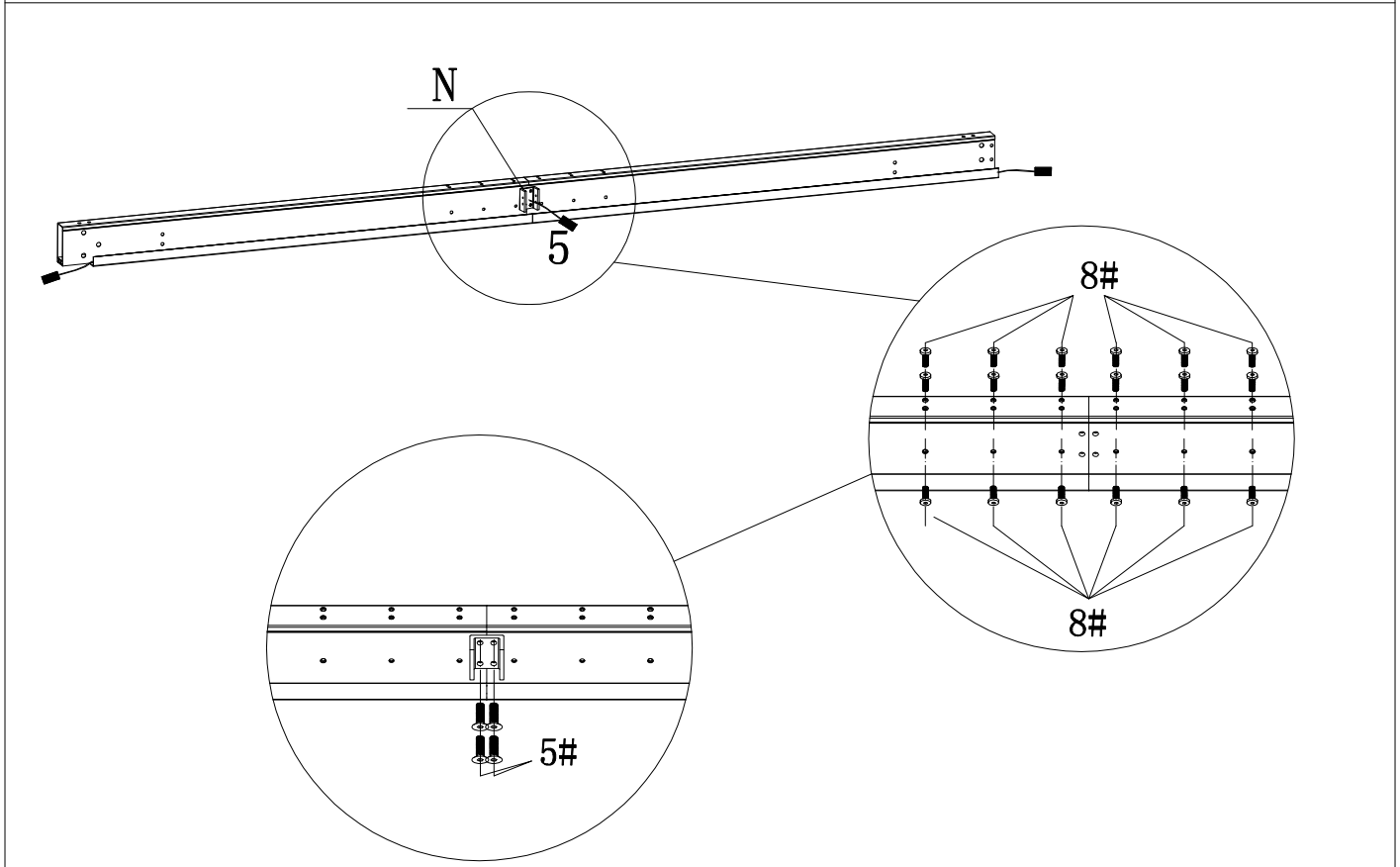
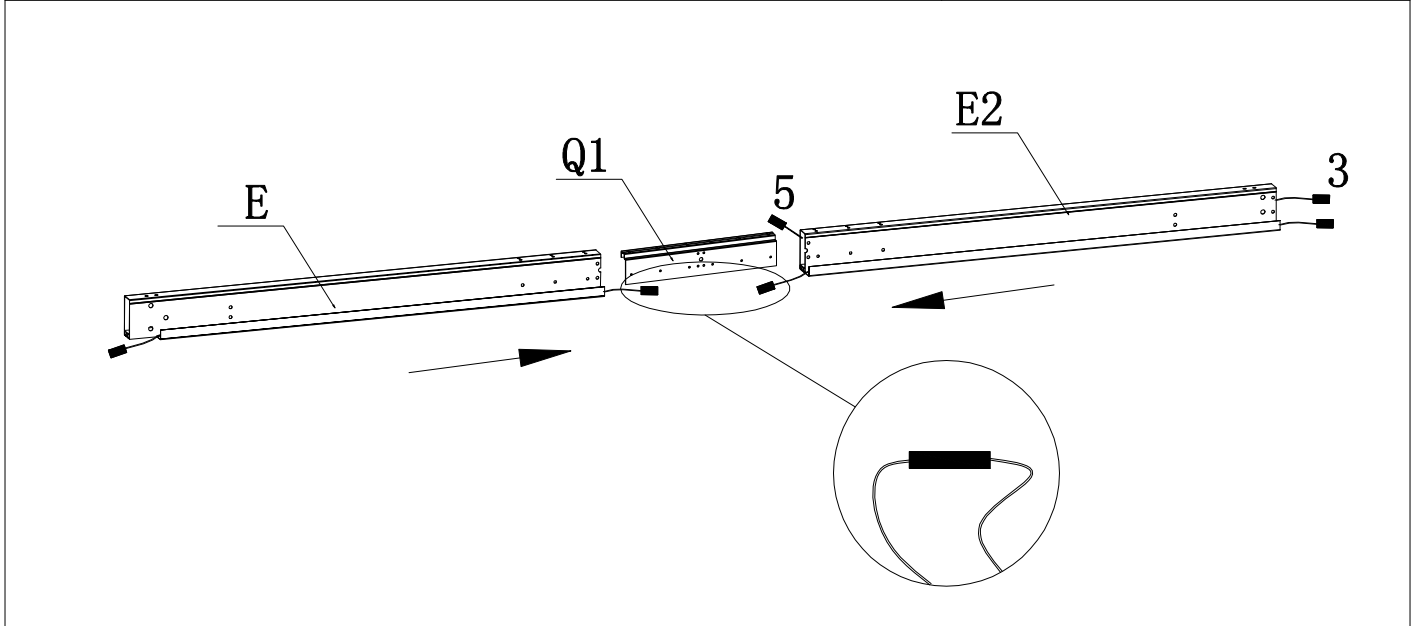

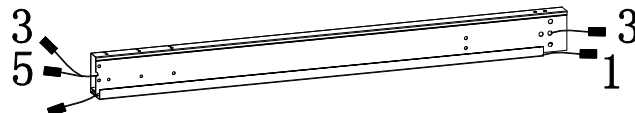
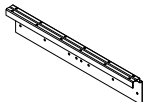
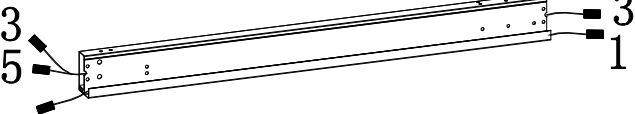
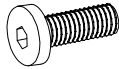

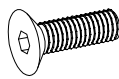

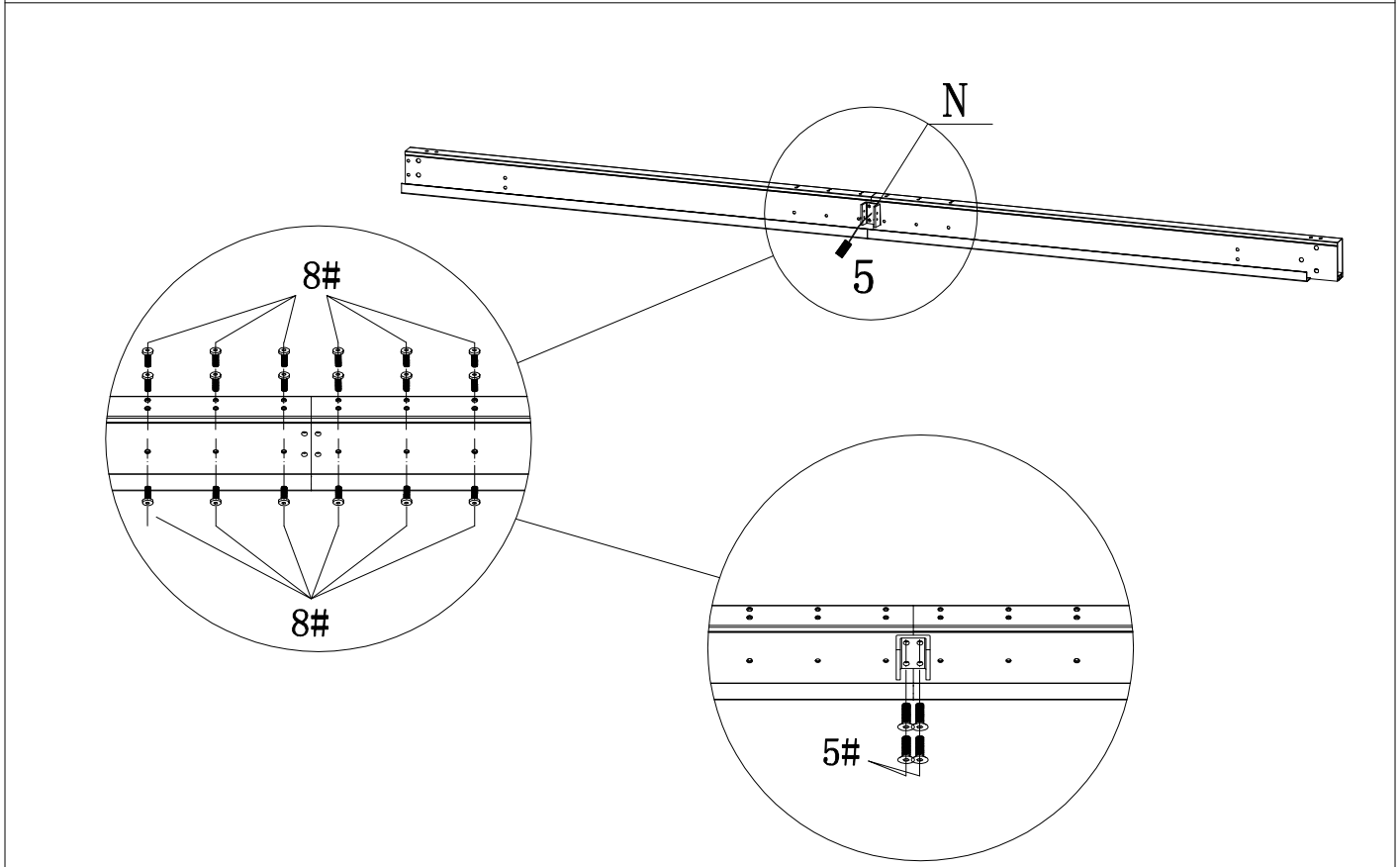
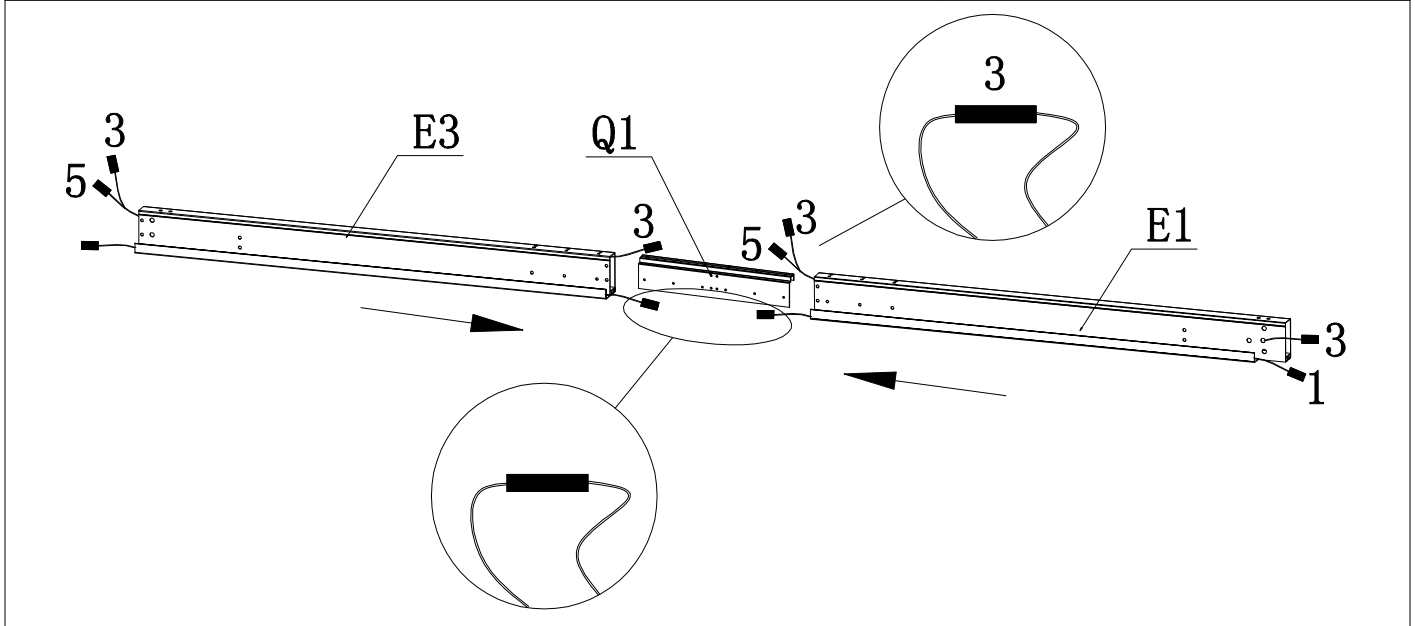

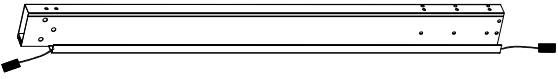
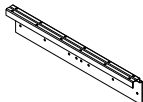
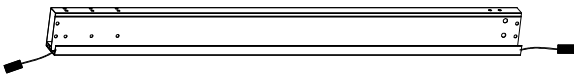
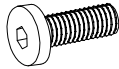
 <p>E1 X1</p>	 <p>Q1 X1</p>
 <p>E3 X1</p>	 <p>8# X18</p>
 <p>N X1</p>	 <p>5# X4</p>

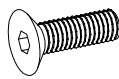

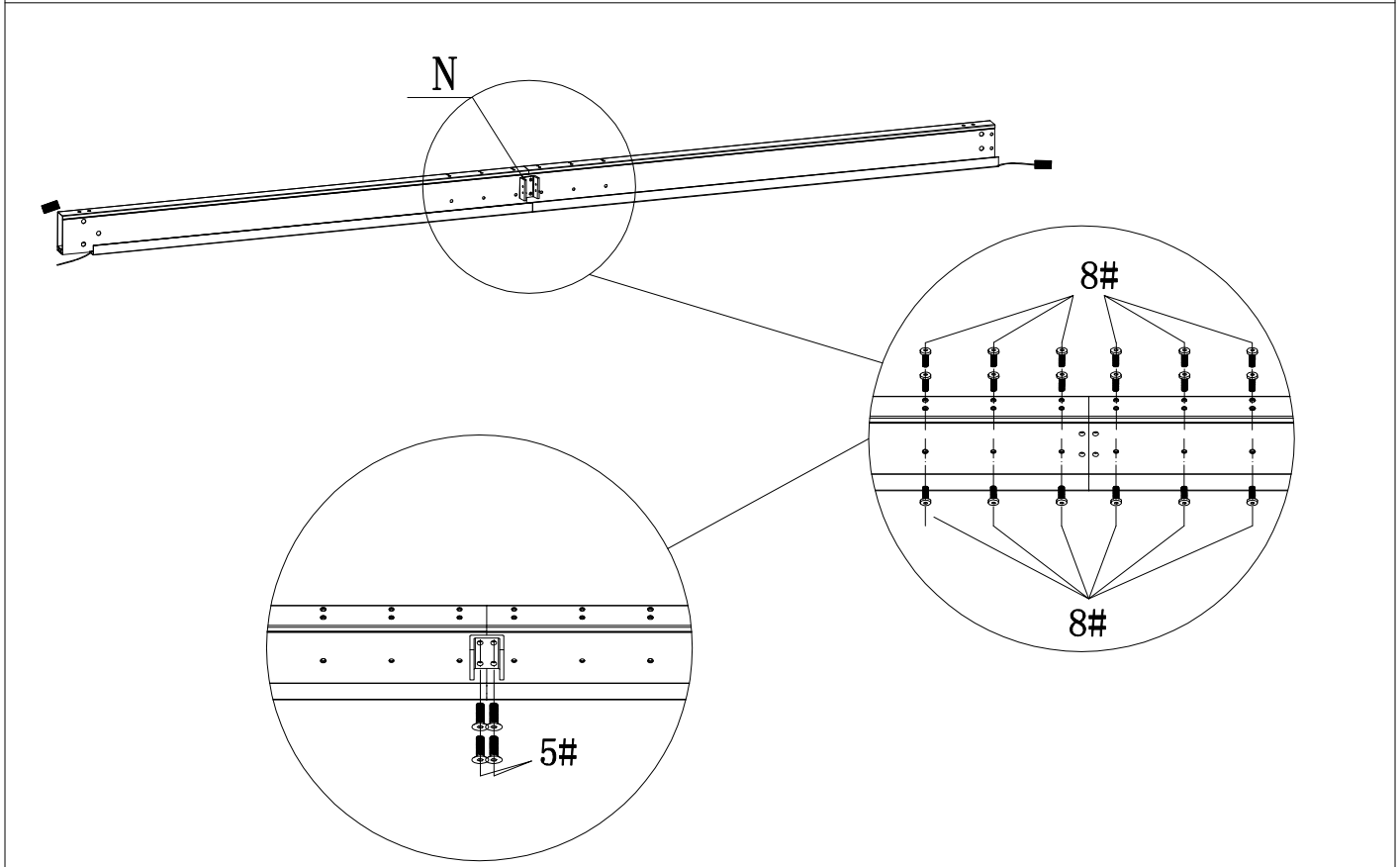
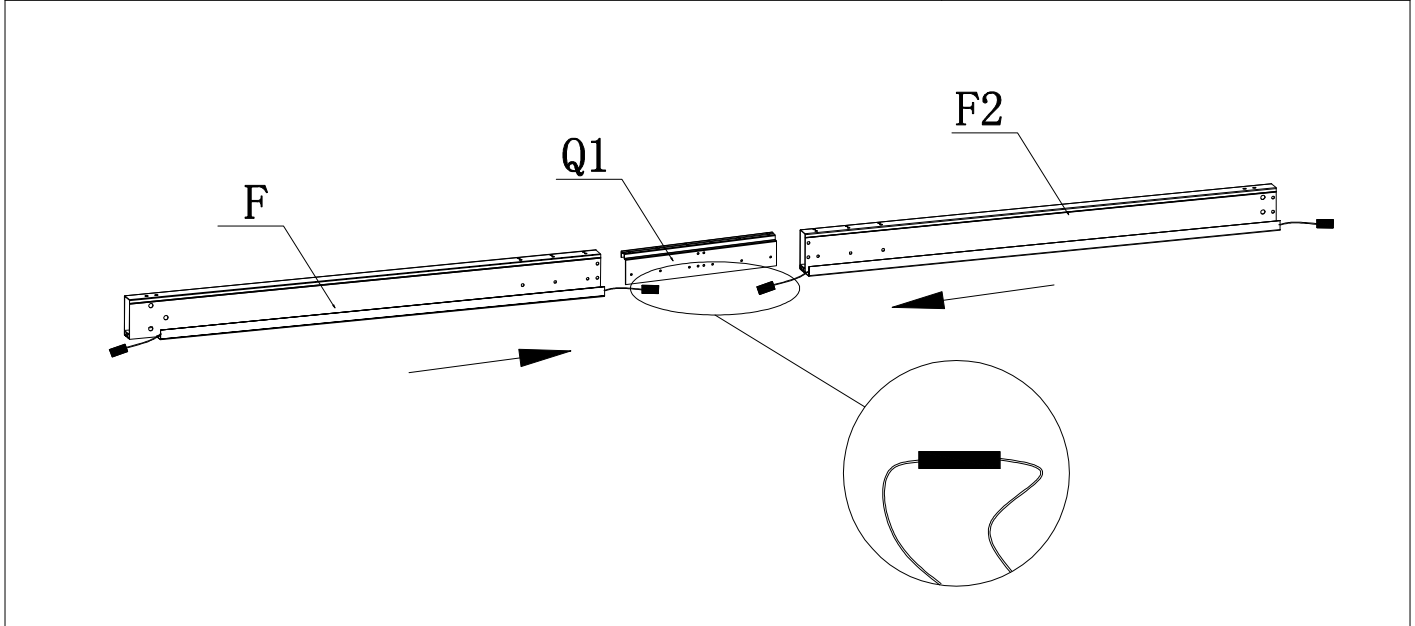

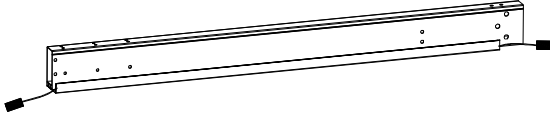
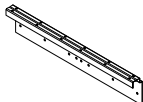
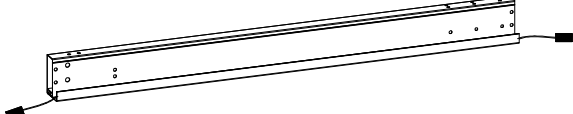
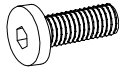

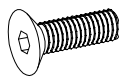

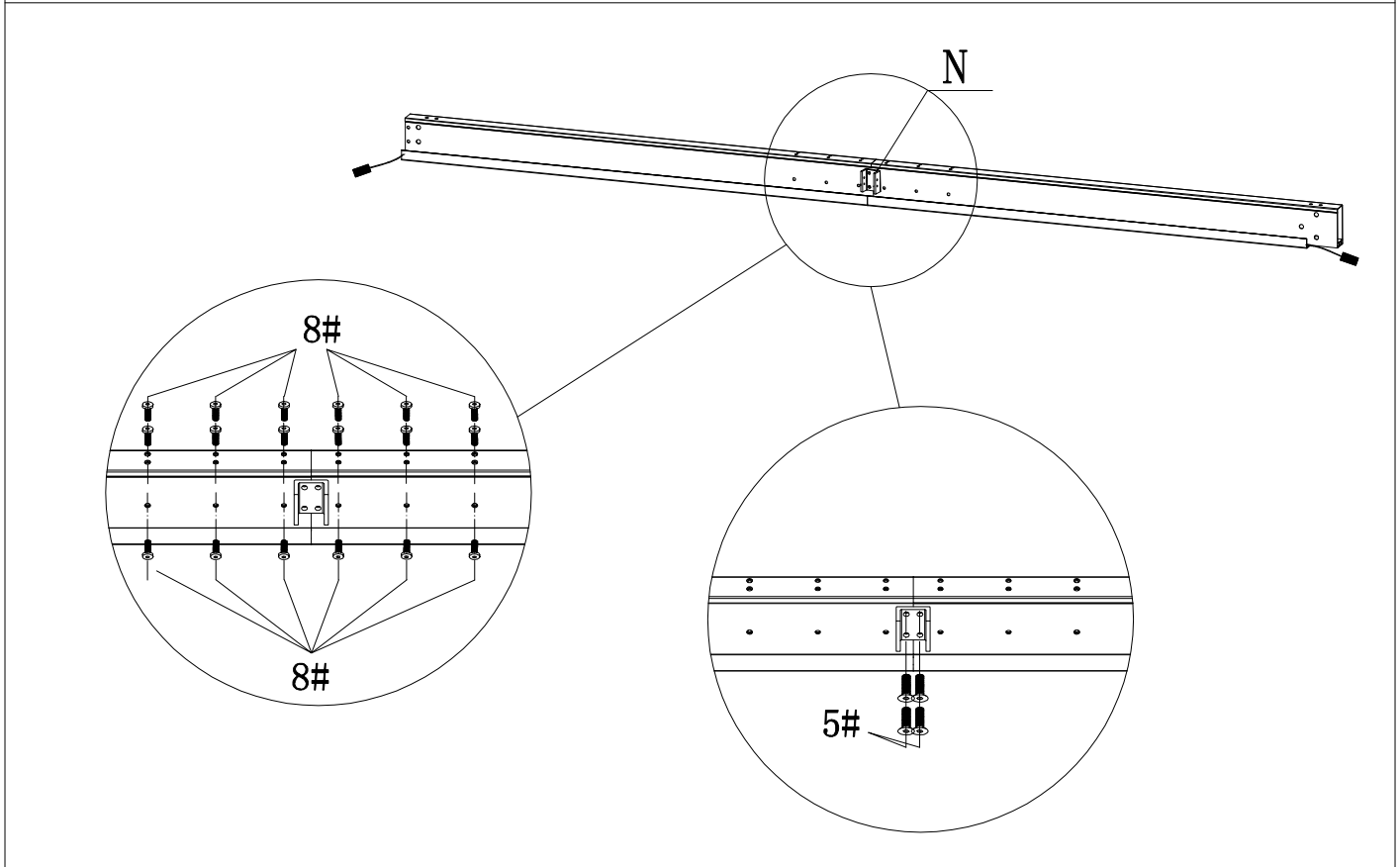
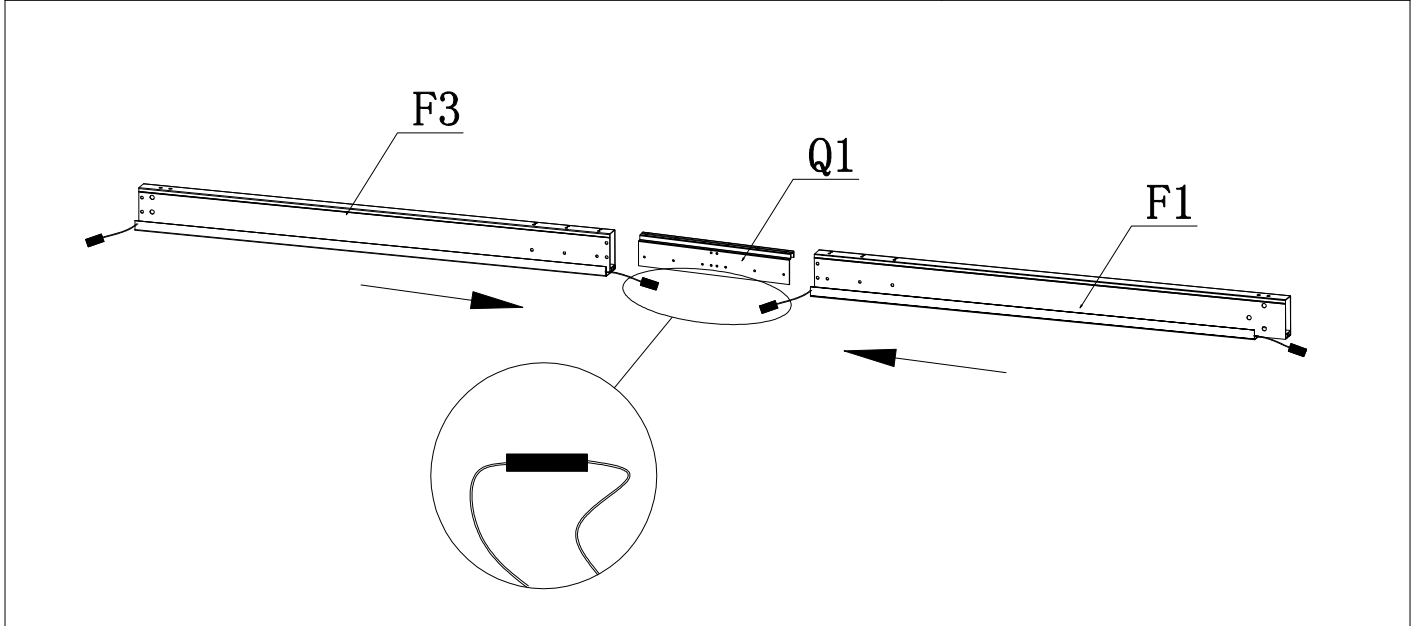
 <p>D X2</p>	 <p>Q X2</p>
 <p>D1 X2</p>	 <p>8#X48</p>

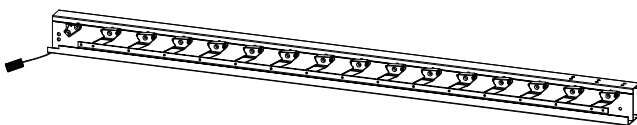
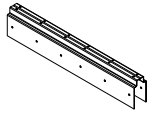
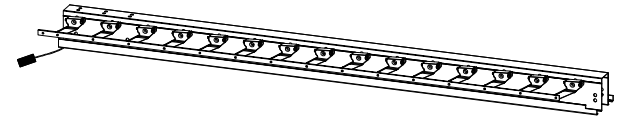
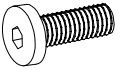

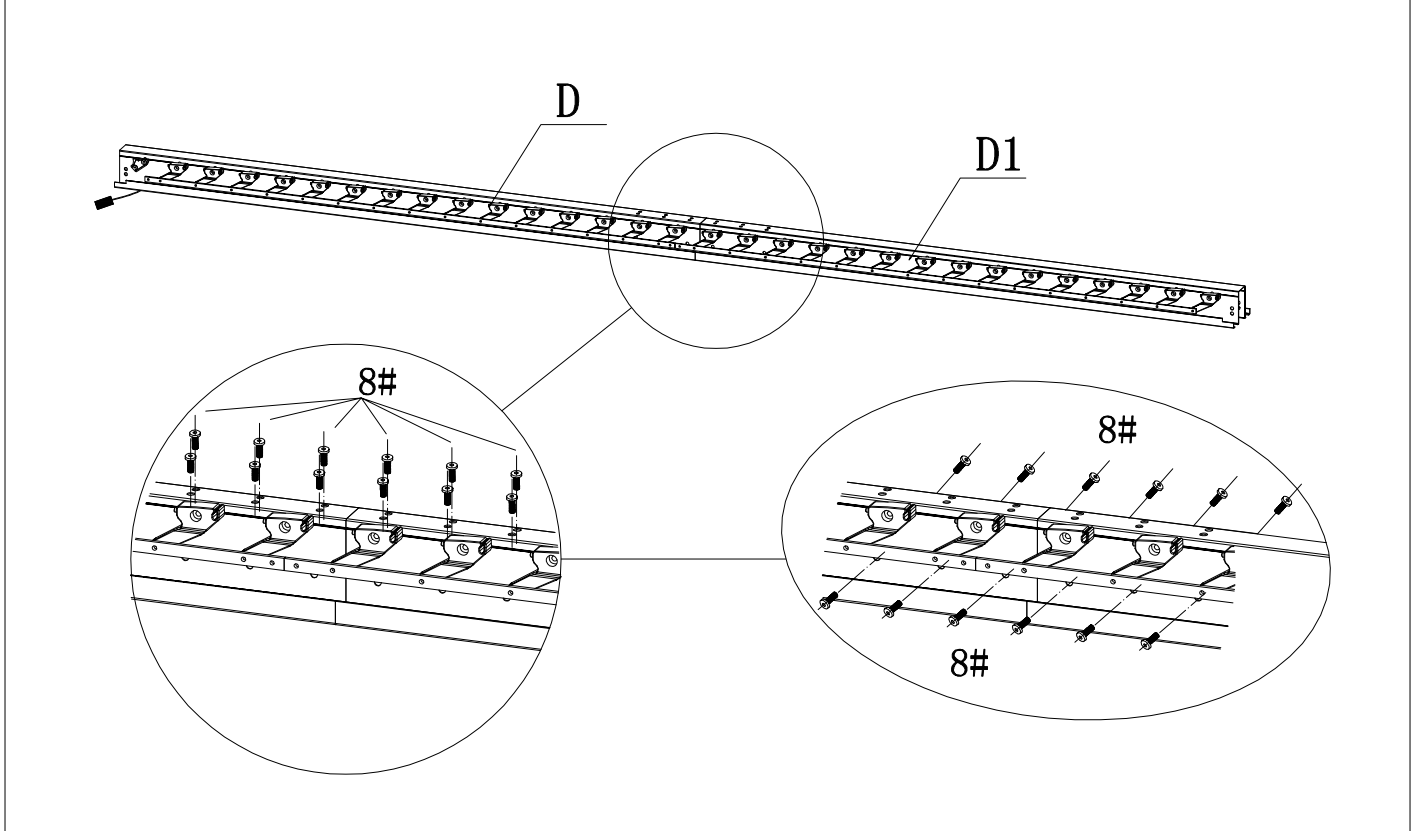
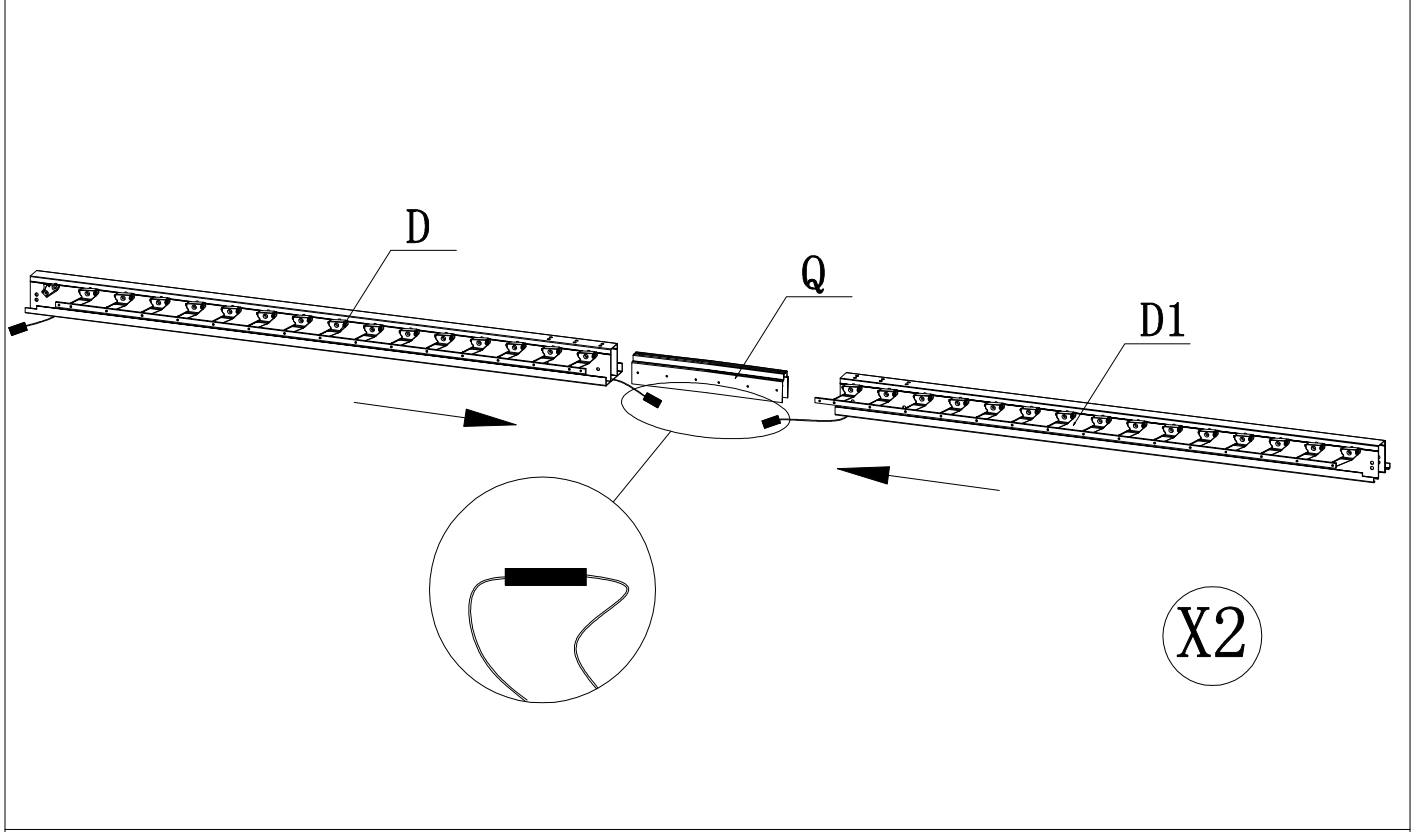

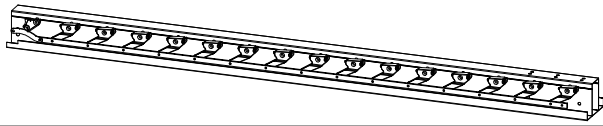
D2 X1

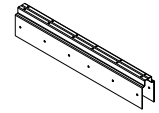

Q X1

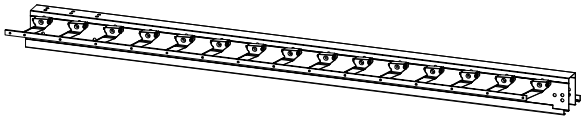

D3 X1

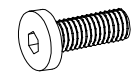

8# X24

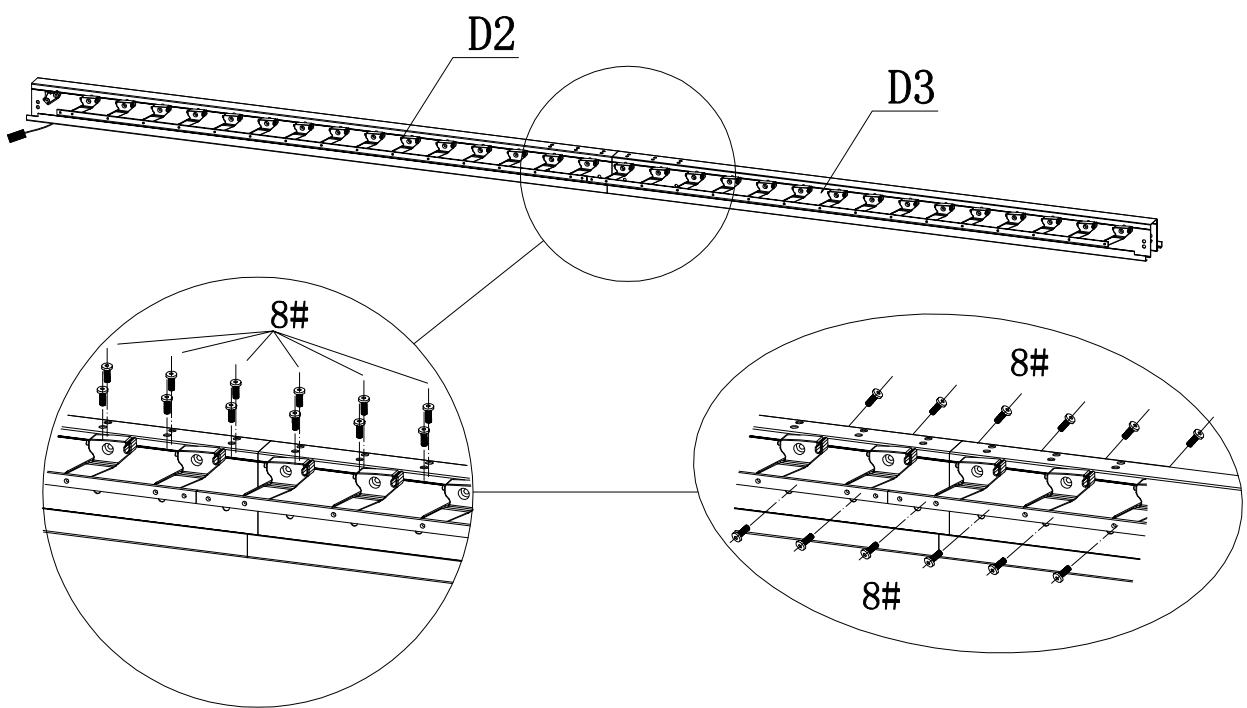
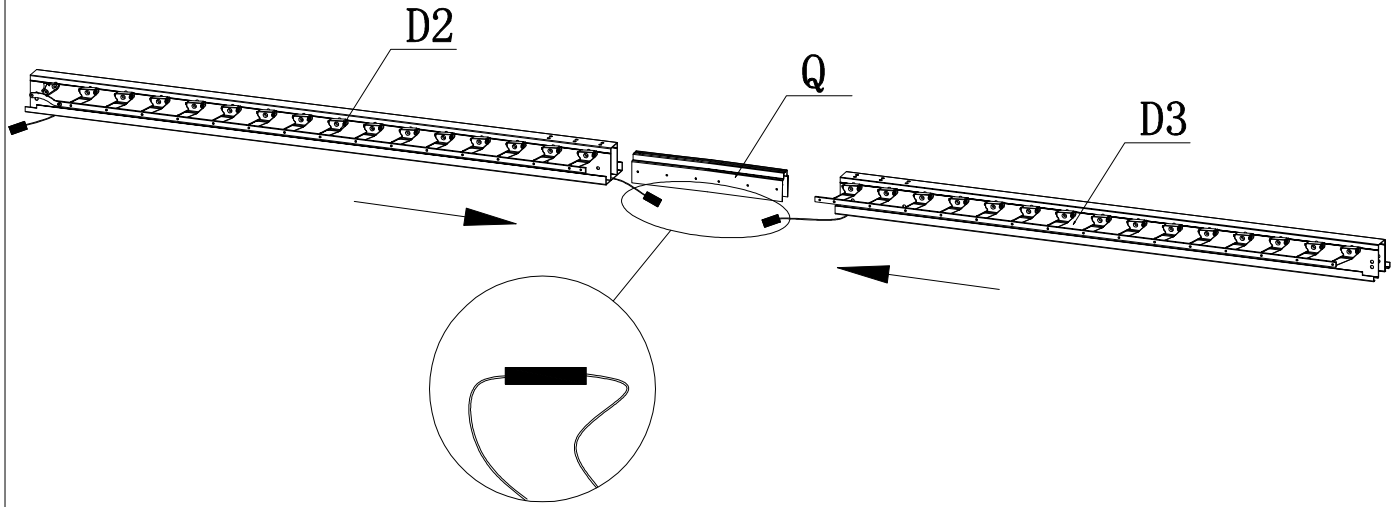

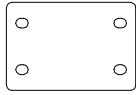

P1 X2

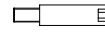

2# X8

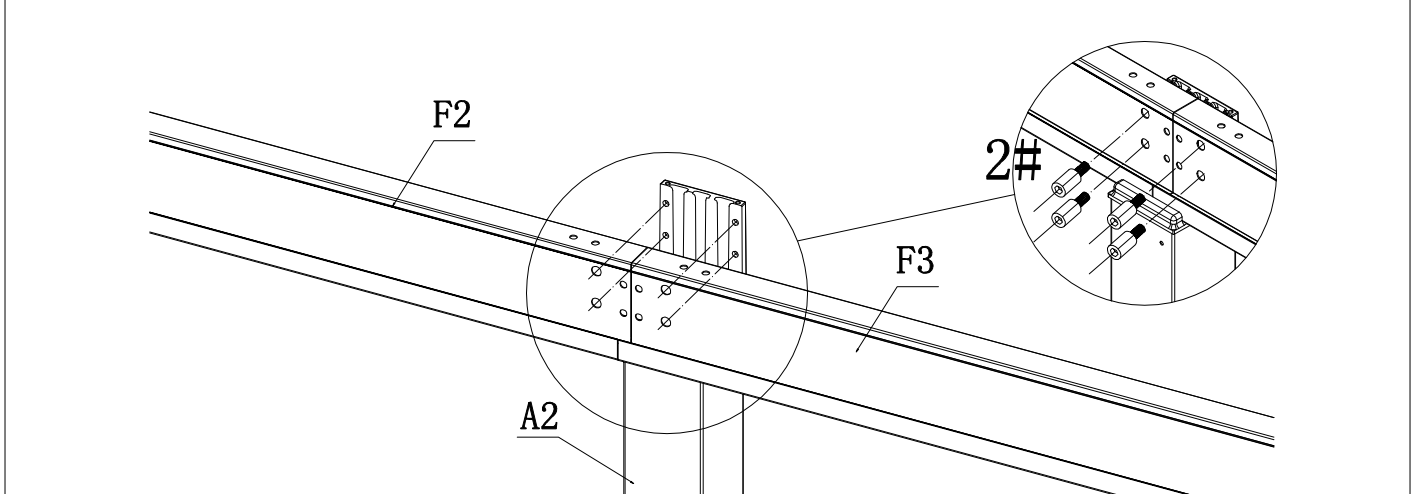
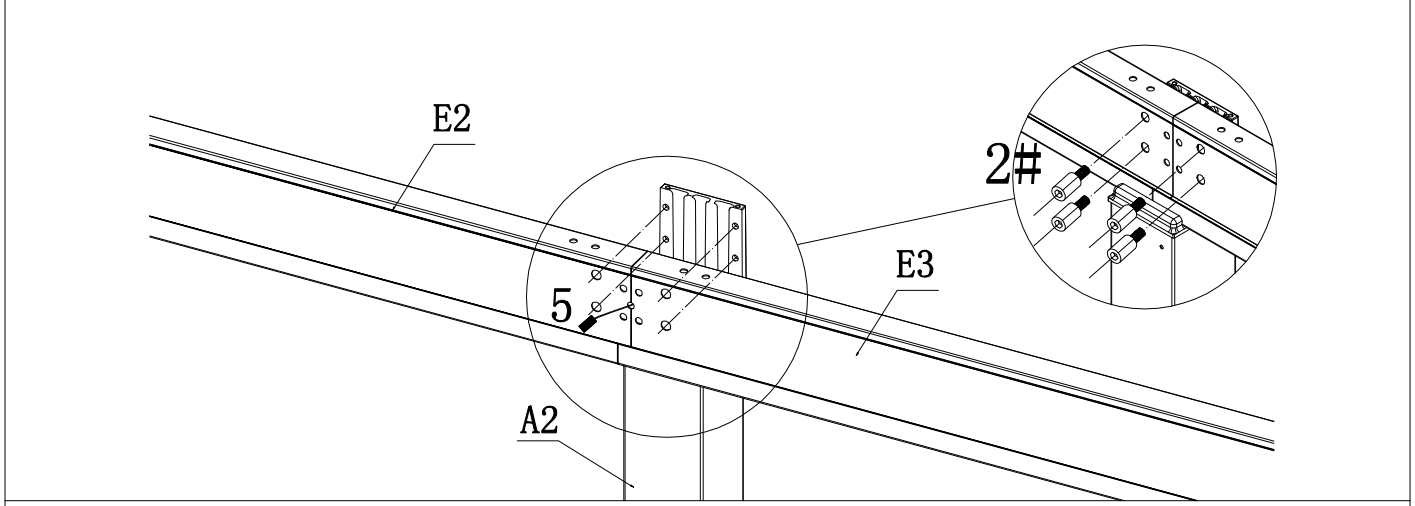
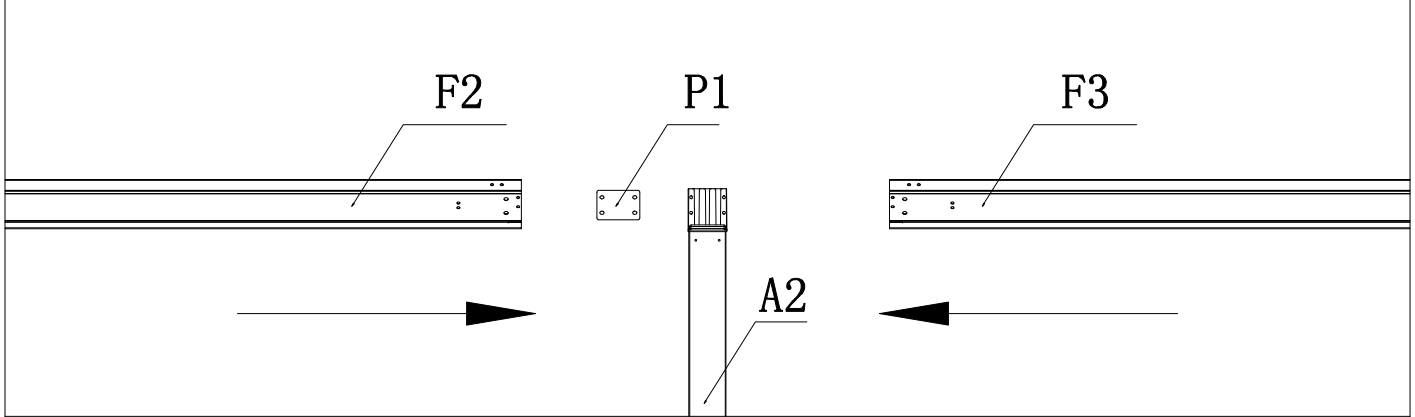
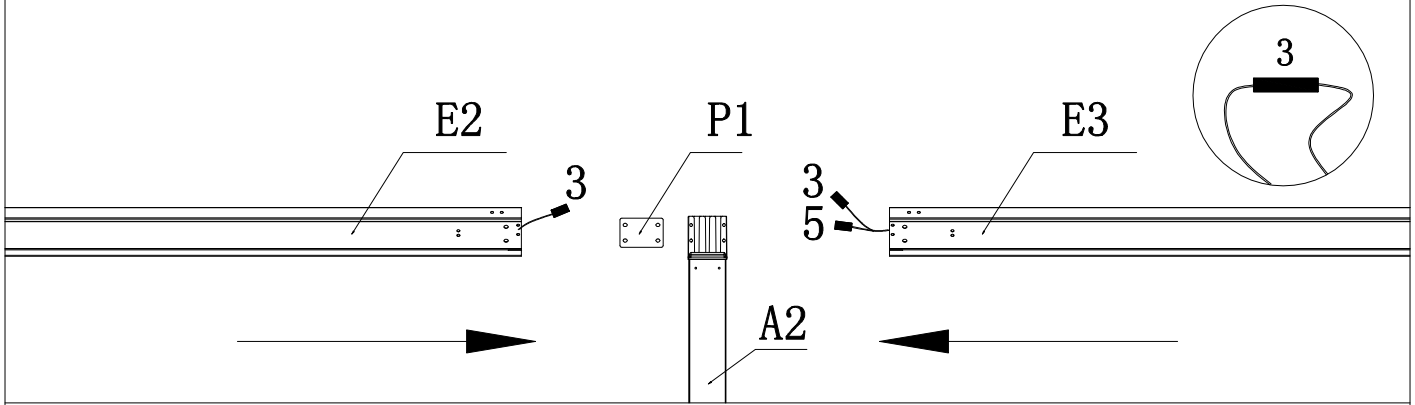



M8*55

2# X12

①

2#

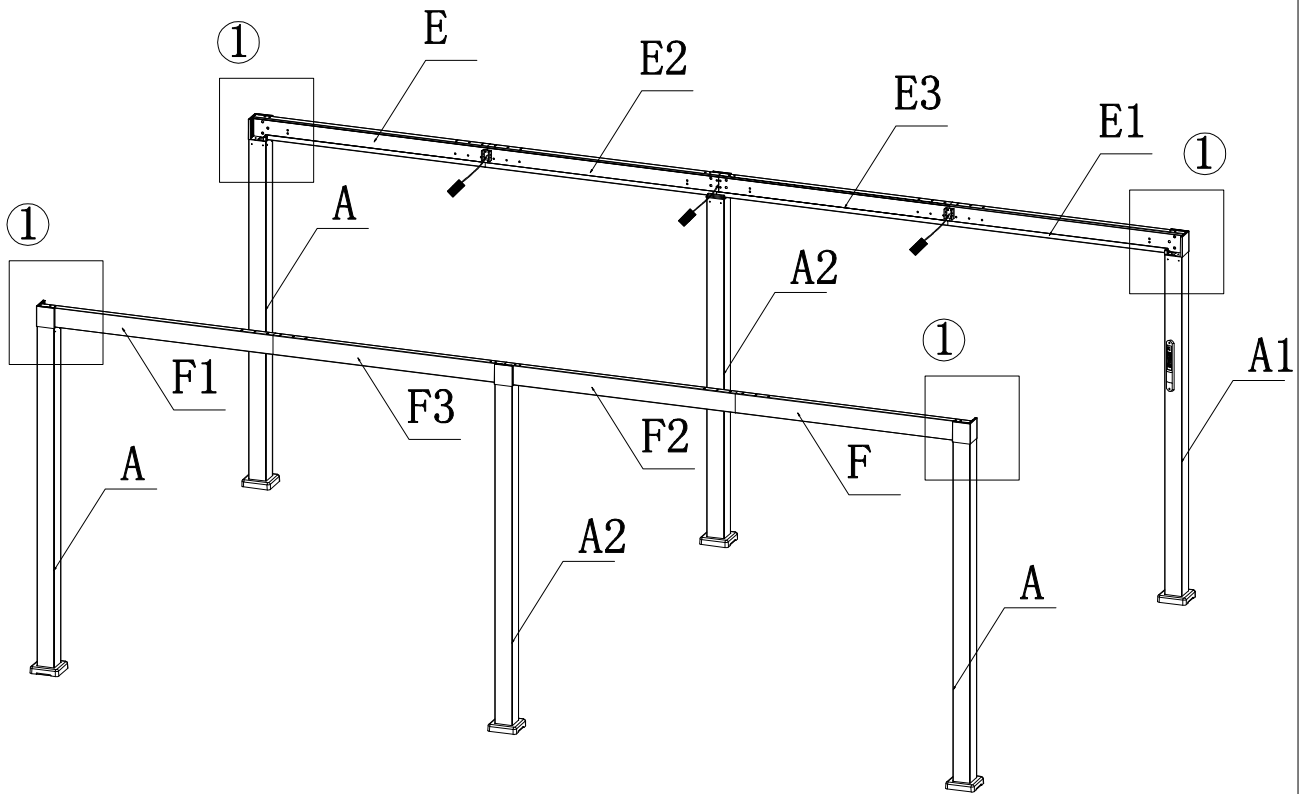
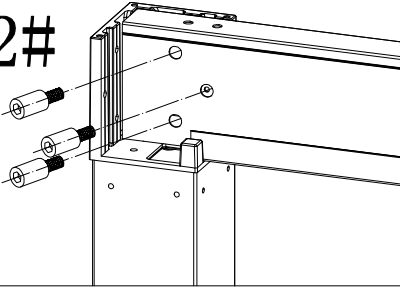



M8*55

2# X10



M8*70

3# X2

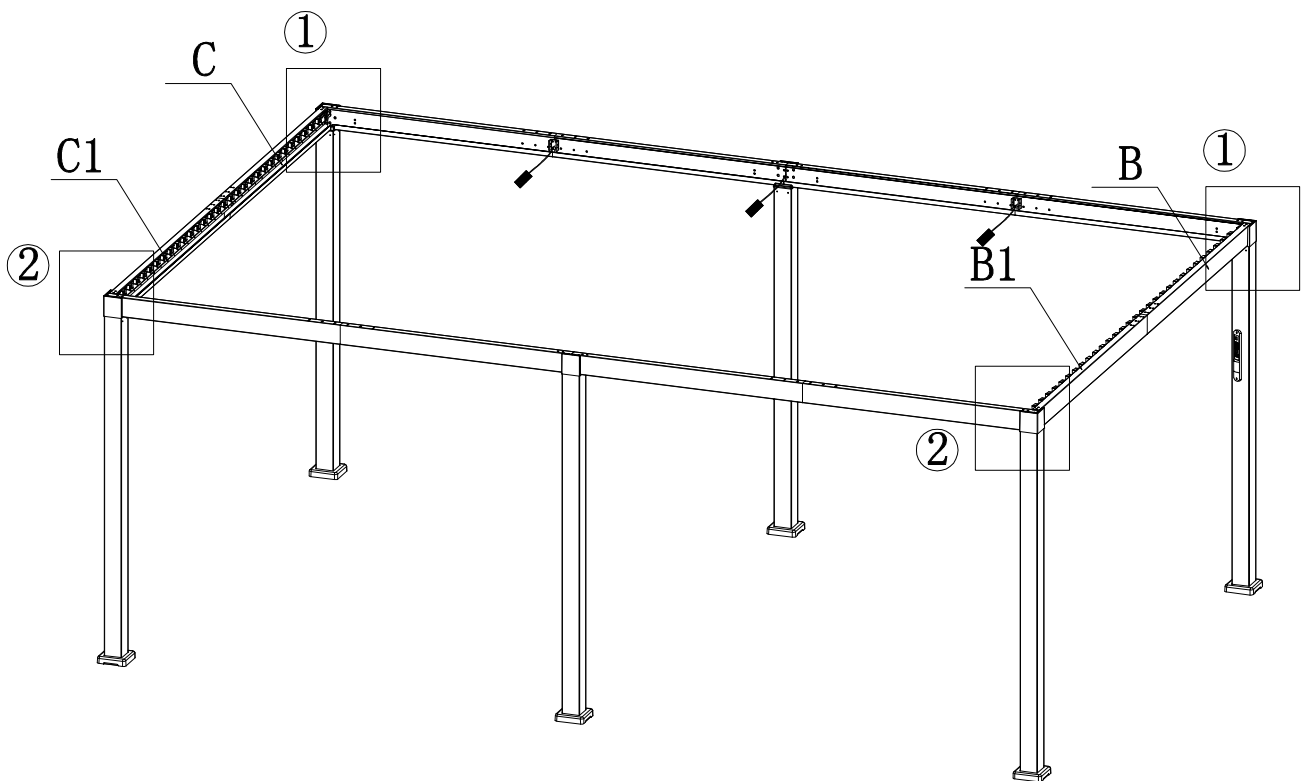
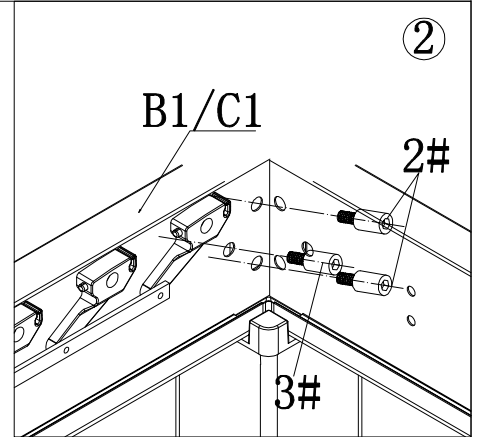
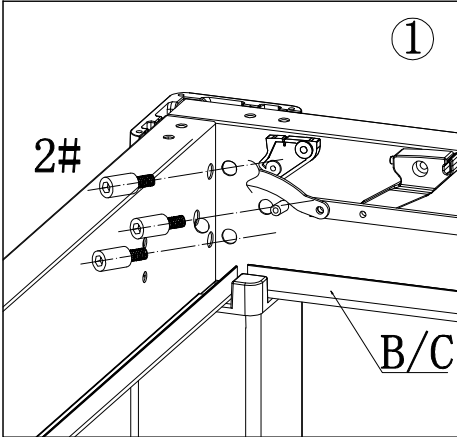



N X2

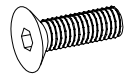

M6*15

5# X8

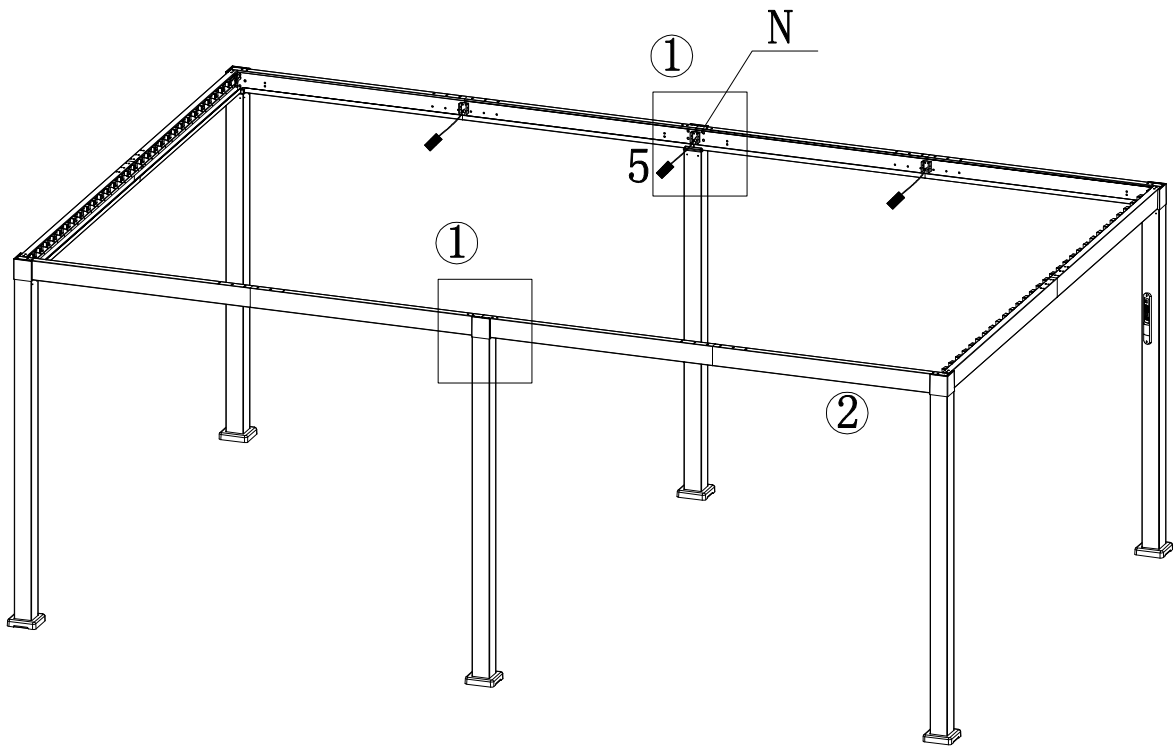
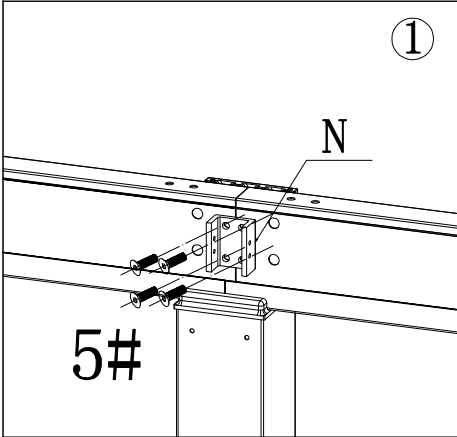

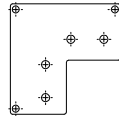

N1 X4



N2 X2

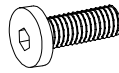

1# X40

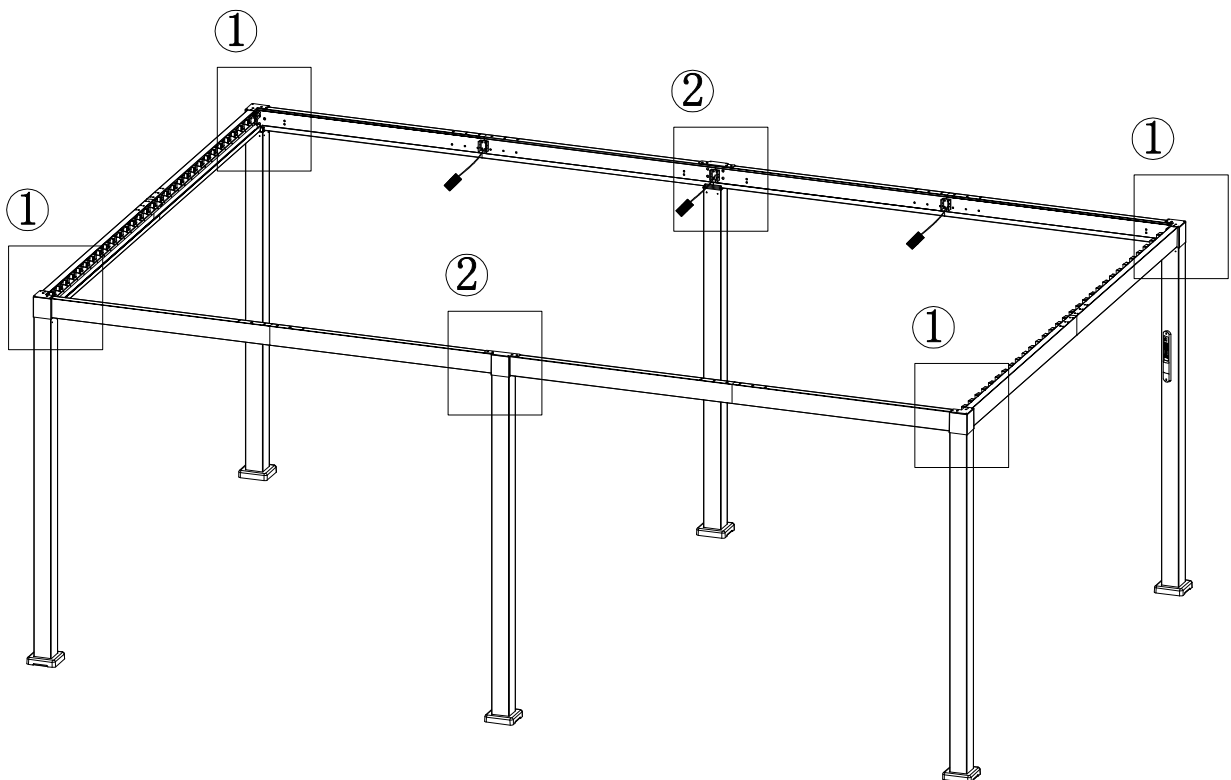
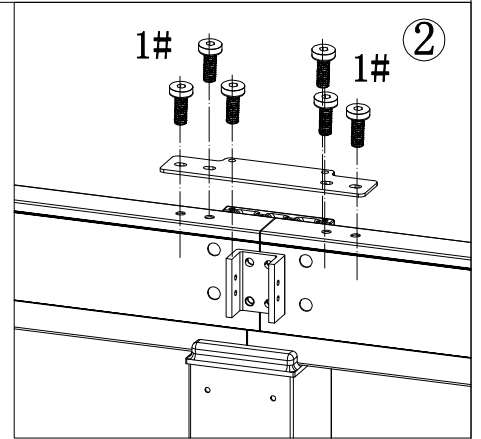
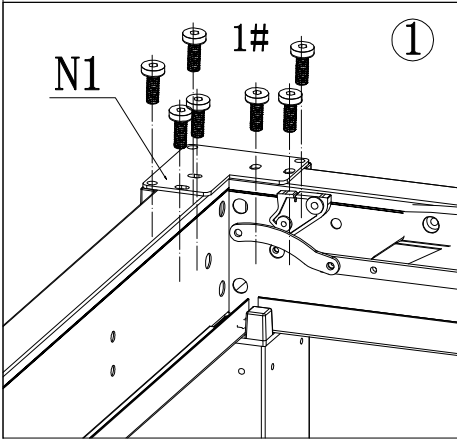

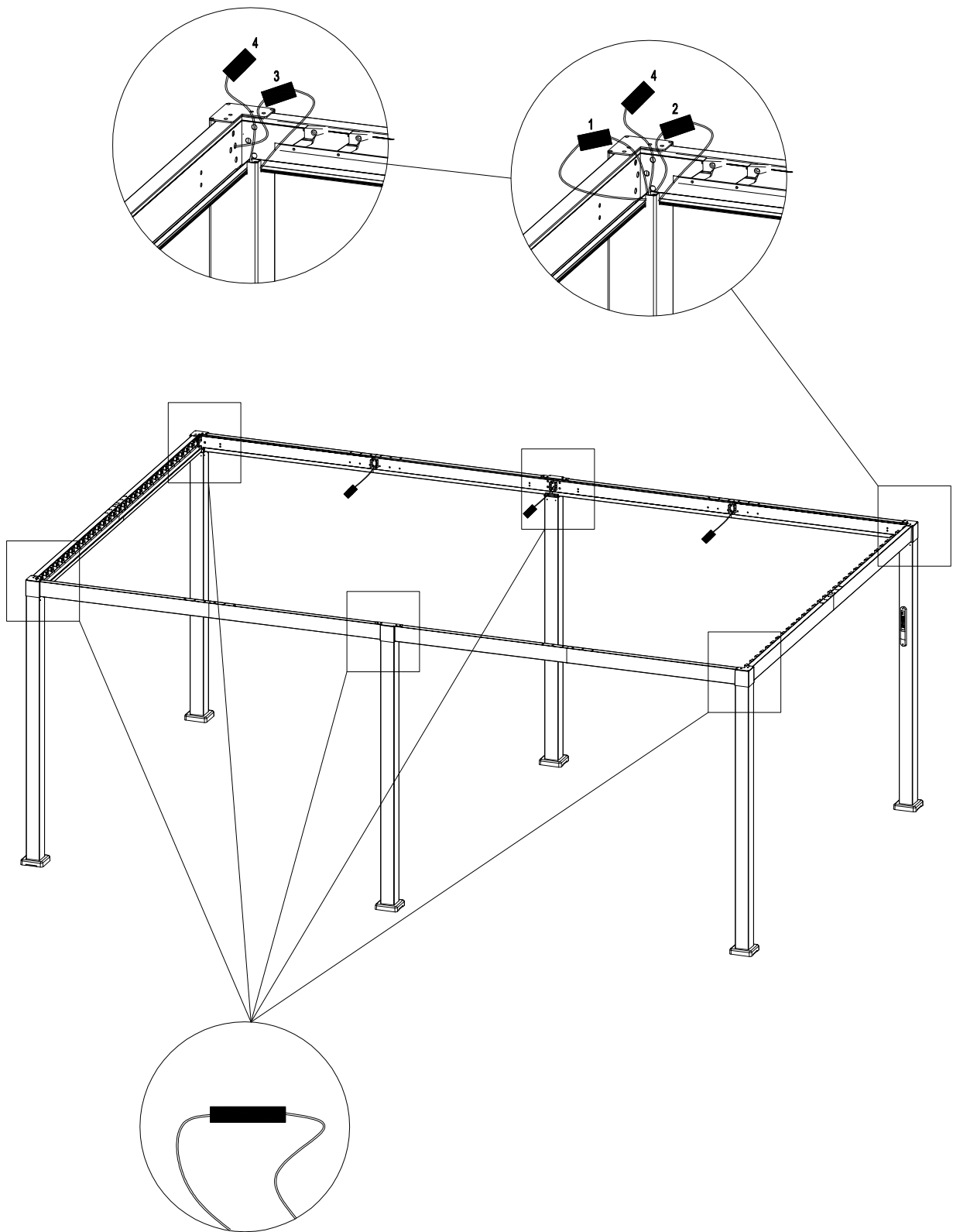

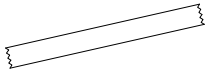

L1 X6

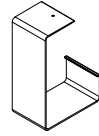

L3 X6

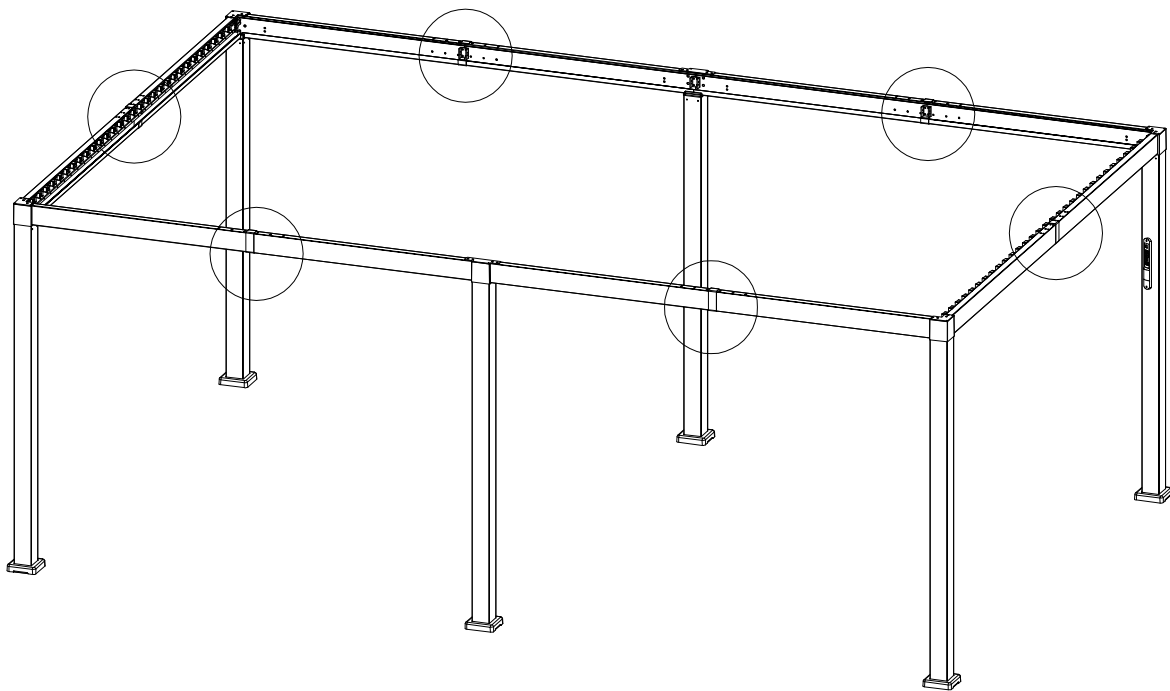
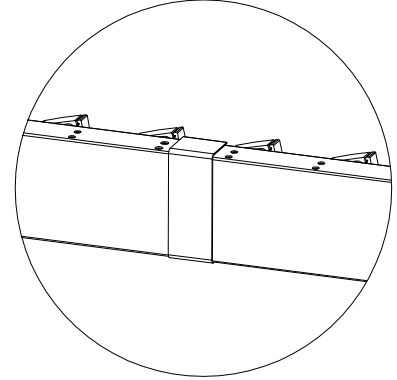
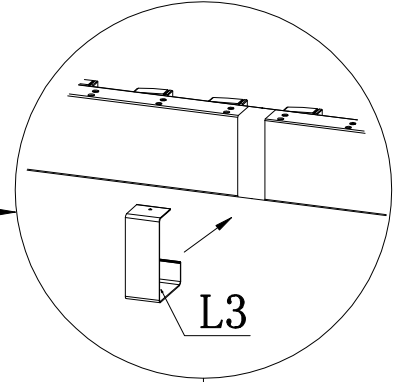
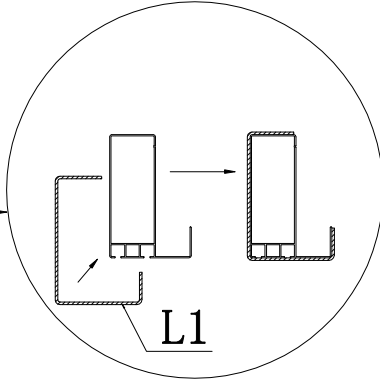
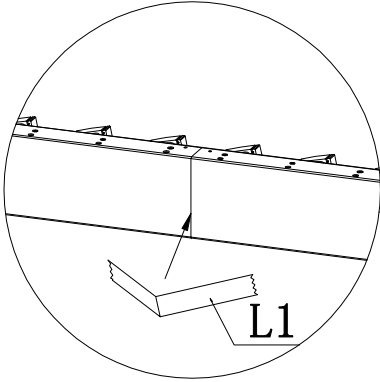



M X6

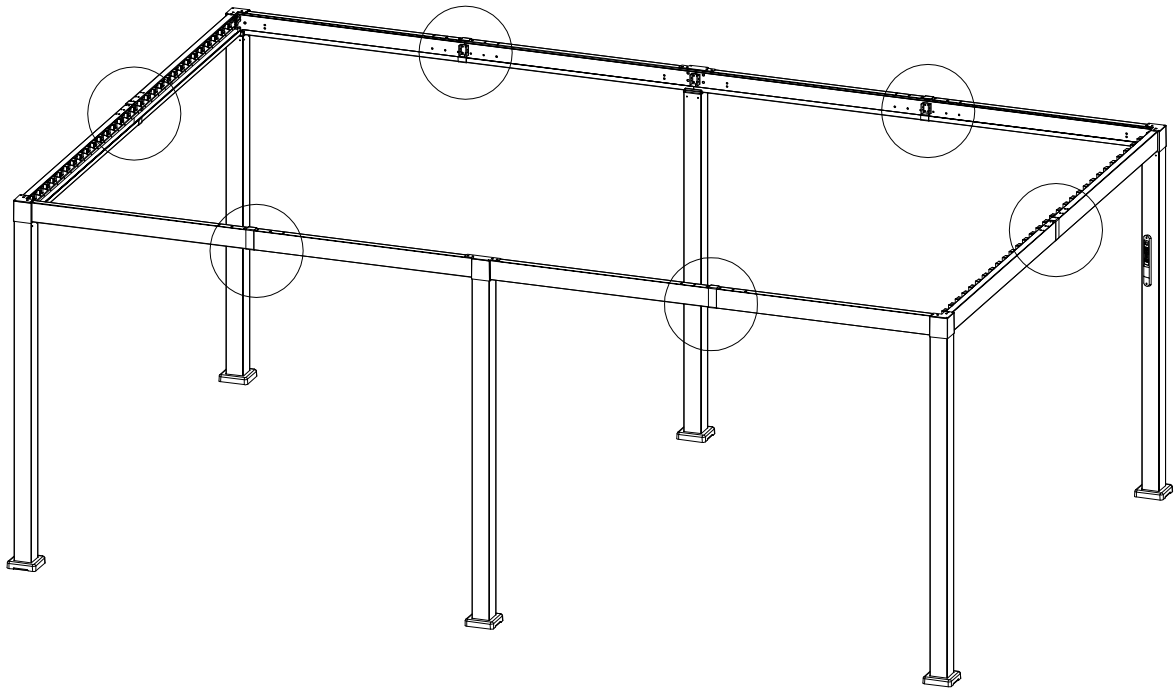
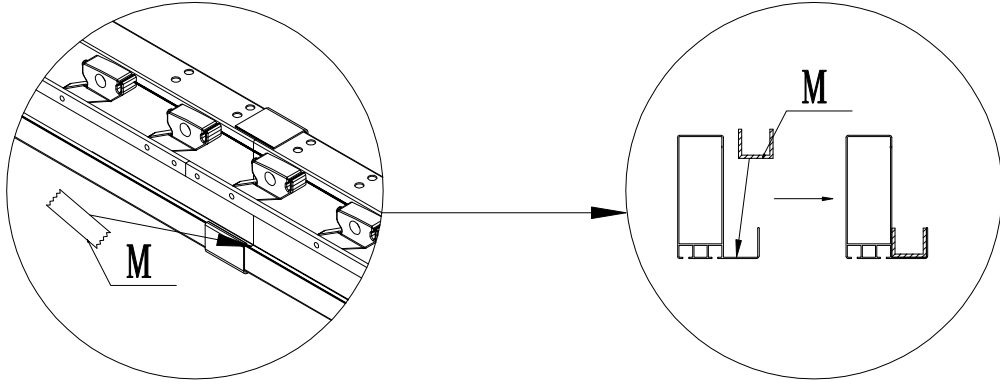

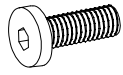

M6*15

1# X24

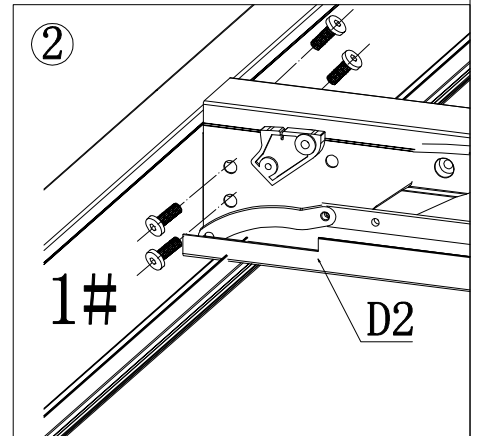
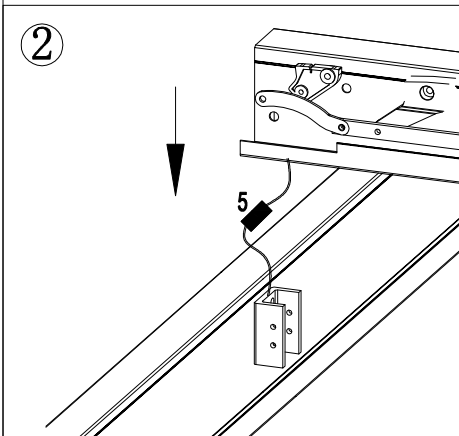
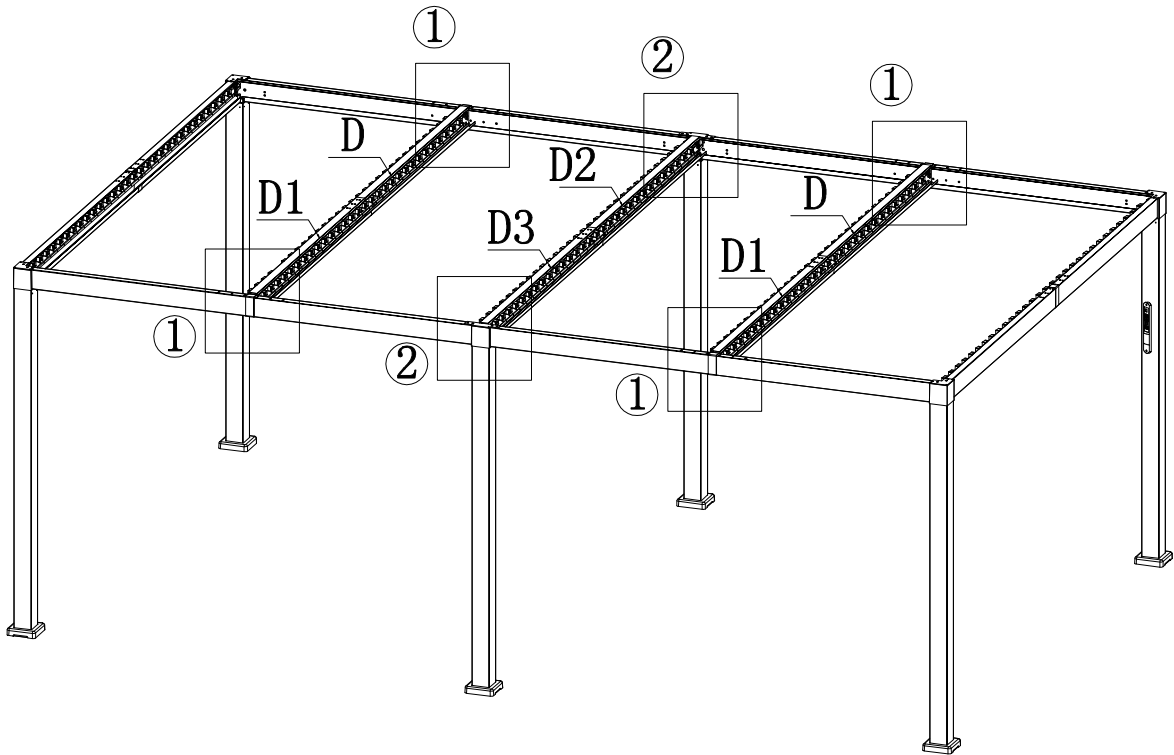
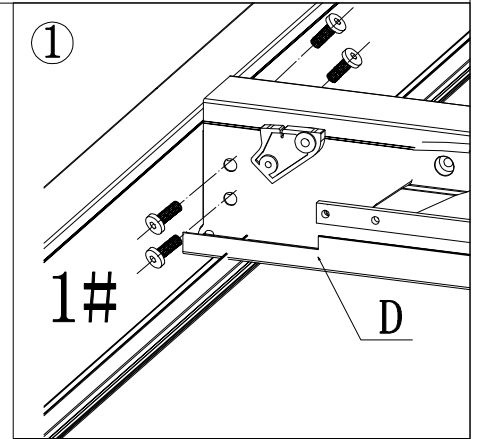
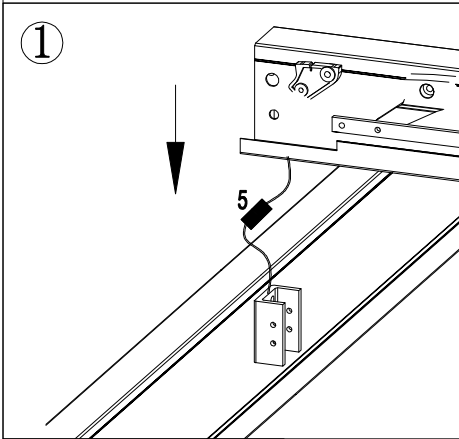

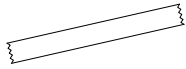

L X3

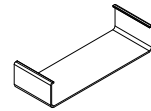

L2 X3

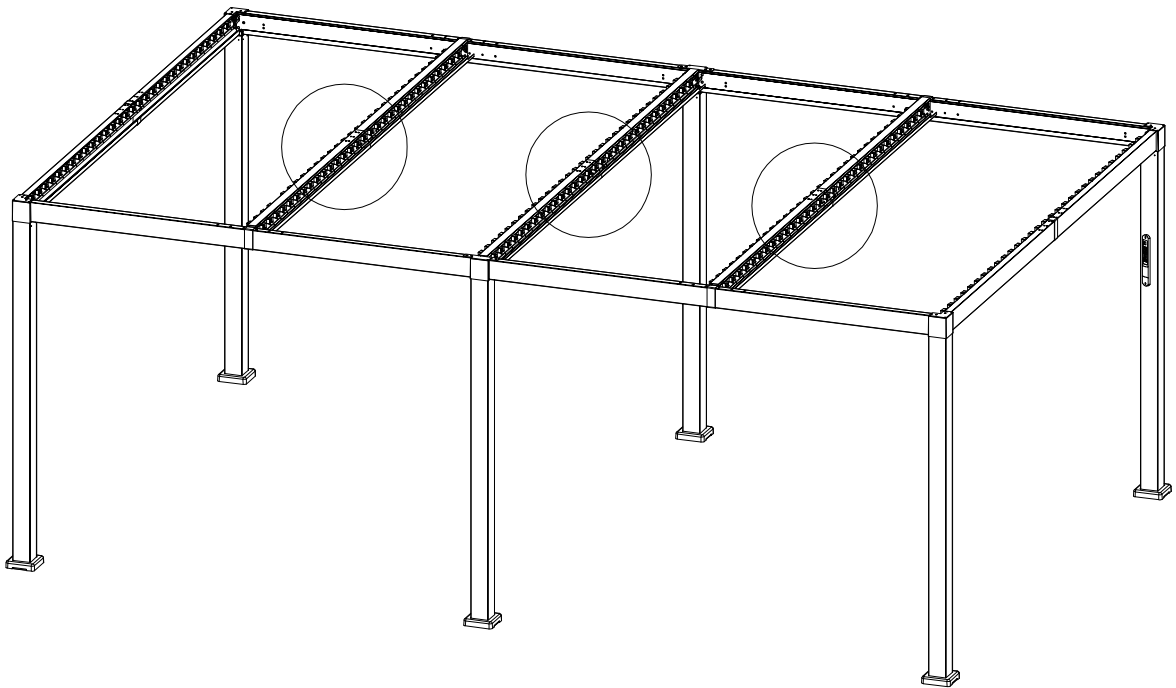
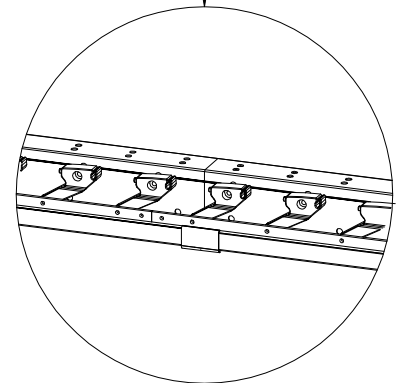
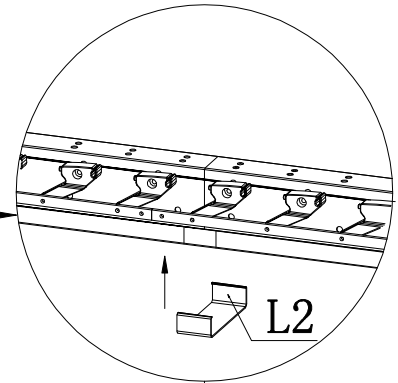
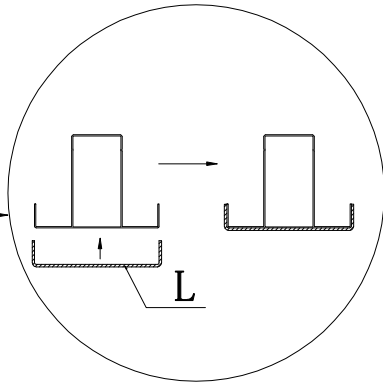
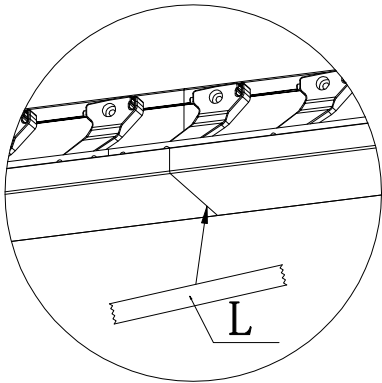



M X6

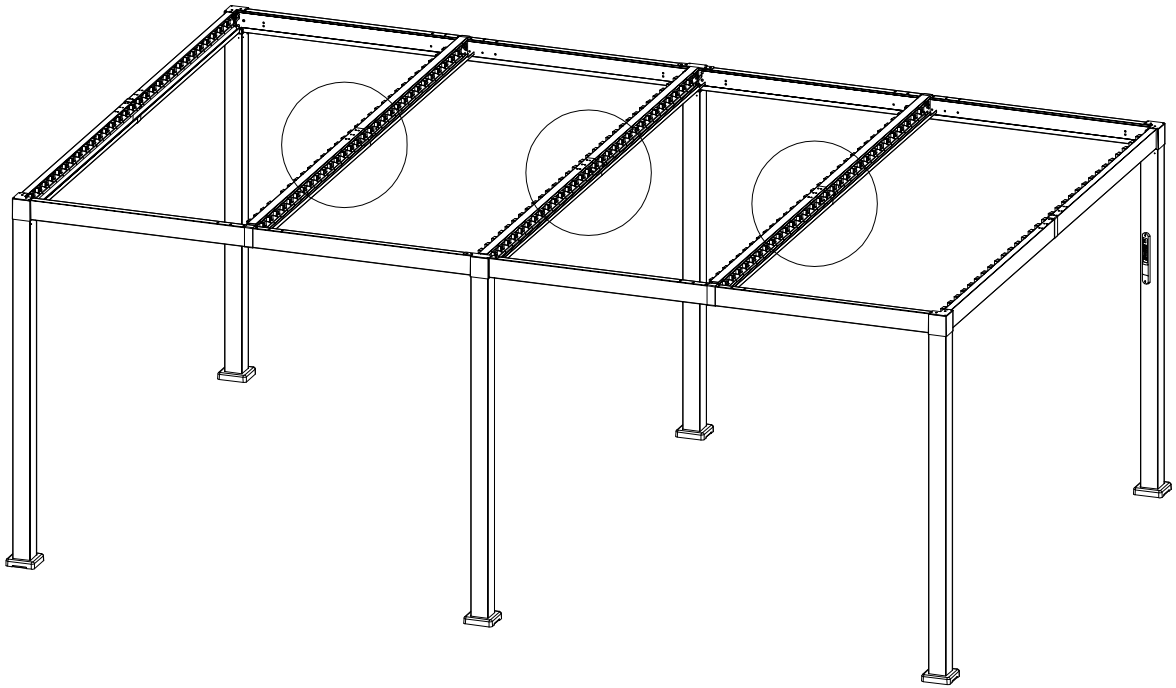
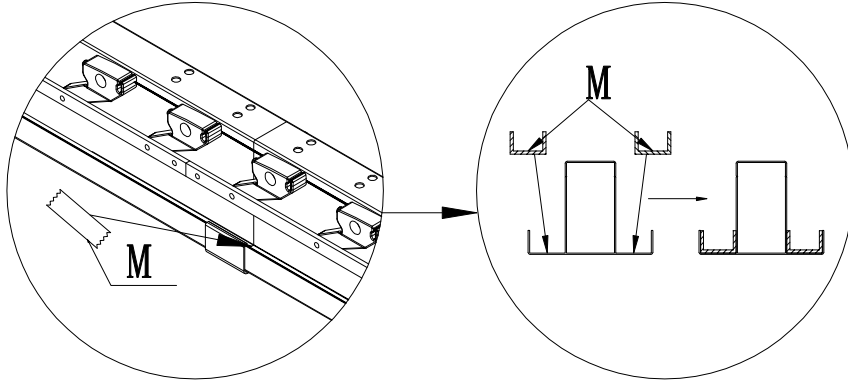

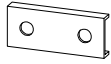

P X8

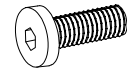

8# X16

①

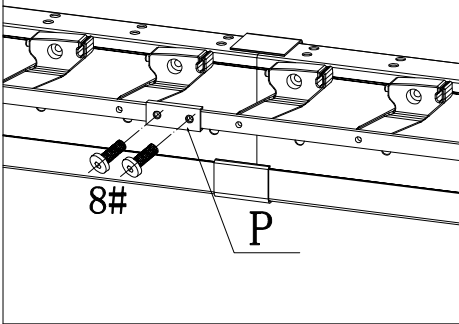

②

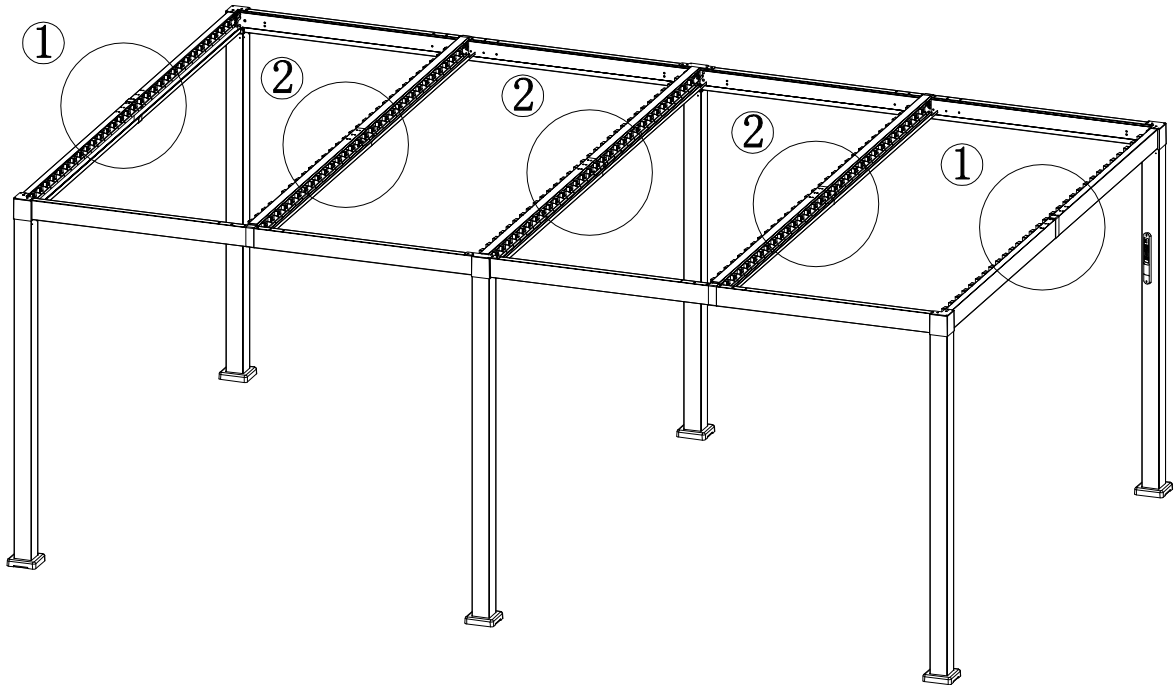
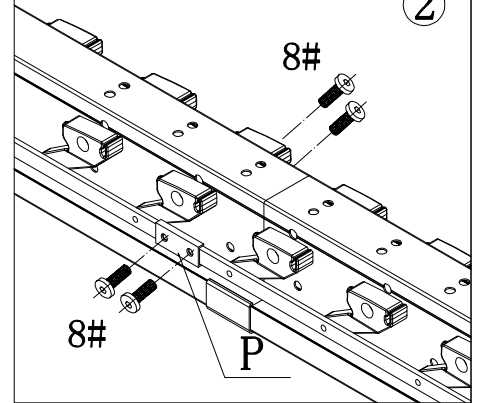

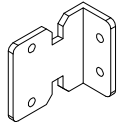

K1 X4

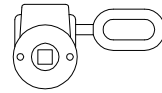

K X4

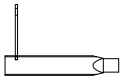

I1 X4

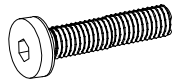

7# X8



6# X8

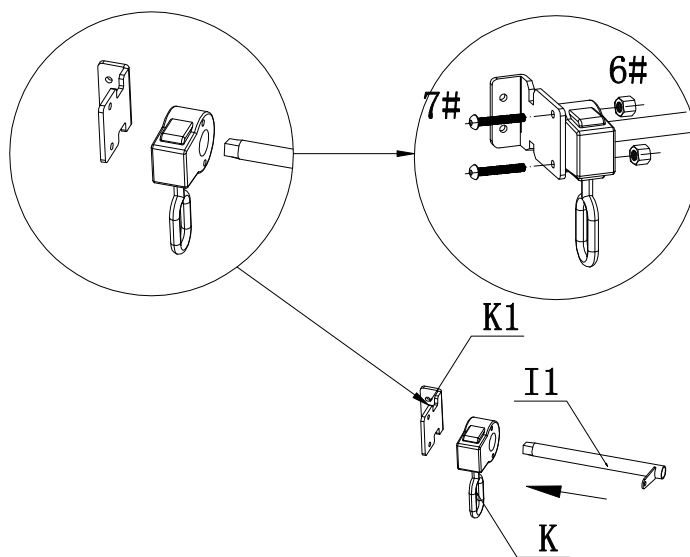
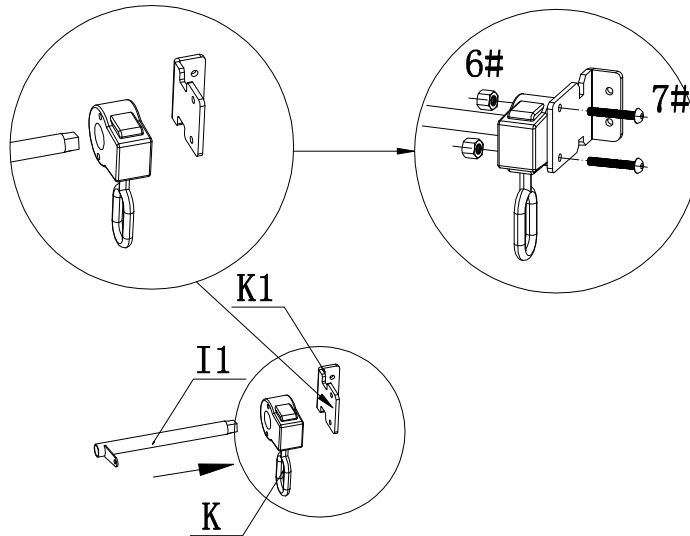

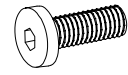

1# X8

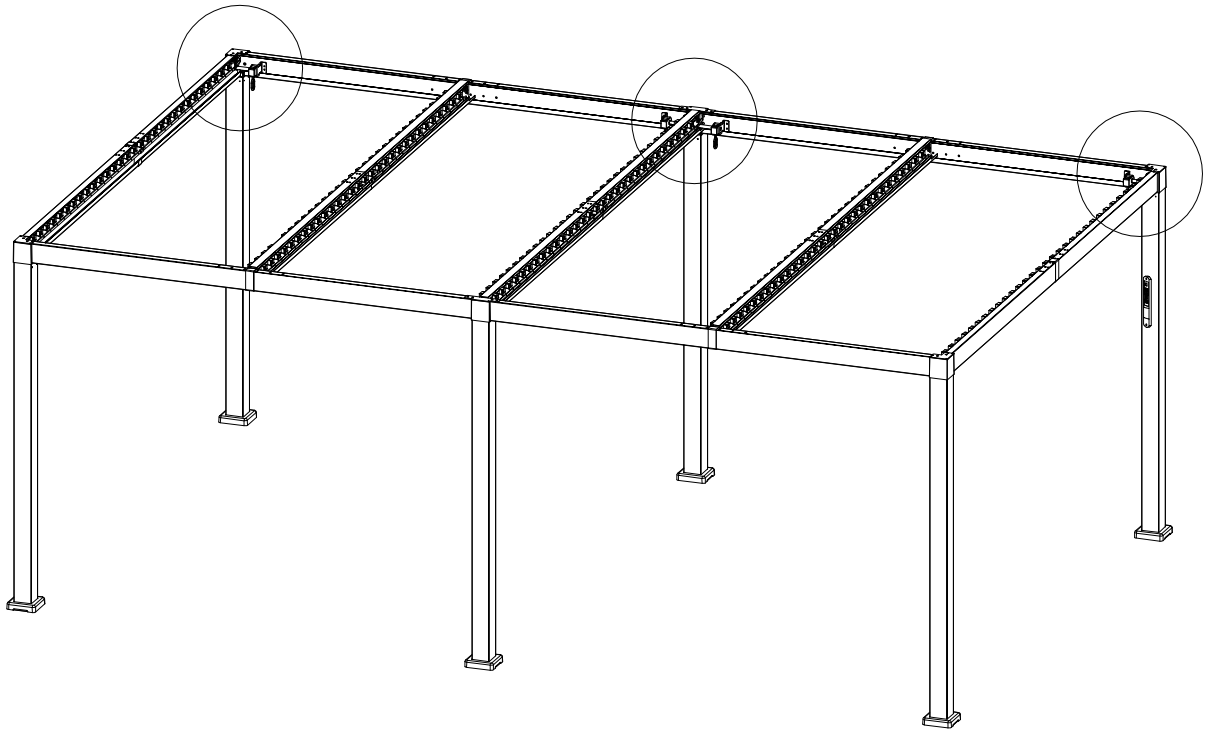
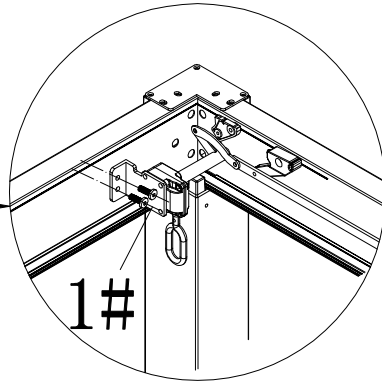
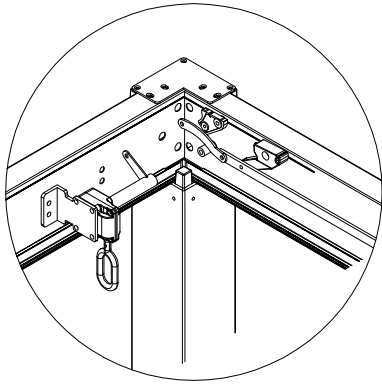

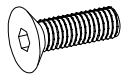

M6*15

5# X4



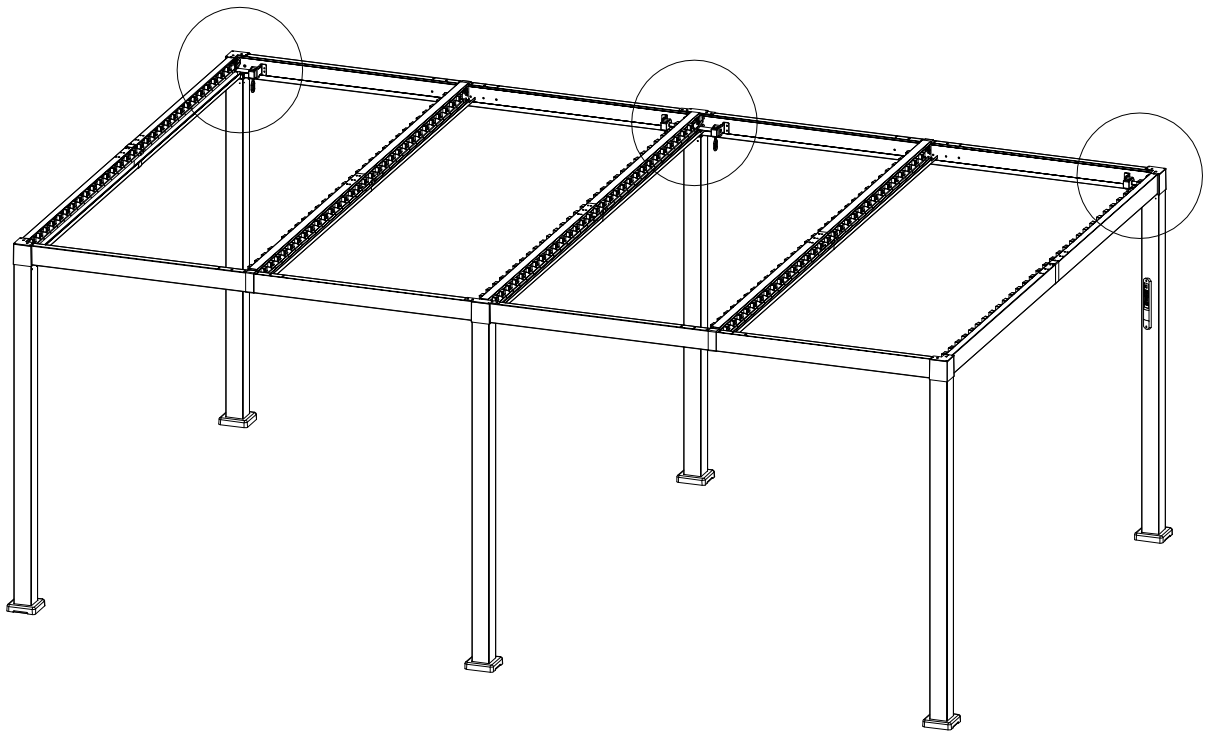
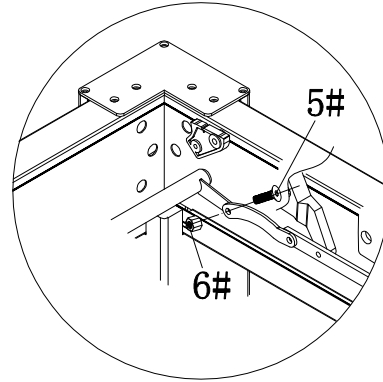

M6

6# X4

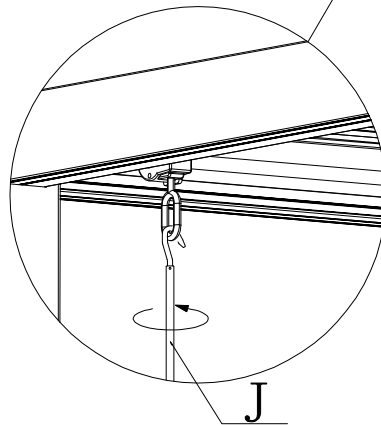
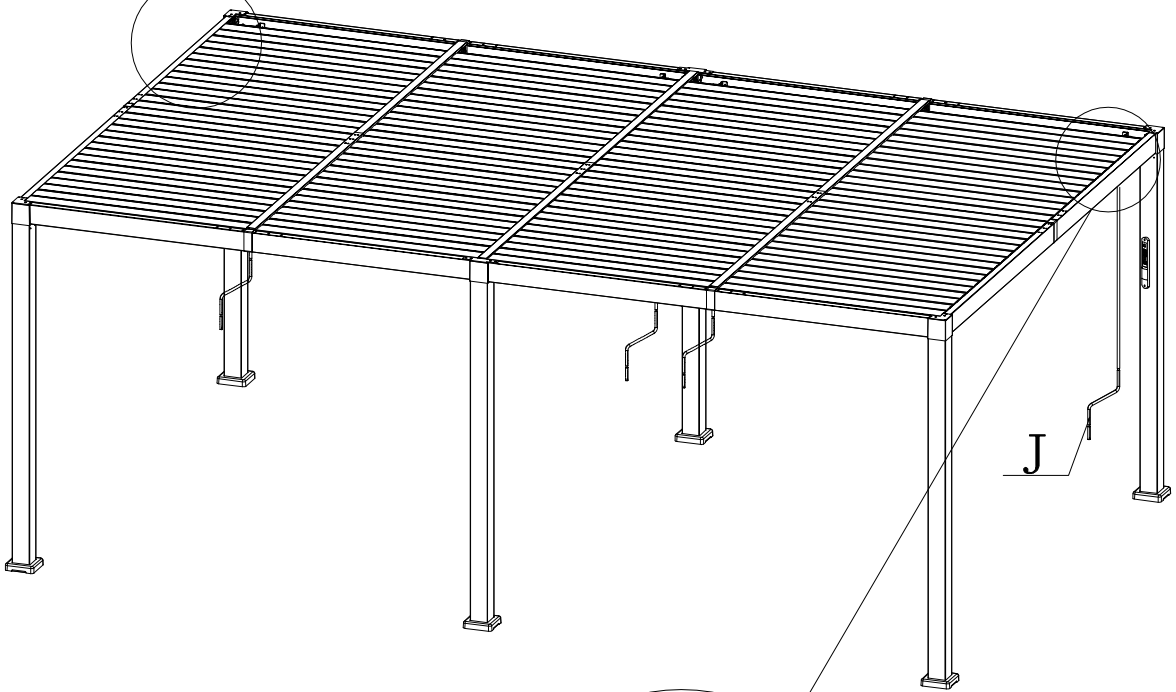
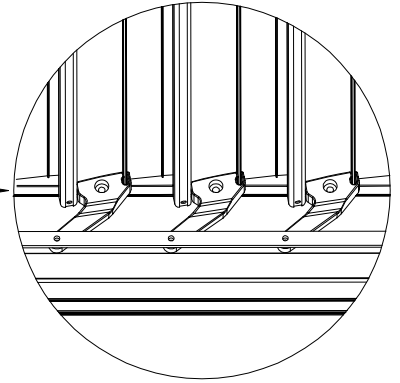
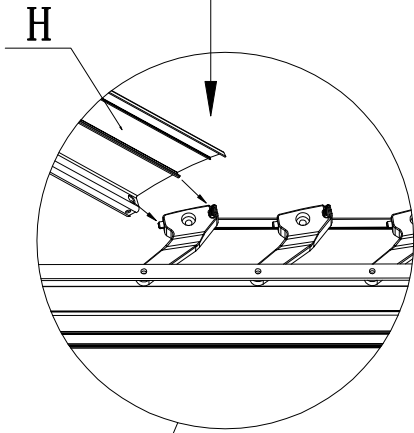

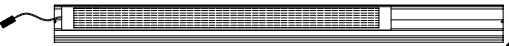

 <p>G X3</p>	 <p>4# X8</p>
 <p>G1 X1</p>	

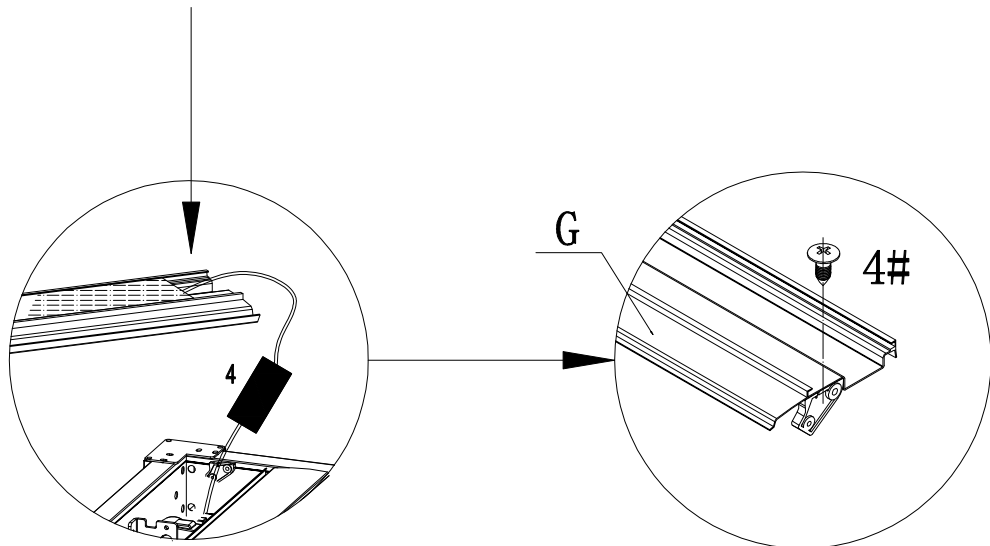
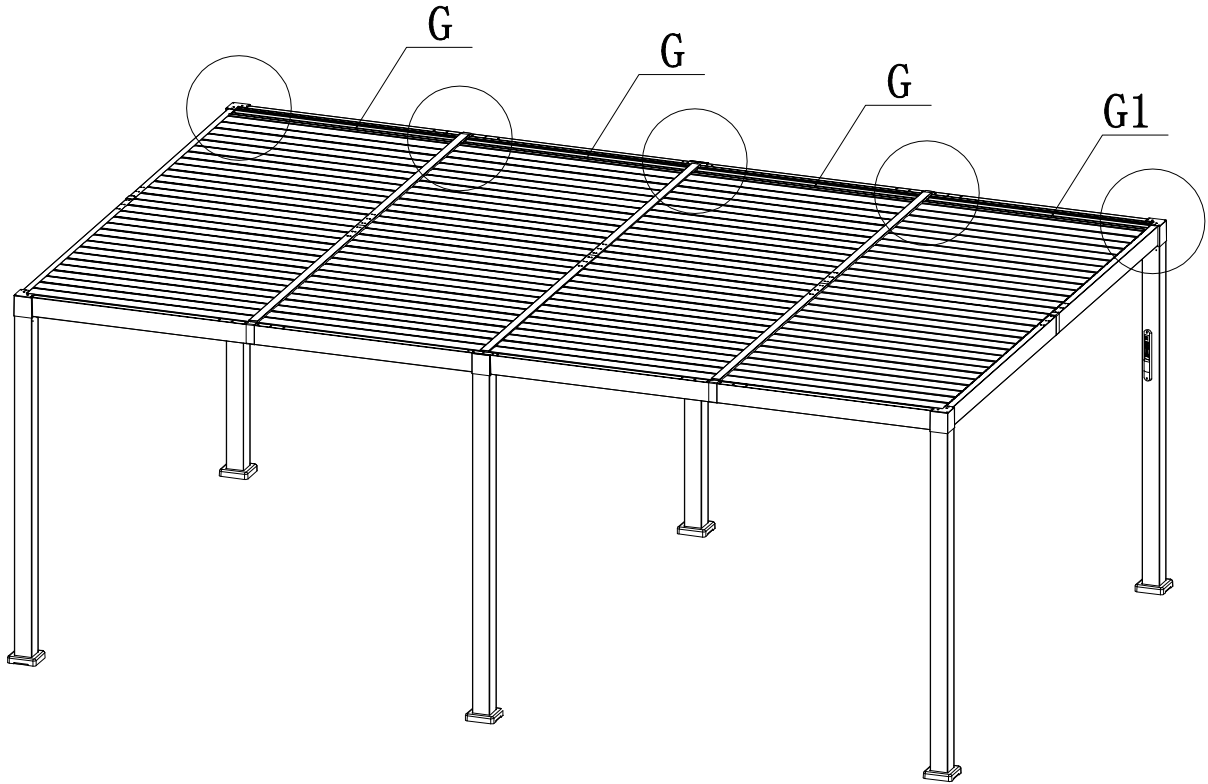



M8

9#X18

