

Ahokua

Assembly Instruction

Accent Cabinet

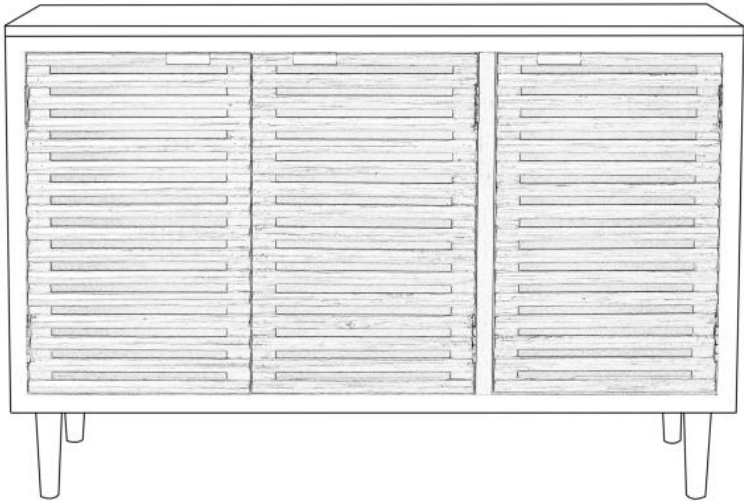













WARNING:

- Read all instructions carefully and completely before assembly and use.
- Retain for future reference.
- **DO NOT use power tools.**
- **DO NOT over-tighten hardware.**
- Periodically check all hardware and re-tighten as necessary.
- DO NOT use product if any component becomes damaged.
- For residential (non-commercial) use only.
- DO NOT sit or stand on product. Use only for intended purpose.
- DO NOT exceed 80lbs for the tabletop and 30lbs for the shelf, evenly distributed.

Parts List

Check all parts before assembly

A. <u>Tabletop</u>  *1	B. <u>Front panel</u>  *1	C. <u>Back panel</u>  *1	D. <u>Side panel</u>  *2	
E. <u>Bottom panel</u>  *1	F. <u>Shelf</u>  *1	G. <u>Leg</u>  *4		
H1. <u>Hex bolt</u>  *12(+1 extra)	H3. <u>Washer</u>  *12(+1 extra)	H3. <u>Alley key</u>  *1	H3. <u>Foot pad</u>  *4	H6. <u>Shelf pin</u>  *4

Step 1: Put the Tabletop (A) on a soft surface to protect the finish. Attach Front panel (B)&Back panel (C) to the Top (A) with Hex bolts (H1) & Washers (H2) using Allen key (H3). Ensure the panel (B&C) aligned with the groove on Top(A). **Leave hardware loose in this step.**

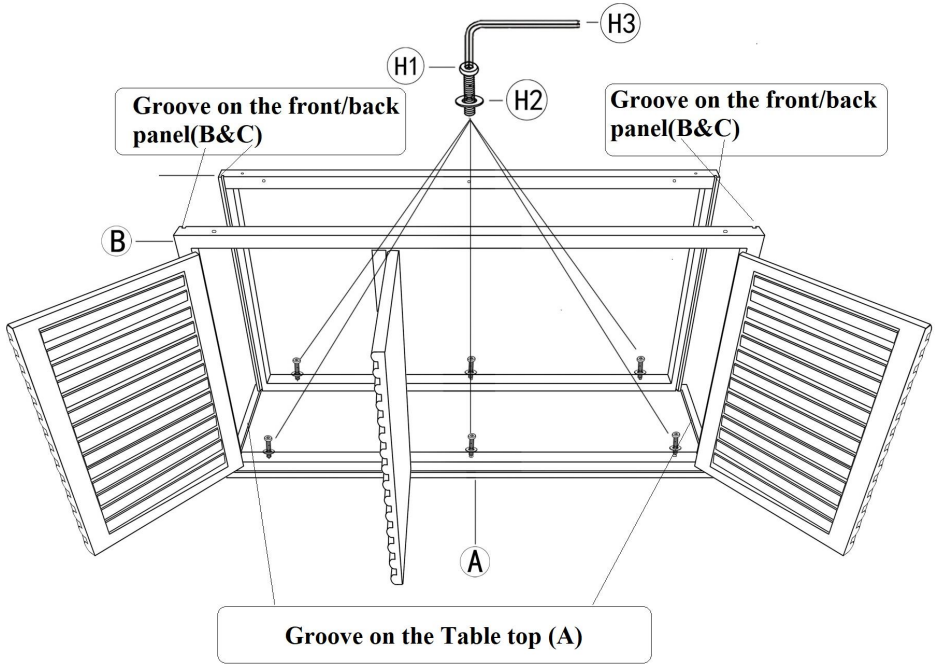

Step 2: Insert the Side panels (D) as shown below. Ensure the side panel (D) aligned with Groove on the Front panel (B)&Back panel (C). **Leave hardware loose in this step**

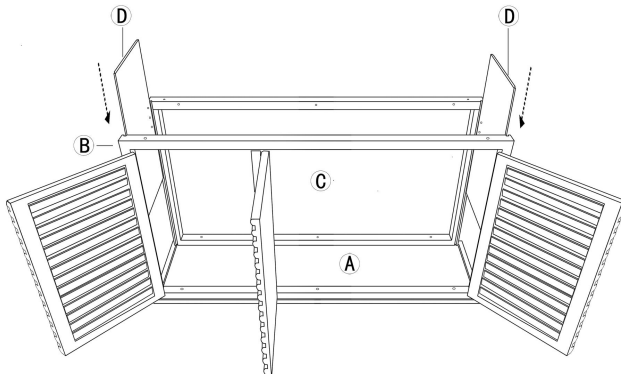

Step 3: Attach the Bottom panel (E) with Hex bolts (H1) and Washers (H2) by Allen key (H3) as shown in picture below. Note doorstop on E faces toward open front. **Fully tighten all bolts from Step 1 to 3.**

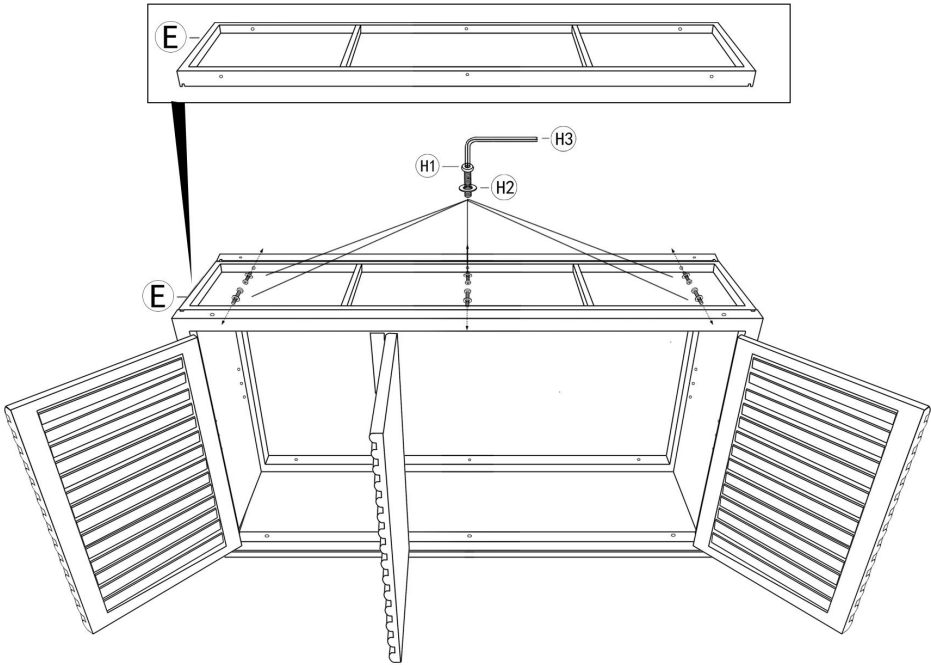

Step 4: Insert the threaded end of the Legs (G) into the Tabletop(A) and turn it clockwise to tighten. Attach the Foot pad(H4) to the bottom of the legs.

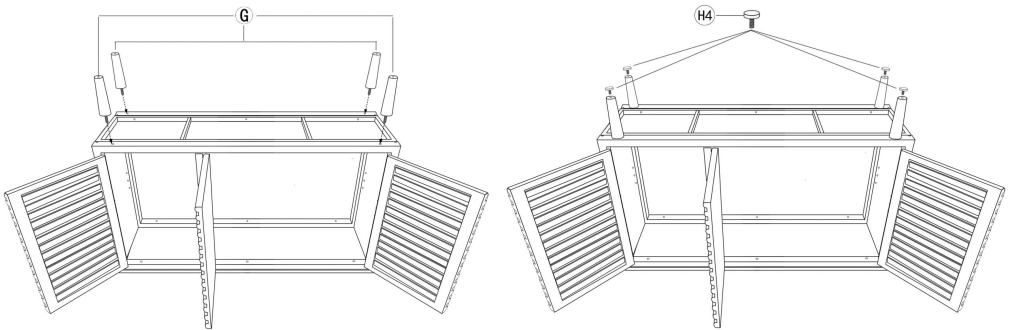

Step 7: Open the doors, insert the Shelf pins (H5) into the holes. Place the Shelf (F) inside as shown in picture below. (Each side panel with 6 adjustable holes.)

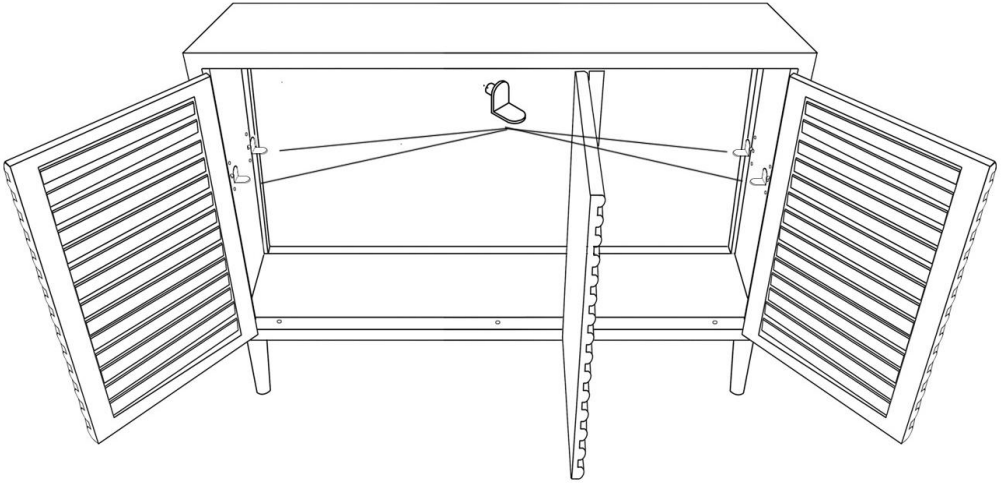

This side closer to the Back panel C

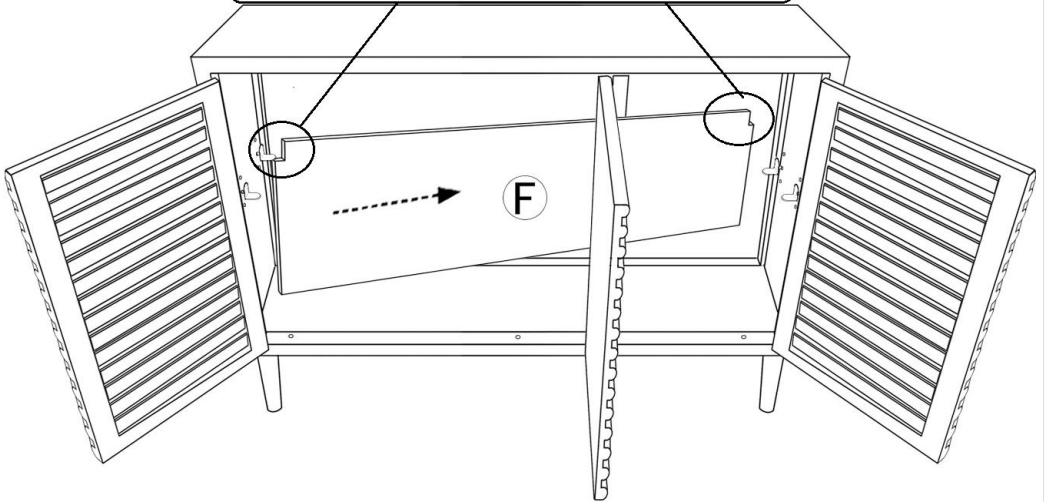

Assembly finished.

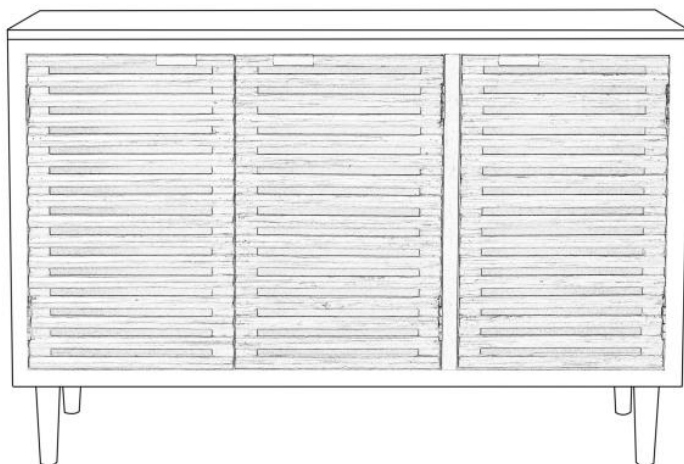

Notice:

If you encounter any issues during installation or use, please email us at support@mi-din.com, including your order ID and a detailed description of the problem. If possible, please provide relevant images to expedite assistance. We will strive to resolve any issues promptly.