

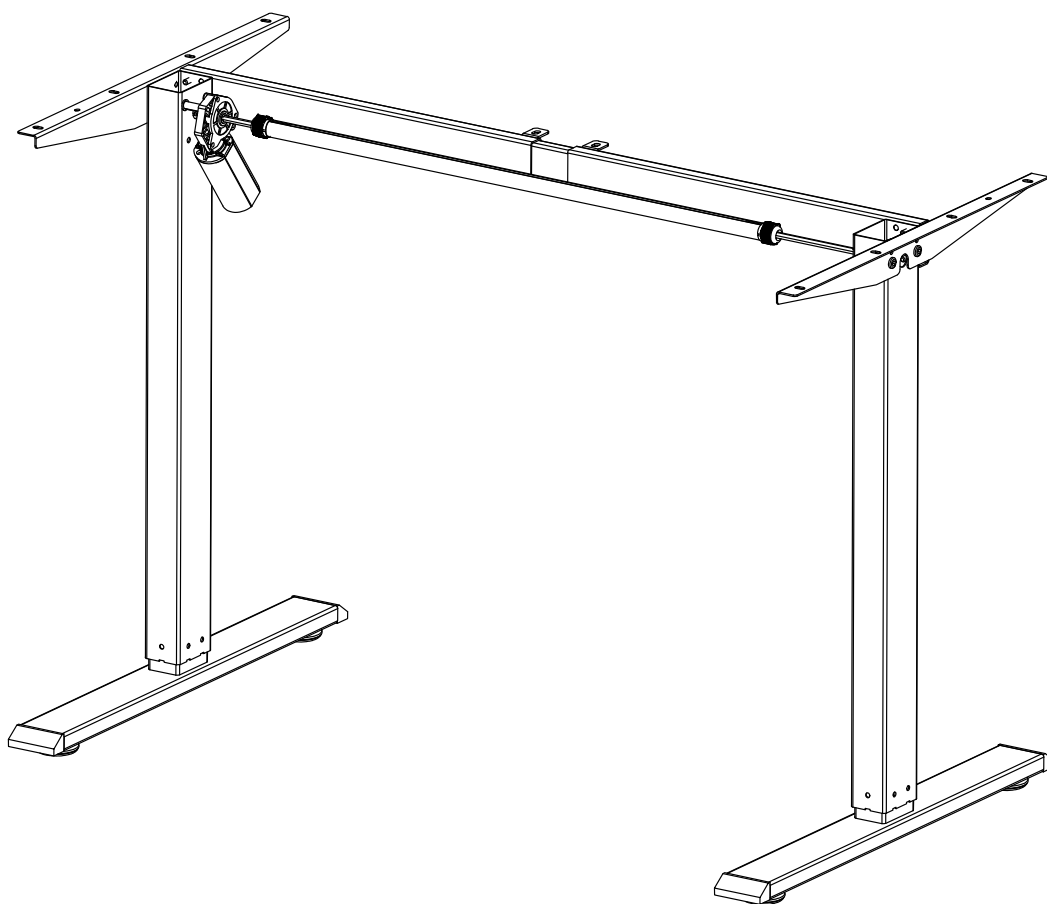

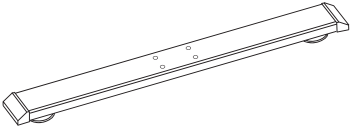

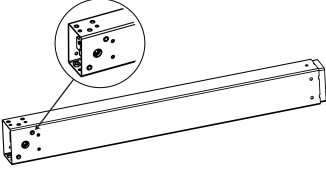

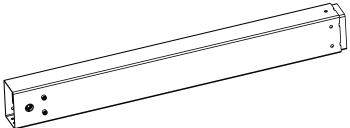



# *Instructions*

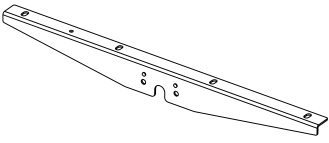
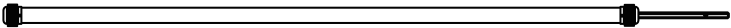

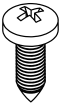
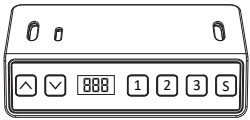
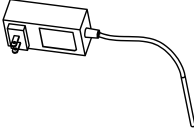
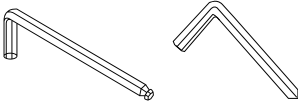
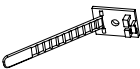
1. Accessory List .....	page 2
2. Foot installation.....	page 3
3. Motor installation.....	page 3
4. Beam installation.....	page 4-5
5. Drive rod installation.....	page 5
6. Side wing installation.....	page 6
7. Line connection.....	page 6
8. Panel installation.....	page 7
9. Hand control instruction.....	page 8-9

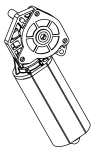
# DESCRIPTION

 <p>A×2</p>	 <p>B×1</p>	 <p>C×1</p>
 <p>D×1</p>	 <p>E×1</p>	 <p>F×1</p>
 <p>G×2</p>	 <p>H×1</p>	
<p>M6*35</p>  <p>J×8</p>	<p>M6*12</p>  <p>K×26</p>	<p>ST4*16</p>  <p>L×2</p>
 <p>M×1</p>	 <p>N×1</p>	 <p>O×1</p>
 <p>P×2</p>	<p>ST5*16</p>  <p>Q×2</p>	 <p>R×1</p>
 <p>S×1</p>	<p>M4*40</p>  <p>T×2</p>	

# 1. Foot installation

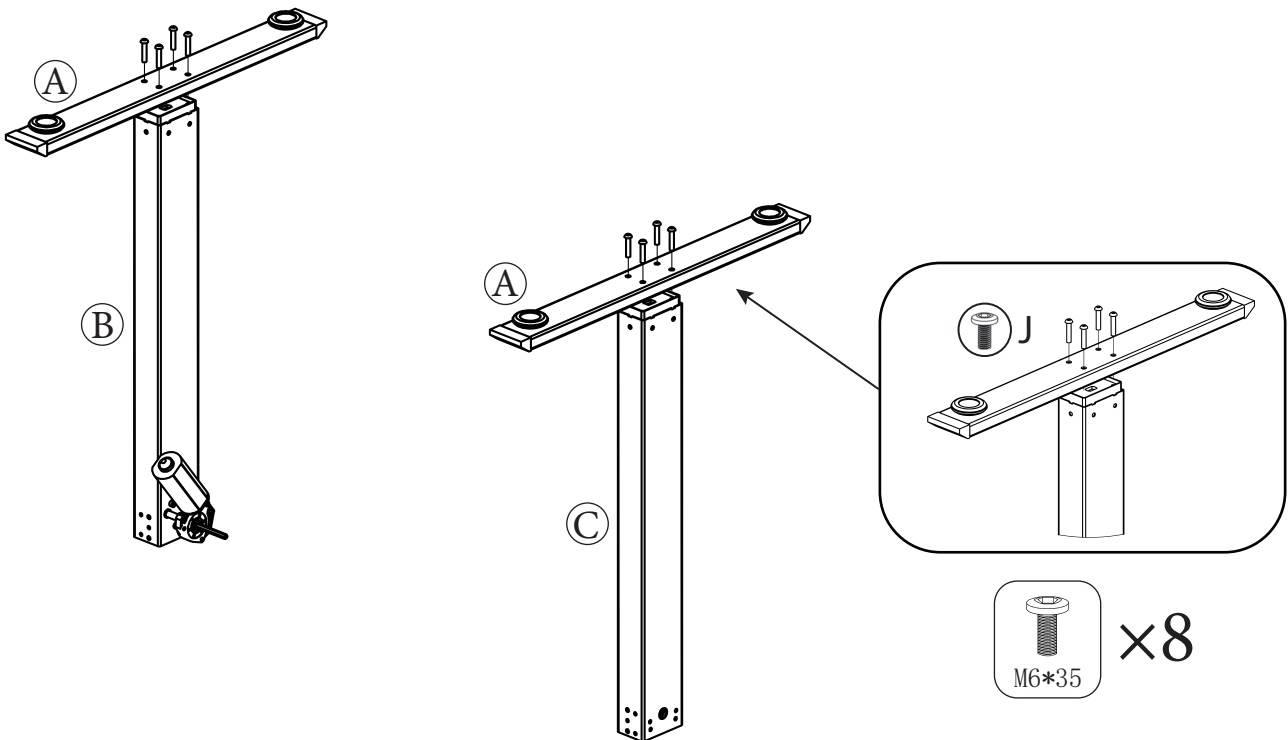

# 2. Motor installation

Step1

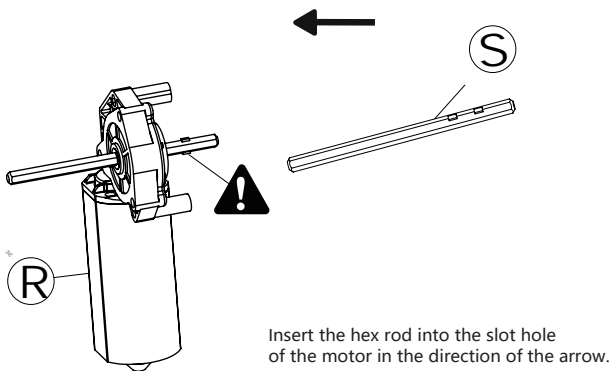

Step2

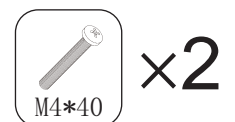
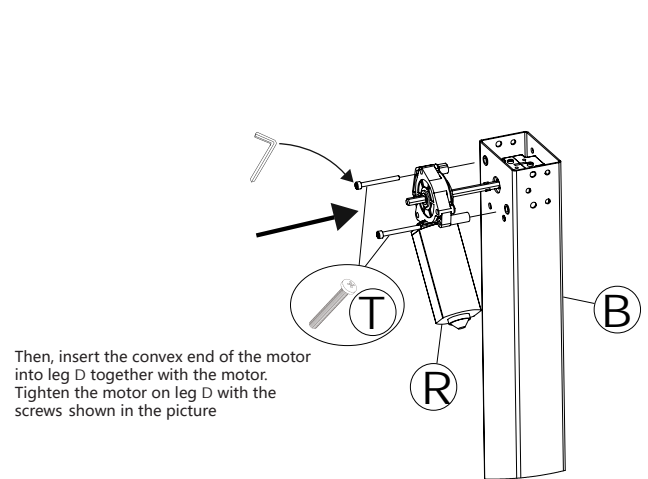

### 3. Beam installation (1)

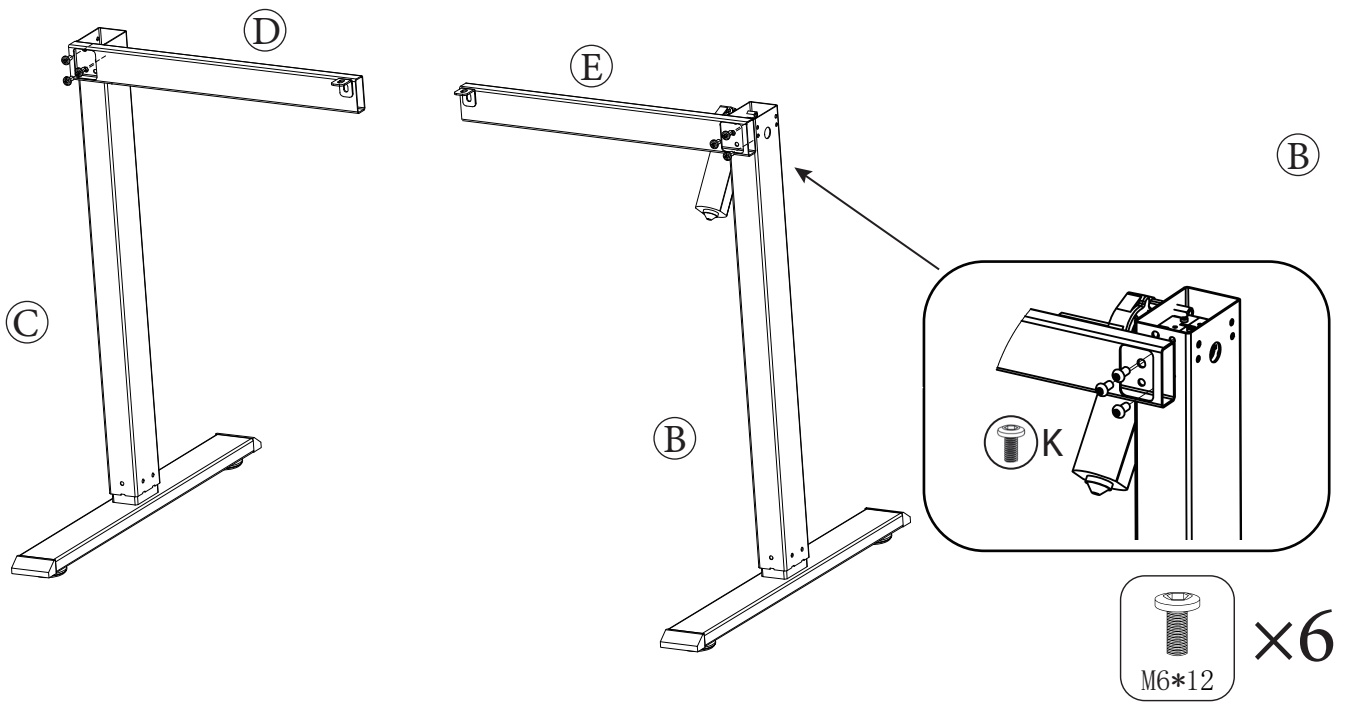

 The bending part faces up (the part with round hole is close to the panel)

### 3. Beam installation (2)

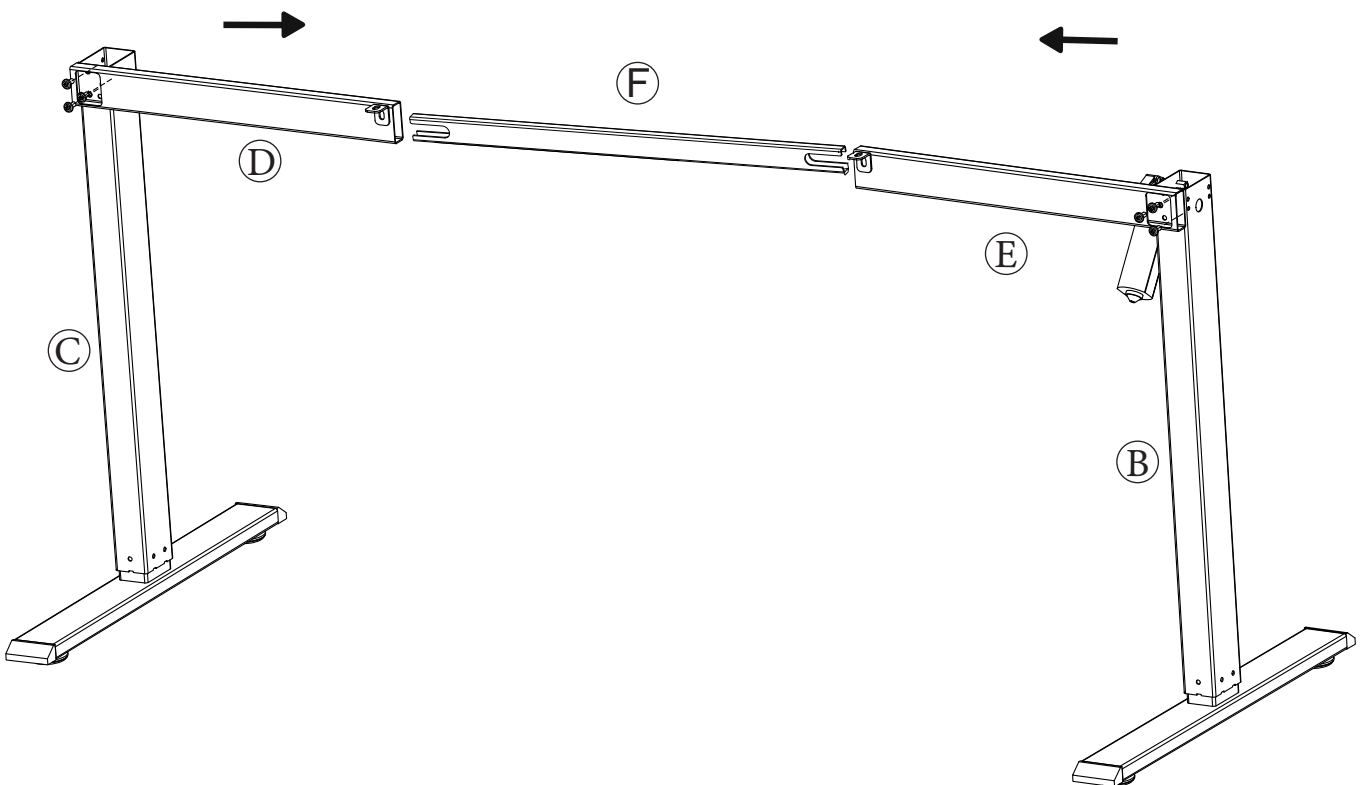

### 3. Beam installation (2)

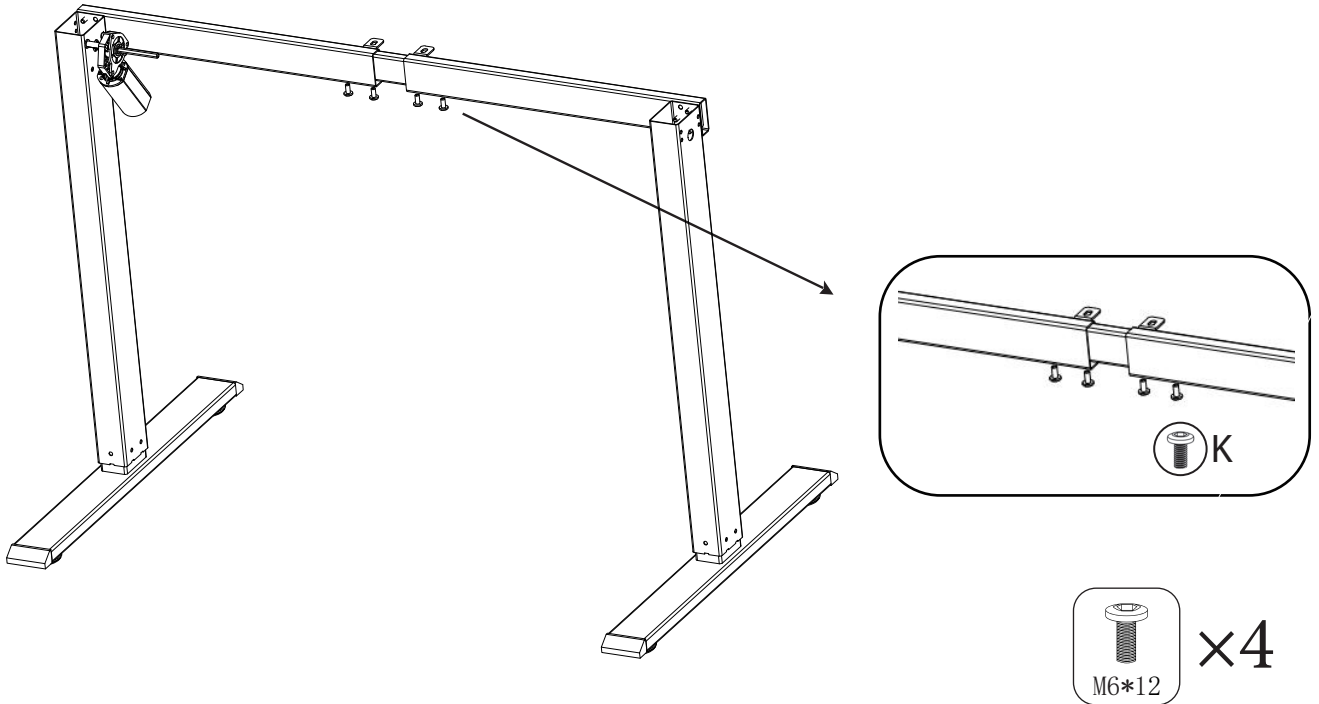

### 4. Drive rod installation

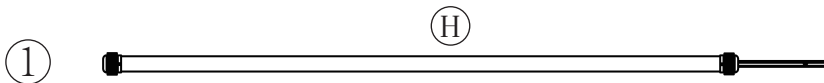

First, loosen the plastic nuts on both sides of the rod.

Second, Insert one end of the rod into the hexagonal bar of the motor, then pull out the hexagonal bar at the other end to the appropriate length and insert it into the gearbox on the other side.

② Finally, tighten the plastic nuts at both ends of the rod.

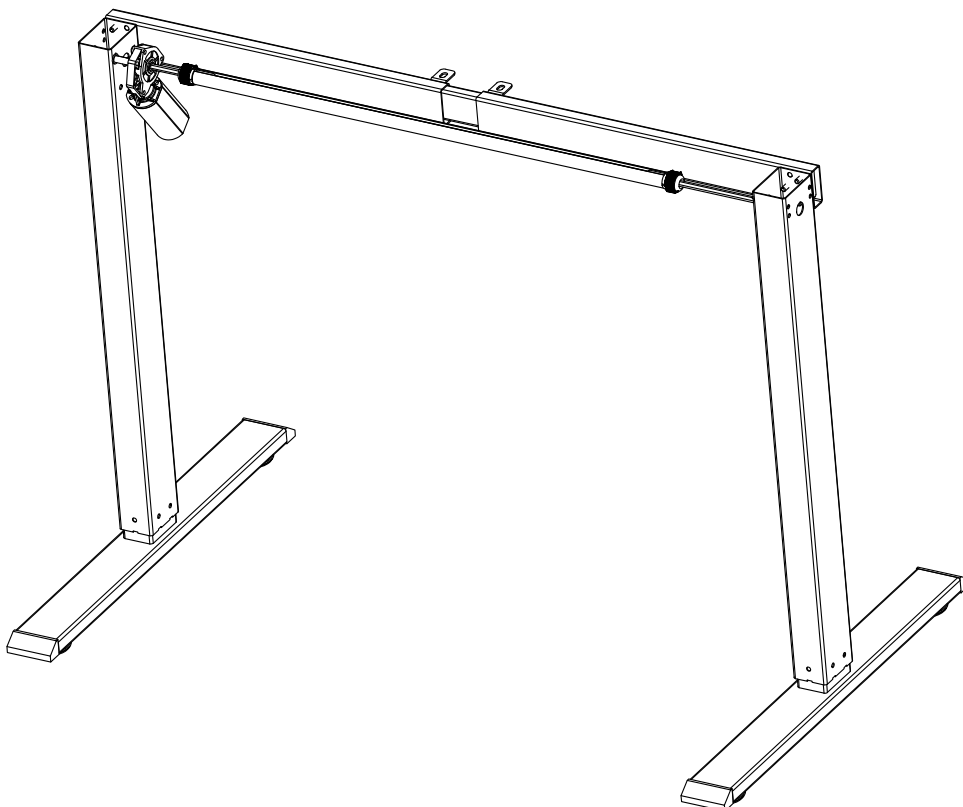

## 5. Side wing installation

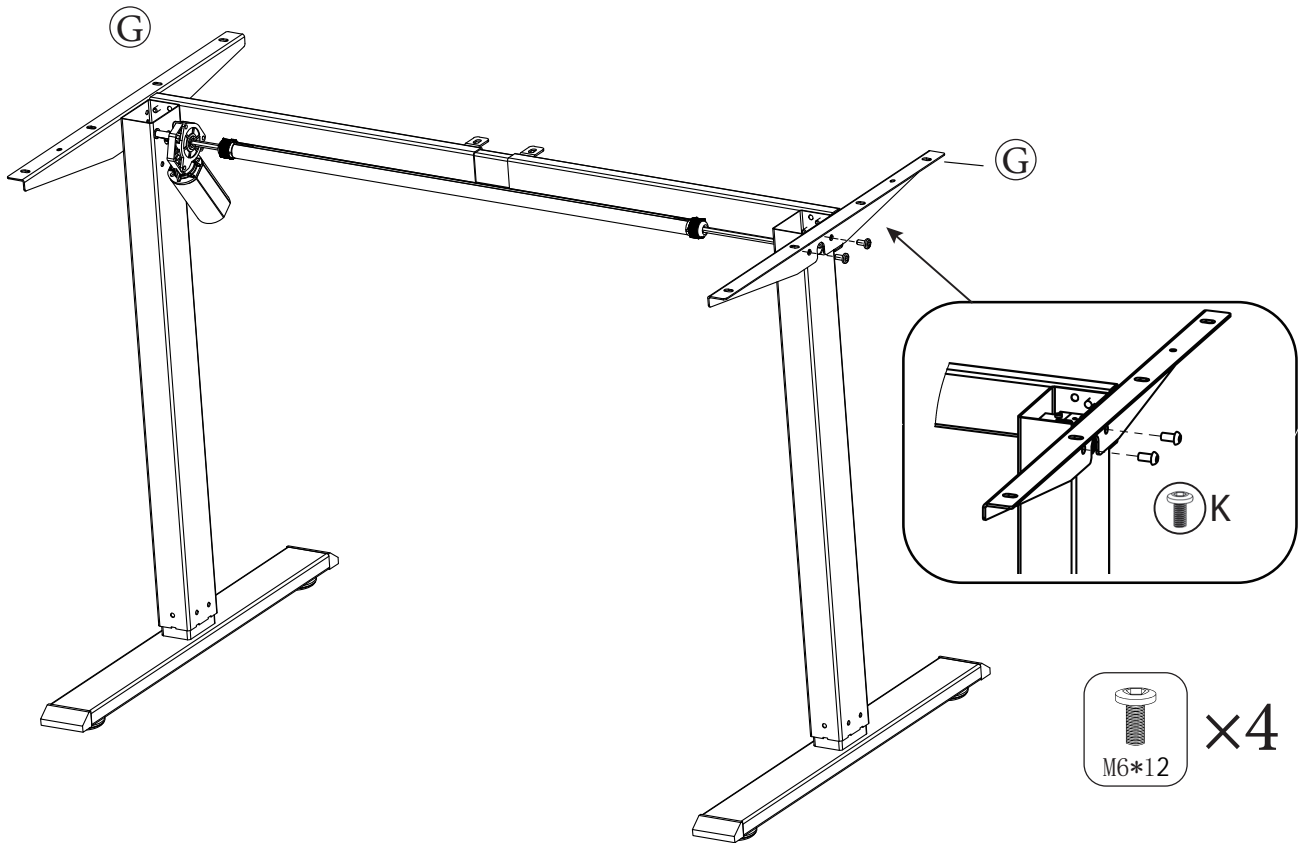

## 6. Line connection

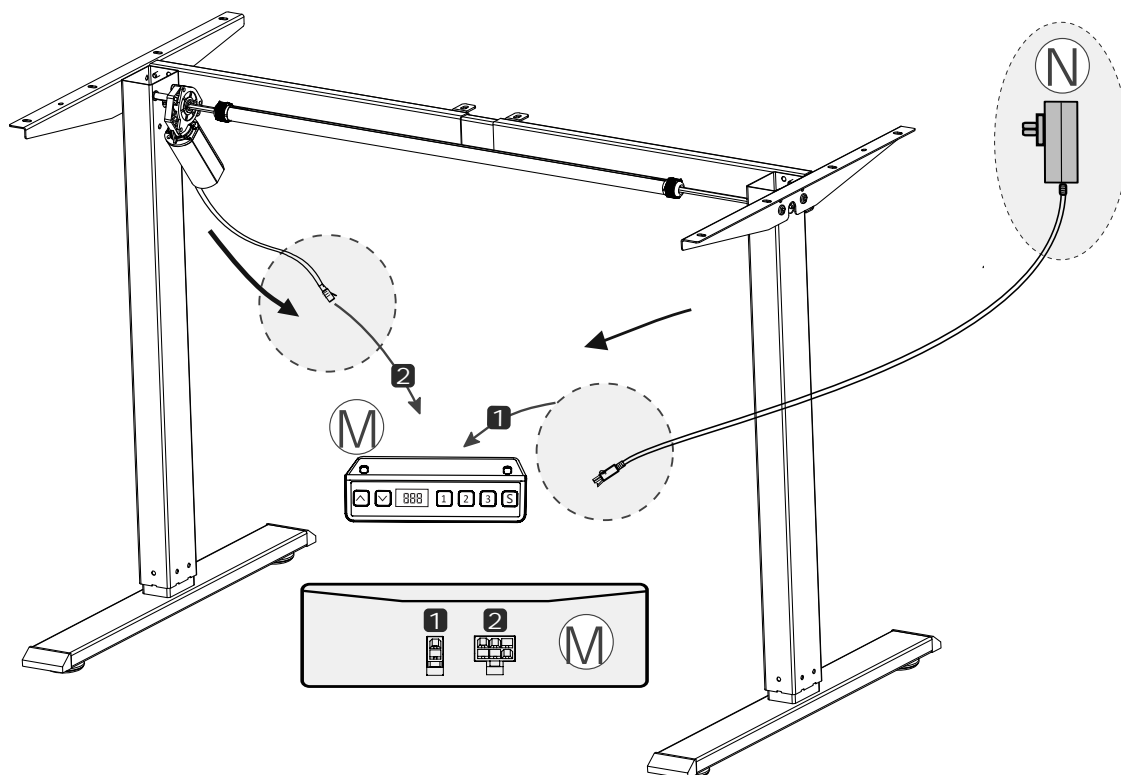

## 7. Panel installation

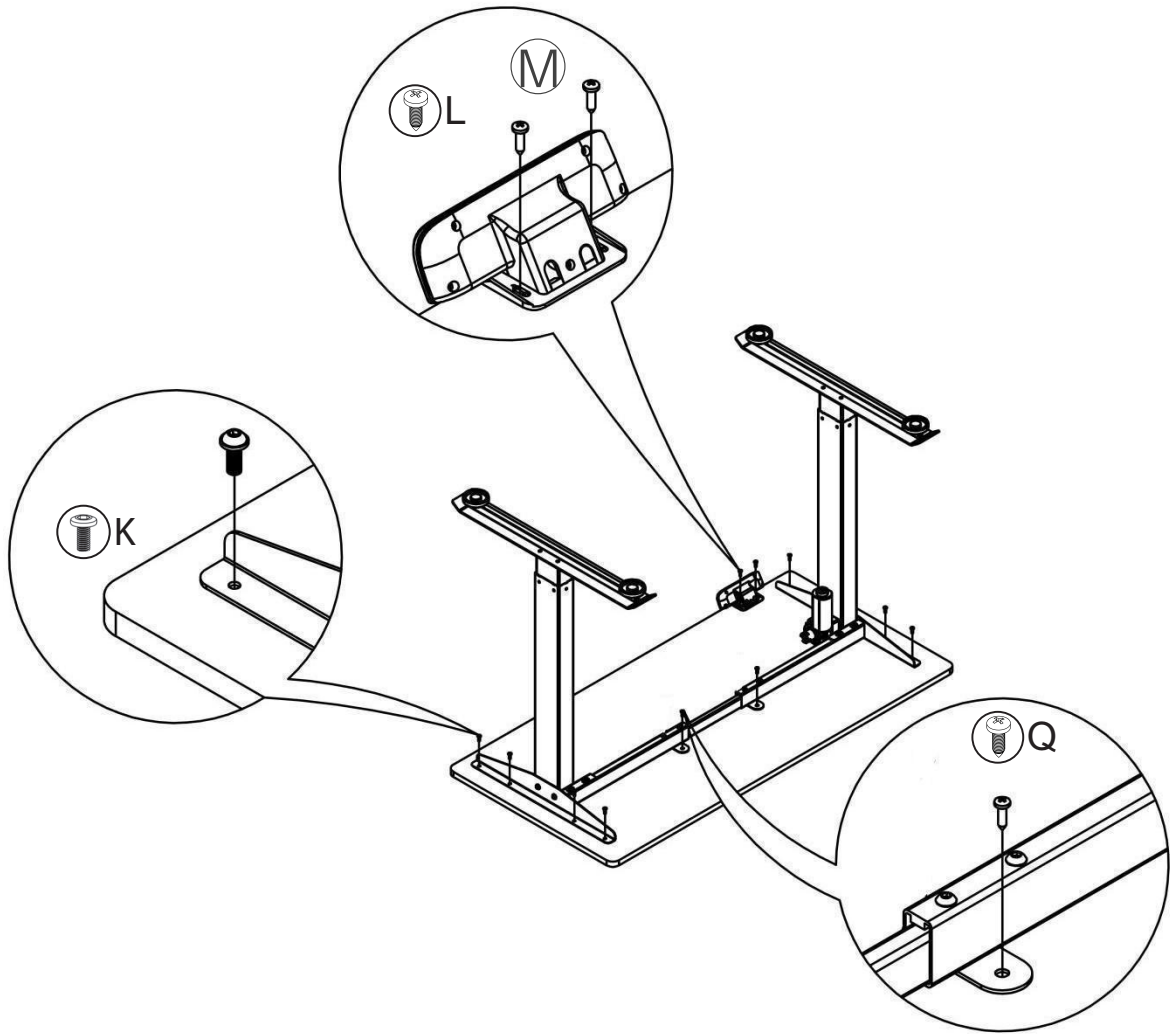

K  
M6\*12 × 8

L  
ST4\*16 × 2

Q  
ST5\*16 × 2

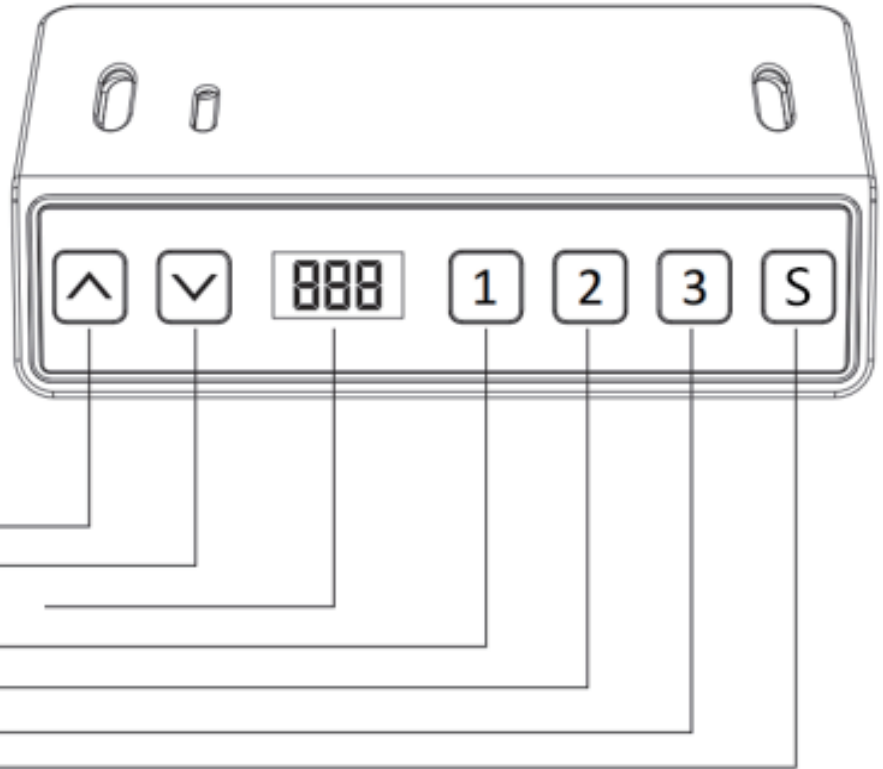

## Controller Introduction

- ◆ “ ^ ” : UP Key
- ◆ “ v ” : DOWN Key
- ◆ “ 888 ” : Display screen
- ◆ “ 1 ” : Memory Key 1
- ◆ “ 2 ” : Memory Key 2
- ◆ “ 3 ” : Memory Key 3
- ◆ “ S ” : Set Key

## Reset

- ◆ Press “ v ” until Controller shows “ - - - ” and flashes. Desktop automatically moves down to the lowest position, the desktop rebounds 3-5 mm after reaching the bottom. The controller shows “75.0” and you can hear beep. Complete reset.

## Up and Down Operation

- ◆ When the “ ^ ” key is pressed, the desktop runs upwards until it reaches its highest position. When the “ v ” key is pressed, the desktop runs downwards until it reaches its lowest position. When pressing the “ ^ ” or “ v ” key for a short time, the desktop will run a small distance to achieve jogging.

## Storage Position /Memory Position Operation

- ◆ Storage Position: It can Storage 3 memory position. The method is as follows: When running to a specific position, the screen will display the current height, press and hold the “1/2/3” key until the screen displays “ 5- 1 / 5- 2 / 5- 3 ” and flashes, the screen will display the current height again, and you can hear beep, the current height is successfully memorized.
- ◆ Memory Position Operation: Press the “1/2/3” key, the screen will flash for 2 seconds and the desktop will automatically run to the height of the memory position. During operation, press any key can stop the operation.

---

## Locking and unlocking

- ◆ Locking: Press and hold "^" + "v" + "2" at the same time for 5 seconds. When the display shows "L", it means that the system has been locked and the system cannot be up and down.
  - ◆ Unlocking: Press and hold "^" + "v" + "2" at the same time for 5 seconds. When the display shows from "L" to normal digital, it means that the system has been unlocked.
- 

## Error Code Table

Error Code	Illustrate	Handling method
E01	Motor not connected	Press the up or down key again, if it still exists, please check the connection wire of the column motor.
E02	Motor overcurrent	Press the up or down key again, if it still exists, please replace the motor or reduce the load.
E03	Motor Hall fault	Press the up or down key again, if it still exists, please check the connection wire or replace the motor.
E04	Abnormal main power supply	Unable to eliminate after electricity, replace the power.
E05	Abnormal motor current	Unable to eliminate after power failure and needs to be returned to the factory.
E06	Damaged motor power components	Unable to eliminate after power failure and needs to be returned to the factory.
E09	Motor stall	Press the up or down key again, if it still exists, please replace the motor or reduce the load.
Hot	Motor Overheat	Wait for the temperature to down, run for 2 minutes, stop for 18 minutes.
r5f	Abnormal loose power	Reduce the load or check if the power connection wire is loose.