

STAND MIXER ATTACHMENT PASTA ROLLER AND CUTTERS ATTACHMENT INSTRUCTION MANUAL

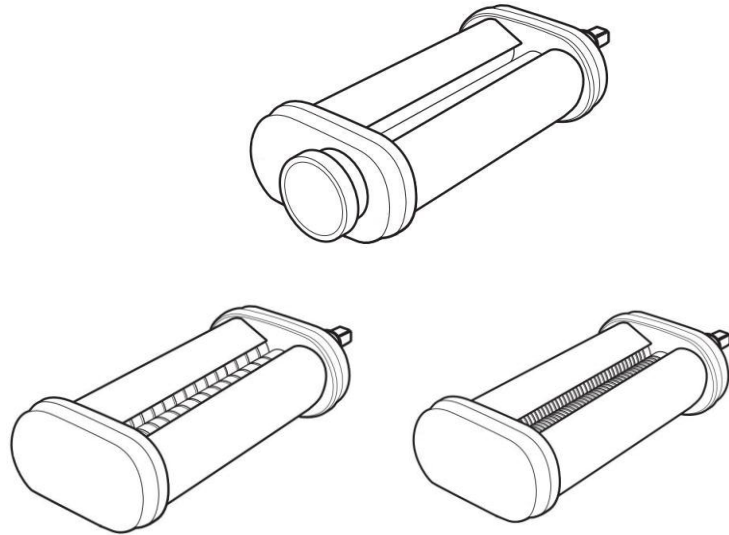

Before operating this unit, please read these instructions completely

SAVE THESE INSTRUCTIONS

This product is designed for household use only.

Your safety and the safety of others are very important.

We have provided many important safety messages in this manual and on your appliance. Always read and obey all safety messages.

⚠ This is the safety alert symbol. This symbol alerts you to potential hazards that can kill or hurt you and others. All safety messages will follow the safety alert symbol and either the word “DANGER” or “WARNING.”

These words mean:

You can be killed or seriously injured if you don't immediately follow instructions.

All safety messages will tell you what the potential hazard is, tell you how to reduce the chance of injury, and tell you what can happen if the instructions are not followed.

⚠ IMPORTANT SAFEGUARDS

When using electrical appliances and this attachment, basic safety precautions should always be followed, including the following:

1. Read all instructions.
2. This appliance is not intended for use by persons (including children) with reduce physical, sensory or mental capabilities, or lack of experience and knowledge, unless they have been given supervision or instruction concerning use of the appliance by a person responsible for their safety.
3. To avoid electric shocks, do not use this device in the vicinity of water. Do not immerse the stand mixer in water or other liquid.
4. Switch off the appliance and always disconnect the plug from the power socket (pull out the plug) after each use of the appliance and the attachment, before assembling the attachment and accessories, changing accessories, cleaning or in case of malfunction.
5. Do not use stand mixer and t attachment without supervision. Always turn the appliance off, when you leave the room. Pull the plug cut of the socket. Close supervision is necessary when any appliance is used near children.
6. Keep the attachment away from children. The device should be used and stored out of the reach of children.
7. Avoid contacting moving parts, Keep fingers out of discharge opening.
8. Please place the appliance on a stable and flat table. It will cause injury if it is placed on uneven level.
9. Keep hands, utensils or other objects away from the pasta roller and cutters, or moving parts while it is in operation.
10. Do not touch any moving parts during the use.
11. Do not use the appliance if it is damaged.
12. Do not let the power cord fall from the edge of the table, the power cord winding around the object or fuselage will make the product fall and cause damaged.
13. Do not remove food until the stand mixer is OFF and the cutters stops.
14. Do not attempt to repair the device yourself, since you will be exposed to hazardous live components or other hazards .Repairs should only be carried out in a qualified workshop.
15. No liability is accepted for damage due to improper use or the failure to observe our operating instructions / safety notes.

Read All Instructions

PARTS AND FEATURES

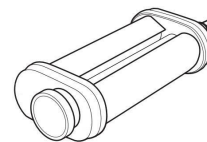

Pasta Roller

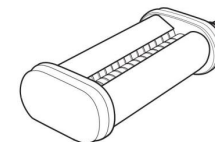

Fettuccine Cutter (optional)

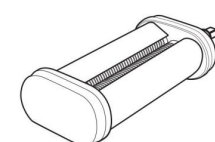

Spaghetti Cutter (optional)

FUNCTION

Attachment	Speed	Noodle width	Suggested Uses
PASTA ROLLER	1	Up to 140mm	See roller settings chart
FETTUCCINE CUTTER	4	6.5mm	Egg noddles Fettuccine
SPAGHETTI CUTTER	4	2mm	Spaghetti Thin fettuccine Linguine fini

Roller settings chart

Attachment	Roller setting	Suggested Use
Pasta roller	1 or 2	Kneading and thinning dough
	4	Egg noddles
	4 or 5	Spaghetti, Fettuccine, Ravioli, lasagna noddles
	6 or 7	Thin fettuccine, Tortellini, linguini fini

BEFORE FIRST USE

To avoid damage, do not wash or immerse the attachment in water or other liquid. Do not wash in dishwasher. **Note:** These attachment are designed for making pasta dough only. Do not cut or roll anything other than pasta to avoid damaging your pasta roller.

1. Assembling

△ ATTENTION! Before assembling, turn the stand mixer off and unplug first.

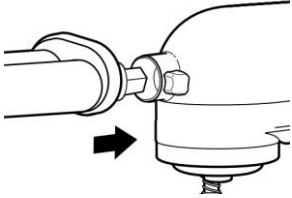
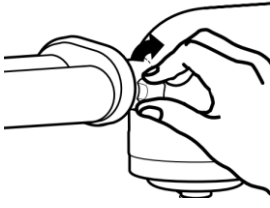
	
<p>1. Insert the attachment shaft housing into the hub, making certain the power shaft fits into the square of hub socket. If necessary, make the pin on attachment housing fits into the notch of the hub rim when in proper position.</p>	<p>2. Tighten the attachment hub knob until the attachment is completely secured to the mixer.</p>

2. Using

△ WARNING! When using the pasta roller and the cutters, Do not wear ties, scarves, loose clothing or long necklaces; gather long hair with a clasp.

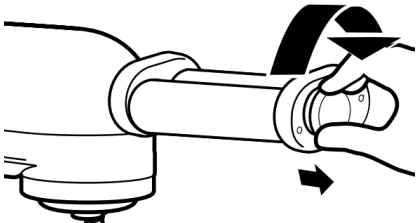
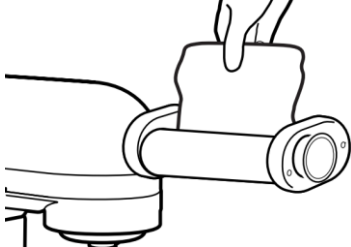
	
<p>1. Cut dough into sections that fit in the pasta roller. 2. Pull the pasta roller adjustment knob straight out and turn to setting 1. Release the knob, making certain the pin on the pasta roller housing engages the opening on the back of the adjustment knob, allowing the knob to fit flush against the roller housing.</p>	<p>3. Turn to speed 2. Feed flattened dough into rollers to knead. Fold dough in half and roll again. Repeat until dough is smooth and pliable and covers the width of the roller. Lightly dust pasta with flour while rolling and cutting to aid in drying and separation.</p>

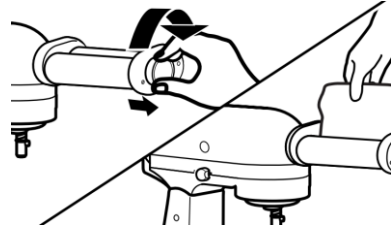
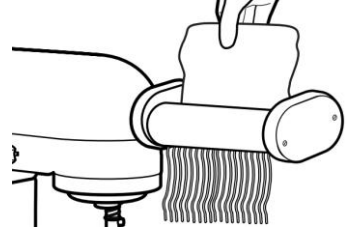
	
<p>4. Feed dough through rollers to further flatten the sheet of dough. Charge the roller to setting 3, and repeat the rolling process. Continue to increase roller setting until desired thickness is reached. Do not fold the dough during this step.</p>	<p>5. To make noodles, exchange the pasta roller for the cutter of your choice. Feed the flattened sheets of dough through the cutter. See the "Function chart" to determine the correct thickness for each type of pasta.</p>

CLEANING AND MAINTENANCE

△ WARNING!

Before cleaning, please ensure that the Switch knob is at the "OFF" position and the plug has been disconnected from the socket, otherwise it may cause an electric shock or injury risk.

Never clean the pasta roller and cutters attachment when it is assembled in the stand mixer. It could result in a seriously injured.

△ ATTENTION!

Do not use metal objects to clean out the pasta roller and cutters.

Do not wash the attachment in the dishwasher, or immerse in water or other liquids.

The attachment must be hand washed.

△ Note:

* After cutting pasta, let the roller and cutters air dry for one hour, then remove and dried dough using the cleaning brush. If dried dough is difficult to remove, try tapping the attachment with your hand. Use a toothpick if necessary.

* After cleaning out all remaining dried dough, polish the pasta roller and cutters with a soft, dry cloth and store in a dry place at room temperature.

* To maintain properly we recommend using a light mineral oil to lubricate the gears. Add a drop of the mineral oil to each of the four corners of the pasta roller and cutters.

Remark: This pasta roller and cutters attachment is designed for KitchenAid Stand Mixers, but not a KitchenAid brand, KitchenAid is registered trademarks of their respective owners and are not endorsing, sponsoring or associated with us.

Thank you for your reading and support. We wish you a happy life and good health.

Sincerely hope we can continuously provide you with better products and services.

.MADE IN CHINA