

WARRANTY

We strive to offer high-quality products, and we also try our best to satisfy each and every customer that orders from us with product or service as needed.

Each customer must provide a record of their order such as the order number, or item receipt for any items that are out of the warranty period you may also still receive replacement parts by purchasing them with our company if they are available.

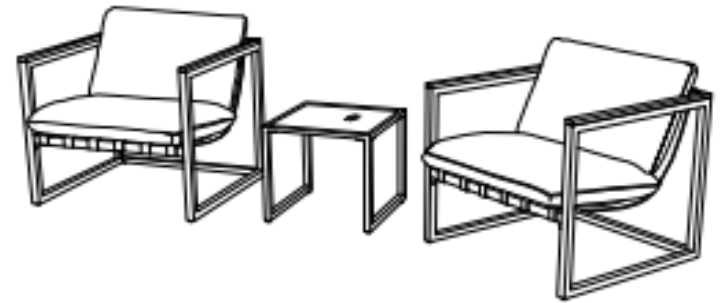

NOTE:

This brochure contains IMPORTANT safety info. Please read and keep for future reference.

MAINTAINANCE AND WARNING







- Keep furniture away from heat and fire.
- Keep furniture away from sharp objects.
- Do not clean furniture with harsh cleansers or polish. Do not use detergents, Solvents, abrasives, spray packs or leather cleaner. Use non-color mild soap with warm water clean spills(Mix 1:10 soap to water)
- Do not place furniture under direct sunlight, material will possibly fade over time.
- Do not jump or strike on the furniture.
- Do not write on furniture without a padded barrier to protect the surface.
- Not for commercial use, For residential use only.



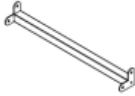

Weight Limitation

Chair: 250LBS
Table: 90LBS

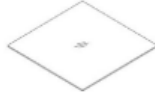
PARTS LIST

A		2* Left Armrest
B		2* Right Armrest
C		2* Seat Part
D		2* Seat Tube
E		2* Cushion
F		1* Table Top Frame
G		2* Table Foot
H		1* Glass

HARDWARE and TOOL LIST

AA	 M6*20	32
BB	 06	32
CC	 S=1	1

Be sure to check all packing material fit the packing list. Carefully for small parts, which may have come loose inside the carton during shipment.

ASSEMBLY INSTRUCTIONS

1.

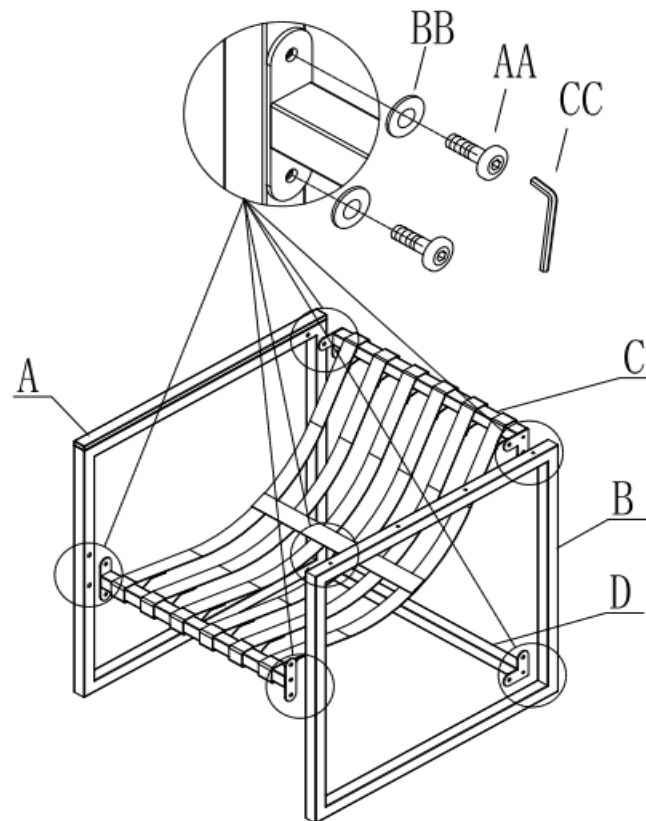

Step 1: Assemble armrest parts A and B to seat parts C and D with screws. Please do not lock the screws when assembling. Lock all screws when you complete step 1.

2.

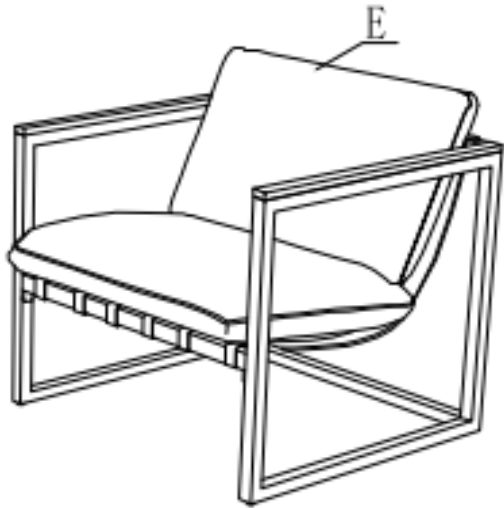

Step 2: Place cushion E on the frame. And fix the cushion tie to the chair frame

3.

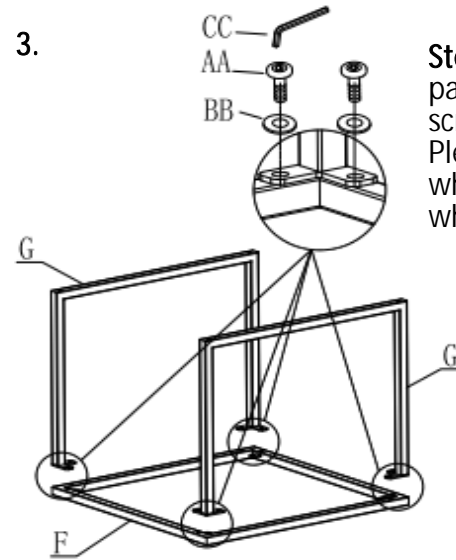

Step 3: Assemble the table foot part G to the table frame F with screws. Please do not lock the screws when assembling. Lock all screws when you complete step 3.

4.

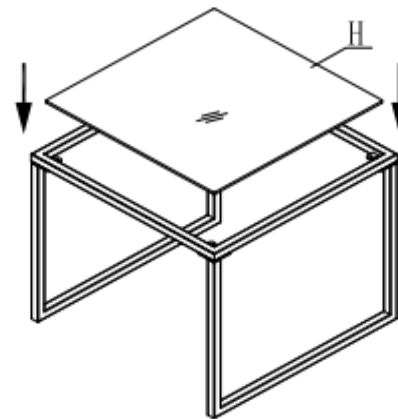

Step 4: Put glass H on the table top.