

HW-AM503007

CUSTOMER MANUAL

-V0.2

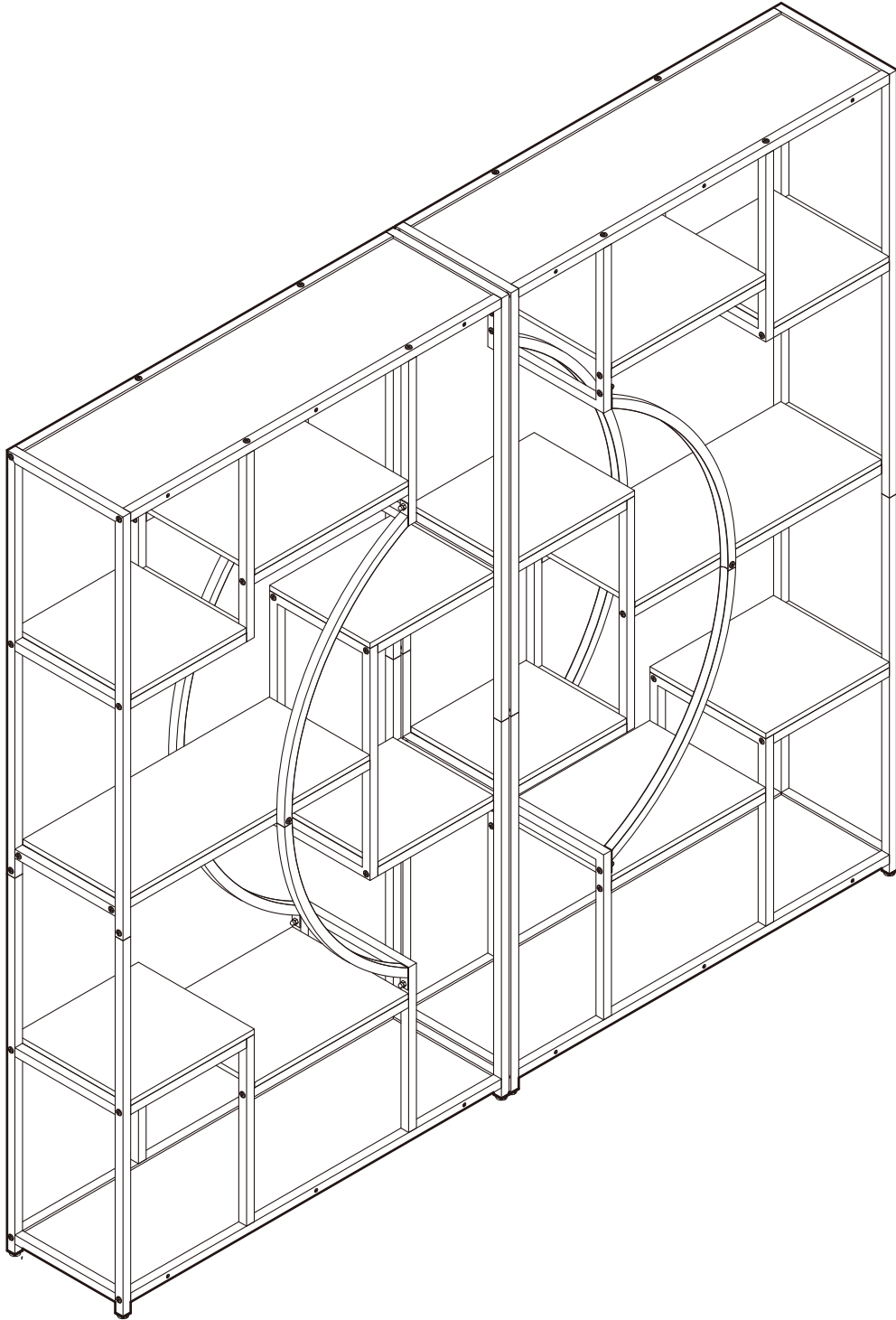

Contact us: Support@lghm.vip

ASSEMBLY STRUCTURE REFERENCE DIAGRAM

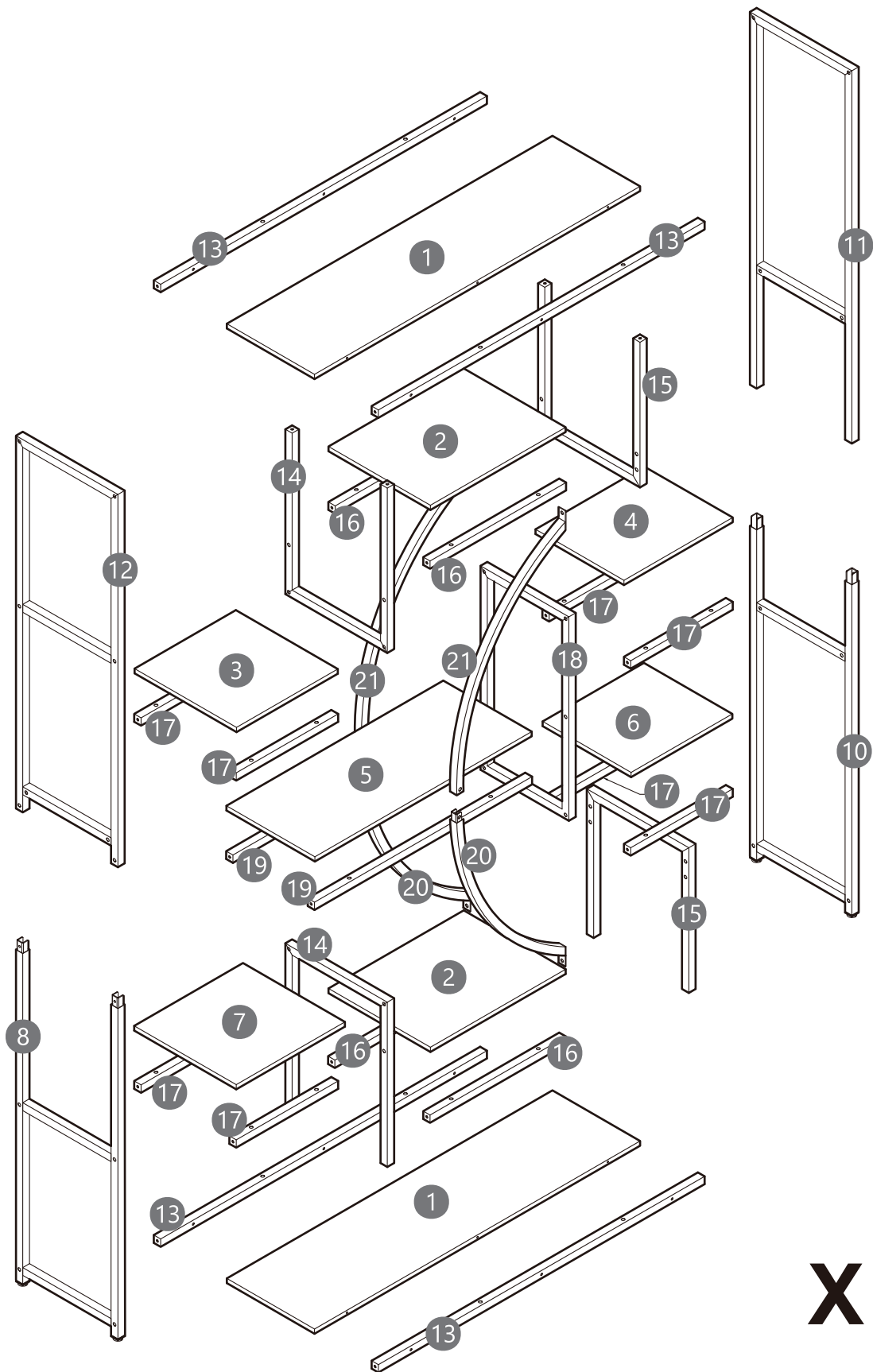

X 2

PACKAGE CONTENT

1

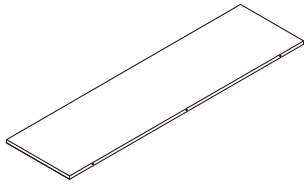

958 x 258mm
4 PCS

2

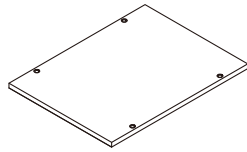

398 x 300mm
4 PCS

3

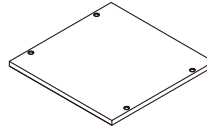

300 x 300mm
2 PCS

4

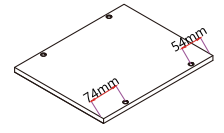

320 x 260mm
2 PCS

5

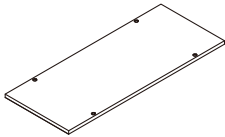

638 x 260mm
2 PCS

6

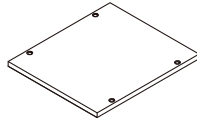

300 x 260mm
2 PCS

7

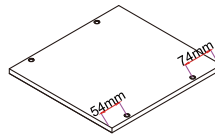

320 x 300mm
2 PCS

8

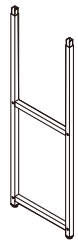

2 PCS

10

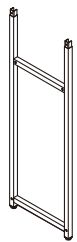

2 PCS

11

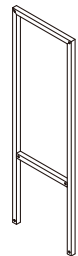

2 PCS

12

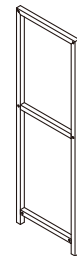

2 PCS

13

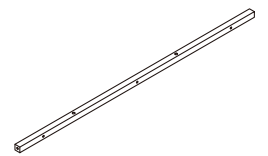

8 PCS

14

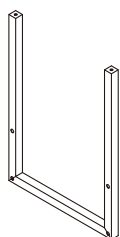

4 PCS

15

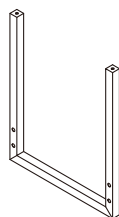

4 PCS

16

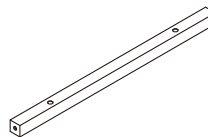

8 PCS

17

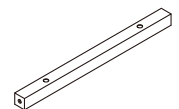

16 PCS

PACKAGE CONTENT

18

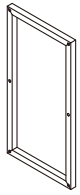

2 PCS

19

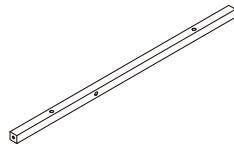

4 PCS

20



4 PCS

21

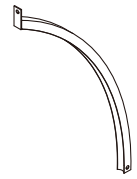

4 PCS

A

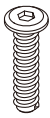

M6 x 28mm
X 64+1

B



M6 x 40mm
X 88+3

C



M6 x 50mm
X 4

D



M6 x 12mm
X 8+1

E



M5 x 40mm
X 24+1

F



M6
X 12+1

G

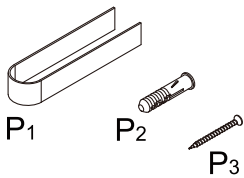

M5 x 55mm
X 4 Set

3#



X 1

4#



X 1



X 1

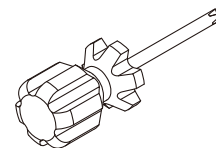



X 1

Step 1

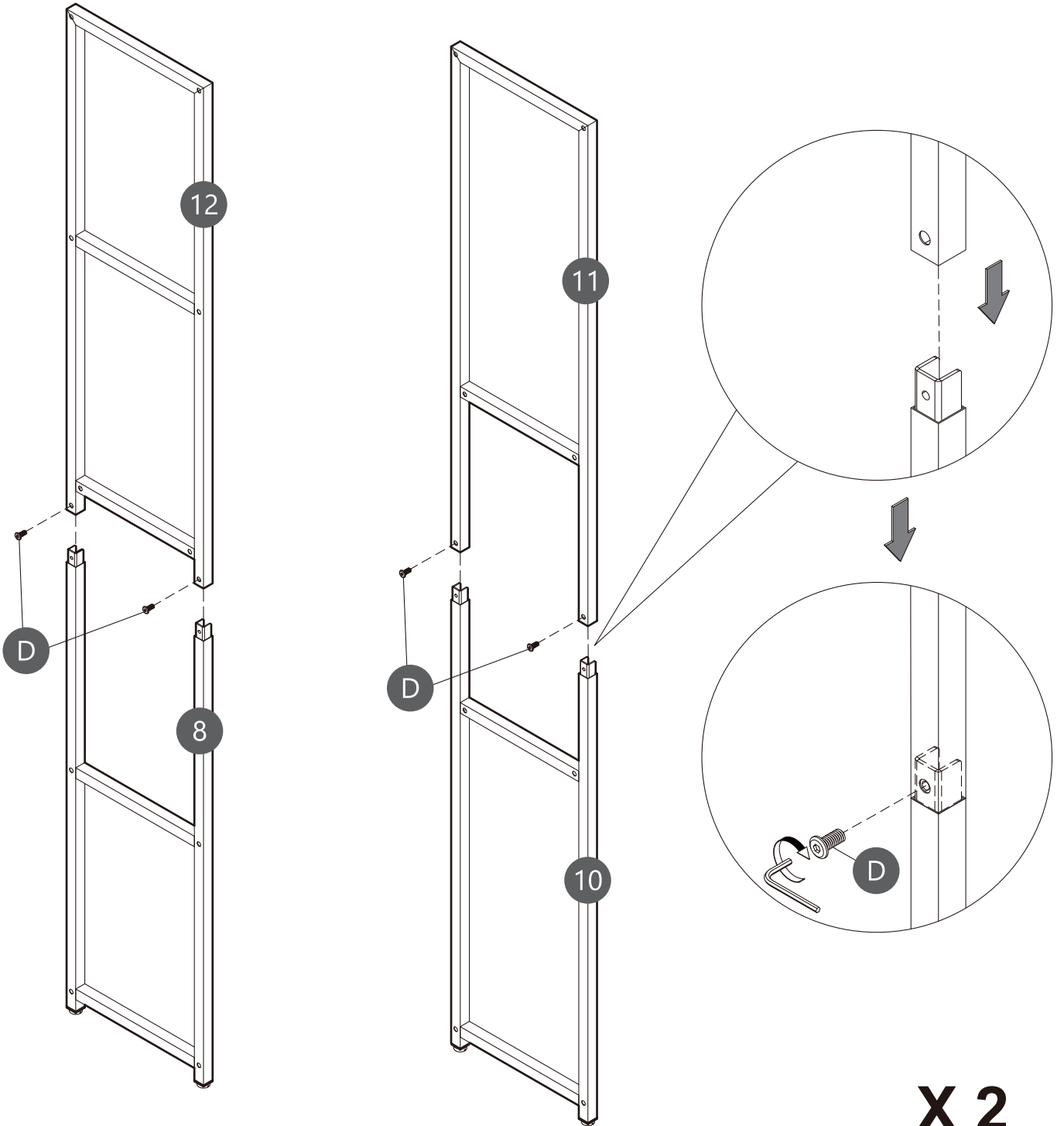
Screw D to lock (8)&(12),(10)&(11) as below shown.



X 2

D		× 8
4#		× 1

Step 2

Screw E to lock (13) on the (1) as below shown.

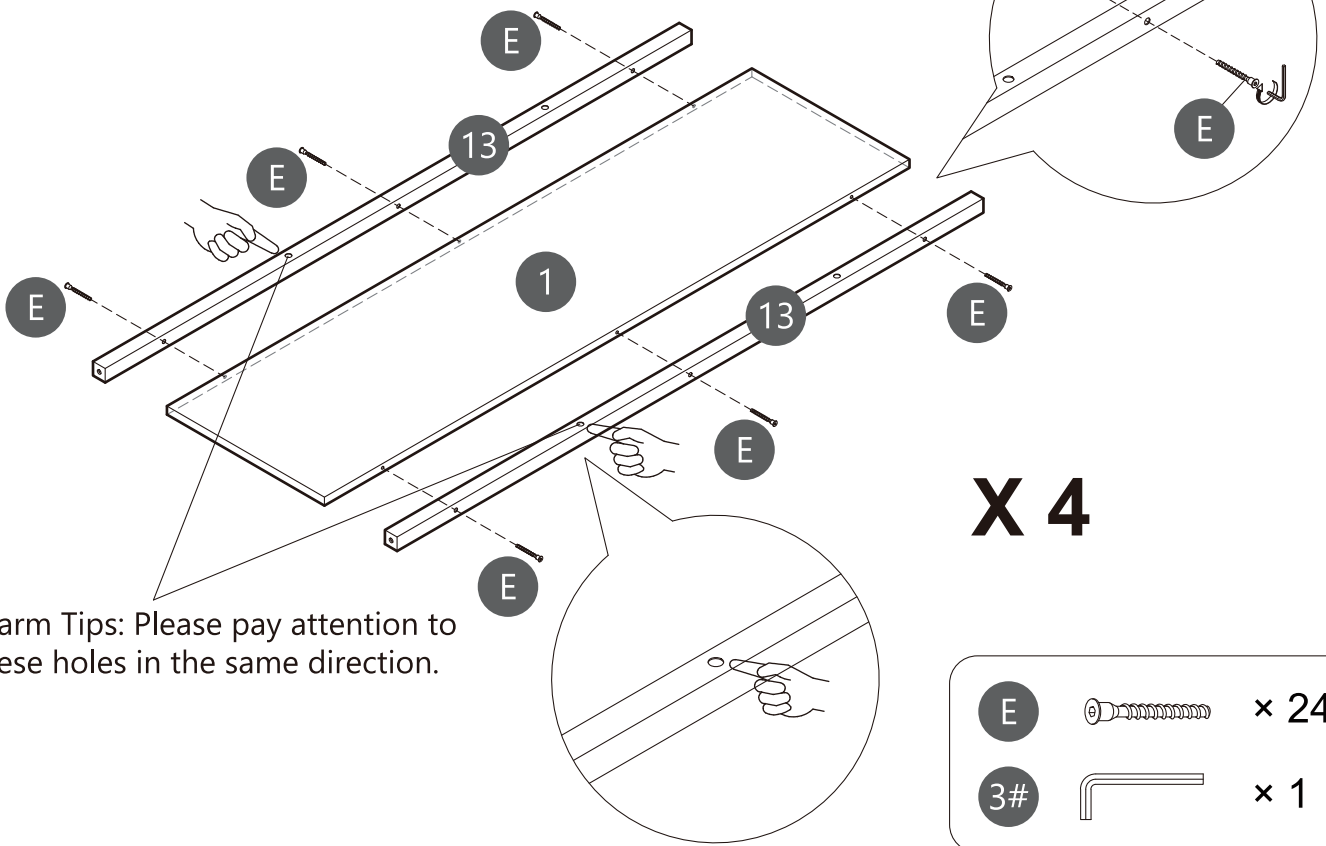

Step 3

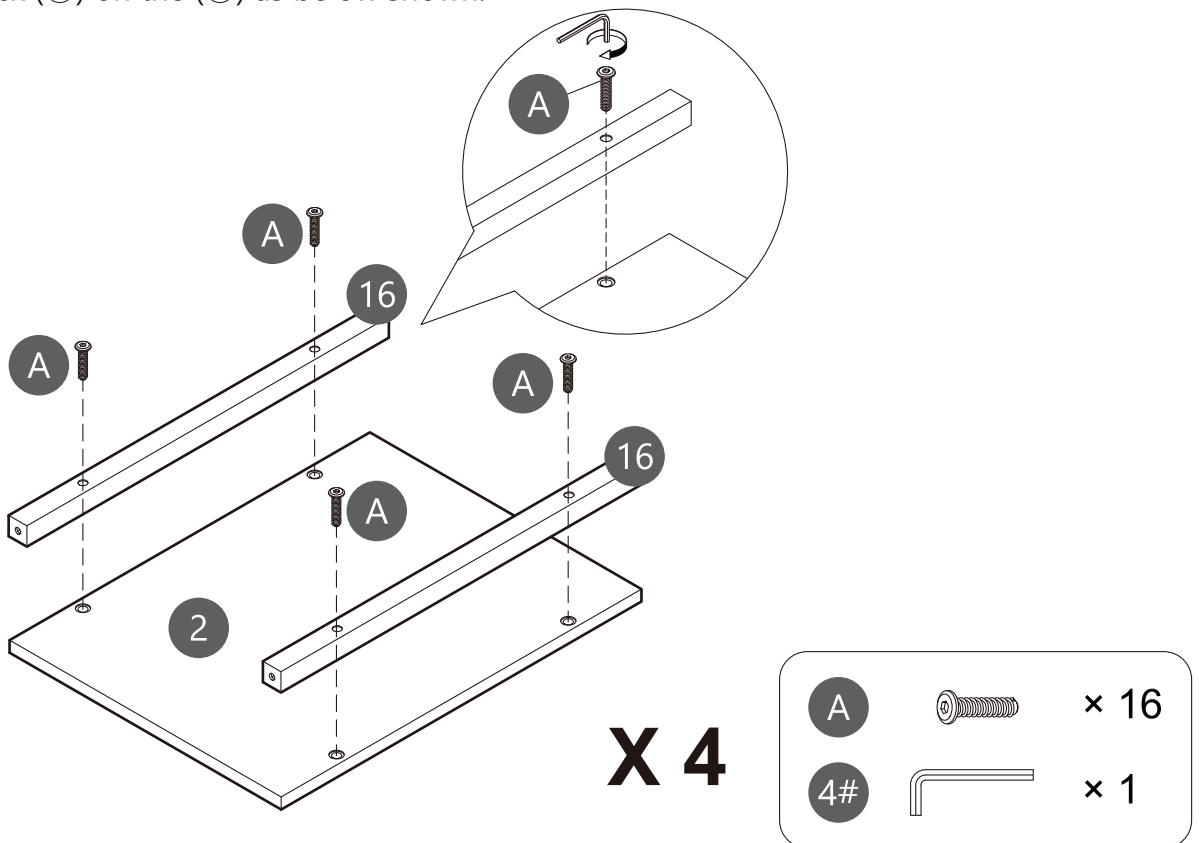

Screw (A) to lock (16) on the (2) as below shown.

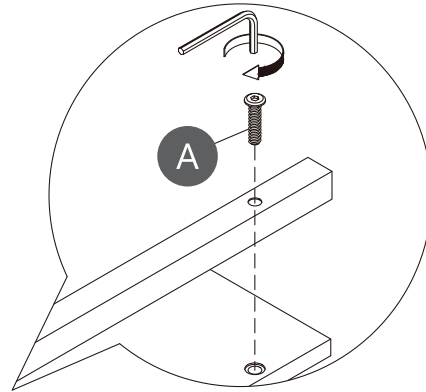
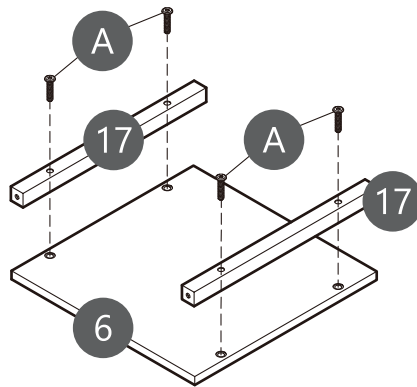
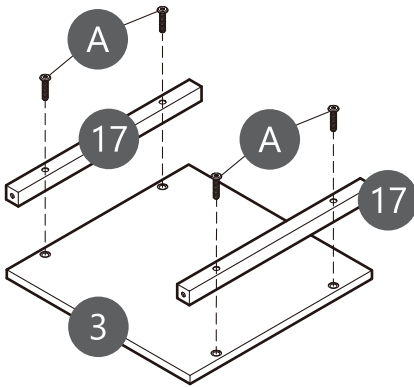

Step 4

Screw (A) to lock (17) on the (3) as below shown.
Screw (A) to lock (17) on the (6) as below shown.



A		× 16
4#		× 1



X 2

Step 5

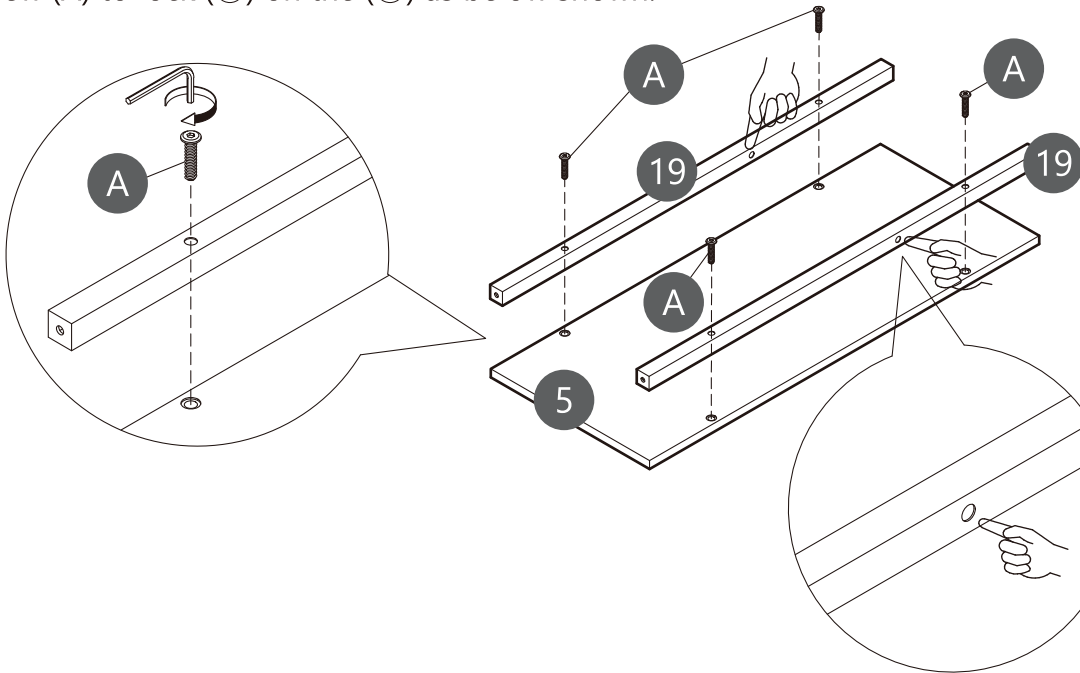
Screw (A) to lock (19) on the (5) as below shown.



X 2

A		× 8
4#		× 1

Step 6

Assemble Top Shelf.

Screw (B) to lock (14) on the (13) as below shown.

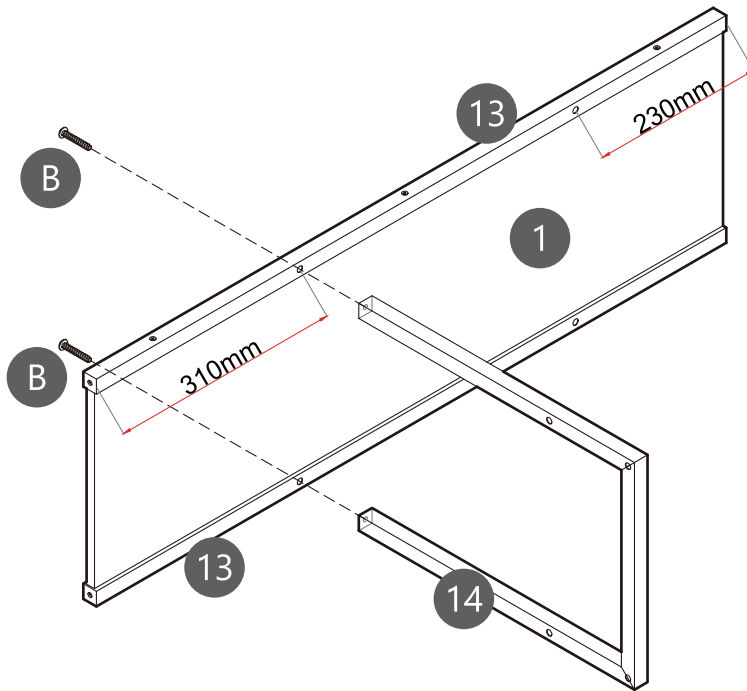

(B)		× 4
(4#)		× 1

Step 7

Screw (B) to lock (16) on the (14) as below shown.

Warm Tips: Please make sure that the metal support is under the board.

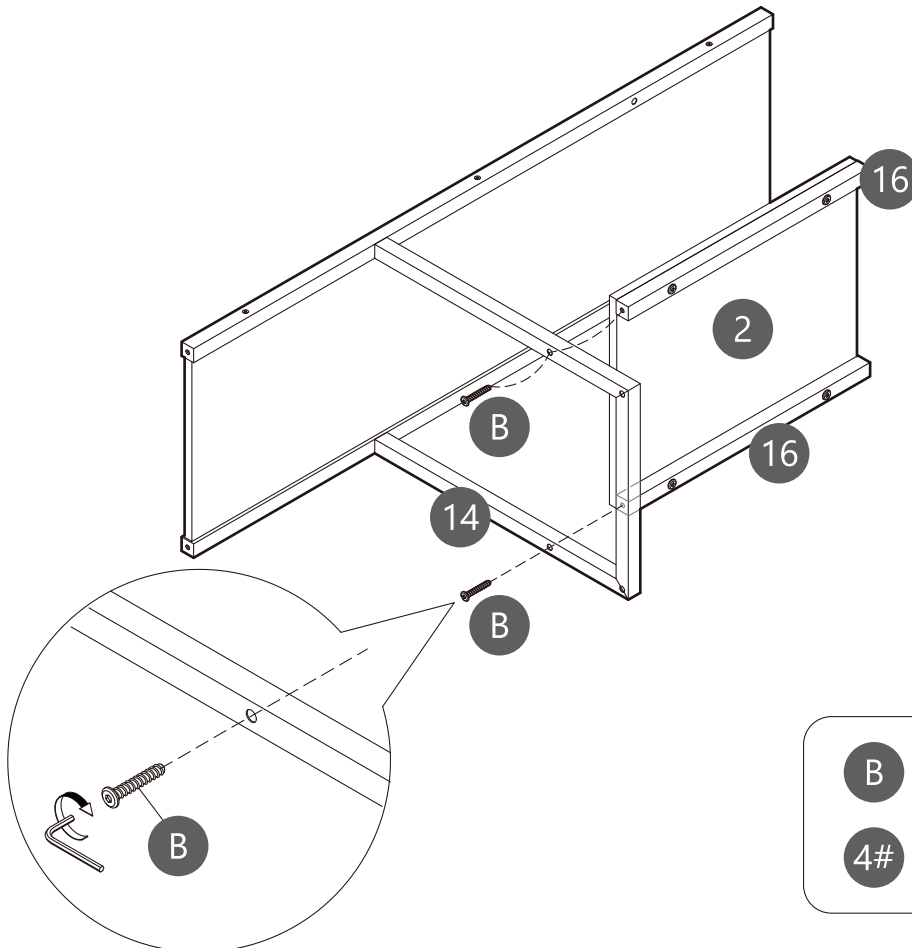



(B)		× 4
(4#)		× 1

Step 8

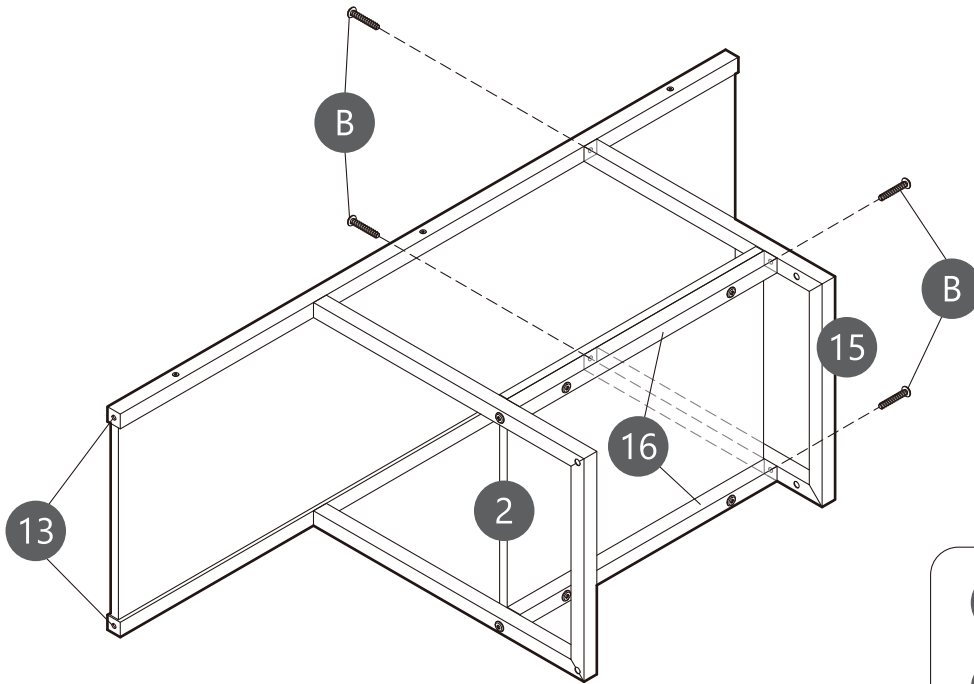
Screw (B) to lock (15) on the (13)&(16) as below shown.



X 2

B		× 8
4#		× 1



Step 9

Screw (B) to lock (17) on the (14) as below shown.

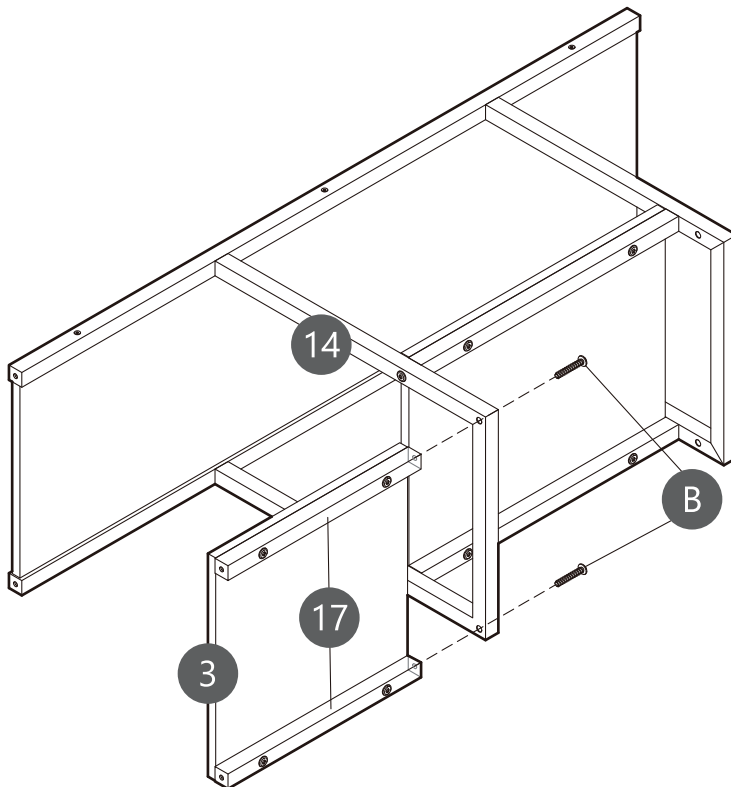
Warm Tips: Please make sure that the metal support is under the board.



X 2

B		× 4
4#		× 1

Step 10

Assemble Bottom Shelf.

Screw (B) to lock (14) on the (13) as below shown.

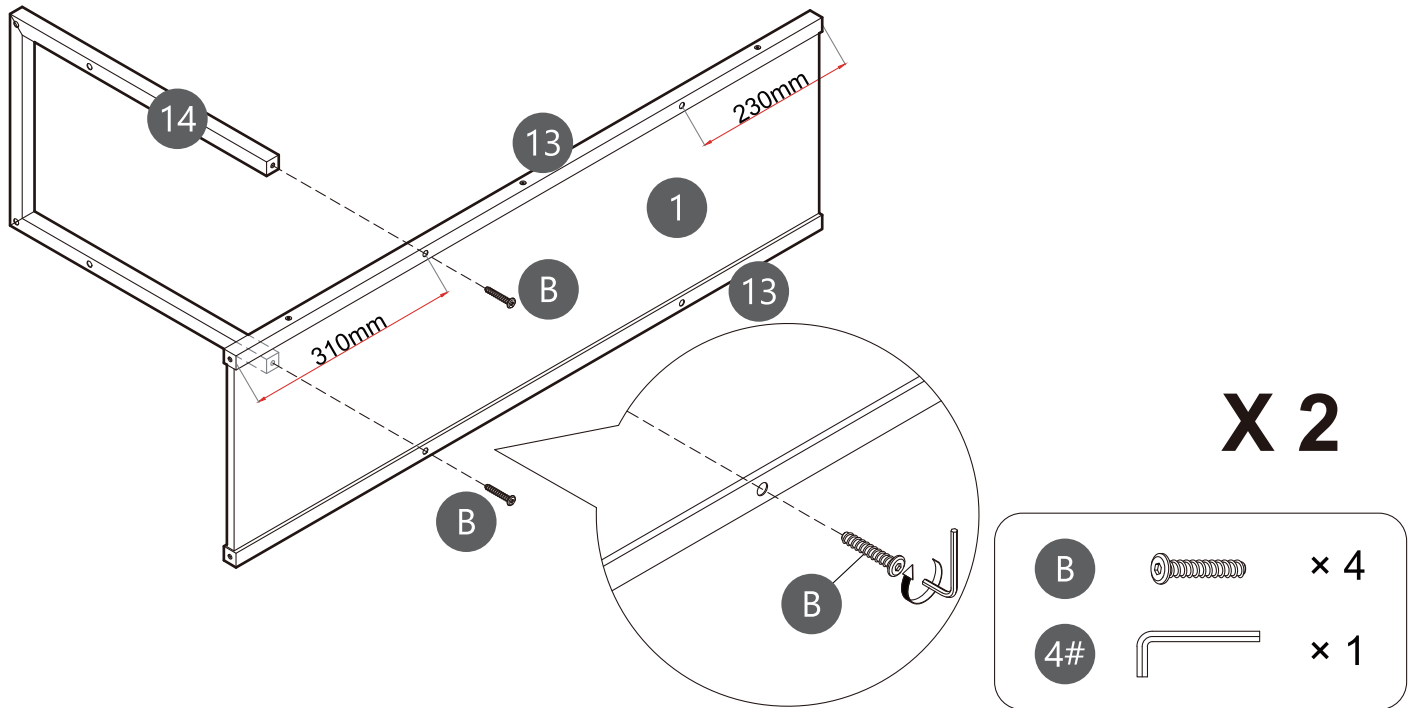

Step 11

Screw (B) to lock (16) on the (14) as below shown.

Warm Tips: Please make sure that the metal support is under the board.

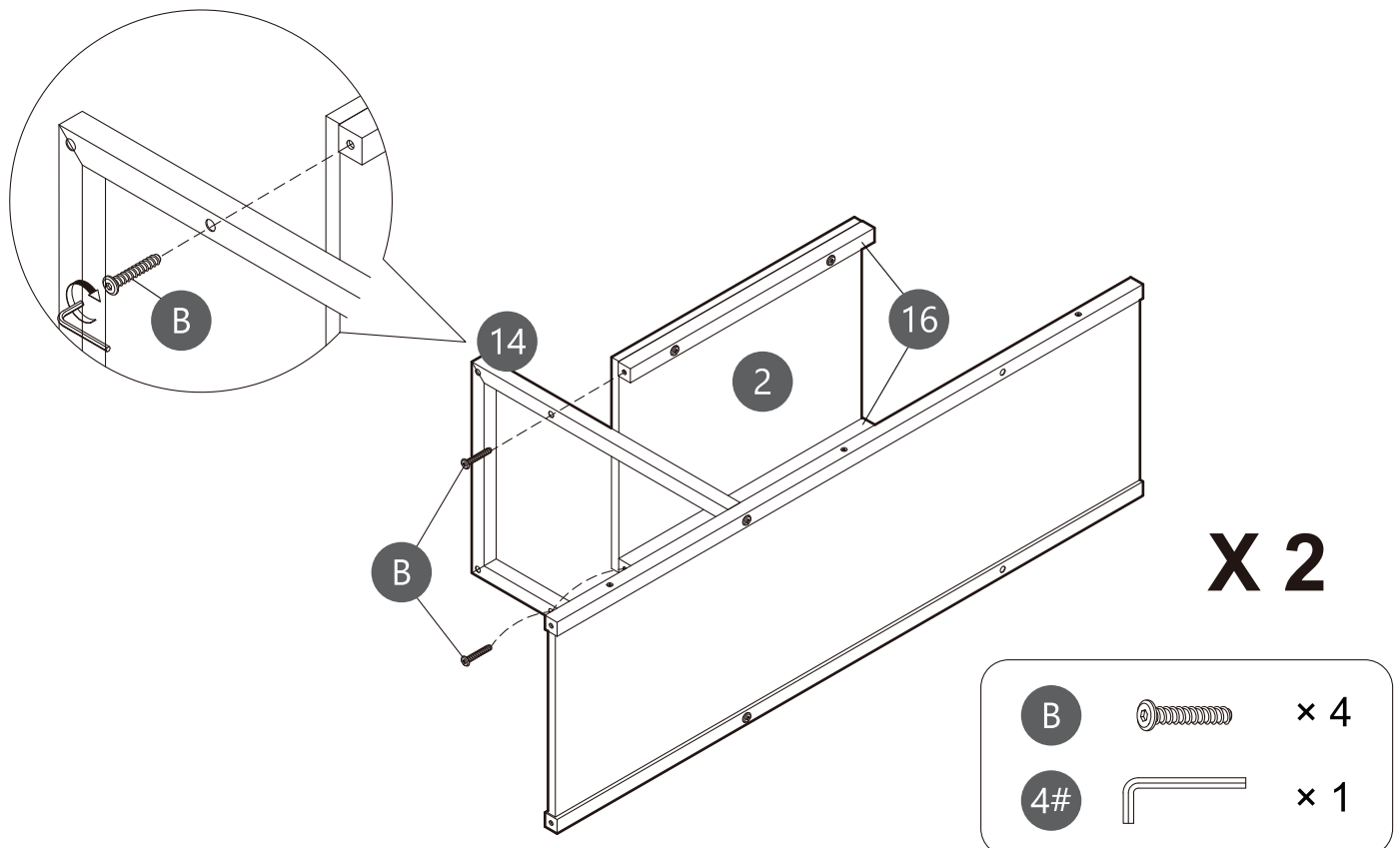

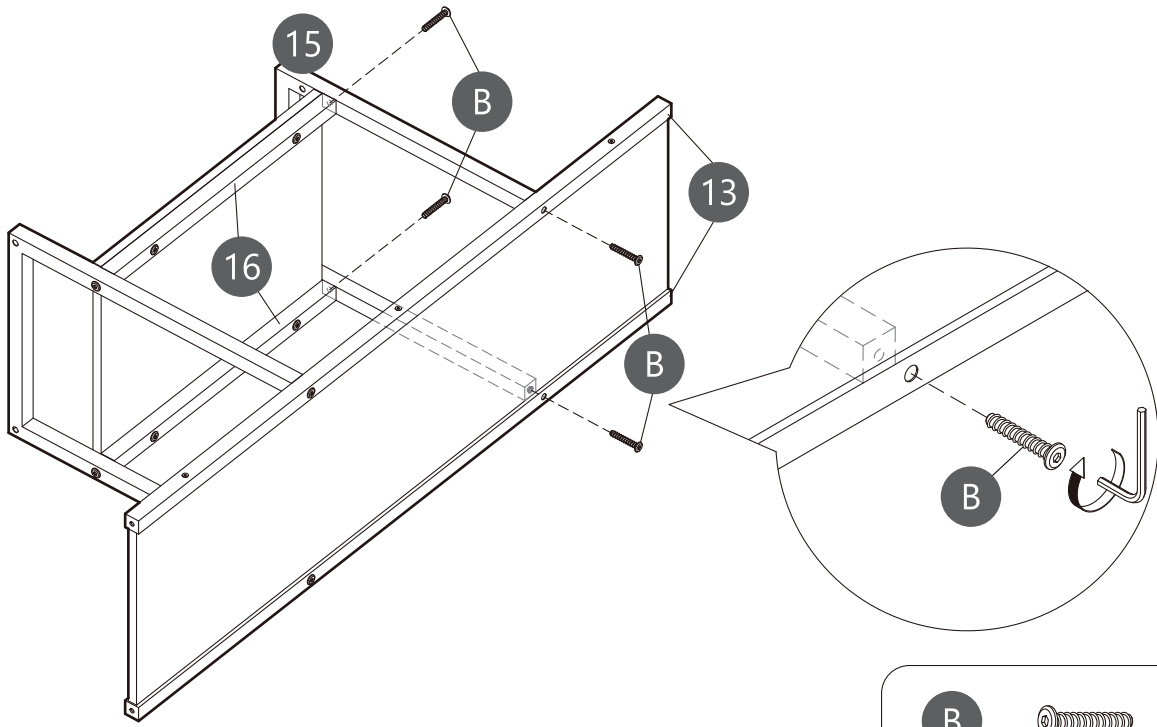

Step 12

Screw (B) to lock (15) on the (13)&(16) as below shown.



X 2



B		× 8
4#		× 1

Step 13

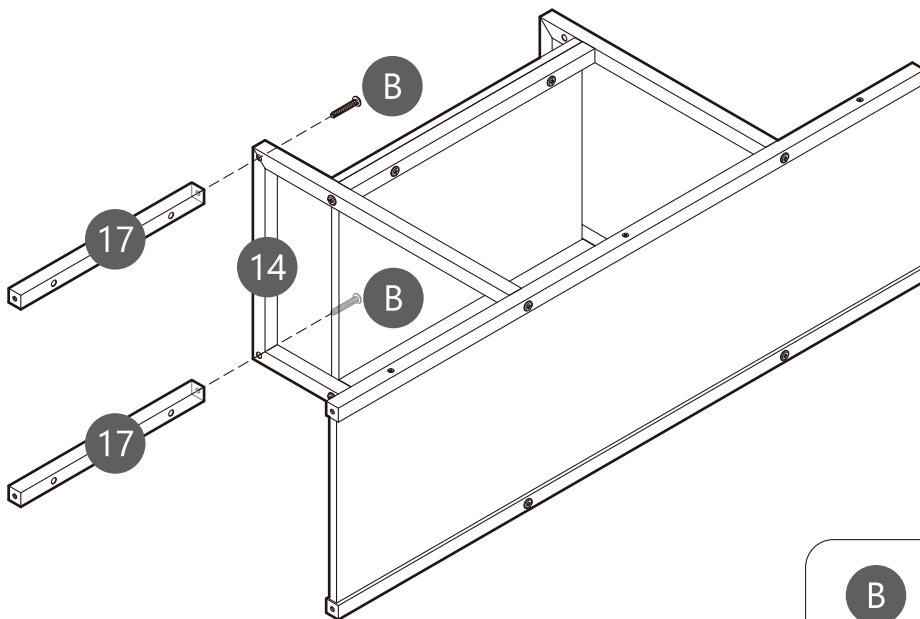
Screw (B) to lock (17) on the (14) as below shown.





X 2

B		× 4
4#		× 1

Step 14

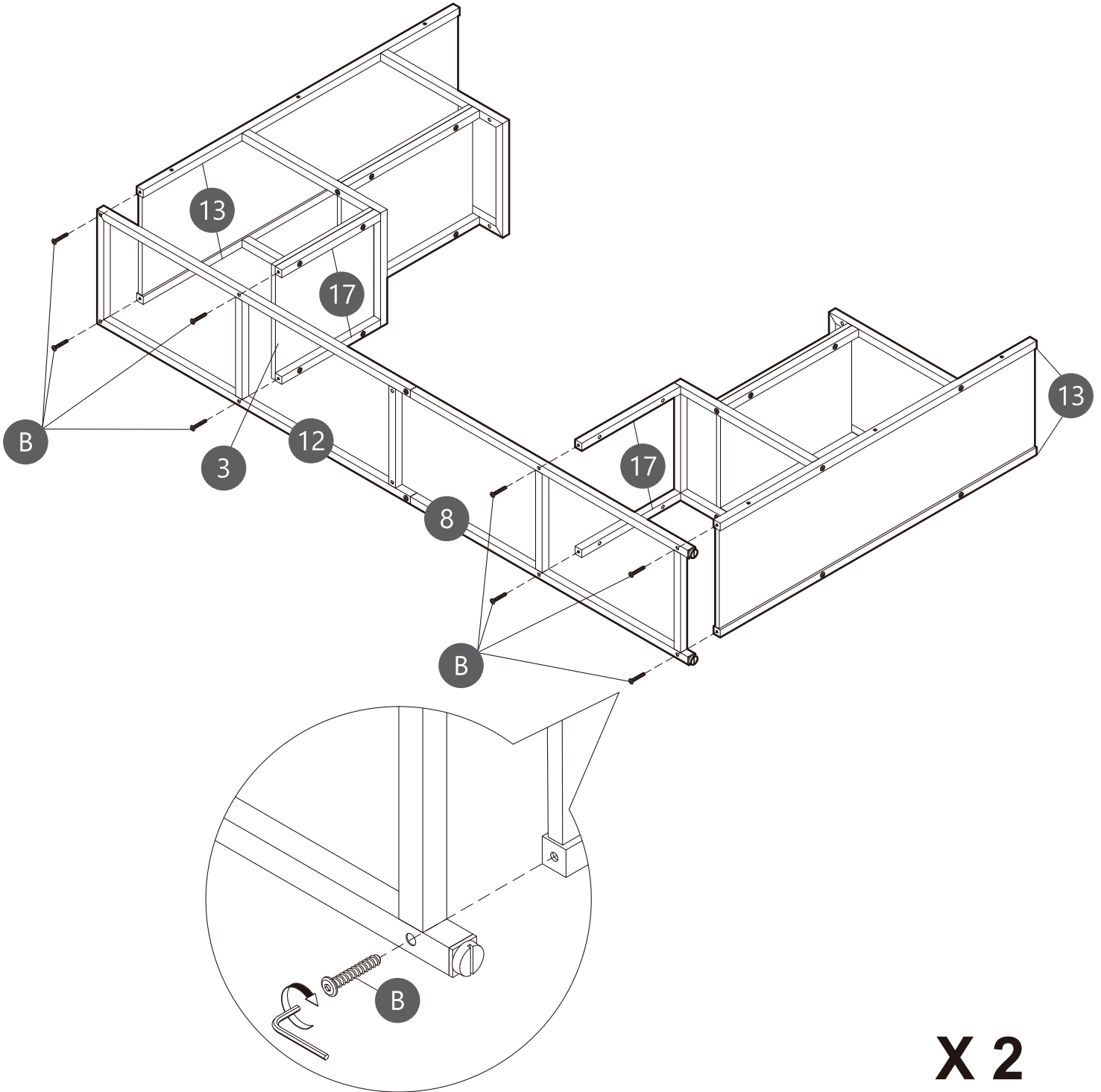
Assemble the top shelf and bottom shelf as below shown.
Lock screw (B) as below shown.





B		× 16
4#		× 1

Step 15

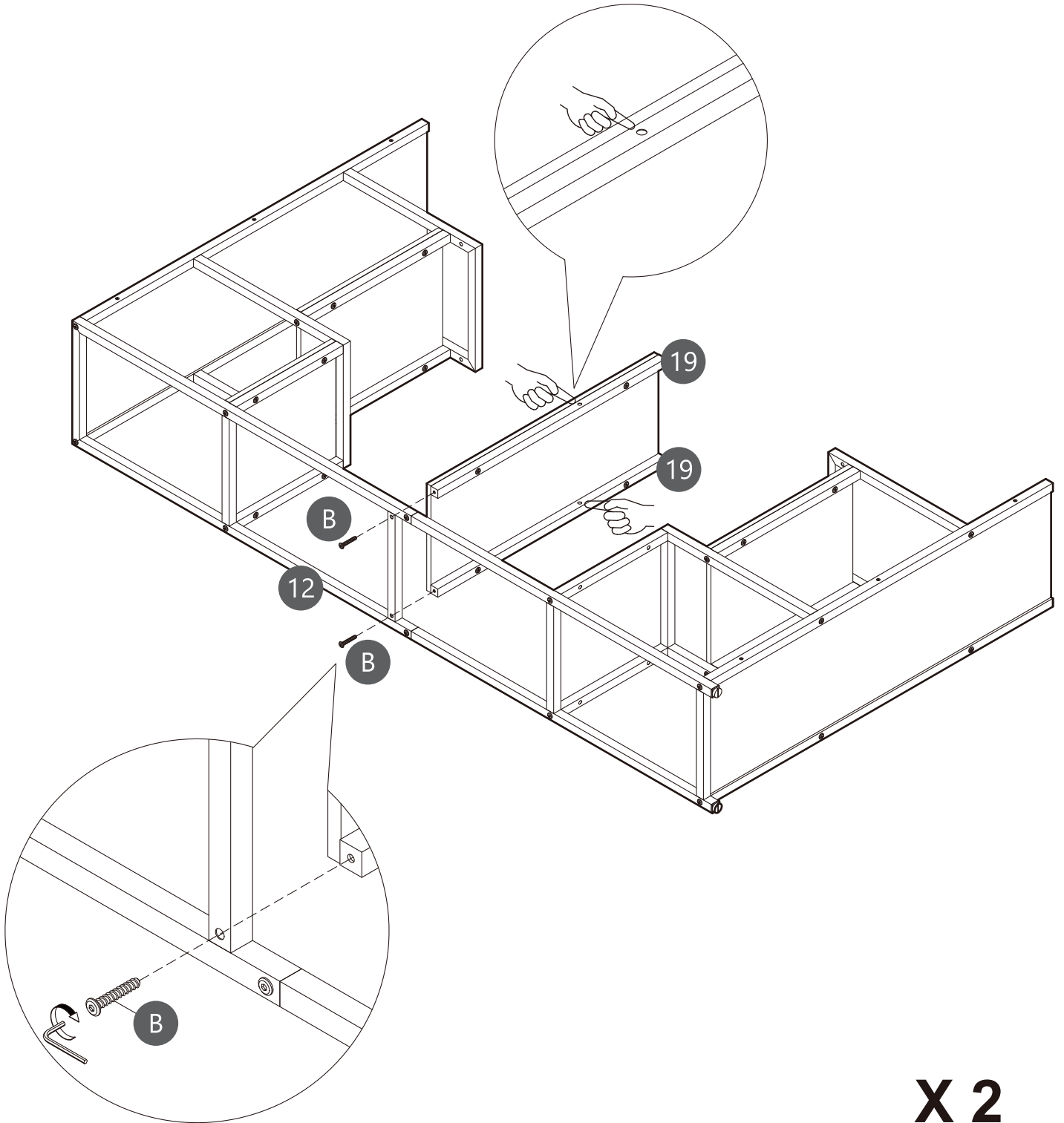
Screw (B) to lock (19) on the (12) as below shown.



X 2



B		× 4
4#		× 1

Step 16

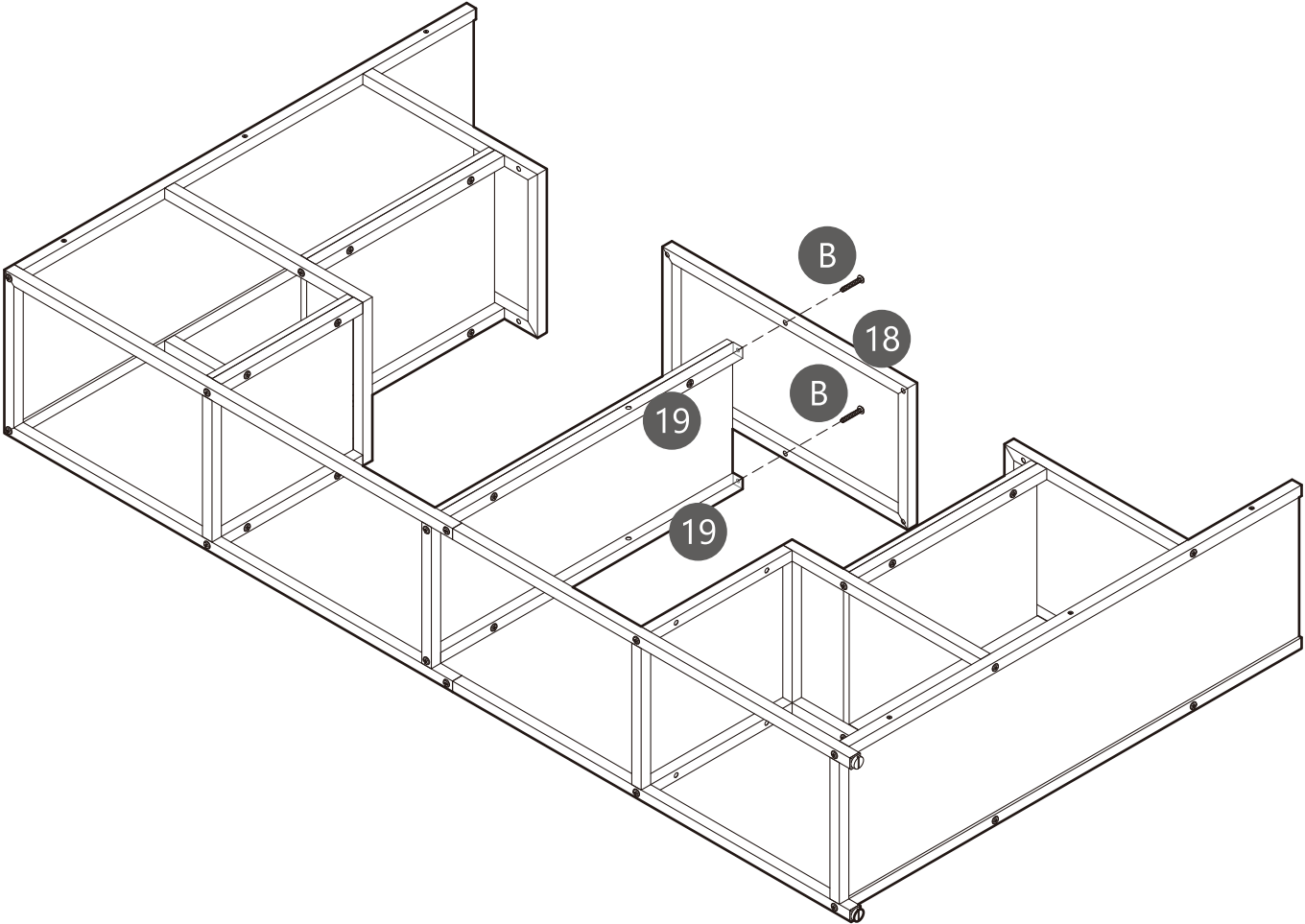
Screw (B) to lock (18) on the (19) as below shown.



X 2



B		× 4
4#		× 1

Step 17

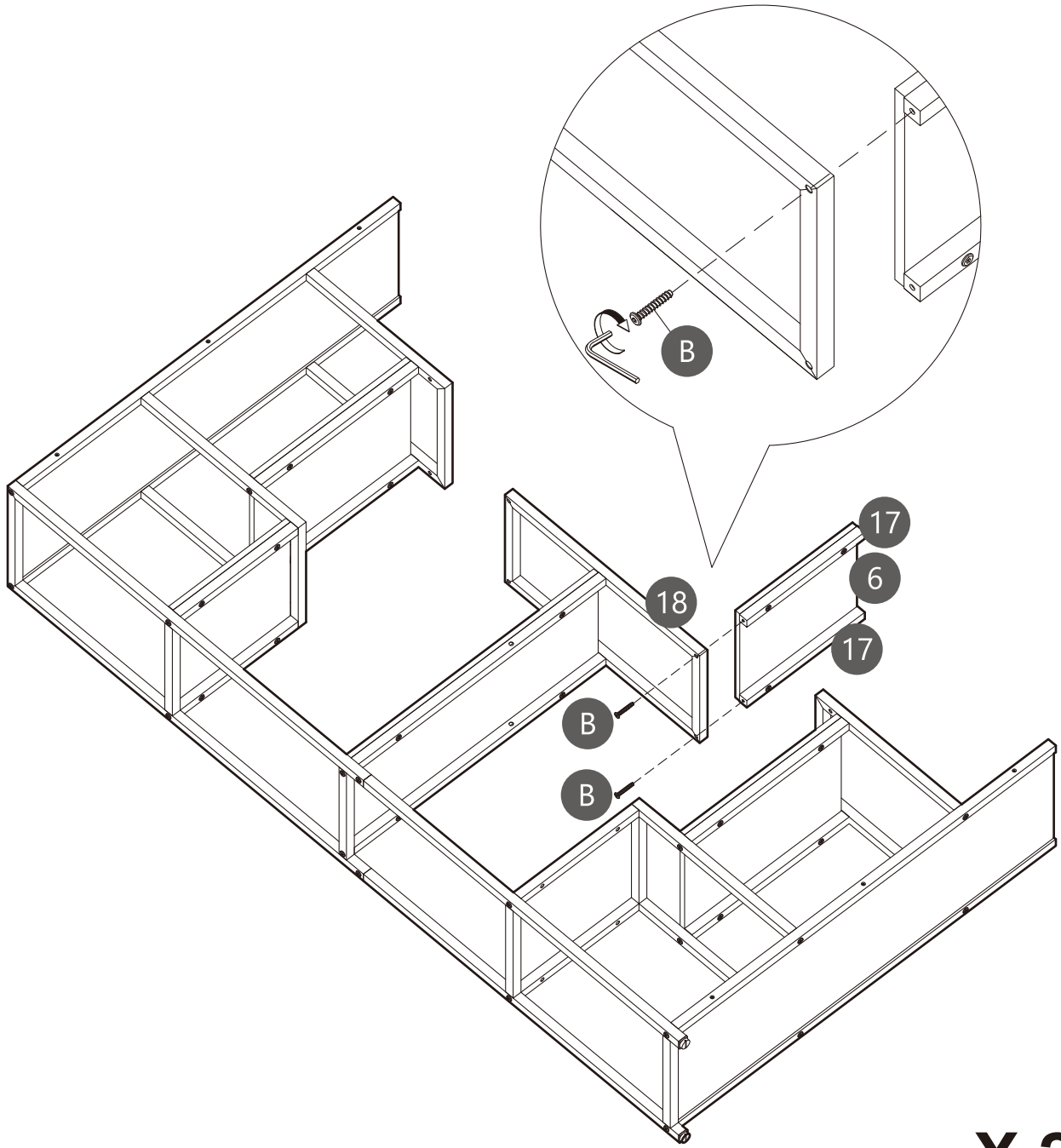
Screw (B) to lock (6)&(7) on the (18) as below shown.



X 2

B		× 4
4#		× 1

Step 18

Screw (B) to lock (17) on the (18) as below shown.

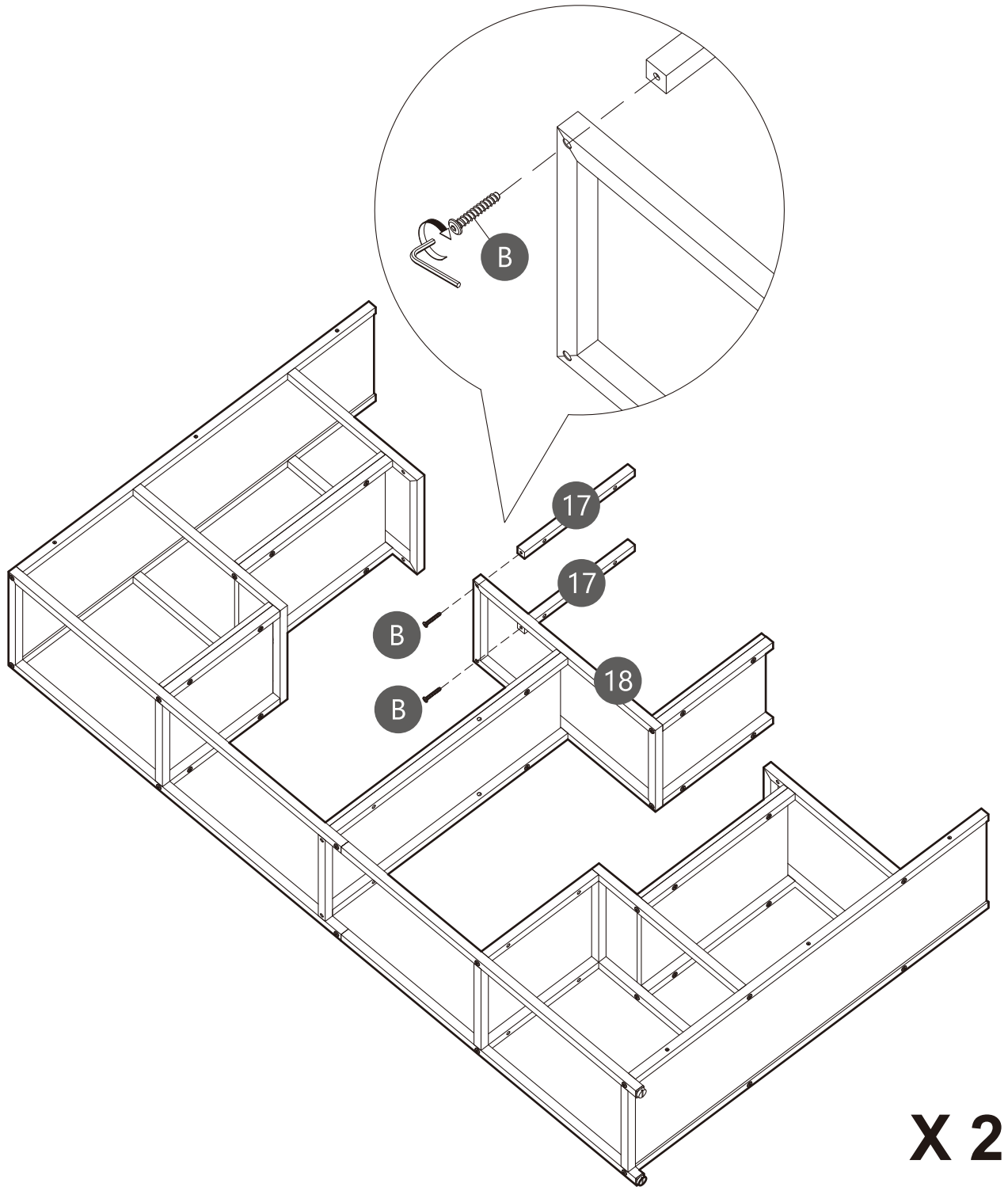

X 2



B		× 4
4#		× 1

Step 19

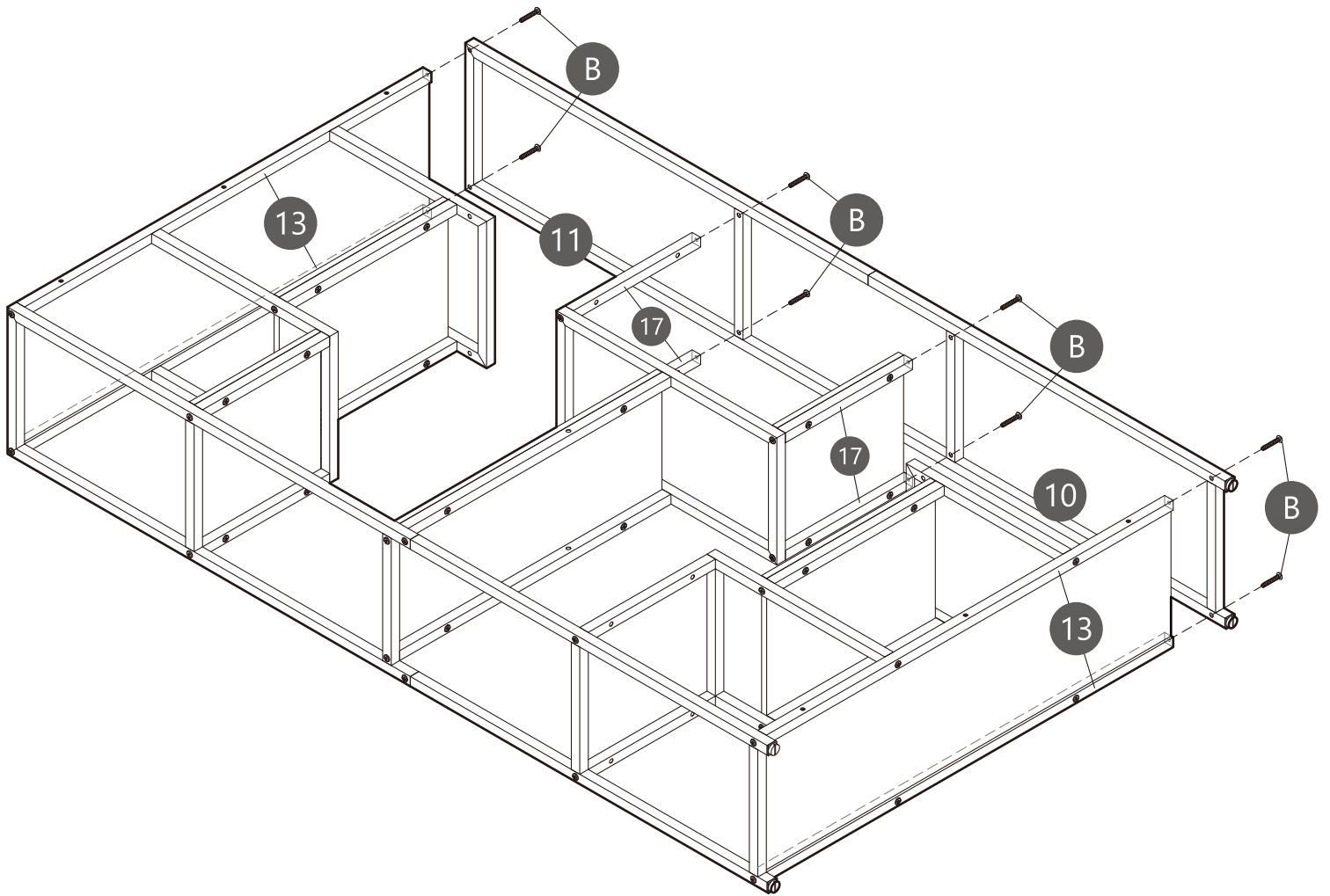
Assemble iron frame (10)&(11) as below shown.
Lock screw (B) as below shown.



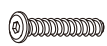

X 2

B		× 16
4#		× 1

Step 20

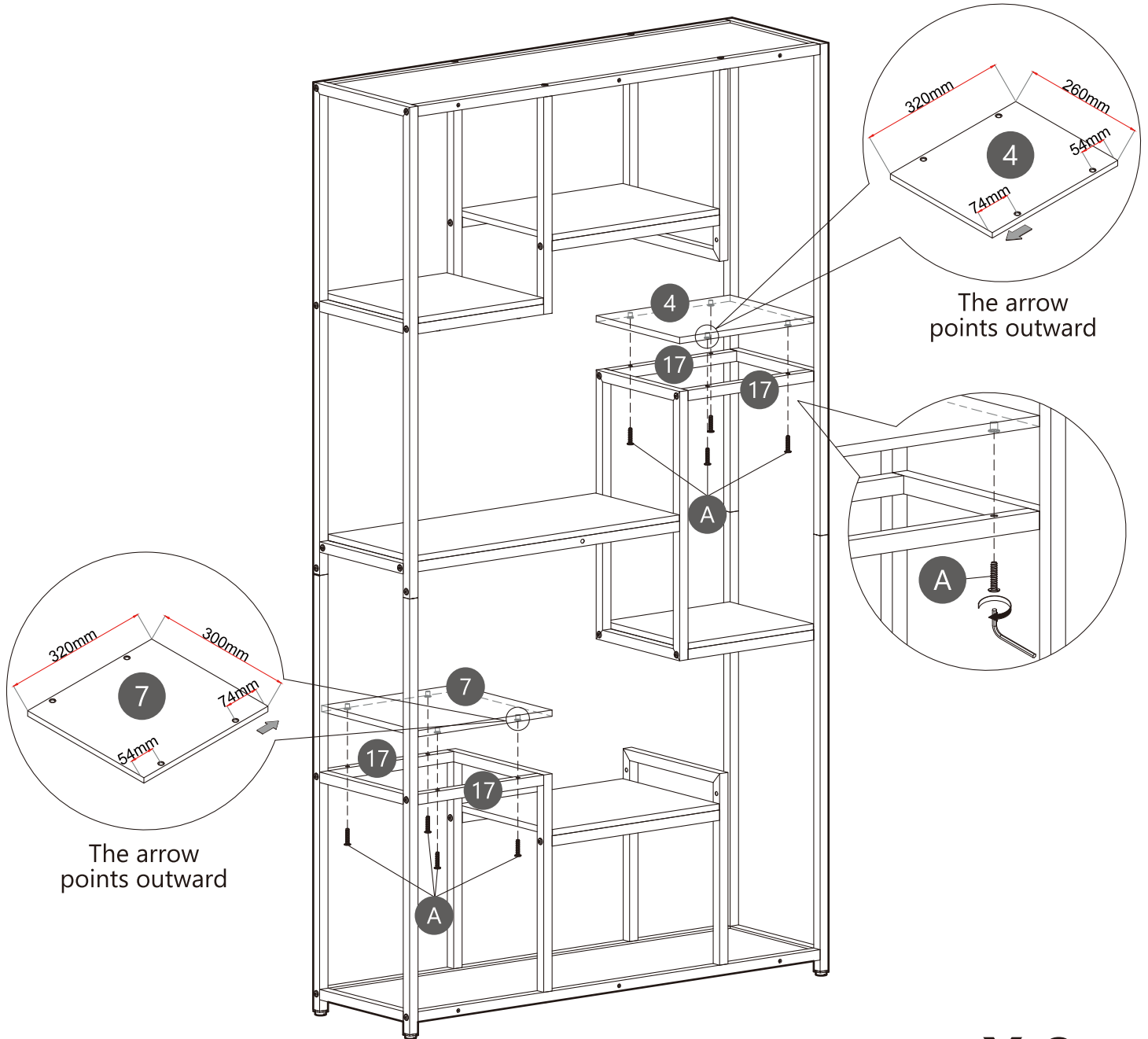
Put board(4) on the (17) as below shown.
Put board(7) on the (17) as below shown.
Lock screw (A) as below shown.





A		× 16
4#		× 1

Step 21

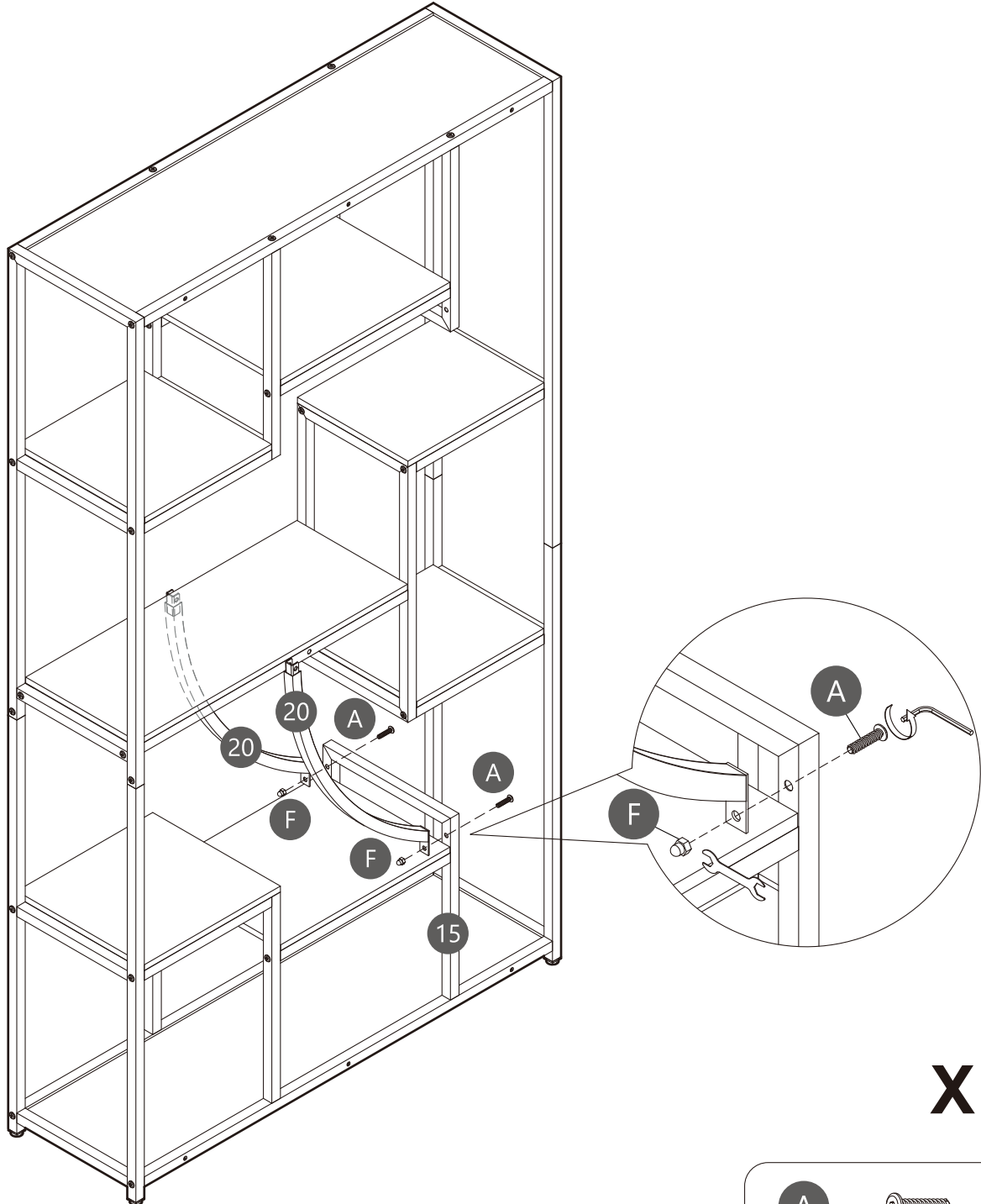
Screw (A) & (F) to lock (20) on the (15) as below shown.

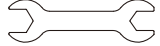

X 2

A		× 4
F		× 4
4#		× 1
		× 1

Step 22

Assemble (21) & (20) as below shown.

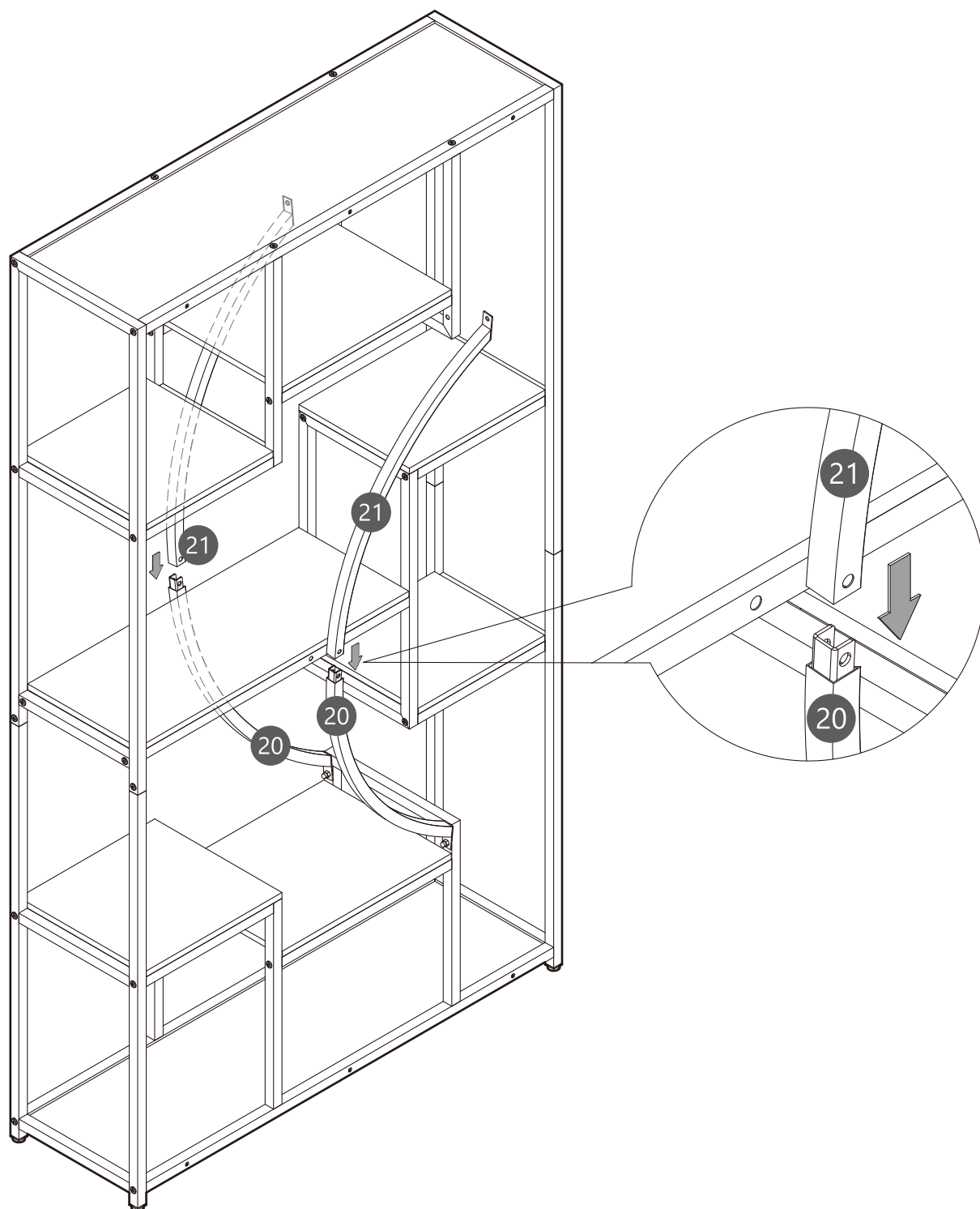



X 2

Step 23

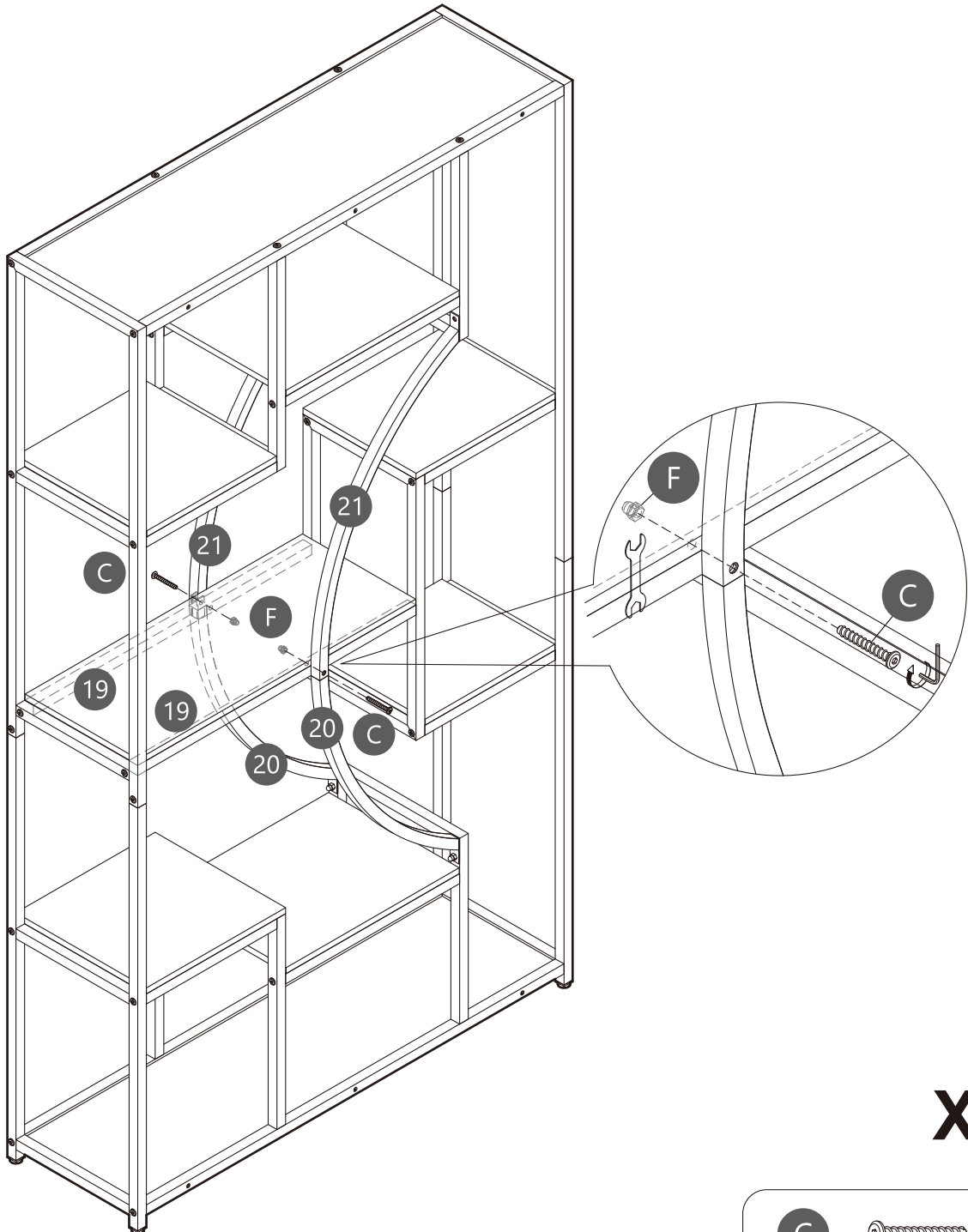
Screw (C) & (F) to lock (19)&(20)&(21) as below shown.

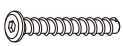

X 2

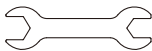

C		× 4
F		× 4
4#		× 1
		× 1

Step 24

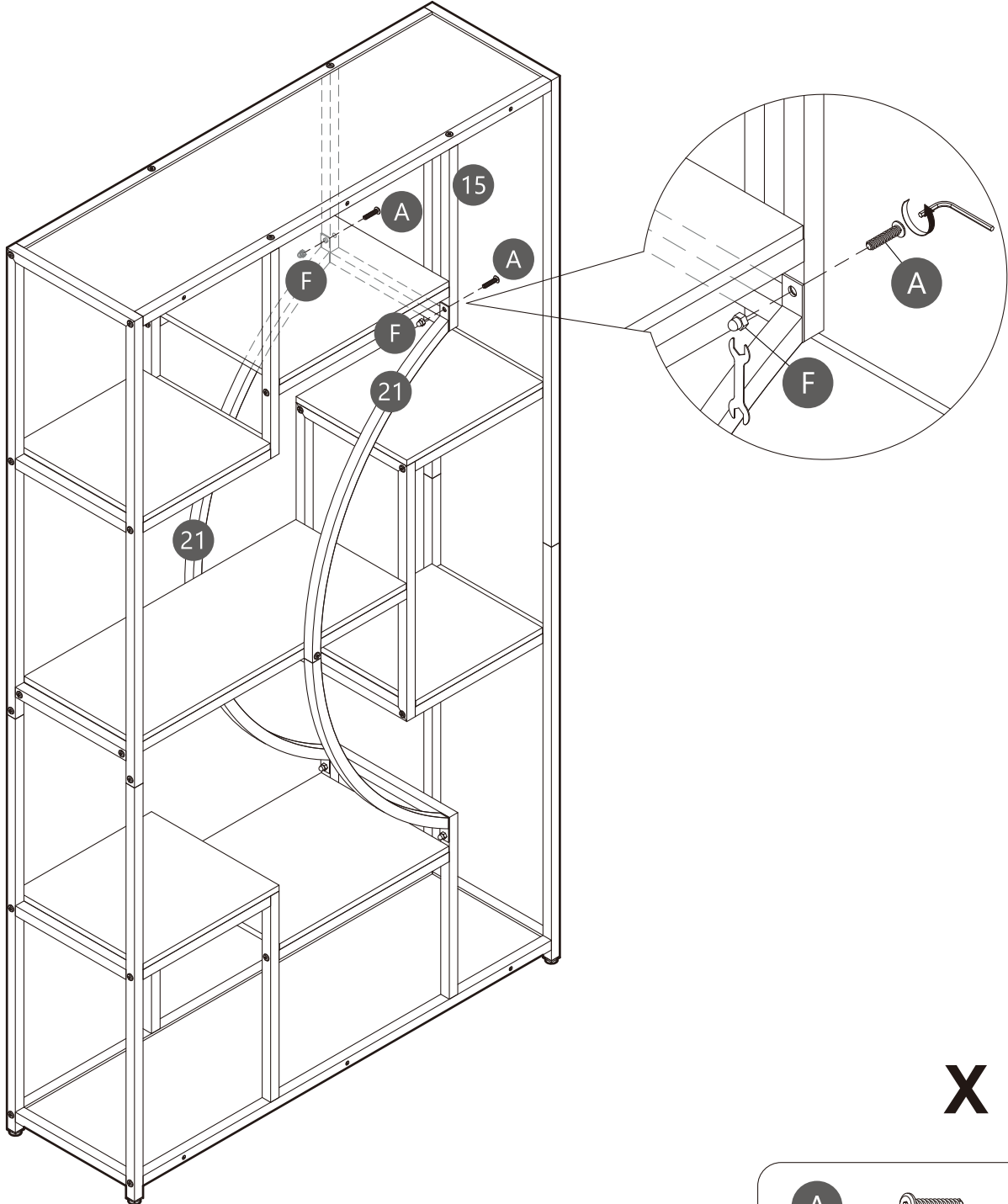
Screw (A) to lock (15)&(21) as below shown.

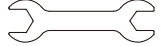

X 2

A		× 4
F		× 4
4#		× 1
		× 1

Step 25

Assemble the Anti-tipping.

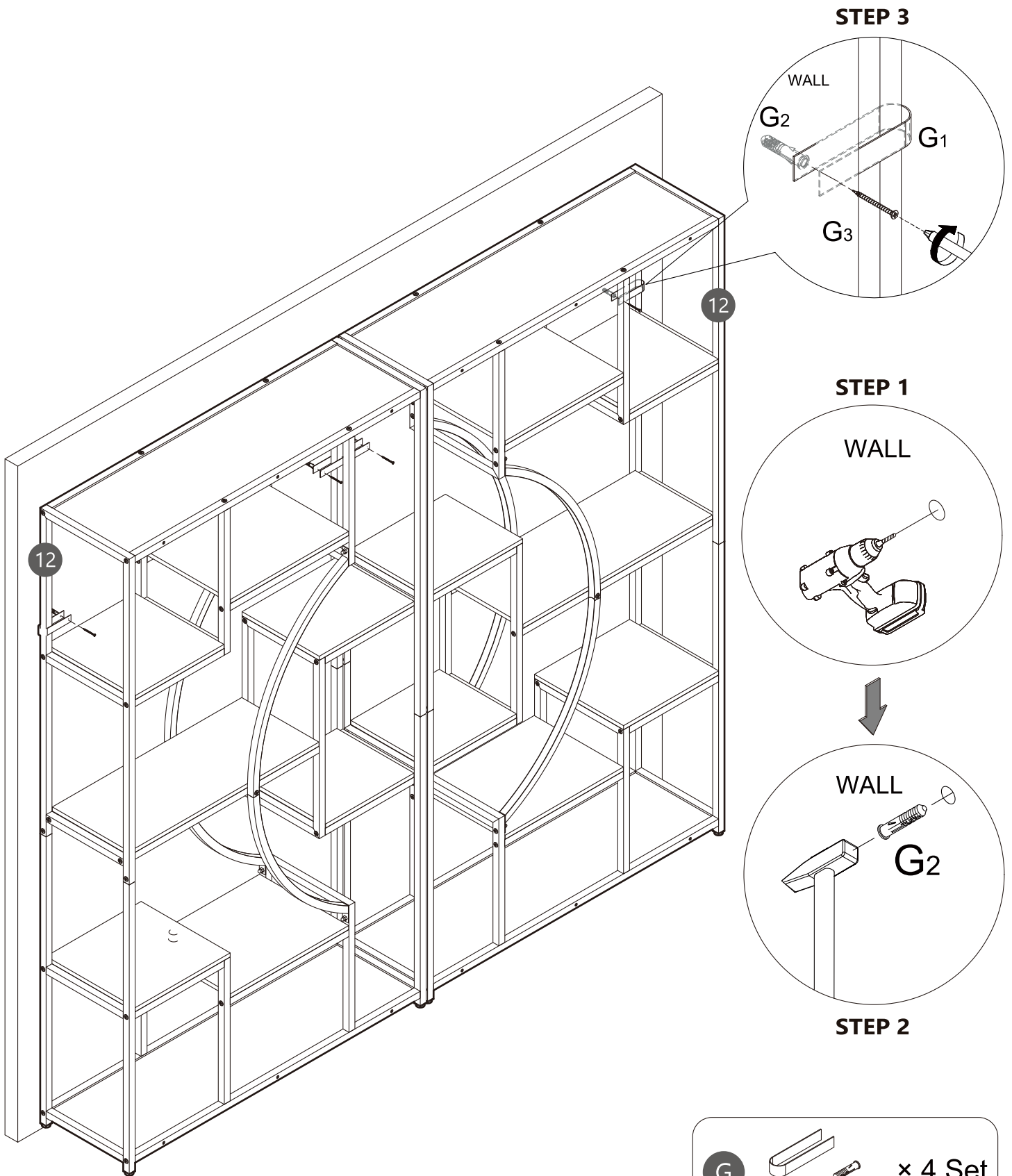

STEP 3

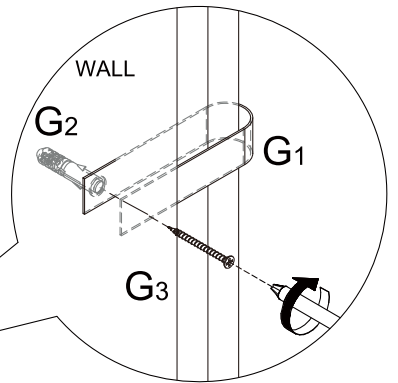

STEP 1

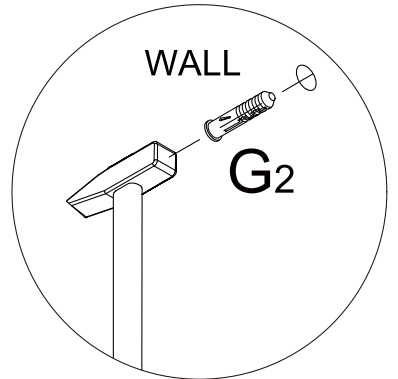
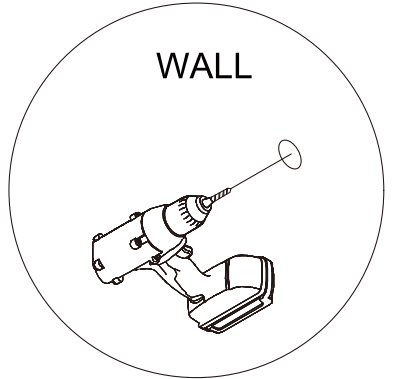

STEP 2

