

Assembly Instructions

Caution: You must read this before you proceed

Bench

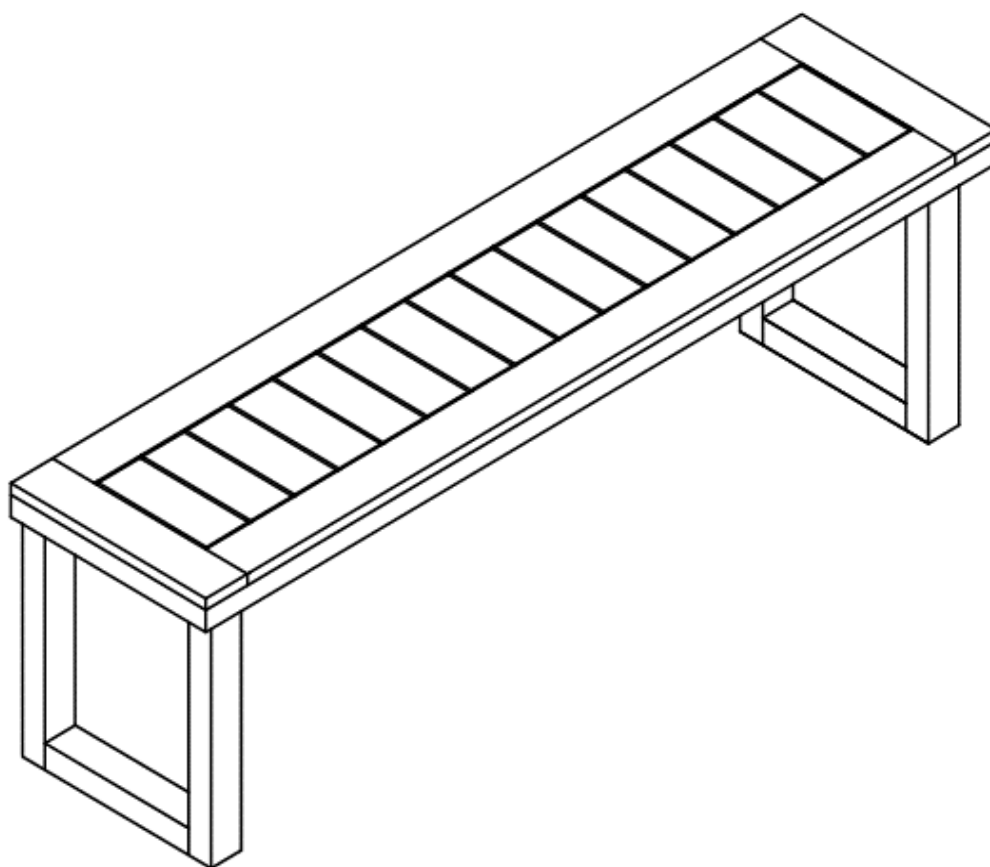

Caution: This Bench is NOT a TOY.

Keep your child / children at bay during the assembly process.

Whenever lifting or moving the Bench and to prevent damage to the Bench, two adults may be needed to execute these actions.

Parts List

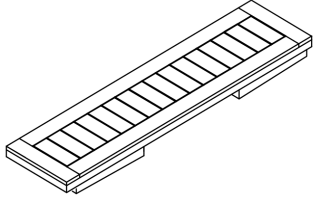
Label	Picture	Description	QTY
A		Bench Seat with Foldable Legs	1

Hardware

Label	Picture	Description	QTY
①		Bolt (M8x60mm)	5
②		Bolt (M8x45mm)	9
③		Allen Key	1

Assembly Preparation

Before Beginning Assembly:

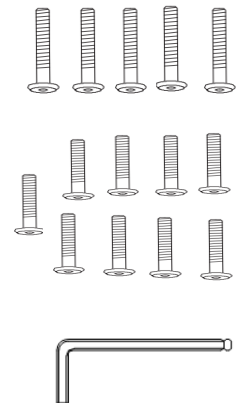
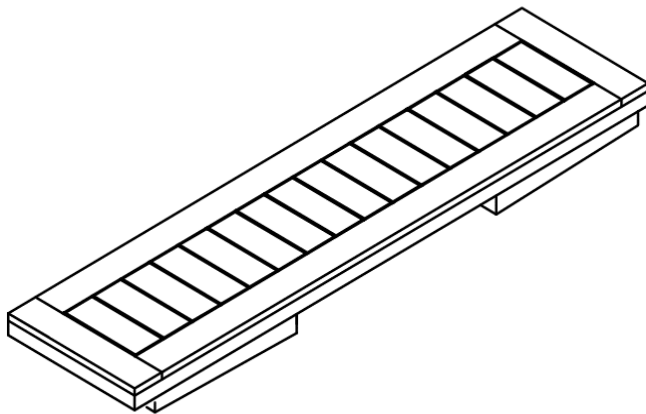

- Read instructions, cover to cover-



- Have 2 adults on hand for assembly-



- Do not assemble on flooring or carpet-



- Assemble on a clean non-marring surface (packing foam)-



- Save all packaging until finished-

Assembly Steps

Overview

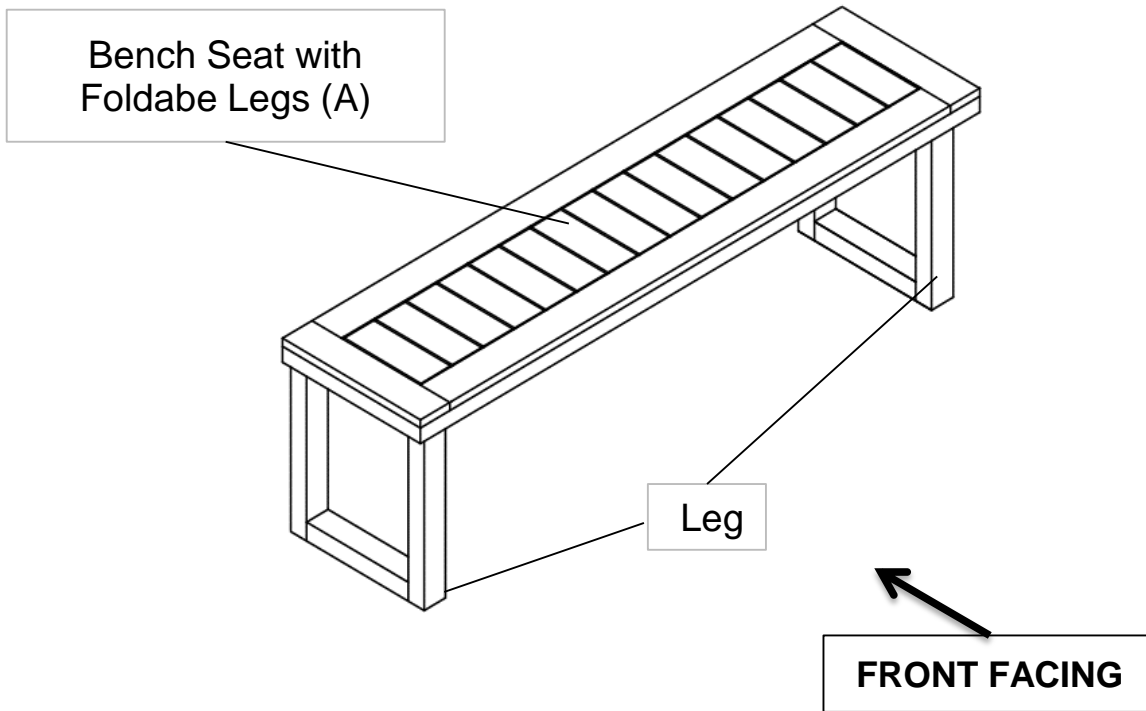

This Bench has multiple parts and may require up to 30 minutes to assemble. To give you an overview of the Bench parts, the above picture is to help you put the various parts into perspective. Please read through the instructions below to familiarise yourself with the parts and steps before assembly.

Step 1

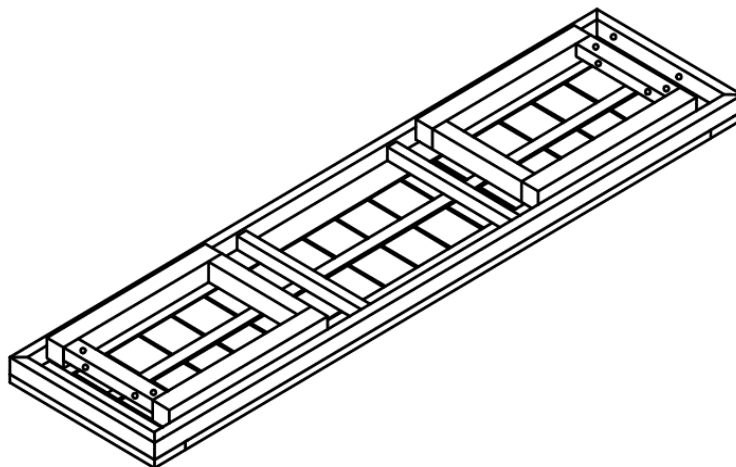

Unpack and place all parts on a clean, non-marring surface.

Step 2

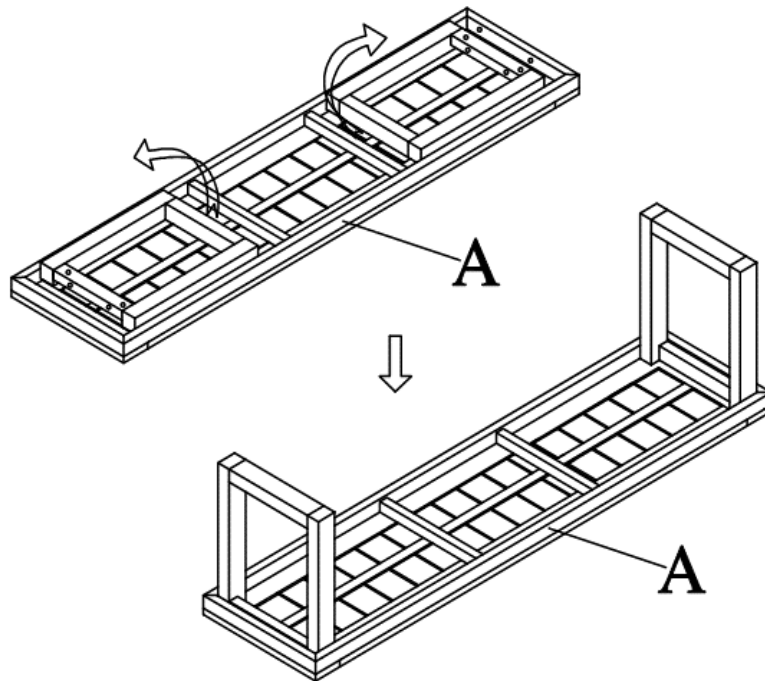

Place the Bench Seat with Foldable Legs(A) facedown, onto a clean, non-marring surface.

Fold out the Legs until the braces are flush with the base of the Bench Seat with Foldable Legs(A), as shown in the above picture.

Step 3

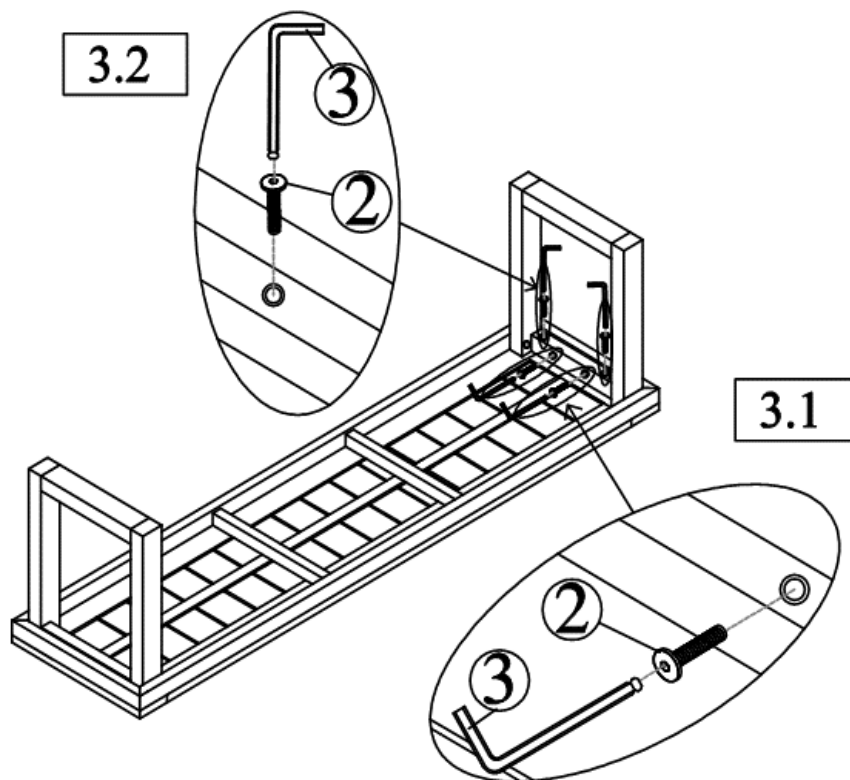

3.1) Secure Legs using Bolts(②) with Allen Key(③) as pictured above.

3.2) Secure Legs using Bolts(②) with Allen Key(③) as shown above.

Do not fully tighten the Bolts.

Step 4

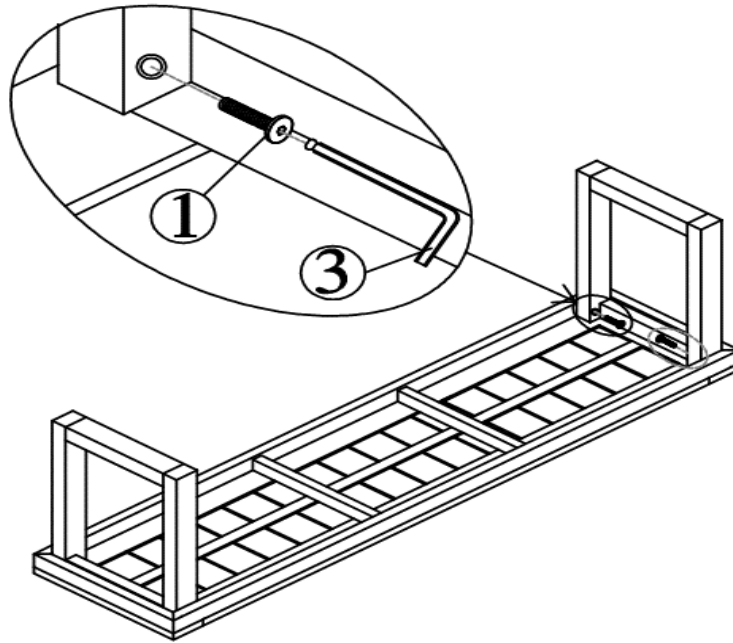

Secure Legs using Bolts(①) with Allen Key(③) as pictured above.
Do not fully tighten the Bolts.

Step 5

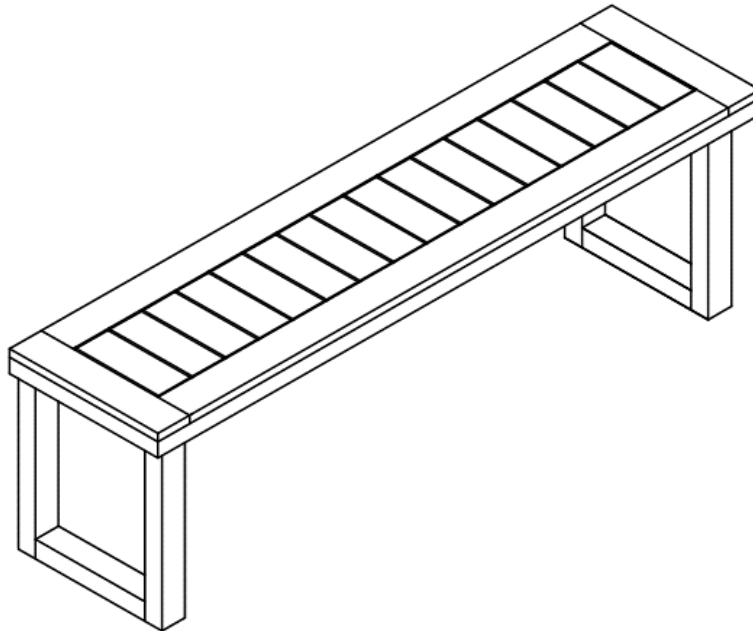

Stand the Bench up, with assistance from your adult partner.
Exert pressure floorwards, onto the Bench with both your hands.
This pressure will help the Legs and Bench Seat reach full alignment status.
Check for wobbles on a LEVEL surface.
If no wobbles are found proceed to tighten the Bolts in a sequential manner, until evenly secured.

When tightening the Bolts tighten sequentially.



















Do not tighten any Bolt fully and then move on towards the next one.

If there are still wobbles, loosen the Bolts and excute the same above process.

Your Bench is ready for use.

This Bench can only be used on the flat, level surface.

Care & Maintenance

-   ● Do not put hot items directly on furniture surface
 -   ● Do not clean furniture with harsh cleansers or polish.
 -   ● To obtain the longest lifespan of your outdoor products, minimizing exposure to direct sunlight is recommended.
 -   ● Children should not climb or jump on the furniture.
 -   ● Do not write on furniture without a padded barrier to protect the surface.
 -   ● To obtain the longest lifespan of your outdoor products, avoid extended and lengthy exposure to rain, snow, and direct sunshine. Whenever possible cover the product and /or place under patio or awnings.
 -   ● Not for commercial use. For residential use only .
 -   ● Stains may be removed with mild soap solution and damp cloth.
-
-   ● Dust and pick-up spills using a clean, non-colored, lint-free cloth .